



AquaMetrix AM-FCL Free Chlorine Sensor



Installation and Operation Guide

1. Introduction	3
2. Specifications	3
3. Principle of Operation	3
3.1. Free Chlorine	3
3.2. Probe Operation	5
4. Installation	5
4.1. Sensor Preparation	5
4.2. Flow Cell	6
4.3. Flow Meter	7
4.4. Installing the AM-FCL Probe	8
4.5. Electrical Connections	8
5. Sensor Maintenance	9
5.1. Cleaning the cathode	9
6. Calibration	10
6.1. Span/Slope Calibration	10
7. Maintenance	11
7.1. Sensor Storage	11
7.2. Membrane Cap Replacement	11
8. Troubleshooting	11
9. Appendix	12
9.1. Dimensions	12
9.2. Order Information	12
9.3. Warranty and Customer Support	13

1. Introduction

The AM-FCL is a compact, rugged free chlorine sensor that is primarily targeted toward clean water applications. The AM-FCL outputs a 4-20 mA signal and can be connected directly to a PLC or the AquaMetrix 2300. However it is typically bought as a replacement probe that is part of a chlorine analyzer system. Such a system consists of a flow cell and analyzer. The flow cell insures a constant pressure against the membrane and the analyzer combines the probe reading and the pH into a free chlorine signal.

2. Specifications

Wetted Materials	PVC
Membrane Material	PVDF
O-Ring Material	Viton
Anode	Silver-Silver Chloride
Cathode	Gold
Cable	2-conductor shielded, 10 ft. (3 m)
Measurement Range	AM-FCL-2: 0 to 2 ppm AM-FCL-5: 0 to 5 ppm AM-FCL-10: 0 to 10 ppm
Temperature Compensation	Pt 100 RTD
Operating Temperature Range	0 to 45 °C
Maximum Pressure	14.7 psi at 40 °C
Flow Range	0.2 to 0.6 gpm (0.8 to 2.4 l/min)
Supply Voltage	12-24 VDC, 250 mA
Cross Sensitivity	Monochloramine, chlorine dioxide, ozone, bromine, iodine
Chemical Compatibility	Up to 50% ethanol/water or glycerol/water.
Dimensions	8.2" length x 1" diameter
Mounting	Optional constant pressure flow cell recommended
Environmental Ratings	NEMA 4X, IP67, CE certified

3. Principle of Operation

3.1. Free Chlorine

Free chlorine is a frequently misunderstood term. When chlorine (Cl_2) dissolves in water it creates hypochlorous acid (HOCl):

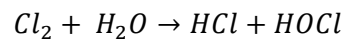

Eq. 3-1

HOCl is a very strong oxidizing agent and disinfectant. However it partitions into H^+ and hypochlorite (OCl^-) to some degree:

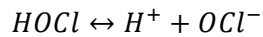

Eq. 3-2

The degree to which this dissociation takes place depends on pH. When the pH is low, i.e. the concentration of H^+ ions is high, then the equilibrium in this relationship is driven to the left and HOCl is the predominant species. Conversely, under basic conditions the equilibrium shifts to the right and OCl^- is the predominant species. **Error! Reference source not found.** shows the ratio of the one species to another. At pH values less than 7 the mixture is mostly HOCl. At pH values greater than 8.5 the mixture is mostly OCl^- .

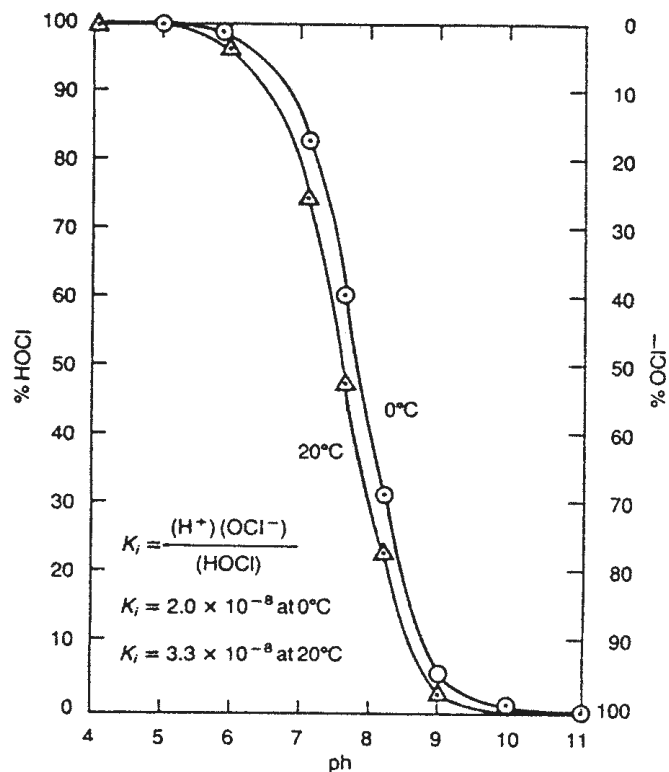

Figure 1 - Concentration of HOCl vs. pH. As the pH increases, more HOCl converts to OCl^- .

Free chlorine is defined as the sum of HOCl and OCl^- . Since most regulations refer to free chlorine concentrations any measuring device must measure this sum of species. Colorimetric test kits, based on the reaction of DPD with chlorine, measure the total free chlorine concentration. However amperometric chlorine sensors only measure the concentration of HOCl. Therefore, the output of the free chlorine sensor must be corrected to give the sum of HOCl and OCl^- using the relationship displayed in Figure 1.

Most regulations call for free chlorine without specification of the percentage of HOCl. Unfortunately, specifying the free chlorine concentration without specifying the pH does not give an unambiguous measure of the oxidation or disinfection power of the chlorine solution. A 4 ppm free chlorine

solution at pH 6 will have about 100 times the disinfection power of a 4 ppm free chlorine solution at pH 9. Therefore it's vital that all free chlorine measurements are accompanied by pH measurements.

3.2. Probe Operation

The AM-FCL is a two-electrode, amperometric sensor. At the cathode free chlorine, HOCl, reduces to OH⁻ and Cl⁻ according to the following reaction:



Reduction takes place on the surface of an inert gold electrode. The reduction reaction must be balanced by a corresponding oxidation reaction at the anode. That reaction is:

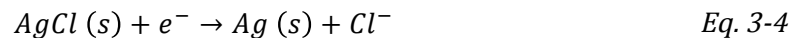

The PVDF membrane is highly selective to free chlorine so the current resulting from its oxidation is proportional to the rate at which HOCl permeates the membrane. The reduction of HOCl as expressed in Eq. 3-3 depletes the supply of free chlorine in the vicinity of the membrane. Therefore a constant flow of at least 0.2 gpm is required to prevent the sensor signal from artificially dropping. The rate at which HOCl is consumed is also proportional to the pressure on the membrane. For this reason it is important to keep the pressure the same during operation as during calibration. A flow cell, in which the probe is suspended, and a variable area flow meter enable both the flow and pressure on the sensor to remain constant (providing that the flow to the meter is above the minimum).

The typical chlorine analyzer calculates the free chlorine concentration from the pH of the sample and the relationship shown in Figure 1. If the output is fed into a PLC then the latter does this same calculation.

4. Installation

WARNING: If this equipment is used in a manner not specified by the manufacturer as per the User's Manual Water Analytics shall not be liable for any problems that arise and the warranty shall be null and void.

4.1. Sensor Preparation

The AM-FCL comes packaged with:

1. 2 membrane cap assemblies (AM-FCL-MC)
2. 2 bottles of replacement electrolyte (AM-FC-RE)
3. 3 sheets of cathode polishing paper
4. 1 pressure relief band
5. 1 syringe for filling electrolyte

To prepare the probe for operation follow these steps:

1. The probe is also packaged with a protective sleeve to protect the cathode and must be removed.
2. Fill the syringe with electrolyte and dispense it into the chamber surrounding the cathode. Let the solution start to overflow to insure the chamber is completely filled.

3. Screw on the membrane cap assembly. Excess fluid will drain from the pressure relief hole.

Note: For storage of the probe when not in use, remove the membrane cap, empty the electrolyte and store the cap in tap water.

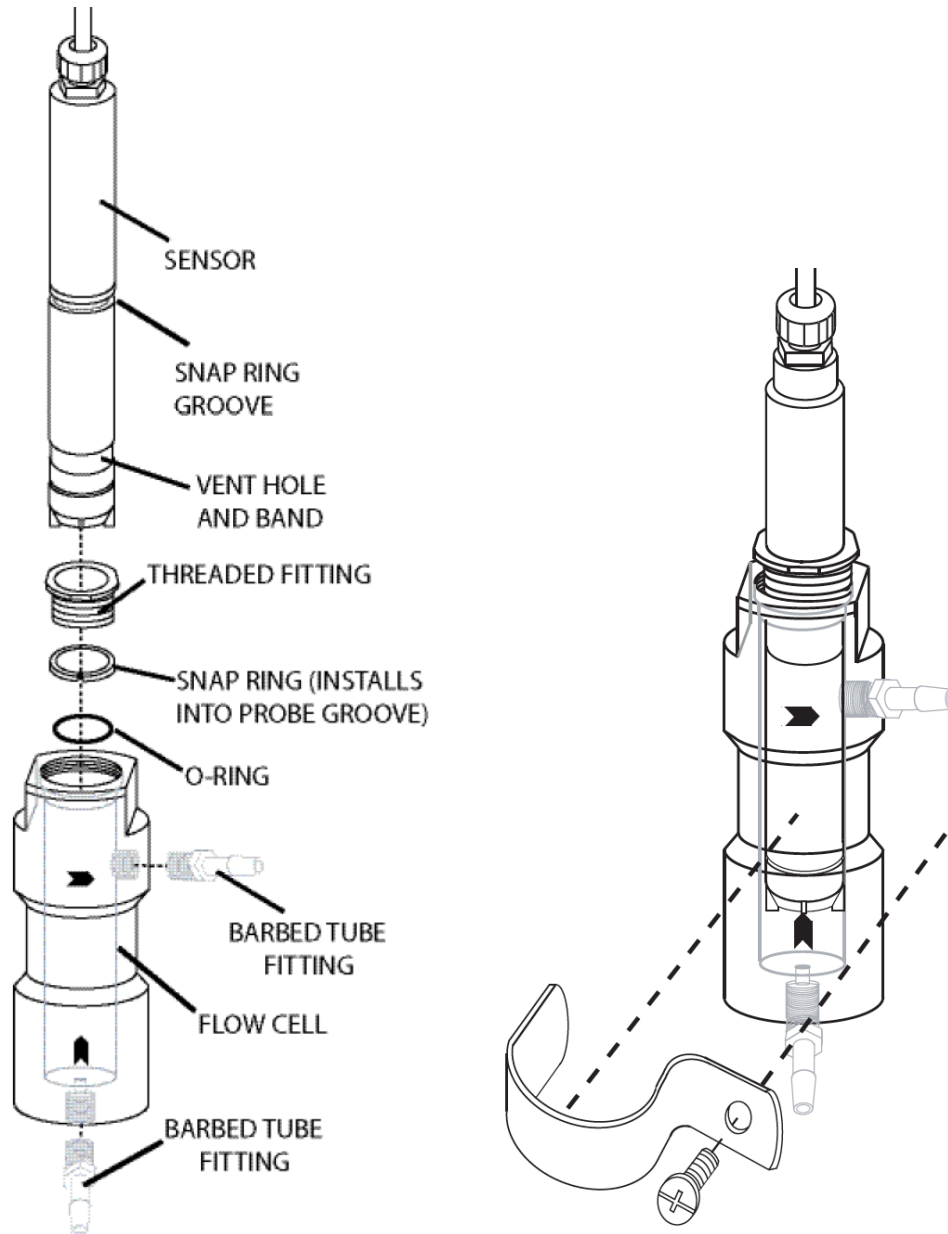

Figure 2 - Left: Exploded view of AM-FCL probe and flow cell (AM-FCL-FC). Right: Flow cell (AM-FCL) and mounting bracket.

4.2. Flow Cell

A flow cell, custom machined for the AM-FCL, is available from AquaMetrix (AM-FCL-FC).

A small pump (not available from Water Analytics) is necessary to provide flow to the sensor. Most aquarium supply retailers sell inexpensive low flow pumps (e.g. Tom Aquatics Aqua-Lifter dosing pump). You will need ¼" tubing to connect the pump to the flow cell and, if used, the flow meter.

As shown in **Error! Reference source not found.** water flows into the bottom of the flow cell and exits from the side.

If using a flow meter connect the pump to the flow meter.

1. Connect ¼" tubing from the flow meter to the flow cell. The AM-FCL-FC comes with two ¼" NPT-barb fittings. If they are not attached screw the fittings into the cell. If any leakage occurs then use Teflon tape around the male fitting.
2. The flow cell must be mounted on a vertical surface. The cell must be oriented within 45° of vertical. Typically that is a panel cut to size. Drill a 3/8" hole in the panel and mount the cell with the clamp.

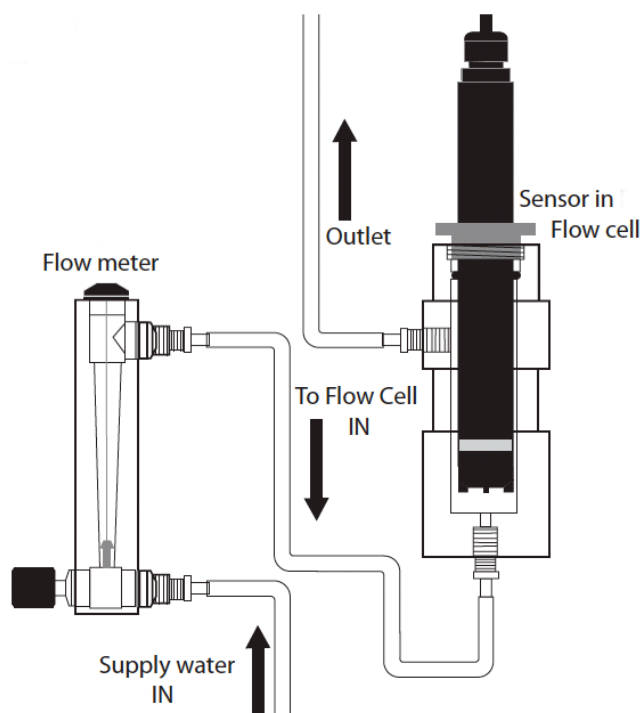

Figure 3 - Schematic of probe, flow cell and flow meter

4.3. Flow Meter

A variable area flow meter is highly recommended. It precedes the flow cell. You can purchase one from AquaMetrix—part number AM-FCL-FM—or purchase it from one of several laboratory supply companies.

4.4. Installing the AM-FCL Probe

Figure 3 shows the complete assembly of probe, flow cell and flow meter, including the direction of water flow.

1. Install the threaded fitting onto the probe body.
2. Insert the snap-ring into the groove on the sensor body.
3. Slide the O-ring onto the probe body until it reaches the bottom of the threaded fitting.
4. Insert the probe assembly into the flow cell as shown in Figure 3.
5. Turn on the flow of water. Ensure that the water flow is between 0.2 and 0.6 gpm.

4.5. Electrical Connections

The AM-FCL is a 2-wire sensor that connects to a PLC or the AquaMetrix 2300. The supply voltage to the Sensor must be 12-24 V DC with minimum of 250 mA. Maximum load is 1 Watt. The sensor has 2 wires, red (+), black (-).

Figure 4 shows the electrical connections to the AquaMetrix 2300. The same wiring diagram holds for a PLC. The Sensor will require several minutes to stabilize after power is supplied to it.

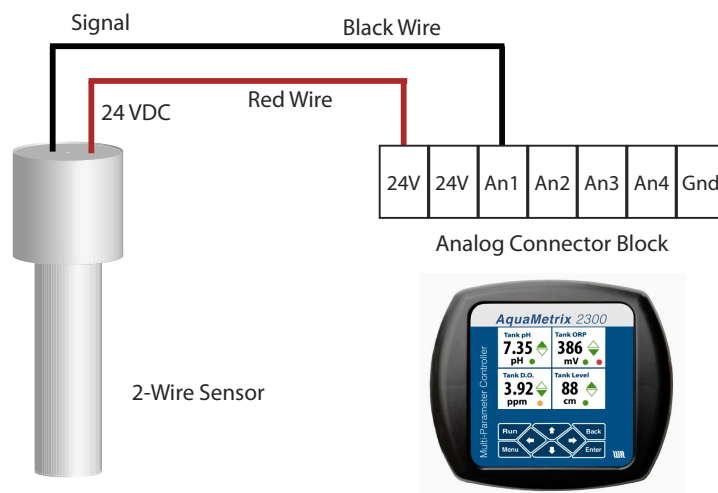

Figure 4- Electrical connections between AM-FCL and the AquaMetrix 2300. The connections will be the same for other controllers or PLC's.

5. Sensor Maintenance

5.1. Cleaning the cathode

If replacing the electrolyte and membrane still do not restore the probe to normal operation then the gold cathode may have a film of oxidation film. To remove the film requires a fine abrasive paper (included). Make sure you wear rubber gloves and protective eyewear (1).

1. Hold or clamp the sensor vertically and upside down so that the electrode is pointing up.
2. Unscrew the bottom cap (2) and dry the cathode with a dry cloth (3). Be careful not to rub the gold surface as it is easily scratched.
3. Using the supplied abrasive paper, shiny side up, and rub it over the cathode using a circular motion move the paper slightly as you rub the cathode to continuously expose new abrasive material (3). It does not take a lot of force, but continue to rub in a circular pattern for about a count of 60 (4). Note the surface is domed and needs to stay this way – do not put a flat on the cathode.
4. Check that the oxidation has been removed. The oxide layer is not easy to see, but the gold cathode should look brighter and shinier than before. If necessary, repeat the operation using the abrasive paper (5).
5. Soak a Q-tip with fresh electrolyte and lightly wipe the electrode surface to clean off debris. Use only light pressure as the gold surface can be easily damaged (6).
6. Top off the electrolyte with the syringe and needle so as to flush out any contaminants that may have dropped into the holes and the adjacent surface. If the cap is new and in good shape, add a few drops of electrolyte to the inside of the membrane pocket, then screw it slowly back on to the sensor (7). Catch any electrolyte that runs from under the cap with a towel.
7. Install sensor back into flow cell and start flow. Apply power to sensor for at least 4 hours before calibrating.

Only use the abrasive paper. Other types can damage the gold electrode.

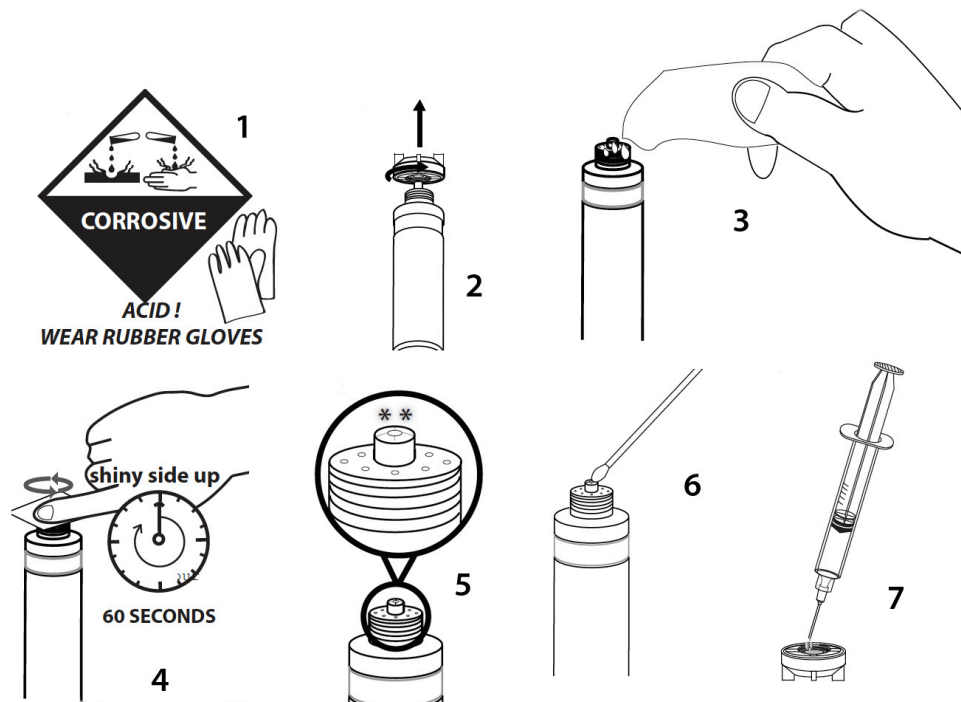

Figure 5 - Steps in replacing electrolyte and cleaning cathode. See sequence above for description of steps indicated by numbers.

6. Calibration

The AM-FCL is factory calibrated with its 4-20mA signal output corresponding to its specific range: 0-2, 0-5 OR 0-10ppm. Any span/range calibration can be done at your PLC, AquaMetrix 2300 or other 4-20mA input device. Fine span calibration can be done at the sensor if required. This is normally done at the factory. Call Water Analytics before attempting this adjustment. The zero-point calibration is not necessary since the zero setting is very stable. Check calibration about once per week. There is no need to calibrate if it has not changed much. This is useful in tracking sensor failures as well.

6.1. Span/Slope Calibration

1. Determine the free chlorine concentration using a diethyl-p-phenylenediamine (DPD) colorimetric test kit. You can purchase inexpensive kits at your local pool store. You can also purchase a more sophisticated colorimetric analyzer.
2. Measure the current output from the sensor for that chlorine concentration. For greatest accuracy ensure that the concentration is near the maximum of the probe range (2, 5 or 10 ppm). Make sure that the calibration flow rate matches the flow rate when measuring sample since probe output is flow rate dependent. Make sure pH is within 4.0 to 9 range.
3. If using a PLC: Adjust the span/slope
4. Repeat this slope calibration one day after sensor is initially installed.
5. Repeat the calibration monthly.

7. Maintenance

7.1. Sensor Storage

Store sensor at a temperature between 5 and 50 °C and maximum relative humidity of 95%.

1. For short-term storage (one week or less): Store in the flow cell with water to prevent the probe from drying out.
2. For Intermediate-term (one week to one month): Store in cap, bottle, or beaker with water to keep membrane wet.
3. For long-term (one month or longer): Remove the membrane cap and store cap completely immersed in tap water. Remove the fill solution and pour down drain.

Note: Electrolyte shelf life is one year from date of manufacture.

7.2. Membrane Cap Replacement

If membrane replacement is required, a new cap with preinstalled membrane must be used. One cap and refill solution is shipped with each sensor. Additional caps are ordered as AM-FCL-MC, and refill solution as AM-FCL-RE.

To change the membrane cap:

1. Turn the sensor upside down with cap facing upward.
2. Unscrew the cap to remove it.
3. Using a syringe remove solution from the bottle of electrolyte.
4. Fill the sensor body with electrolyte using needle and bottle of refill solution. Fill the body with solution until the solution leaks out.
5. Screw on a new membrane cap.

8. Troubleshooting

The following three scenarios are the most commonly encountered problems.

*The sensor cannot be calibrated. Its output is **higher** than the range set by the DPD test.*

1. The probe is not sufficiently conditioned. Ensure that is powered and operating for at least a half-hour.
2. The membrane is damaged and needs to be replaced. Follow directions in Section 7.2.
3. The DPD colorimetric kit has aged and needs to be replaced.
4. The operating temperature is higher than the calibration temperature.

*The sensor cannot be calibrated. Its output is **Lower** than the range set by the DPD test.*

1. The probe is not sufficiently conditioned. Ensure that is powered and operating for at least a half-hour.
2. The flow rate is too low. Ensure that it is at least 0.2 gpm.
3. There are air bubbles on the membrane. Increase flow (as above).
4. The membrane is coated with surfactants. Replace cap and eliminate source of surfactants (i.e. detergents).
5. The operating temperature is lower than the calibration temperature.
6. The cathode is coated. Polish the cathode is described in Section 5.1.

The sensor output is stuck at 4 mA.

1. There is no free chlorine present.
2. The probe is not sufficiently conditioned. Ensure that is powered and operating for at least a half-hour.
3. There is no electrolyte in the cap. Refill the electrolyte.
4. The sensor wiring connections are wrong. See Figure 4.

9. Appendix

9.1. Dimensions

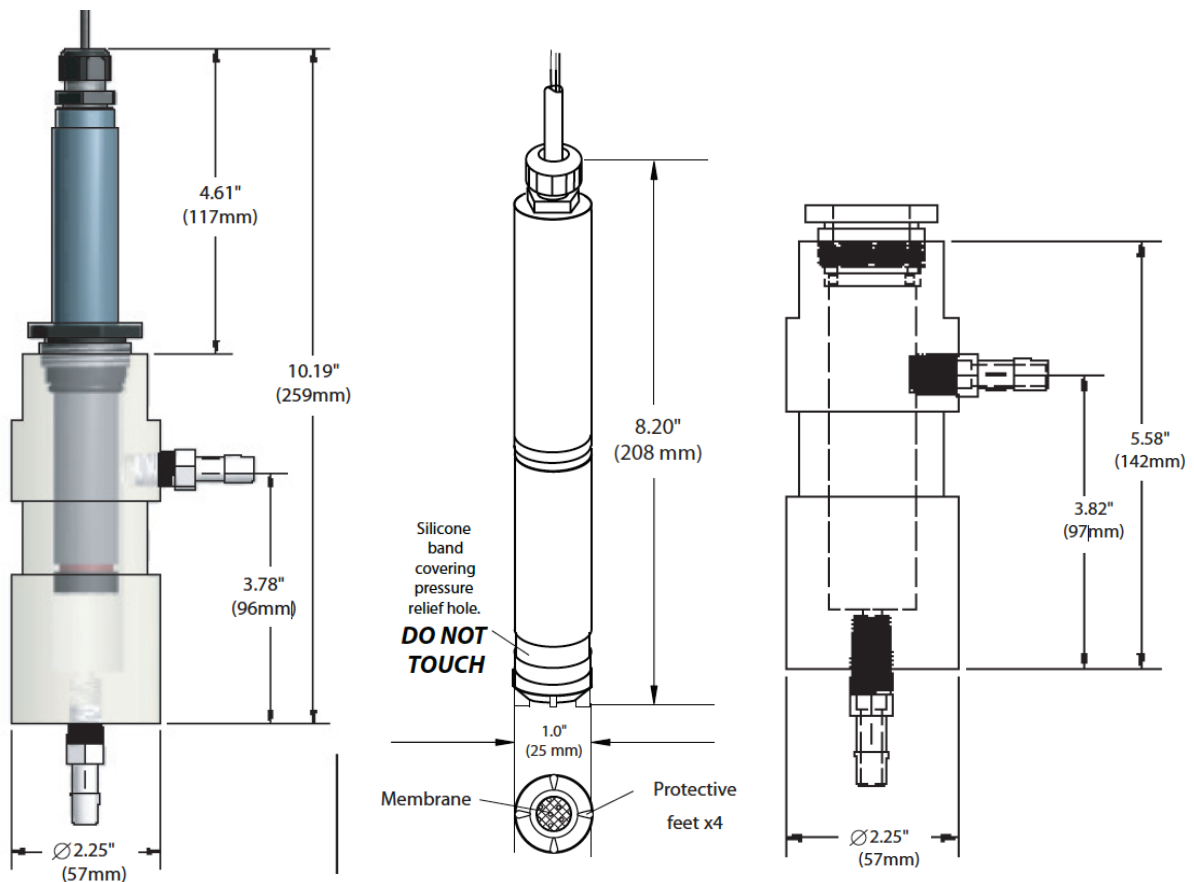

Figure 6. - Dimensions of probe and flow cell

9.2. Order Information

Part Number	Description
AM-FCL-02	0-2 ppm
AM-FCL-05	0-5 ppm
AM-FCL-10	0-10 ppm

AM-FCL-FC	Flow Cell
AM-FCL-FM	Variable Area Flow Meter
AM-FCL-RE	Electrolyte
AM-FCL-MC	Membrane Cap

9.3. Warranty and Customer Support

AquaMetrix will replace or repair this product if it fails due to defects in material or workmanship for a period of up to **one year from the date of shipment to the user**. A warranty claim will not be honored if defects are not reported within the warranty period, or if Water Analytics determines that defects or damages are due to normal wear, misapplication, lack of maintenance, abuse, improper installation, alteration, or abnormal conditions. Water Analytics' obligation under this warranty shall be limited to, at its option, replacement or repair of this product. The product must be returned to Water Analytics, freight prepaid, for examination. The product must be accompanied with an MSDS for all the process chemicals used, must be thoroughly cleaned and any process chemicals removed. Water Analytics' liability shall not exceed the cost of the product. Contact Water Analytics or your distributor to initiate warranty support.

Products may not be returned without authorization from Aquametrix.

For assistance please contact:

Water Analytics, Inc.
 100 School Street
 Andover, MA 01810
 978-749-9949 x207

support@wateranalytics.net

www.Aquamatrix.com or www.WaterAnalytics.net