



AquaMetric 2250 / 2250 TX
Multi-Parameter Controller / Transmitter



Installation and Operation Manual (rev.1.7)

Contents

1	Introduction.....	4
1.1	Third in a Long History of Controllers.....	4
1.2	Differences between the 2250 and 2250 TX.....	4
2	Specifications.....	5
3	Setup.....	6
3.1	AC Power Connections (2250 Controller only).....	6
3.2	Loop power connection (2250TX Transmitter only).....	7
3.3	Conduit Connection.....	8
3.4	Mounting.....	8
3.5	Connecting Probes.....	9
3.6	Analog (4-20 mA) Outputs.....	10
3.7	Wiring Relays – 2250 Only.....	10
4	Probe Setup.....	10
4.1	pH.....	11
4.2	ORP Probes.....	12
4.3	Conductivity Probes.....	12
4.3.1	Cell constant.....	12
4.3.2	Temperature Element.....	12
4.3.3	Temperature Unit.....	13
4.3.4	Conductivity Units.....	13
4.3.5	Temp Coefficient.....	13
4.3.6	Temp Compensation.....	14
4.4	Flow.....	14
4.4.1	Volume Units.....	14
4.4.2	Time Units.....	14
4.4.3	Totalizer Reset.....	15
5	Calibration.....	15
5.1	pH.....	15
5.1.1	About pH Calibration.....	15
5.1.2	2 points.....	16

5.1.3	3-Point Calibration.....	18
5.1.4	Temperature Calibration	18
5.2	ORP Calibration.....	19
5.3	Conductivity.....	19
5.3.1	Manual Calibration	20
5.3.2	Cell Constant.....	21
5.3.3	Temperature.....	21
5.4	Flow	21
6	Output (2250TX has only one 4-20mA output, as described in 6.2)	22
6.1	Relays.....	22
6.1.1	Rising Process	23
6.1.2	Falling Process	24
6.1.3	Cycle On/Off	24
6.1.4	Relay Off Delay	25
6.1.5	Overfeed Timer.....	25
6.1.6	Relay Override	26
6.1.7	Summary.....	26
6.2	4-20 mA Output – Channel 1	26
6.2.1	Channel 1 – [PV] – 4 mA	26
6.2.2	Channel 1 – [PV] – 20 mA	27
6.3	4-20 mA Output – Channel 2.....	28
6.4	4-20 mA Output for Proportional Control	28
6.5	PID Control.....	28
6.6	Manual Test.....	29
7	Diagnostics.....	30
7.1	Calibration Data.....	30
7.2	Sensor Output.....	30
7.3	Rest User Cal.....	31
7.4	About	31
8	Preferences.....	31
8.1	Auto Return	31
8.2	Damping.....	32
8.3	Backlight (2250 only)	32

1 Introduction

1.1 Third in a Long History of Controllers

The 2250 multi-parameter controller is the third generation controller built on the 30-year AquaMetrix legacy of building durable and easy-to-use controllers. Many of the 2200 controllers sold those three decades ago are still in use today in some of the most hostile environments found in industry. Orders continue to come in today for 2200 pH, ORP or conductivity models, five years after they entered end-of-life status.

In 2006 the 2200 series of controllers were rolled into one multi-parameter controller, the Shark, and a transmitter version, the Shark TX. One Shark can handle a pH, ORP, conductivity or flow sensor with just a menu change. The Shark continued the 2200 tradition of providing near bulletproof performance in demanding industrial environments.

Water Analytics built on three decades of design experience and conversations with its customers to bring to market the 2250 controller and 2250TX transmitter. Some of the design improvements over the Shark include:

- A form factor that enables better wall mounting.
- Large LCD screen—backlit in the 2250 version.
- An intuitive menu structure, which means reading this manual should not be necessary.
- An advanced conductivity measurement design that results in a ten-fold improvement in accuracy at low and high conductivity values.
- The ability to calibrate conductivity solutions in TDS units (mg/l).
- Three-point calibration for pH to give more accurate pH values over a wide pH range.
- Multi-point (<16) calibration routine for conductivity to enable acid and base concentration measurements.
- PID control.
- Easy-to-use screw-free probe connector.

1.2 Differences between the 2250 and 2250 TX

The 2250 is an AC-powered controller consisting of three relays and two 4-20 mA outputs. The 2250 TX is a transmitter version. It is loop-powered and does not contain the power-relay circuit board. Because of power constraints the LCD is not backlit.

2 Specifications

Probe Parameters				
	pH	ORP	Conductivity	Flow
Probe	6-wire differential, combination	6-wire differential Combination	2-electrode. Cell constants: 0.01, 0.1, 1.0, 10 and 50	Pulse output: Paddle-wheel Magnetic Flow
Temperature Elements	100, 1000 Ω RTD 300, 3000 Ω NTC	100, 1000 Ω RTD 300, 3000 Ω NTC	100, 1000 Ω RTD 300, 3000 Ω NTC	n/a
Sensor Input	-600 to 600 mV	-1999 to 1999 mV	Cond: 0 to 9999 Ω Temp: 0 to 9999 Ω	0 to 2000 Hz
Measurement Range	0 – 14 pH -20 – 150 °C	-1999 to 1999 mV	0.055 to 500,000 μS/cm, depending on cell constant	0 to 9999 in units: l, cm ³ , ft ³ , m ³ sec, min, hr
Temperature Compensation	Automatic -20 to 150 °C	n/a	Automatic or Manual	n/a
Calibration Mode	pH: Automatic or Manual Temp: Manual	pH: Manual Temp: Manual	Cond: Manual, Cell const. input Temp: Manual	K-factor input
Outputs				
Analog	2250: 2 x 4-20 mA, optically isolated 1-Process 2-Temperature or Process Scalable Max load: 800 Ω PID		2250TX: 4-20 mA – Process Optically isolated Scalable Max load: 800 Ω PID	
Relays	2250: 3 independent relays: 10A @ 120/240 VAC or 8A @ 30 VDC (Resistive Load) 5A @ 120/240 VAC or 4A @ 30 VDC (Inductive load)		2250TX: None	
Relay Modes	2250: Rising/Falling, Cycle On/Off, Relay Delay, Overfeed Timer, Override		2250TX: n/a	
Ratings				
Ingress Protection	NEMA 4X			
Electrical	UL, cUL and CE compliant and pending			
Max. Power Input	2250: 0.2 A @ 115 VAC or 15 W		2250 TX: 20 mA @ 24 VDC	
Temperature	-20 to 70 °C			
Humidity	0 to 90% Relative Humidity, non-condensing			
Physical				
Mounting	Wall mount, panel mount with kit provided, pipe mount optional			
Dimensions	Front cover: 5.5"x5.5" (14 cm x 14 cm). Depth: 5" (13 cm)			
Power	2250: 120/240 VAC 60 or 50 Hz		2250TX: 16-32 VDC	
Weight	2 lbs			
Protection	NEMA 4X			

3 Setup

3.1 AC Power Connections (2250 Controller only)

Caution: This instrument uses 120 or 240 50/60Hz AC power. Opening the enclosure door exposes you to potentially hazardous line power voltage which may be present on the power and relay plugs. Always remove line power before working in this area. If the relay contacts are powered from a separate source from the line power, be sure to that power before proceeding. The flip out door contains only low voltage and is safe to handle. Figure 3-1 shows 2250 controller power board and describes all connectors on it.

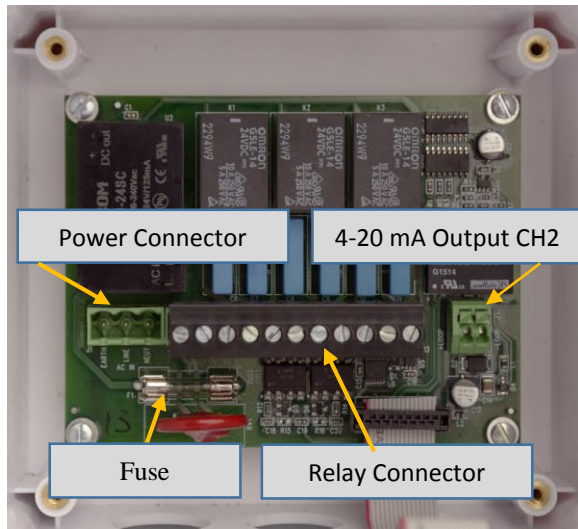

Figure 3-1 Power circuit board showing power and relay connectors. The second 4-20 mA output is also on the board.

To connect power to the 2250 controller, remove the 3-pin power terminal block (not shown in Figure 3-1) and connect the wiring as printed on the board and stated on Figure 3-2. There are no jumpers or switches to convert the controller between 120 VAC and 240 VAC – just power it up and the unit will recognize voltage automatically.

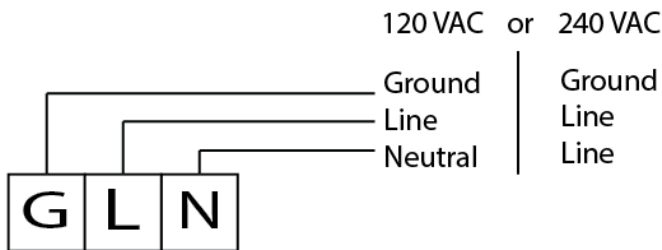

Figure 3-2 Power connection for 2250 Controller

3.2 Loop power connection (2250TX Transmitter only)

The 2250TX is a low power transmitter. Having low power consumption allows several connection options including loop powered and externally powered. Figure 3-3 below shows three most common options.

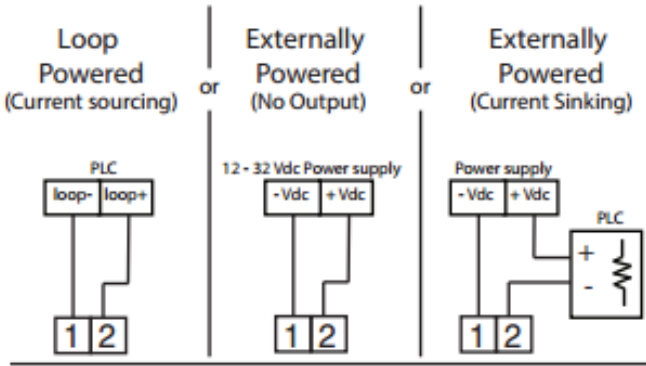

Figure 3-3 Most common 2250TX powering options

If the PLC or recorder has internal loop power, i.e. supply current (current sourcing devices) then one can use loop powered option. This is the simplest way to connect 2250TX transmitter and have 4-20 mA current feedback to PLC/recorder.

2250TX can also be powered directly by external power supply with voltage as low as 12VDC or as high as 32Vdc. Be aware that using that option only good for applications where measured value required to be displayed on the screen of the transmitter only. **4-20 mA output is disabled.**

Lastly, 2250TX can be used with PLC and data loggers without internal loop power, i.e. which do not supply current (current sinking devices). To do this just connect power supply in series, as shown on the right of Figure 3-3. The required power supply voltage will vary depending on resistor in PLC or recording device. Figure 3-4 will help to choose right power supply based on PLC loop resistance.

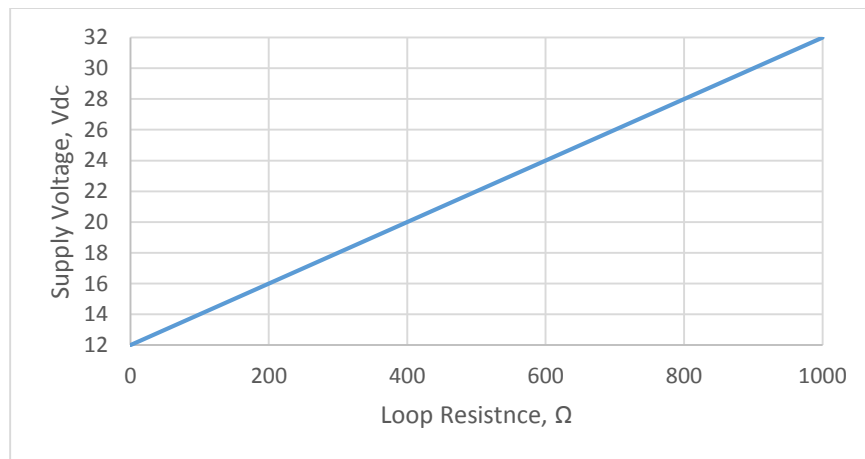

Figure 3-4 Required voltage for power supply for current sinking devices

3.3 Conduit Connection

The 2250 and 2250 TX has six 0.87" (22mm) conduit holes at the bottom of the enclosure. The unit is shipped with these holes plugged with liquid tight conduit seals. These must be left in unused holes to maintain the NEMA 4X integrity. Use approved conduit hubs to connect the conduit, connect these to the conduit before connecting the enclosure.

Wire specification: Size and fuse wire according to local electrical code. Maximum current not to exceed relay specifications when used to power auxiliary devices via internal connections.

3.4 Mounting

The 2250 can be mounted on a wall, panel or pipe. Figure 3-5 shows these three options. All hardware for wall and panel mounting is included. For pipe or DIN rail (2250TX only) mountings there are optional kits available for sale.

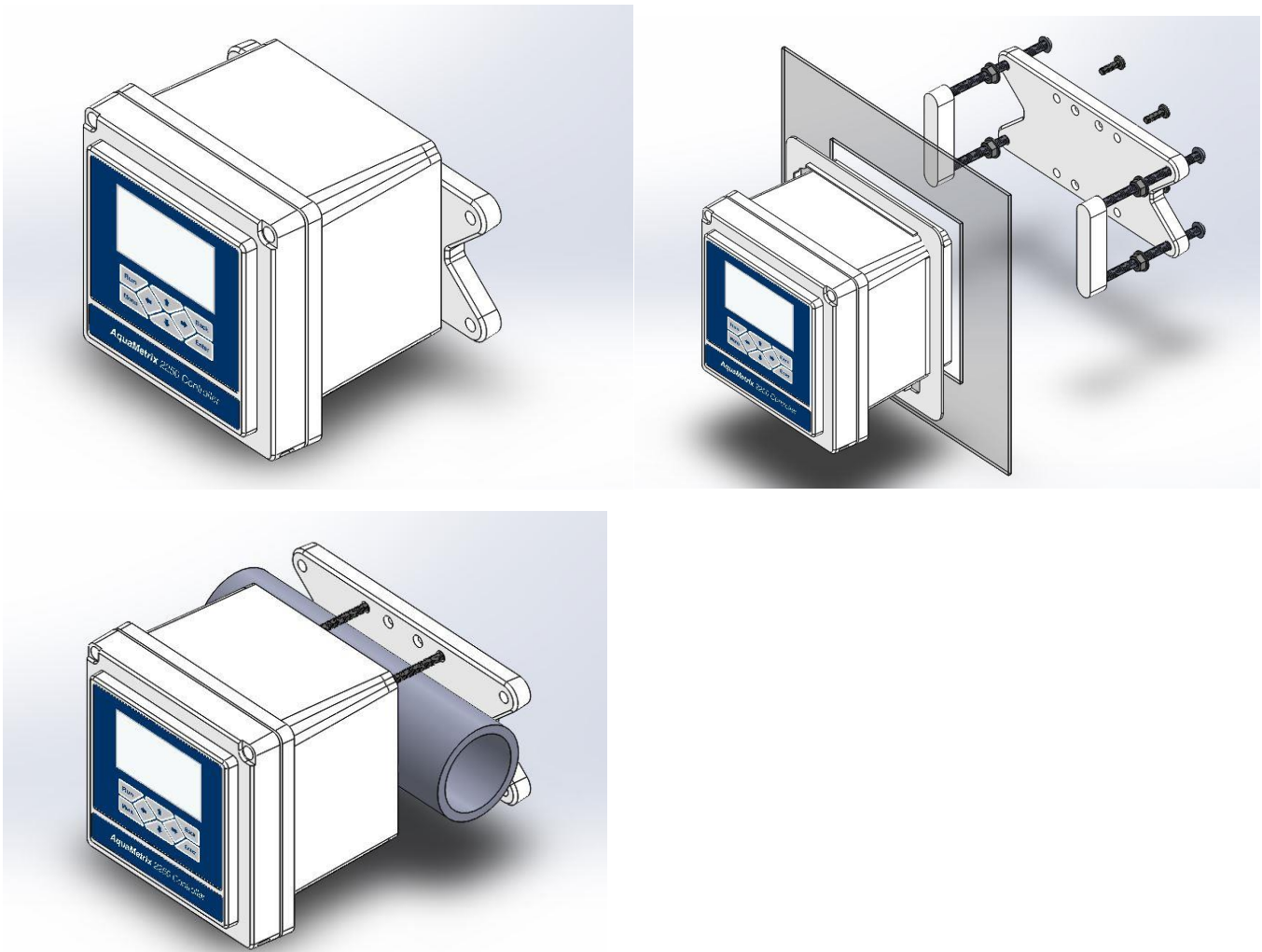

Figure 3-5 - Three mounting options: wall, panel and pipe. Hardware for wall and panel mounting are all included. Pipe mounting fasteners are available upon request.

3.5 Connecting Probes

As shown in Figure 3-6 the cover of the 2250 swings open to reveal a connector block for connecting probes. A label inside the controller identifies the terminals so reference to this manual is unnecessary. Note that connector 1 and 2 are for the 4-20 mA output.

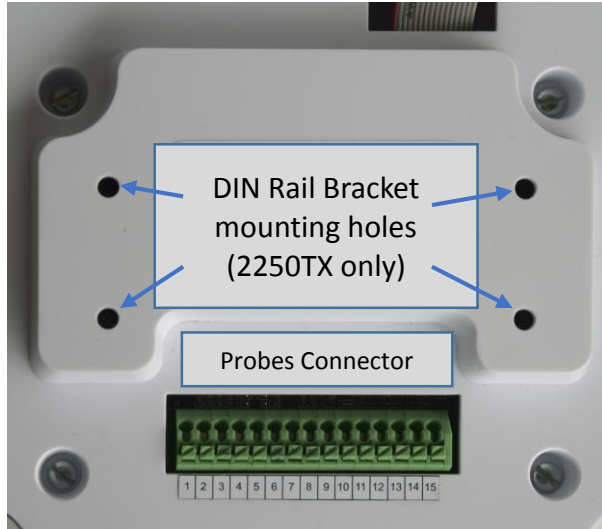

Figure 3-6 - This view of the inside of the front cover shows the connector for the probes and mounting holes for DIN rail brackets.

The table below shows the connections for all five types of probes to the connector block. The color colored cells refer to the colors of the wires of AquaMetrix probes. Other manufacturer probes may use different colors. Color coding of differential probes match that of Hach/GLI analog probes.

Probe connection	1	2	3	4	5	6	7	8	9	10	11	12	13	14	15
pH/ORP Differential			Power -	Shield		Process +	Ground	Process -	Temp						
pH/ORP Combination (Short 7-8)						Coax Center	Jumper Temp Ground	Coax Shield	Temp Signal						
Conductivity							Temp Ground		Temp Signal	Process Ground	Process Signal				
Flow Meter			<i>*Only for externally powered sensors</i>										Signal +	Signal - / Shield	
			-3V	GND	+3V										

3.6 Analog (4-20 mA) Outputs

The 2250TX contains one 4-20 mA output. It is the two terminals 1 and 2 on the probe connector as mentioned in the last section. The 2250 has a second 4-20 mA output that can be configured for either the process value or temperature. It is located on the power supply board, which is shown in Figure 3-1. The 2 push-pin connector is on the lower right of the board, next to relay connector.

3.7 Wiring Relays – 2250 Only

There 2250 contains three dry contact relays rated 10A @ 120/240 VAC or 8A @ 30 VDC for resistive load and 5A @ 120/240 VAC or 4A @30 VDC for inductive load. In spite of their ratings we strongly advise to consider using them as switches, e.g. DC low power relays, to activate a second set of AC-powered relays separate from the controller.

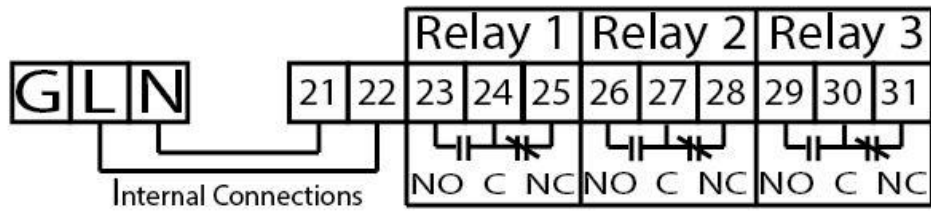

Figure 3-7 - Wiring connections to the three relays. All relays are powered by internal jumpers between the ac power and terminals 21 and 22.

4 Probe Setup

When powering up the 2250 the first screen presents options for configuring sensors. When setting up the 2250 for the first time or when setting up the 2250 for a sensor type that is different from an existing one, then choose the **Setup** menu, then **Probe Selection**.



Figure 4-1 Initial start-up screen

The top-level menu allows the user to configure the 2250 for a pH, ORP, conductivity or flow sensor. Note that flow sensors are those that output a square wave pulse whose frequency is proportional to the flow.

The Setup option in the top-level menu allows you to completely configure a new probe or change an existing one.

4.1 pH

1. Scroll down the top level menu to elect **Setup** and press the **Enter** key.
2. Press **Probe Selection** to choose the probe type, pH.
3. Press **pH**. It is the first item on the list of probes so it is already selected.
4. This selection automatically brings up the next menu for defining the configuration of the pH probe.
5. Type sets the probe as a **Combination** or **Differential** probe. The 2250 will accept just about any type of either. Entering a probe as the wrong type will simply result in an artificial offset at pH 7 and may not cause any noticeable reading or error. Combination probes may consist of only two wires for the process and reference or four wires, which includes two leads for the temperature element. Differential probes always have five or six wires—the 6th wire being an optional shield conductor. After selecting the type the next menu automatically appears to show the configuration of the probe
6. With the exception of the two-wire combination probe, the type of temperature element must be selected. Select **Temp Element** to bring up the choices of temperature elements: Ω

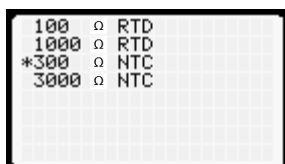

The default setting is the 300 Ohm RTD as that is the temperature element standard on AquaMetrix differential probes. Please note that RTD's show a positive correlation with temperature while NTC (Negative Temperature Coefficient) display a negative one.

7. Select the preferred units of temperature (Temp Unit):



The Kelvin scale is an absolute one, meaning that 0 K is absolute zero. It equals degrees Celsius plus 273.15.

4.2 ORP Probes

The setup for ORP probes is identical to that of pH probes. The output ORP probes that have temperature elements, which includes all differential probes, is NOT temperature compensated. The temperature is an independent reading.

4.3 Conductivity Probes

1. Scroll down the top level menu to elect **Setup** and press the **Enter** key.
2. Press **Probe Selection** to choose the probe type, **Conductivity**.

```
Cell Constant
Temp Element
Temp Unit
Conduct Units
Temp Coefficient
Temp Compensation
```

4.3.1 Cell constant

You must know the correct cell constant. It is typically written on a label attached to the conductivity probe.

```
0.01 (0.2-10 uS/cm)
0.1 (10-500 uS/cm)
*1 (0.1-5 mS/cm)
10 (1-50 mS/cm)
50 (5-250 mS/cm)
100 (10-500 mS/cm)
```

For convenience the approximate conductivity range for each cell constant is displayed alongside the constant in the list of available constants. However, choosing the cell constant on the basis of the desired range will give you incorrect readings if the correct probe for that range was not properly chosen. For instance you may have a probe with a cell constant of 10—corresponding to a range of 1 to 50 mS/cm—yet you wish to measure conductivity values on the order of 0.1 mS/cm (or 100 μ S/cm). If you choose a cell constant of 1 to encompass this range the 2250 will display values that are 10 times the correct values. **Choose the cell constant for the probe, not the cell constant that has the desired conductivity range.**

4.3.2 Temperature Element

Conductivity readings are strongly influenced by temperature so nearly all conductivity probes have temperature elements. The same choices for temperature element for pH and ORP are present for conductivity. The default element for AquaMetrix AM series probes is the 1000 Ω RTD so that option is pre-selected.

```
100  RTD
*1000  RTD
300  NTC
3000  NTC
```

4.3.3 Temperature Unit

As in pH and ORP probes the choices for the temperature units are Celsius, Fahrenheit and Kelvin.



4.3.4 Conductivity Units

Conductivity values span a range of a million to one so one unit for representing values is impractical. The choices are:

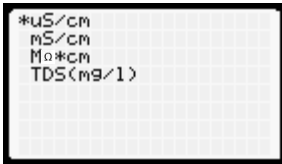

- **μS/cm.** For clean, tap, surface or ground water this unit is the most common. RODI water typically has conductivity of 1 μS/cm or less. Tap water is around 300 μS/cm.
- **mS/cm.** Salt solutions, acid and bases use the higher range. 1 mS/cm = 1000 μS/cm. Confusion between the two is responsible for nearly all problems selecting conductivity sensors and setting up the correct range.
- **MΩ-cm.** For very pure water many workers prefer to report resistivity units in place of conductivity units. One is the inverse of the other, e.g. 1 μS/cm = 1 MΩ-cm. Ultrapure water has a resistivity of 18.8 MΩ-cm. (Its finite resistance is the result of H⁺ and OH⁻ ions.)
- **TDS (mg/l).** The correlation between total dissolved solids (TDS) and conductivity varies with every sample of water. In order to display conductivity in terms of TDS units one must choose a conversion factor. Selecting this option brings up a display where you select the conversion of TDS units to μS/cm units.



The default value is 1 μS/cm = 0.65 mg/l. This is the value that most inexpensive pen-type TDS probes assume. The only way to assign a custom conversion factor is to measure the TDS value by evaporating the water from a sample and weighing the leftover solids.

4.3.5 Temp Coefficient.

Over a limited temperature range the variation of conductivity with temperature is linear. Conductivity values are always reported at the 25 °C. Therefore, the correction between the conductivity at any given temperature (T) and the conductivity 25 °C at is:

$$\sigma(T) = \sigma(25^{\circ}C)[1 + \alpha (T - 25^{\circ}C)]$$

T is the temperature of the sample and α is the temperature coefficient.

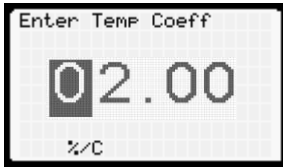

The default value for α is 2.00 per degree C or 1.10 per degree F. You can change it to any value needed.

4.3.6 Temp Compensation.

For most applications temperature compensation should always be **On**.



However for diagnostic purposes and some isolated cases where you need to know the actual conductivity (and not the value at 25°C). For these isolated cases turn compensation **Off**.

4.4 Flow

Any flow sensor that outputs a pulse will work with the 2250. The 2250 measures instantaneous flow and totalized flow. The latter is a running total of the volume and is equal to the flow integrated over time. Flow has units of volume/time so there are two units to specify:

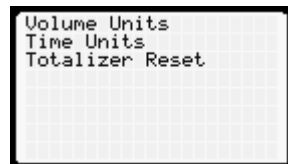

4.4.1 Volume Units.

Choices are gallons, ft³, cm³ and liters.

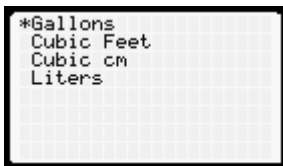

4.4.2 Time Units.

Choices are milliseconds, seconds, minutes and hours.

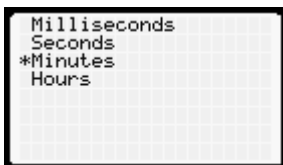

4.4.3 Totalizer Reset.

This function resets the totalized volume to zero.

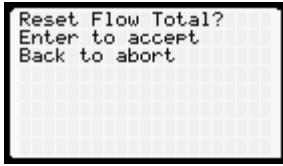

Described above is a reset using software.

There is also an option to reset flow totalizer using hardware: just short pins 14 and 15 of probe connector.

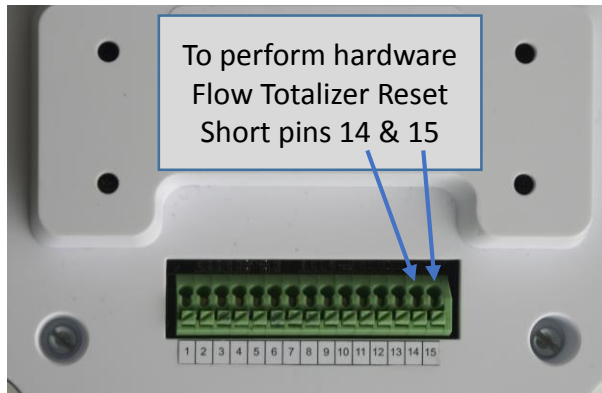

Figure 4-2 Flow Totalizer Reset using probe connector

This hardware reset can be used in conjunction with external button or switch to perform quick manual totalizer reset. For daily total a mechanical or electrical timer can be used to short pins 14 and 15 in a set period of time.

5 Calibration

The 2250 only presents menu choices appropriate for the probe chosen. If the wrong menu choices for calibration appear then go back to the Setup menu and select the correct probe.

5.1 pH

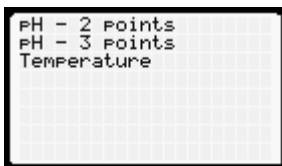

5.1.1 About pH Calibration

Most pH analyzers allow the user to calibrate a probe with only two points. Nearly all pH calibration is done using two of three standard calibration solutions: pH 4, 7 and 10. For two-point calibration use the two standards that are closest to your expected process values. For example, if your process is mostly acidic (< pH 7) then calibrate using standards pH 4 and pH 7.

For measurements that span either side of neutral (i.e. pH 7) the 2250 offers the option of three-point calibration. Three-point calibration yields higher accuracy than using only two points, pH 4 and 10. An algorithm calculates the best fit slope through the three points using linear least squares fitting and is superior to algorithms that just interpolate between the two neighboring points.

A pH probe that operates according to theory outputs 59.16 mV at 25°C for every change in pH. The actual change in output for a real probe is likely to be different and is the **slope** for that probe. An ideal probe in pH 7 solution (at 25°C) outputs 0 volts. The actual output is likely to be different and is the **offset**. The slope yields the **efficiency** of the probe. A probe that outputs 59.16 mV at 25°C is 100% efficient. If the probe outputs, say, 57.34 mV then the efficiency is 96.9% efficient.

When a probe leaves the AquaMetrix factory it is tested three times to insure that its efficiency is at least 90%. As probes age their efficiency decreases. Note that a probe with low efficiency will still be accurate but it will not be precise, i.e. its reading will have a large uncertainty. We recommend replacing a probe when its efficiency drops below 80%. (Before discarding a probe with low efficiency make sure it is clean. A probe whose process electrode is fouled will show a low efficiency but can be cleaned and restored to working at high efficiency.)

A probe that leaves our factory also has an offset that is within 59 mV, i.e. 1 pH unit, of 0. A changing offset usually indicates that the reference solution is contaminated.

5.1.2 2 points.

As stated above, use the two calibration standards that encompass the pH range of your process.

There is a choice between [auto](#) and [manual](#) calibration.

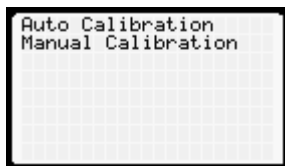

5.1.2.1 Auto Calibration

In auto calibration the 2250 reads the probe output when it is in a buffer and judges whether the buffer is pH 4, 7 or 10. Ideal voltages for these buffers are 177, 0 and -177 mV. If the output of the probe is within 59.16 mV (1 pH unit) from any of these values auto calibration assumes it “knows” the calibration standard in which the probe is immersed. If the output is greater than 59.16 mV auto calibration will fail.



There are several reasons why this can happen:

1. The offset from the expected reading at pH 4, 7 or 10 (i.e. 177, 0 and -177 mV) is greater than 59 mV.
2. You are using a non-standard buffer.

3. The buffer has aged and is no longer at its nominal pH value.

To initiate auto calibration:

1. Select [Auto Calibration](#)
2. Follow the directions on the next screen and immerse the probe in the first calibration standard. A typical probe takes about 1 minute to calibrate. It helps to swirl the probe around in the solution. After a minute or longer press the [Enter](#) key as instructed. (If you press the [Enter](#) key too soon the analyzer will accept an inaccurate probe reading and the efficiency is likely to be lower than it should.)



3. The screen will display [Calibrating](#) for a few seconds as it reads the probe output and stores the probe value. The next screen will appear and will direct you to immerse the probe in the second calibration standard. (*Always rinse the probe in clean tap water when changing buffers.*) Again, wait at least one minute before pressing [Enter](#) to record the probe output value of the second calibration solution.



4. The screen will again display [Calibrating](#) for a few seconds and will display the results of the calibration. An example is:

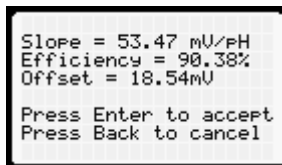

As the screen instructions state, press [Enter](#) to accept the calibration or [Back](#) to repeat it. Pressing [Menu](#) brings you back to the top menu.

5.1.2.2 Manual Calibration

As explained above manual calibration can be used if the probe has a very large offset, has low efficiency or is being calibrated with non-standard buffer solutions.

1. Select [Manual Calibration](#)
2. Place the probe in the first buffer. As opposed to auto calibration, it is okay to press [Enter](#) without waiting for the probe output to settle down. The next screen will display the current output reading of the probe. The pH is calculated from the mV reading based on the operation of a perfect probe at 25 °C, i.e. pH 7= 0 mV and the voltage increment is 59.16 mV/pH.

3. When the reading settles down press Enter. The next screen allows you to change the value of the displayed pH value to correspond to the actual pH of the calibration solution. Use the **up** and **down** arrow buttons to change the value and the **left / right** arrows button to change the cursor position. Press the **Enter** key to lock in the correct value.

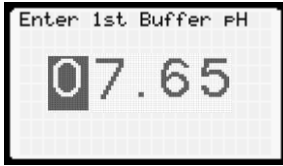

4. The results of the calibration, identical to the one shown for auto calibration, will display.
5. Place the probe in the second buffer. Again, there is no need to wait for the probe reading to settle down prior to pressing **Enter**.
6. When the reading settles down press Enter. Change the pH reading to the pH of the calibration standard.

5.1.3 3-Point Calibration

The instructions for 3-point calibration are the same as for 2-point calibration with the obvious exception that three standards are used instead of two.

5.1.4 Temperature Calibration

Since all pH readings are temperature compensated, an accurate pH reading depends on an accurate temperature.

1. Select **Temp Calibration**.

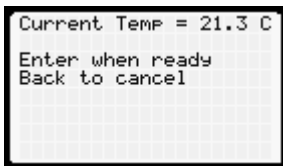

2. The screen displays the current temperature reading. Make sure the temperature reading has settled down. Keep in mind that most temperature elements in pH probes are encapsulated inside the probe, which results in a temperature lag of several minutes for the element to equilibrate with the temperature of the solution.
3. Temperature calibration is similar to manual pH calibration. When the temperature reading settles down press **Enter**. The next screen allows you to change the temperature reading to the actual temperature. Press **Enter** when done or **Menu** to go back to the top menu.

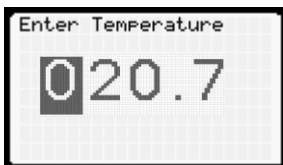

5.2 ORP Calibration

ORP is a unique water quality parameter. For all other parameters a voltage, current or other electrical change corresponds to a value of the parameter in a manner that calibration determines. For instance, a pH probe generates a voltage that maps to a pH value in the manner described above. The ORP parameter is the actual voltage of the probe. No translation to a dependent parameter takes place. An ORP analyzer is just a voltmeter and no calibration is needed.

However, all voltmeters need to be calibrated. The only practical way of doing so for an ORP analyzer is to measure the offset of the voltmeter. This is called a **standardization**. ORP calibration is therefore not a calibration at all but a standardization. *Nevertheless, this manual follows the loose practice of using the term "calibration" instead of "standardization."*

The process of standardization involves only one calibration standard. One immerses the ORP probe in a calibration standard and adjusts the reading of the analyzer until it matches the actual value of the solution.

There are no standard calibration solutions for ORP although Zobell's (XXX mV) and Light's (XXX mV) solutions are the most common. AquaMetrix makes its own versions of these two solutions that are nominally 200 and 600 mV. ORP solutions are not buffered which means that their ORP values are not as stable as pH buffered standards are. Each calibration solution AquaMetrix carries an ORP value that may vary within 20 mV of the nominal 200 or 600 mV value. Furthermore, these values will change so the chemicals in the solutions slowly oxidize, so ORP solutions should be replaced at least every 6 months.

For reasons just stated, ORP calibration is a manual, one-point procedure.

1. Select ORP Calibration.
2. Place the probe in calibration standard and press **Enter**. As in all manual calibrations there is no need to wait prior to pressing **Enter**.
3. Observe the probe output reading and, when it has settled down, press **Enter**.
4. Adjust the value displayed in the next screen until it matches that of the calibration standard. Note that ORP standards can be negative so be careful to set the correct +/- sign.

5.3 Conductivity

As with ORP calibration there are no recognized standard calibration standards so there is no auto calibration option. Also as with ORP, conductivity calibration standards are not buffered and can change. Stability of the conductivity standard is only a problem for standards of very low conductivity, where introduction of impurities in the solution can induce large changes in conductivity. At conductivity standards below 5 $\mu\text{S}/\text{cm}$ just carbon dioxide in the air can increase the actual conductivity.

In those cases where a conductivity standard is not available one may enter the cell constant of the probe as an approximate calibration. Obviously the calibration using the known cell constant is only as good as the cell constant is known. Usage of the probe can cause scaling or fouling of the electrode which will result in a reduced cell constant. Therefore, calibration using real a real conductivity standard is always preferred.

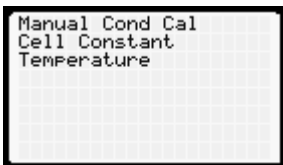

Most conductivity analyzers employ a calibration routine that uses only one calibration standard. This is actually a 2-point calibration routine inasmuch as the other point is assumed to be zero, i.e. that the conductivity for a zero conductivity sample is zero. The 2250 allows as many as 16 points. Though one point is sufficient for most applications the ability to calibrate over several points allows one to use conductivity measurements to determine acid and base concentrations. As the figure below shows conductivity as a function of acid/base concentration is very non-linear and, therefore, several points are needed to construct the curved relationship.

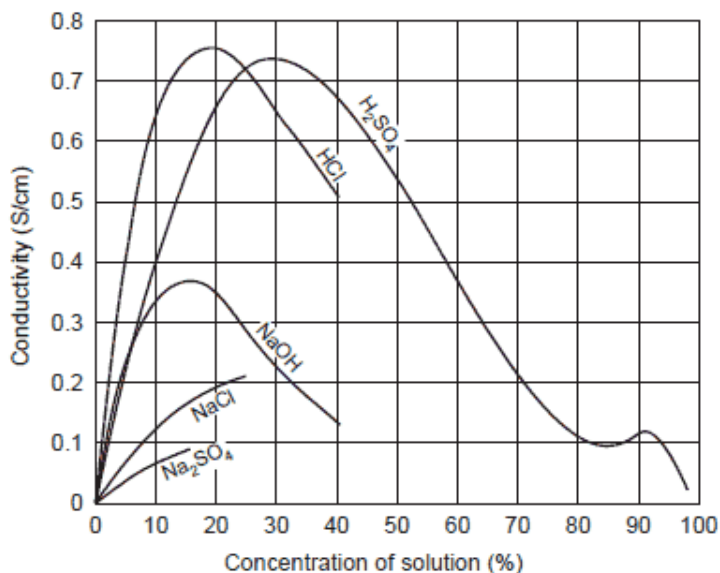
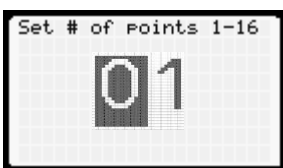

Figure 5-1 Relationship between Concentration of Solution and Conductivity (at 18° C)

5.3.1 Manual Calibration

The procedure for manual conductivity calibration is nearly the same as that for manual pH and ORP calibration. The only exception is that user can calibrate up to 16 points.

1. Select **Manual Calibration**.
2. Select the number of calibration standards to be used. In most cases choose 1. For greater accuracy choose 2 or 3. Only for measuring acid and base concentrations are more points needed. Press **Enter** to accept the number of points.



3. Immerse the probe in the first (or only) calibration standard. Press [Enter](#).
4. The display will show the current conductivity reading. Adjust the conductivity reading to correspond to the actual conductivity value of the standard.
5. Repeat for additional standards if there are any.
6. Press [Enter](#) to accept the calibration or [Back](#) to discard it.

5.3.2 Cell Constant

As explained above this procedure substitutes actual calibration with the input of the known cell constant. One might assume that this is the same cell constant value input during the Setup procedure. However, the actual cell constant of the probe is likely to be different from the nominal cell constant. For instance, the cell constant for a probe with nominal cell constant 1.0 cm^{-1} may actually be 1.05 cm^{-1} . If the actual cell constant is known then this calibration option allows one to input it.

1. Select [Cell Constant](#).
2. In the next screen enter the cell constant. Possible values are 0.01 to 999 cm^{-1} .
3. Press [Enter](#) when done.
4. Press [Enter](#) to accept or [Back](#) to cancel.

5.3.3 Temperature

Temperature calibration for a conductivity sensor follows the same procedure as for pH (Section 5.1.4).

5.4 Flow

There is no actual calibration procedure for a flow sensor. The K-factor supplied by the manufacturer sets the conversion between each pulse and the corresponding volume. The pulse frequency is proportional to the velocity of water flowing past the sensor. However, by incorporating the diameter of the pipe, the flow sensor manufacturer is able to convert the fluid velocity (e.g. cm/sec) into a flow rate (e.g. cm^3/sec).

For most applications the K-factor supplied by the manufacturer is sufficient to yield accuracy of better than 5%. For greater accuracy one can determine the actual K-factor by measuring the time it takes to fill a container with a known volume of water.

To input the K-factor:

1. Select [Manual](#). (It's the only choice but future firmware versions may allow the experimental determination of the K-factor though the container filling exercise mentioned above.)
2. Enter the K-factor. It's important that the flow units of the K-factor are the same as the units selected during setup. If they are different then go back to [Setup](#) and change the units. Alternatively, one can perform unit conversion arithmetic to insure that the K-factor entered has the units selected during setup.
3. Press [Enter](#) to escape this screen.
4. Press [Enter](#) to accept the K-factor or [Back](#) to cancel.

6 Output (2250TX has only one 4-20mA output, as described in 6.2)

The 2250 has three output modes:

1. Three dry contact relays
2. Two isolated 4-20 mA current outputs
3. PID control.

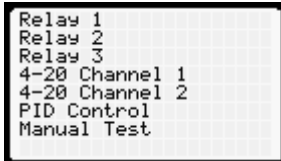

The 2250TX has one isolated 4-20 mA current output and PID control.

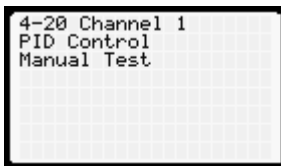

When the 2250 is used for process control then one to three of the relays are configured. When the 2250 is used in conjunction with PLC's or SCADA systems then the 4-20 mA outputs are configured. PID control is used for fine control of a process using the 4-20 mA output on the main board.

6.1 Relays

The 2250 is equipped with three relays rated for 10A @ 120/240 VAC or 8A @ 30 VDC (Resistive Load) 5A @ 120/240 VAC or 4A @30 VDC (Inductive load). For safety reasons we strongly recommend that relays in the 2250 control a low current circuit that closes a second relay for the pump or other process control device. Three relays give users the capability of controlling a falling process, rising process and a physical alarm.

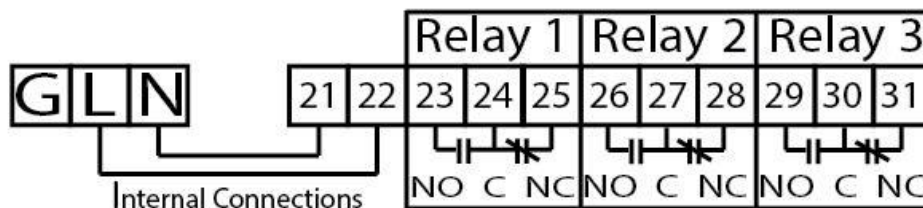
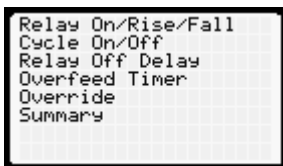

Figure 6-1 Wiring connections to the three relays

Note: All instructions assume a relay is wired as normally open (NO). If a relay is wired normally closed (NC) then activate or open should be reversed, i.e. deactivate or close.

It is important to distinguish between rising and falling processes. A rising process is one that triggers a relay (or alarm) when it rises above a setpoint. A falling process triggers a relay as it drops below a setpoint. For every alarm setpoint there is a second setpoint at which the relay deactivates. For instance, suppose you are controlling a process whose pH naturally rises. Let's suppose that, when your process reaches pH 9, a relay closes and starts a pump which dispenses acid to bring the pH back down. The pH value at which the relay opens again must be less than 9.0. If it is too close to 9.0, e.g. 8.9, you risk having the chemical dispenser cycle on and off too frequently. Even more problematic is that the relay changes state before the pH has a chance to equilibrate. The result is that the process is never stable and you waste more acid than necessary. For these reasons the relay deactivation must be sufficiently below the activation, e.g. pH 8.0 in this case.



The following description applies to all three relays.

6.1.1 Rising Process

1. Select **Rising**. A relay cannot be set for a rising process AND a falling process. If you previously set a relay for a falling process and you set it again for a rising process then the falling process automatically turns off.

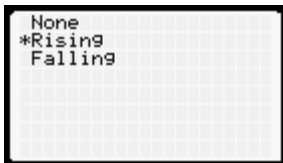

2. Enter the value of the process variable (e.g. pH) at which the relay turns on (i.e. the setpoint). Press **Enter** to accept this value.



3. Enter the value of the process variable at which the relay turns off. Press **Enter** to accept this value. As explained above the off value must be lower than the on value.



- If your off value is higher, then a warning message appears.



6.1.2 Falling Process

The same process holds for a falling process except that the on setpoint must be lower than the off setpoint.

6.1.3 Cycle On/Off

The cycle on/off parameter is very useful in preventing overshoot of a process controlling action—usually the dispensing of a chemical via a pump. If the response time of the process to the added chemical is slow compared to the rate at which the chemical is being added then the process variable will overshoot its target (as described in Section 6.1 for a rising process). Choosing set points for the activating and deactivating the relay is a first line defense against overshoot.

As a means to keep the two setpoints within a tight range, cycling the relay on and off is invaluable. As Figure 6-1 shows, the duty cycle is expressed as the duration over which the relay is activated divided by the total time of the complete on-off cycle. If the relay is on for 10 seconds and off for 30 seconds then the complete cycle is 40 seconds and the duty cycle is 25%. The slower the response time of the process to the added chemical (or other process control mechanism) the lower the duty cycle or time-on.

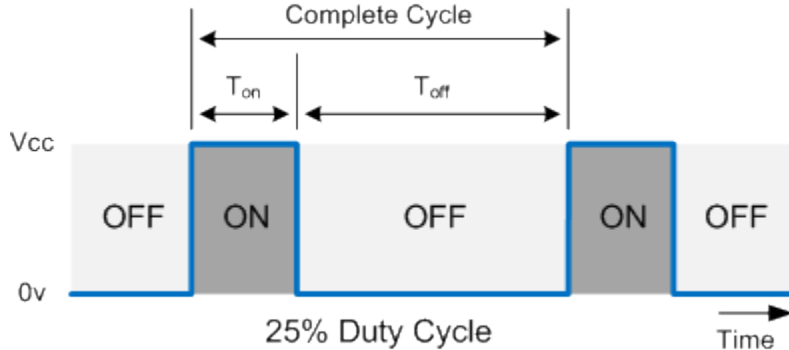
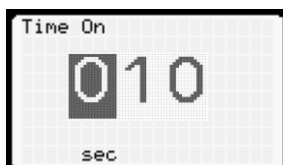
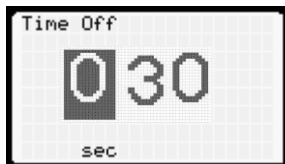

Figure 6-1 Duty cycle with the On cycle being $\frac{1}{4}$ of the complete cycle. An example of a duty cycle expressed in seconds is 10 seconds on and 30 seconds off.

- Select **On**.
- Enter the value for the amount of time, in seconds, the relay is on (activated). Press **Enter** to accept this value.



3. Enter the value for the amount of time, in seconds, the relay is off (deactivated). Press **Enter** to accept this value.



4. Confirm displayed value by pressing **Enter** or cancel by pressing **Back**

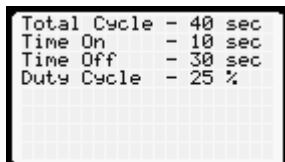

6.1.4 Relay Off Delay

There are instances in which a process value can initially spike upon addition of a chemical. An example is acid that is dispensed very close to a pH sensor such that, when the acid is first dispensed the probe pH drops precipitously and then rises as the acid is mixed. This is the opposite of a problem that occurs if the probe is far from the injection point such that there is a long delay in the change in pH and that calls for cycle on/cycle off control. Placing the sensor in the correct position would preempt the need for a relay delay but, for systems that are not easily modified, this option is a good solution.

1. Select **On**.
2. Enter the value for **Relay-Off Delay**, the amount of time the relay is off (deactivated), in seconds. Press **Enter** to accept this value.



6.1.5 Overfeed Timer

If a probe malfunctions it is possible for a relay to activate and stay permanently activated. Using the above example of a relay connected to an acid dispenser: The relay is programmed to activate at 9 and deactivate at 8. If the probe failed and remained stuck at pH 8 or higher, then the chemical pump that dispenses the acid would operate until it emptied out the entire container of acid. Perhaps worse is that the actual pH of the process would drop to a dangerously low level and cause serious damage to the processing equipment.

The overfeed timer option prevents this serious mishap. By specifying the maximum amount of time a relay can remain activated the damage caused by a faulty probe signal is contained. We strongly recommend always setting this option.

1. Select **On**.
2. Enter the value for the maximum time, in minutes, the relay can remain activated.

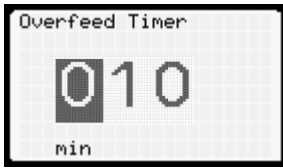

3. Press **Enter** to accept this value.

6.1.6 Relay Override

This simple control manually forces the relay on or off. It can be used as a switch to turn the process control function off and on and is normally used for either testing or emergency purposes.



Auto: Disable override so that the relay behaves as set up.

On: Activate the relay.

Off: Deactivate the relay.

6.1.7 Summary

The Summary menu item lists the relay parameters described in this section. The list of parameters requires two screens of information.

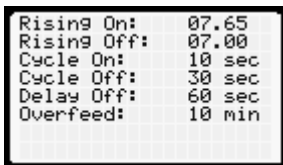

Press **Back** or **Enter** to continue.

6.2 4-20 mA Output – Channel 1

The 2250 hosts two 4-20 mA outputs. Output #1 emanates from the main circuit board. Output #2 emanates from the power board and is thus not available in the 2250 TX. Output #1 always transmits the process variable while output #2 can transmit the temperature of a pH, ORP or conductivity probe. The latter sometimes transmits the process variable to a different destination or using a different scaling than output #1. Both outputs can be scaled so that the two process values corresponding to 4 mA and 20 mA may take on any value.

6.2.1 Channel 1 – [PV] – 4 mA

PV is the process variable—pH, ORP, conductivity or flow.

1. Enter the value of the process variable that corresponds to 4 mA.

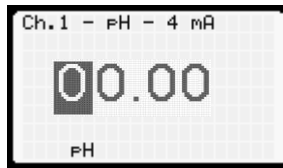

- a. The default value is 0 for pH, conductivity and flow.
- b. For an ORP probe the 4 mA value default is -1000 mV.

You may adjust the 4 mA value to the lowest value you expect to observe and defaults to 0. If, for instance, you are monitoring the pH of a process that never falls below 3 then change the 4 mA value to 3.

2. Press **Enter** to accept this value or **Back** to start over.

6.2.2 Channel 1 – [PV] – 20 mA

1. Enter the value of the process variable that corresponds to 20 mA. This is usually the highest value you expect to observe. Its default value depends on the setup parameters for the probe.

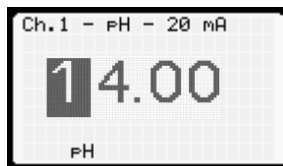

- a. For a pH probe it's 14.
- b. For an ORP probe it is 1000 mV.
- c. For a conductivity probe it is the upper limit for the cell constant chosen. For instance a probe with a cell constant of 10 will create a default 20 mA value of 50 mS/cm.

You may adjust the 20 mA value to correspond to the highest value you expect to observe. If, for instance, you are monitoring the pH of a process that never rises below 10 then change the 20 mA value to be 10.

3. Press **Enter** to accept this value or **Back** to start over.
4. The next screen summarizes your choice of 4 and 20 mA values.

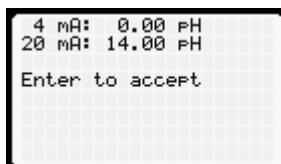

Note that the 4 mA value can be higher than the 20 mA value. This simply reverses the direction of the 4-20 mA signal as the process variable changes.

6.3 4-20 mA Output – Channel 2

The same instructions apply to Channel 2. For this channel you may set the output to follow either the process variable or temperature. That choice is made in the first menu item.



Default selection is for temperature range 0 to 100 °C. Negative temperature inputs are possible.

6.4 4-20 mA Output for Proportional Control

Some pumps, especially metering pumps, can be controlled by a continuously variable 4-20 mA input from a transmitter. This type of control is called **proportional control** because the magnitude of the current output is proportional to the difference between the target setpoint of the process variable and the actual process variable, aka the **error**. Let's look at the case of a process whose pH naturally rises and is controlled by dispensing acid. For control by a relay described in Section 6.1.1 the relay-on pH value was set at 9.0 and the relay-off value was set at pH 8.0. The process would thus cycle between pH 8.0 and 9.0.

With 4-20 mA proportional control you can achieve a much narrow range of operation without risking overshoot. You might decide on a setpoint of 8.5. You would adjust the 4 mA value for 8.5. As the pH rises above 8.5 the error would increase and the corresponding current output would increase proportionally. The output of the pump would vary according to the magnitude of the error and enable the process to be close to 8.5 at all times.

6.5 PID Control

PID control extends the concept of 4-20 mA proportional control to a high level. PID stands for Proportional-Integral-Derivative. PID control is a function of the following three components.

- **Proportional.** This component of the current output is proportional to the error, $e(t)$, as described in the previous section.
- **Integral.** This component of the current output is proportional to the integral of the error. This is roughly equivalent to the sum of the error going back in time. Mathematically it is:

$$I(t) = \int_0^t e(\tau) d\tau$$

- **Derivative.** This component of the current output is proportional to the instantaneous change in error. Mathematically it is:

$$D(t) = \frac{de(t)}{dt}$$

The total current output is the weighted sum:

$$I_{4-20}(t) = K_p e(t) + K_I I(t) + K_D D(t) = K_p e(t) + K_I \int_0^t e(\tau) d\tau + K_D \frac{de(t)}{dt}$$

The coefficients K_p , K_I and K_D are weighting factors for each of the three components. For purely proportional control $K_I = K_D = 0$.

To set up PID control requires setting values for the three coefficients:

1. Turn PID control **On**.
2. Set the value for K_p . Press **Enter** to accept it.
3. Set the value for K_I . Press **Enter** to accept it.
4. Set the value for K_D . Press **Enter** to accept it.
5. Set the value for the PID target, which is the desired value of the parameter (in the example above, 8.5).
6. Confirm PID summary screen by pressing **Enter**.

```
PID Summary
K-P 1.00
K-I 1.000
K-D 1.000
Target 08.50 pH
Enter to accept
Back to cancel
```

Setting up PID control takes considerable skill and should not be done by “amateurs.” Choosing the wrong PID parameters can cause a process to overshoot wildly and never reach equilibrium.

6.6 Manual Test

Manual Test allows you to insure that the outputs operate as intended without requiring the probe to deliver the actual output needed to test a relay or 4-20 mA output. For instance, if you set a relay for a rising process that activates when the pH reaches 9.0 you might test it by immersing it in pH 9.1 solution and verifying that the relay activates. With manual testing that is unnecessary. Simply dial in the pH value to 9.0 and observe the state of the relay on the screen. Temperature values can also be simulated.

The Manual Test screen also displays temperature and both 4-20 mA reading. In the example below Relay 1 was set to activate at pH 9.0. Relays 2 or 3 were either set to activate at a higher pH, a falling process below 9.0 or were not turned on at all. The Channel 1 4-20 mA corresponding to pH 9.0 is 14.3 mA (based on the 4-20 range corresponding to 0 to 14). The 4-20 Channel 2 mA corresponds to the temperature (Based on the 4-20 range corresponding to 0 to 100C).

```
pH: 09.00 pH
Temp: +025.0 C
Relay 1: ON
Relay 2: OFF
Relay 3: OFF
Ch 1 4-20: 14.3 mA
Ch 2 4-20: 8.0 mA
Enter to change field
```

7 Diagnostics

The Diagnostics menu has four options.

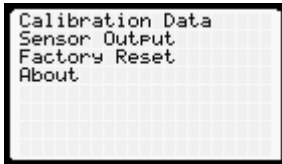

7.1 Calibration Data

This menu has one screen, which displays the results of the latest calibration.

- **pH.** This includes the number of calibration points (2 or 3), slope, offset, efficiency and calibration temperature.
- **ORP.** This includes the offset and calibration temperature
- **Conductivity.** This includes the number of calibration points (1 – 16), actual cell constant, calibration temperature and temperature coefficient.
- **Flow.** This includes the K-factor.

7.2 Sensor Output

This diagnostic displays the raw signal coming from a probe. It is invaluable for diagnosing probe problems.

- **pH.** A pH probe outputs a voltage. The temperature element (if present) outputs a resistance. For diagnosing a problematic pH probe the voltage output should be $(7.0 - \text{pH}) \times 59 \text{ mV}$ within a tolerance of about 50 mV. A smaller value indicates low efficiency, which may be ameliorated by cleaning, changing the reference solution or changing the salt bridge. If the probe output does not change upon changing calibration standards then the probe is dead.

The resistance of the temperature element should be close to the nominal resistance, which, depending on the element is either 100, 300, 1000 or 3000 Ω . A resistance reading far removed from its nominal value is indicative of a defective element.

- **ORP.** An ORP probe also outputs a voltage. The temperature element (if present) outputs a resistance. Unlike a pH probe the ORP value is not temperature compensated.

The resistance of the temperature element should be close to the nominal resistance, which, depending on the element is either 100, 300, 1000 or 3000 Ω . A resistance reading far removed from its nominal value is indicative of a defective element.

- **Conductivity.** A conductivity sensor measures resistance (which is inversely proportional to conductance). The temperature element outputs resistance as well.

The resistance of the temperature element should be close to the nominal resistance, which, depending on the element is either 100 Ω, 300 Ω, 1000 Ω or 3000 Ω. A resistance reading far removed from its nominal value is indicative of a defective element.

- Flow. A paddle-wheel or magnetic flow meter outputs a pulse train. The raw output is the pulse frequency.

7.3 Rest User Cal

This feature will only be used to restore 2250 unit to a factory default state. It resets all user calibrations, 4-20 outputs and relay setpoints value.

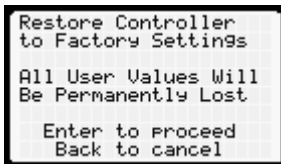

There is also a hardware reset that can be performed. While powering unit press and hold **Back** button until logo appears on the screen. Then release **Back** button – the unit will start as it comes from the factory, i.e. all calibration and output user values will be erased.

7.4 About

This feature displays the current firmware version and its release date. If you experience issues with your 2250 and 2250TX you would want to know which firmware version is running before contacting us.

8 Preferences

The Preferences menu has three options that only affect the user experience.

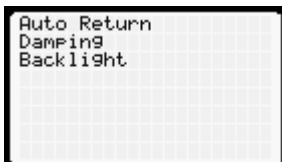

8.1 Auto Return

This feature allows you to return the 2250 to Run mode if you walk away from the 2250 while exercising a menu item. The choices are:

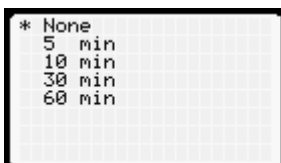

If you choose “None” then the menu which was active when you left will be active indefinitely. If you choose one of the other options, e.g. 10 min, then the screen will revert to the run screen after 10

minutes of inactivity. This feature is invaluable if the 2250 is transmitting data to a PLC or SCADA. When a menu item is being exercised the controller ceases to send data, which can cause an undue alarm or relay at the PLC or SCADA.

8.2 Damping

Damping imposes signal averaging, which dampens fluctuating values. The choices are:

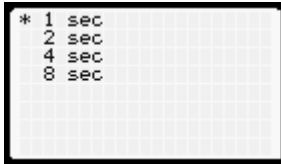

As an example, if damping is set to 4 seconds, then the 2250 averages all data points within the preceding 4 seconds. Note that this is a rolling average, i.e. the average continuously discards the oldest data point and adds a new one. Both the reading on the display and the 4-20 mA output show averaged values.

8.3 Backlight (2250 only)

This feature allows you to change the brightness level of the LCD screen. This is useful for matching the screen brightness to the ambient brightness. For darkened interiors, turning down the brightness helps prevent eye strain.

