



Features

- Small size enables convenient installation and service
- O-ring seals used on all versions for high on-stream reliability
- Low Maintenance - Reduced cleaning requirements
- Wide Measuring range
- Automatic Temperature Compensation
- Plastic gland fitting allows removal and replacement without tools

Description

The AM3422 sensors offer a compact design that allows installation into standard pipe fittings in small line sizes such as 3/4" and 1", avoiding the need for special flow cells.

Simplicity of the design also allows them to be economically offered in exotic metals for especially corrosive chemical applications.

Wetted materials of construction are 316 stainless steel and Teflon, with double o-ring seals at all points. The outer EPDM o-ring bears the brunt of process interface, allowing the back o-ring to maintain reliable sealing free from chemical attack. An integral temperature element tailored to the analyzer of choice allows automatic compensation for maximum accuracy. Leads are 10' standard, stripped and tinned ends or optional spade lugs.

Process connections are made via a bored through swage fitting with 1/2" or 3/4" NPT threads. This fitting can be screwed into a line, or tank, and it can also be turned around and connected to a standpipe for use in a submersion configuration. The AM3422 is good for general purpose and covers a broader range of conductivities.

Applications

- Plating
- High purity water applications
- Pharmaceutical Applications
- Reverse Osmosis systems
- Fume Scrubbers
- Cooling Towers
- Textile Manufacturing
- Food and Beverage

Model 3422 Conductivity Sensors

Technical Data

Wetted Materials	
Insulator	Teflon™®
O-rings	EPR
Electrodes	316SS standard, Titanium optional
Fitting	3166 Stainless Steel
Maximum Pressure / Temperature	100 PSIG at 120°C
Cell Constants	0.05 / 0.1 / 0.5 / 1.0 / 5.0 / 10.0 / 50.0
Connections	
Process Fitting	1/2" or 3/4" Male NPT
Electrical	Stripped and tinned leads
Temperature Compensation	3KΩ NTC Thermistor or Pt1000

Dimensions

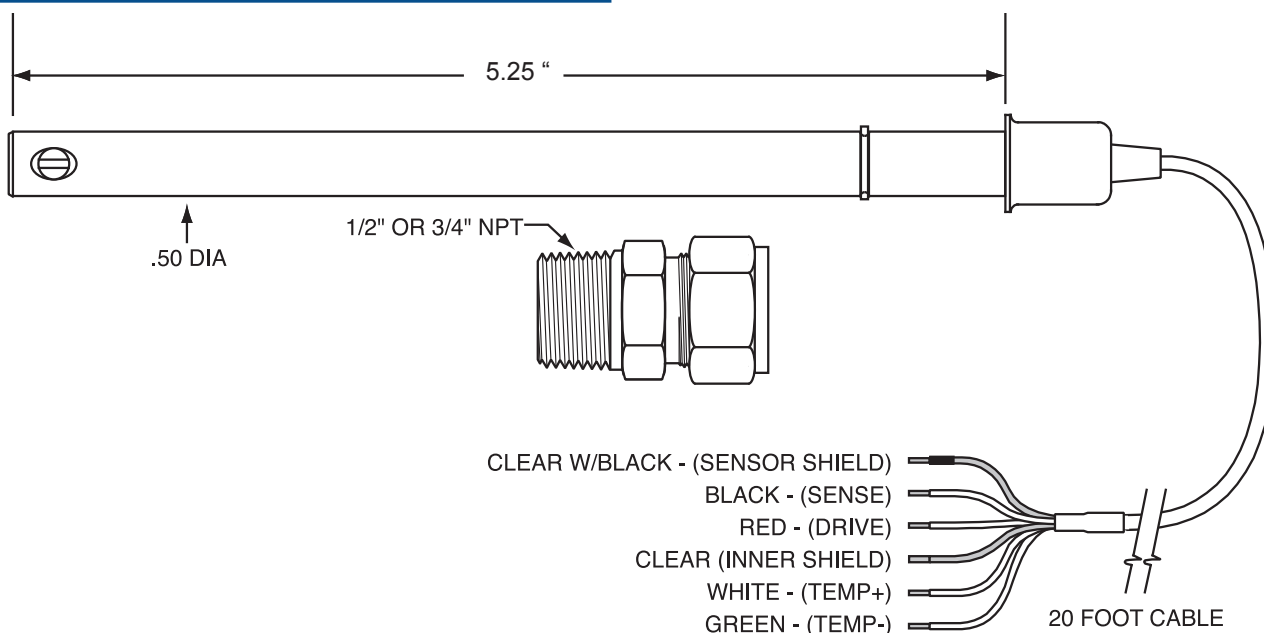

Order Information

Cell Constant Selection

Constant	Code	Constant	Code
0.05	005	1.0	1
0.1	01	5.0	5
0.5	05	10	10

Related Products

MS Series of epoxy body conductivity probes