

Operation Manual

MODEL 6312DTB/DTF

DO/Temperature Controller

JENCO ELECTRONICS, LTD.
MANUFACTURER OF PRECISION INSTRUMENTS

CONTENTS	Page
I. INITIAL INSPECTION	2
II. GENERAL INTRODUCTION	3
III. USING THE JENCO MODEL 6312DTB/DTF	4
A. FRONT PANEL	4
B. NORMAL MODE DISPLAY	5
C. REAR CONNECTORS	6
D. TURNING ON/OFF THE INSTRUMENT	7
IV. MODEL 6312DTB/DTF MODES	8
A. MAIN DISPLAY MODE	8
B. CALIBRATION/SETTING MODE	8
C. HOW TO USE THE KEYS	9
a. PASSWORD CHECK page	10
b. USER SETTING page	10
c. DO CALIBRATION page	11
d. DO CONTROL SETTING page	13
e. DO mA OUT SETTING page	14
f. TEMP. mA OUT SETTING page	14
g. TEMP. CONTROL SETTING page	15
V. CONTROLLING THE RELAYS	15
A. RELAY ISOLATION VOLTAGE	15
B. RELAY OUTPUT LOAD	16
C. RELAY ACTION, SET POINT & HYSTERESIS	16
D. DO RELAYS	16
E. TEMPERATURE RELAY	17
VI. DO & TEMP. 4-20 mA OUTPUT	17
A. ISOLATION VOLTAGE	17
B. OUTPUT LOAD	17
C. DO & TEMP. LINEAR CURRENT OUTPUT	17
VII. RS485 INTERFACE OPERATION	18
A. INTRODUCTION	18
B. PREPARING THE METER	18
VIII. ERROR DISPLAYS AND TROUBLESHOOTING	19
IX. SPECIFICATIONS	20
X. WARRANTY	21
XI. RETURN OF ITEMS	21

I. INITIAL INSPECTION

Carefully unpack the instrument and accessories. Inspect for damages made in shipment. If any damage is found, notify your Jenco representative immediately. All packing materials should be saved until satisfactory operation is confirmed.

MOUNTING PROCEDURE

1. Make a cutout on any panel, with a thickness of 1/16 in. (1.5 mm) to 3/8 in. (9.5mm).
2. Remove the mounting assembly from the controller and insert the controller into the cutout.
3. Replace the mounting bracket assembly onto the controller and secure the controller to the mounting panel.

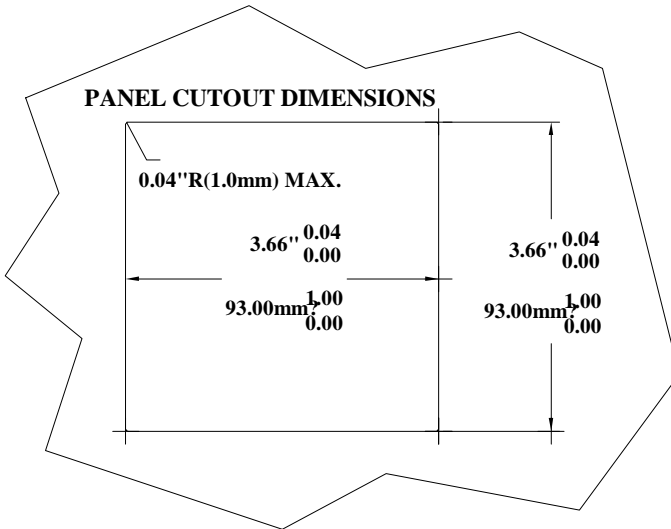

Warning:

If the equipment is used in a manner not specified by the manufacturer, the protection provided by the equipment may be impaired.

Cleaning the instrument:

1. Be sure to remove the power before attempting to clean the meter.
2. Use a lint free cloth and clean water or neutral detergent.
3. Wipe the outer surface of the instrument only.
4. Wipe-dry the instrument before powering again.

II. GENERAL INTRODUCTION

The Jenco Model **6312DTB/DTF** (DO and Temperature) System is a rugged microprocessor based instrument assembled in a watertight ¼ DIN case, designed for use in laboratories and process control applications.

The model 6312DTB/DTF microprocessor allows the user to easily recalibrate the parameters for the probes. The DO system can do single or dual point calibration, regardless of which dissolved oxygen display you use. The microprocessor also performs a self-diagnostic routine every time you turn on the unit providing you with basic information about the stability of the instrument.

The system simultaneously displays DO, Temperature, relay status and current output in one LCD graphic screen. The LCD also includes a backlight for badly lit environments. This system uses a “polygraphic clark” membrane for the DO and a precise thermistor for temperature, providing you with accurate readings for all your measurements.

The model 6312DTB/DTF is equipped with three programmable high or low relays for DO and one programmable high or low relay for temperature; all relays are hysteresis driven. The system also have two **isolated 4-20mA** analog output for DO & temperature each, offset and span configurable for the DO & temperature display.

The model 6312DTB/DTF comes with a **RS485** interface that can easily let the user log all data with an IBM[®] PC/AT compatible computer. For advanced users, the model 6312DTB/DTF may also be remotely controlled from main display mode to all calibration/setting modes.

III. USING THE JENCO MODEL 6312DTB/DTF

A. FRONT PANEL

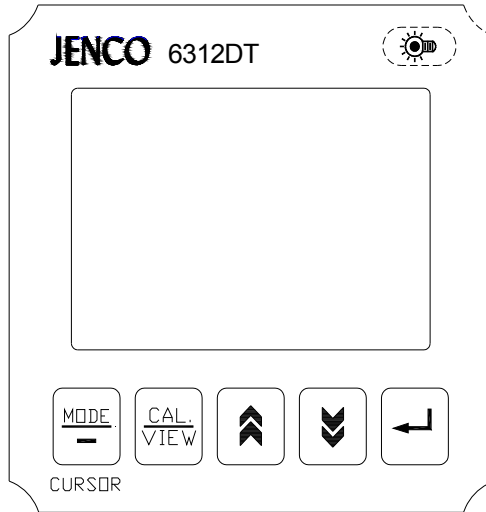

1. The **[MODE /-]** key.
 - 1a. In Main Display mode this key will change the DO display to DO%, DO ppb or DO ppm.
 - 1b. In **Calibration/Setting** mode this key will move to the next digit of the current active parameter.
 - 1c. In **Calibration/Setting** mode, pressing this key for two seconds will move you back to the previous parameter.

2. The **[CAL / VIEW]** key.
 - 2a. In Main Display mode, the display will go to Calibration/Setting mode if you press this key for about two seconds.
 - 2b. During Calibration/Setting mode this key will switch to the next available Calibration/Setting page. Pressing this key at the last Calibration /Setting page will return the user to the main display mode.

3. The **[^] UP** key.

During Calibration/Setting mode this key will **increment** the current blinking digit of the active parameter.

4. The [▼] **DOWN** key.
 - 4a. During Calibration/Setting mode this key will **decrement** the blinking digit of the active parameter.
 - 4b. During " DO CALIBRATION" the user can press this key to skip ZERO calibration.

5. The [↵] **ENTER** key.

During Calibration/Setting mode, this key will save the current modified parameter and move to the next parameter on the page if the parameter is the last one in the page then it will move to first parameter on the next available page.

6. The [☀] **LIGHT** key.

This key will turn on or turn off the backlight of the LCD.
The backlight will automatically turn off if there is no key activity within two minutes.

7. LCD screen.

B. NORMAL MODE DISPLAY

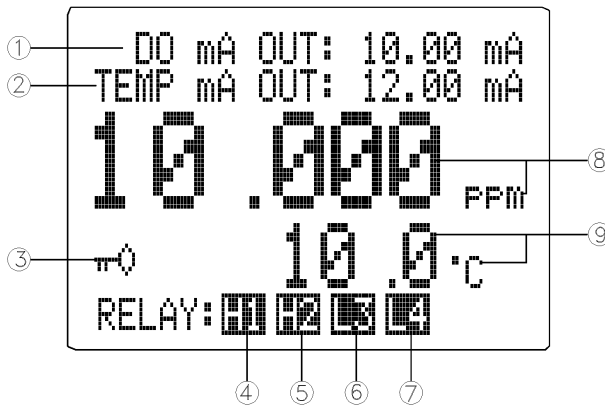

1. **DO mA OUT** - this will display the output of the DO 4- 20 mA circuit.
2. **TEMP mA OUT** - this will display the output of the Temperature 4-20 mA circuit. At POWER-ON DO & TEMP mA OUT will show "OFF" for about three seconds before going to main display mode. After exiting the Calibration/Setting pages, a "FROZEN" message will be displayed for about three seconds if the unit is not password locked.

3.  annunciator - this will be displayed if Calibration /Setting pages are password locked meaning the user **can't** change the values unless the correct 4 digit number has been entered.
4. **H1 (High action relay 1)** or **L1 (Low action relay 1)** annunciator - this is the status of the DO Relay 1, if this is displayed then the Relay is ON. **H1** means the relay action is HIGH while **L1** means the relay action LOW.
5. **H2 (High action relay 2)** or **L2 (Low action relay 2)**annunciator –this is the status of the DO Relay 2, function is same with RELAY 1.
6. **L3 (Low action relay 3)** or **H3 (High action relay 3)** annunciator –this is the status of the DO Relay 3,function is same with RELAY 1.
7. **L4 (Low action relay 4)** or **H4 (High action relay 4)** annunciator – this is the status of the Temperature Relay 4, if this is displayed then the Relay is ON. **H4** means the relay action is HIGH while **L4** means the relay action LOW.
8. **Dissolved oxygen display and unit (% , ppb or ppm).**
9. **Temperature Display and unit (°C) .**

C. REAR CONNECTORS

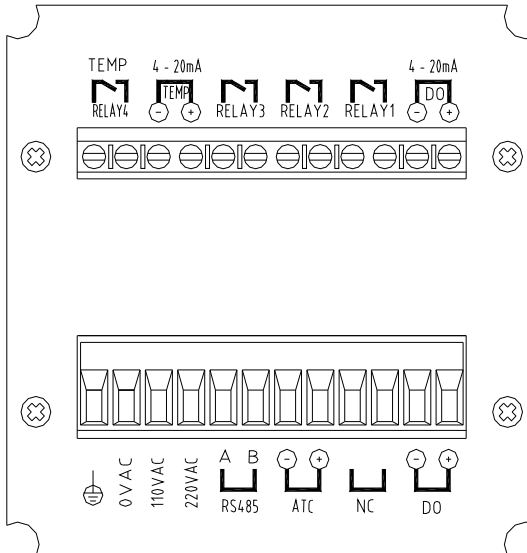

Before wiring the probes, relays, analog output, RS485 and power cord be sure that you are connecting to the right terminal as shown above. Remember that the unit is ON once the user plugs in the power cord to an AC power supply.

1. Connect the AC line to the rear of the instrument. The model 6312DTB/DTF can be used with 115 or 230VAC 50/60 Hz. Power consumption is 6 watts. Make sure the **EARTH** connector is connected to the earth lead of the AC power line.
2. Connect the proper load to the output relays. Make sure that the load does not exceed the relay rating, 5 Amp at 115VAC and 2.5Amp at 230 VAC.
3. Set the proper load to the 4-20mA output connector. Make sure that the load impedance is less than 500 Ohms.

CAUTION: Make sure you connect the AC power cord to the correct AC terminals. Connecting incorrectly may damage the unit permanently.

D. TURNING ON/OFF THE INSTRUMENT

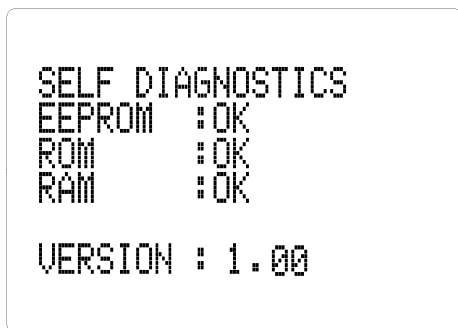

By just plugging the unit to a correct AC voltage the unit will be ready for use. There is **no Power key** so unplugging and plugging the unit will turn OFF or turn ON the unit respectively.

After the unit is turned on, it will perform some basic self- diagnostics and will display “OK” or “BAD”. If you received any “BAD” messages turn OFF the unit and turn it ON again. (See **VIII. ERROR DISPLAYS AND TROUBLESHOOTING**).

If the message persists then you might need to call your distributor. (See **X. WARRANTY**).

After the self-diagnostic is complete the temperature will be displayed on the lower part of the LCD screen and you are ready to make DO calibration or measurements. Just immerse the probes halfway to the liquid. If possible do not allow the probes to touch any solid object in the solution. There should be no air bubbles around the probes either. Shaking or moving the probes vigorously before recording any measurement will dislodge any bubbles formed in the probes.

IV. MODEL 6312DTB/DTF MODES

A. MAIN DISPLAY MODE

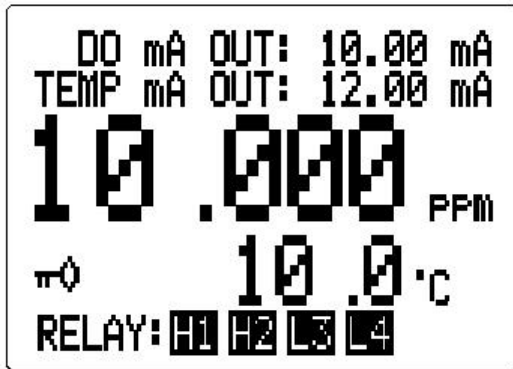

Turning ON the unit will always start in main display mode.

This instrument is designed to provide four distinct measurements:

1. **Temperature** - current temperature of the solution, which is always displayed.
2. **Dissolved Oxygen %** - a measurement of oxygen in percent saturation.
3. **Dissolved Oxygen ppm** - a measurement of oxygen in ppm.
4. **Dissolved Oxygen ppb** - a measurement of oxygen in ppb.

Temperature and DO (% , ppm or ppb) are always simultaneously displayed in the graphic LCD screen in normal mode. You can select which DO unit to display by pressing the [MODE/-] key.

B. CALIBRATION/SETTING MODE

Pressing the [CAL/VIEW] key for about two seconds during main display mode will bring-up the first page of seven pages of the **Calibration/Setting** mode. Pressing [CAL/VIEW] key will switch to the next page until the last page, where pressing [CAL/VIEW] again will return the user to main display mode.

Below is a simple flowchart showing the path of the [CAL/VIEW] key:

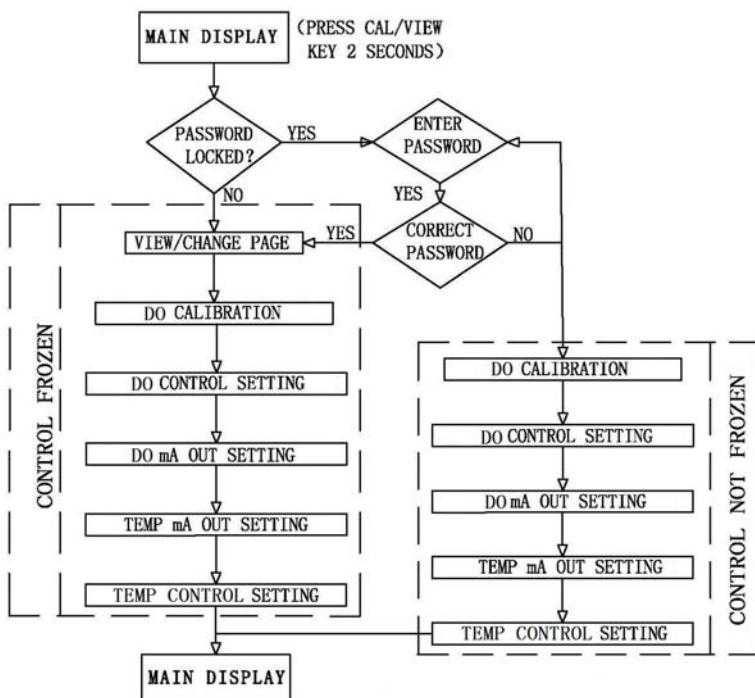

C. HOW TO USE THE KEYS

1. At MAIN DISPLAY you need to press and hold the [CAL/VIEW] key for two seconds to change the display to VIEW SETTING PAGE or if the instrument is password locked the display will be PASSWORD CHECK page.
2. You can change any blinking options or digit by pressing the [▲] or [▼] keys.
3. During main display mode you can press [MODE/-] key to select the DO display unit.
4. For options in digit format you need to press the [MODE/-] key to move the cursor to the next digit.
5. If you are satisfied with the selection you made you need any blinking options or digit by pressing the [▲] or [▼] keys. For options in digit format you need to press the [MODE/-] key to move to the next digit. If you are satisfied with the selection you made you need to press the [↵] **ENTER** key to save the changes and move to the next option.

6. If you don't need to change the current blinking option, just press the [↵] **ENTER** key to move to the next selection.

7. You also can press and hold [MODE/-] key for two seconds and it will move back the cursor to the previous option.

a. **PASSWORD CHECK** page



You will only see this page if the unit is password locked. To change any settings or calibration you need to unlock the system to remove the “**PASSWORD LOCKED**” message. You need to enter the correct 4-digit number on the “**ENTER PASSWORD**” input. You can still view all the pages of **Calibration/Setting mode** if the system is password locked by just pressing the [CAL/VIEW] key on this page. If the unit is “**PASSWORD LOCKED**” going to

Calibration/Setting mode will not affect the function of the relays and current output.

CAUTION: If the unit is not locked then every time the user enters the **Calibration/Setting mode** the relays and analog out will be **frozen**.

b. **USER SETTING** page

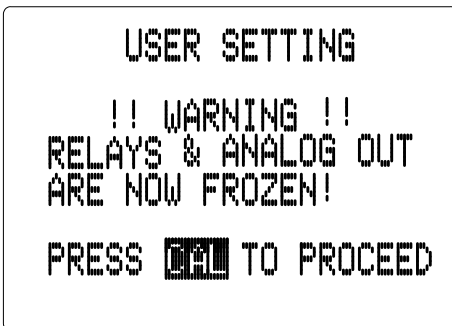

You will only see this page if the unit is not password locked. This page is just a **WARNING**, telling you that all relays are frozen, and that you can calibrate and change the settings.

NOTE: FROZEN MEANS ALL THE RELAYS AND THE ANALOG OUT WILL MAINTAIN THEIR LAST STATE UNTIL THE USER RETURNS TO MAIN DISPLAY MODE.

c. DO CALIBRATION page

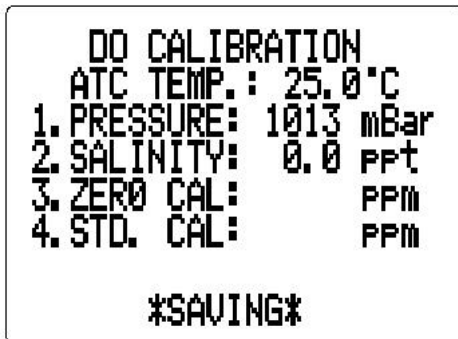

ATC TEMP. – the current temperature of the solution.

1. **PRESSURE** - user changeable pressure value for DO computations.
2. **SALINITY** - user changeable salinity value for DO computations.
3. **ZERO CAL** - This calibration is used for a 2-point standard DO calibration. If you are doing a

product calibration then you need to skip this calibration by pressing the [▼] DOWN key. If you are doing a 1-point standard calibration then you need to also skip this calibration. If you are doing a 2-point standard calibration then you need to place the probe in a 0% oxygen solution and press [↵] to start the zero calibration. If you want to calibrate in a different DO unit on what is displayed now, then you need to go back to the normal display and press the [MODE] key to change to the correct DO unit return to this option. Wait for reading to be stable before pressing the [↵] key again. You can only calibrate if the reading is lower than 4.5% (or equivalent value in ppm, ppb).

4. **STD. CAL or PROD. CAL:** In this calibration you can choose first if you are doing a “**STD. CAL**” (Standard Calibration) or a “**PROD. CAL**” (Product Calibration).

To accurately calibrate the model 6312DTB/DTF you will need the following information:

- i. The approximate pressure (in mBar) of the region in which you plan to take your dissolved oxygen measurements.
- ii. The approximate salinity of the water you will be analyzing. Fresh water has a salinity of approximately zero. Sea water has a salinity of approximately 35 parts per thousand (ppt).

(a). **STD.CAL** – The unit of this calibration will depend on the unit of DO at normal/main mode.

Follow these steps to do a Standard Calibration:

1. If the DO probe is new and not yet connected to the meter, follow the DO probe manufacturer's instruction on how to prepare the probe for first use and how to connect to the meter.
2. Turn on the unit and place the probe in suitable 100% air saturated container.
3. Wait for the temperature reading and the un-calibrated DO reading to stabilize.
4. Press the [CAL/VIEW] key for about two seconds to enter CALIBRATION/SETTING mode and press [CAL/VIEW] key again until you reach DO CALIBRATION page.
5. Input local PRESSURE and SALINITY.
6. If you are doing a zero calibration refer to 3.**ZERO CAL**.
7. Press the [▲] UP or [▼] DOWN to select "STD. CAL" then press the [↵] ENTER key to save the selection.
8. If you are calibrating in % then the 100% calibration will be displayed. An error will be displayed if the input is not within the normal DO range. A [↵] icon will flash, pressing the [↵] ENTER key will start the calibration. If the input is not within the DO calibration limit then an error message will be displayed. If all is well then it will save the new calibration and move to the next page.
9. If you are calibrating in ppm (ppb) then the current reading in ppm (ppb) will be displayed. If you press the [↵] ENTER key, the unit will capture the current value and then you can change the value by using the [MODE/-], [▲] UP and [▼] DOWN keys. If you are satisfied with the ppm (ppb) value, you need to press the [↵] ENTER key to save the new calibration. If the DO input is within calibration range then the new calibration will be saved and move to the next page, otherwise an error message will be displayed.

(b). PROD.CAL – You can only select PROD.CAL if you did not do a ZERO CAL first. If you are trying to do a PROD.CAL but started a ZERO CAL you need to go back to ZERO CAL and press the [▼] DOWN key to skip it. The unit of this calibration will depend on the unit of DO at normal/main mode.

Follow these steps to do a Product Calibration:

1. Wait for the temperature reading and the un-calibrated DO reading to stabilize.
2. Press the [CAL/VIEW] key for about two seconds to enter CALIBRATION/SETTING mode and press [CAL/VIEW] key again until you reach DO CALIBRATION page.
3. Input local PRESSURE and SALINITY.
4. Press the [▼] DOWN key to skip ZERO CAL.
5. Press the [▲] UP or [▼] DOWN to select “PROD. CAL” then press the [↵] ENTER key to save the selection.
6. A [↵] ENTER icon will flash, pressing the [↵] ENTER key will start the product calibration. If the reading is higher than 5% (or equivalent value in ppm) then it will capture the reading and let you change the value to your specified value.
7. Press [↵] ENTER key to save your product calibration and move to the next page.

d. DO CONTROL SETTING page

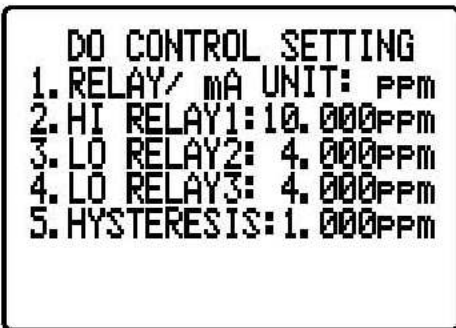

1. RELAY/mA –User needs to press [▲] and [▼] keys to select one of three DO units, %/ppm/ppb, for the relay control and current output.

2. HI or LO RELAY 1 – the action for this relay is changeable, you can choose “HI” action or “LO” action. (In HI-action the relay will turn ON if the DO reading is greater or equal to RELAY1 value, in LO-action the relay will turn OFF if the DO reading is

greater or equal to RELAY1 value, which is modified by the hysteresis value.)

(See chapter **V. CONTROLLING THE RELAYS**).

User can use [\wedge] and [∇] keys to select the relay1 action and press [$_$] key to save the setting. After you select the RELAY1 action you can now select the RELAY1 set point. Use [\wedge] and [∇] keys to change the blinking digit, use the [**MODE/-**] key to select another digit and the [$_$] key to save the new set point value.

3. **HI or LO RELAY 2** – function & setting procedures same with RELAY 1

4. **HI or LO RELAY 3** - function & setting procedures same with RELAY 1

5. **HYSTERESIS (value)** - this is the actual value of the hysteresis. You can change this value from 0.1% to 99.9%, 0.01 to 9.999ppm or 0 to 9999ppb. (See chapter **V. CONTROLLING THE RELAYS** .)

e. **DO mA OUT SETTING** page

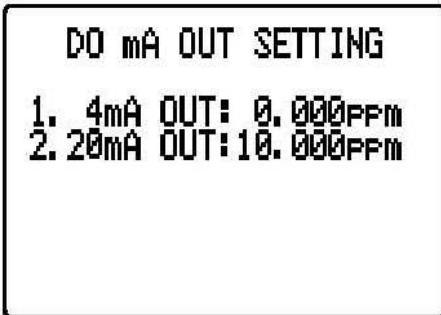

1. **4mA OUT** – This value will be used in conjunction with 20 mA to plot the current output. (See chapter **VI. 4-20 mA OUTPUT.**)

2. **20mA OUT** – This value will be used in conjunction with the 4 mA value to plot the output. (See chapter **VI. 4-20 mA OUTPUT.**)

f. **TEMP. mA OUT SETTING** page

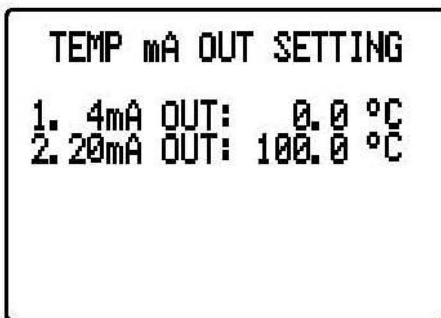

1. **4mA OUT** – This value will be used in conjunction with 20 mA to plot the current output. (See chapter **VI. 4-20 mA OUTPUT.**)

2. **20mA OUT** – This value will be used in conjunction with the 4 mA value to plot the output. (See chapter **VI. 4-20 mA OUTPUT.**)

g. TEMP. CONTROL SETTING page

```
TEMP. CONTROL SETTING
1. RELAY 4 :HIGH
2. SET POINT :100.0 °C
3. HYSTERESIS: 1.0 °C
4. RS 485 ID : 00
5. PASSWORD SET: 0000

*SAVING*
```

1. **RELAY 4** - the temperature has only one relay to control you need to set what action it will use, HIGH or LOW action. . (In HIGH-action the relay will turn **ON** if the temperature is greater or equal to RELAY4 set point, in LOW-action the relay will turn **OFF** if the temperature is less than or equal to RELAY4 set point, which is modified by the hysteresis value (See chapter **V. CONTROLLING THE RELAYS** .)

2. **SET POINT (For positive temperature only)**- this is the user changeable value for the Temperature Alarm relay.

3. **HYSTERESIS (value)**- this is the actual value of the hysteresis. You can change this value from 0.1 to 19.9°C. (See chapter **V. CONTROLLING THE RELAYS**.)

4. **RS 485 ID** – this is the unique ID/Address for the unit. If you are connecting multiple model 6312DTB/DTF or other Jenco models for logging purposes then this ID/Address must be unique for each connected unit. This ID/Address is the same address that must be used by the PC program to communicate with this unit.

5. **PASSWORD SET** - this is your security code if the unit is locked the value here will not be available. You need to input the correct code in the PASSWORD CHECK page.

CAUTION: The user is responsible in remembering their password number otherwise you would no be able to calibrate or change the settings.

V. CONTROLLING THE RELAYS

A. RELAY ISOLATION VOLTAGE

The maximum isolation voltage of the relay output contacts is 1500 VDC. The voltage differential between the relay output contacts and the load should not exceed 1500 VDC.

B. RELAY OUTPUT LOAD

The current through the relay output contacts should not exceed 5 Amp at 115 VAC and 2.5 Amp at 230 VAC in order not to cause permanent damage to the relay contacts. This rating is specified for **resistive** loads only.

C. RELAY ACTION, SET POINT & HYSTERESIS

Relay Action	Effective RELAY-ON Set Point	Effective RELAY-OFF Set Point
HIGH	S.P.	S.P. - (H.V)
LOW	S.P.	S.P. +(H.V.)

S.P. = Relay Set point H.V.= Hysteresis value (Dead Band)

If the relay action is set to **HIGH**, the relay will turn **ON** at (SET POINT), and will turn **OFF** at (SET POINT-HYSTERESIS).

If the relay action is set to **LOW**, the relay will turn **ON** at (SET POINT), and will turn **OFF** at (SET POINT + HYSTERESIS).

D. DO RELAYS

There are three independent Alarm channels for DO display. (see **Figure 1.**). The hysteresis value will be used by three DO relays.

The action of the DO relays is dependent on set point, relay action type (HIGH or LOW), hysteresis value and the current DO display. (see **Figure 1.**).

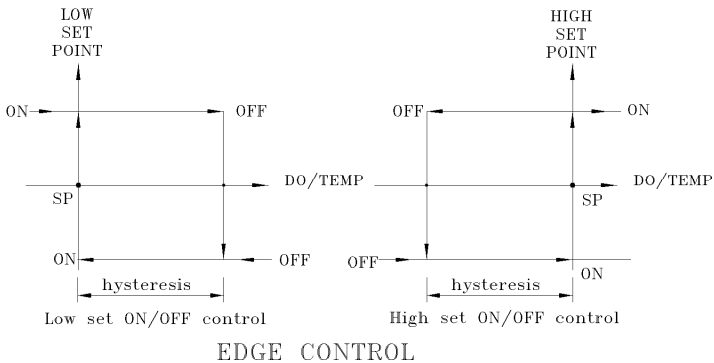

Figure 1

E. TEMPERATURE RELAY

One relay channel is available for temperature display which has independent set point, action (see **Figure. 1**) setting (HIGH or LOW) and hysteresis value.

The action of the Temperature relay is dependent on set point, relay action (HIGH or LOW), hysteresis value and the current Temperature display. (see **Figure. 1**)

VI. DO & TEMP 4 - 20 mA OUTPUT

A. ISOLATION VOLTAGE

The maximum isolation voltage of the 4-20 mA output is 500 VDC. The voltage differential between the 4-20 mA output and the load should not exceed 500 VDC.

B. OUTPUT LOAD

The maximum load is 500 ohm Output current inaccuracies may occur for load impedance in excess 500 ohm.

C. DO & TEMP. 4-20mA OUTPUT

The analog output will produce a linear analog output if the user selects this option. The DO analog output will be dependent on the **DO_4 mA setting**, **DO_20 mA setting** and the **current DO display**.

The DO & Temperature LINEAR analog output is based on the following equations:

$$mA_{(DO)} = 4mA + (16mA) * (D_{(DO)} - DO(4)) / (DO(20) - DO(4))$$

$$mA_{(Temp)} = 4mA + (16mA) * (D_{(Temp)} - TEMP(4)) / (TEMP(20) - TEMP(4))$$

Where:

$mA_{(DO)}$ & $mA_{(Temp)}$ = analog output

$D_{(DO)}$ & $D_{(Temp)}$ = current DO & Temperature display

DO(4) & TEMP(4) = DO & Temperature user setting for 4 mA

DO(20) & TEMP(20) = DO & Temperature user setting for 20 mA.

Note:

1. The range for 4mA and 20mA settings is 0.00 to 499.9%, 0.0000 to 59.999ppm, 0 to 59999ppb..
2. The absolute difference of the 4mA and 20mA settings must be greater or equal to 1.0%, 0.100ppm, 100ppb or else the analog output will be disabled.

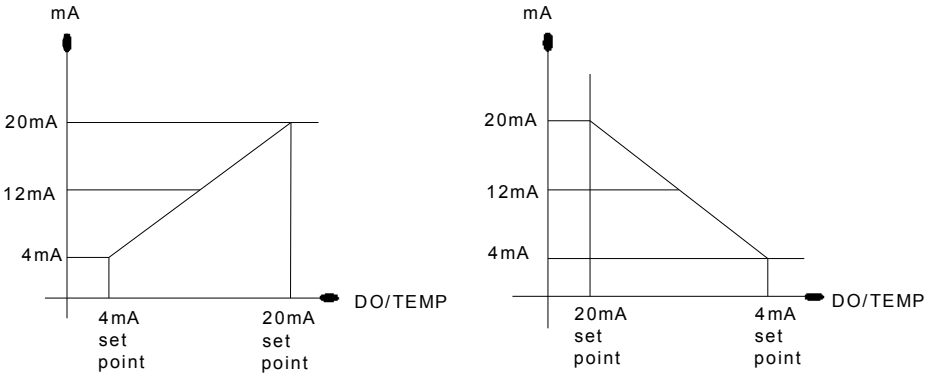

VII. RS485 INTERFACE OPERATION

A. INTRODUCTION

This section assumes you are familiar with the basics of computer programming, data communication, the RS485 interface and possess a copy of any programming language software capable of interfacing with a RS485 card or a RS232-RS485 converter (third party vendor) module.

A demo program for Windows (XP, 7) is included in the accompanying disk.

B. PREPARING THE METER

This meter comes equipped with a 2-wire RS485 interface. Just connect each terminal to the respective RS485 terminal on your PC. (If the DEMO program is not working, try reversing the connections of the terminals.) After you have connected the meter (or multiple meters with unique ID number) correctly and

turned on both the meter(s) and the computer, you are now ready to program a simple routine to read data from the instrument.

Read the included file "Model 6312DTB(F) protocol.doc" to help you make a program to communicate with the Model 6312DTB(F).

VIII. ERROR DISPLAYS AND TROUBLESHOOTING

LCD display	ATC display	DISPLAY unit	Possible cause(s) [Action(s)]
"UNDR"	a. >120.0 °C b. "OVER"	a.% or ppm(ppb) -DO cal b.% or ppm(ppb) - DO cal	a. Temperature >120.0°C. [Bring solution to a lower temperature.]
"OVER"	"UNDR"	% or ppm(ppb)- DO cal	Temperature < -10.0°C. [Bring buffer/solution to a higher temperature.]
CAL ERROR		PROD.CAL	If user did a ZERO CAL then trying a PROD.CAL [Go back to ZERO CAL and skip it by pressing the DOWN key]
OUT OF RANGE		a. ZERO CAL b. STD.CAL c. PROD.CAL	a. Reading higher than 5% or equivalent in ppm(ppb) or lower than 0%. b. raw probe input current higher than 30% or less than – 30% of typical input. c. Reading is lower than 5% or equivalent ppm(ppb). User new value is higher than 20% or lower than 20% of the current reading. [Correct the calibration solution.]
EEPROM: BAD		During power-on	Unit has failed its EEPROM test. [Turn instrument OFF and back to ON again.] [Return for service. (see X.Warranty)]
ROM : BAD		During power-on	Unit has failed its ROM test. [Turn instrument OFF and back to ON again.] [Return for service. (see X.Warranty)]

RAM :		During power-on	Unit has failed its RAM test. [Turn instrument OFF and back to ON again.] [Return for service. (see X.Warranty)]
BAD			

IX. SPECIFICATIONS

DO

Display	Range	Accuracy	Resolution
Dissolved O ₂ % air-sat	0 to 400.0%	±0.2 % of span (meter only)	0.1%
Dissolved O ₂ % (ppm,ppb)	Depends on DO%	±0.2 % of span (meter only)	0.001ppm, 1ppb

Temperature

Range	Resolution	Accuracy
-10.0 to 120.0 °C	0.1 °C	±0.1 °C

DO

Salinity compensation	0.0 to 49.9 ppt (manual)
Pressure compensation	600 to 4000 mBar (manual)
Temperature compensation	-10.0 to 80.0 °C (automatic)

Temperature

Temperature sensor	Thermistor, 22KΩ at 25°C
---------------------------	--------------------------

4-20mA Output

Current output type (DO)	Linear
Current output type (Temp.)	Linear
Current output range	4 to 20 mA (isolated)
Current output scale	user programmable
Maximum load	500 ohm
Accuracy	± 0.02mA
Isolation voltage	500VDC

Controller

Control type	Programmable ON/OFF control
Relay output	2.5A at 230VAC(5A at 115VAC)

GENERAL

Keys	Audio feedback in all keys
Security protect	4-digit password
Communication	RS485
Power:	230VAC(115VAC) 50/60Hz
Power consumption	6watts
Fuse	315mA/250V fast acting glass tube
Ambient temperature range	0.0 to 50.0 °C
Display:	128x64 graphic LCD w/ backlight
Case	IPT65 ¼ DIN case, depth 148mm
Weight	950 g

X. WARRANTY

Jenco warrants this product to be free from significant deviations in material and workmanship for a period of 1 year from date of purchase. If repair or adjustment is necessary and has not been the result of abuse or misuse, within the year period, please return-freight-prepaid and the correction of the defect will be made free of charge. If you purchased the item from our Jenco distributors and it is under warranty, please contact them to notify us of the situation. Jenco Service Department alone will determine if the product problem is due to deviations or customer misuse.

Out-of-warranty products will be repaired on a charge basis.

XI. RETURN OF ITEMS

Authorization must be obtained from one of our representatives before returning items for any reason. When applying for authorization, have the model and serial number handy, including data regarding the reason for return. For your protection, items must be carefully packed to prevent damage in shipment and insured against possible damage or loss. Jenco will not be responsible for damage resulting from careless or insufficient packing. A fee will be charged on all authorized returns.

【Note】 Jenco reserves the right to make improvements in design, construction and appearance of our products without notice.

Jenco Instruments, Inc.
7968 Arjons Drive, Suite C San Diego, CA 92126
USA
TEL: 858-578-2828 FAX: 858-578-2886
E-Mail: jencoinfo@jencoi.com; sales@jencoi.com
Website: www.jencoi.com

Jenco Electronics, Ltd.
4F., NO. 80, Songde Rd., Xinyi Dist., Taipei City 110, Taiwan
TEL: 886-2-2345-6188 FAX: 886-2-2345-6791
E-Mail: sales@jenco.com.tw
Website: www.jenco.com.tw

Shanghai Jenco Instruments, Ltd.
18 Wang Dong Zhong Road
Sijing Town, Songjiang
Shanghai, China
TEL: 86-021-5761-9599 FAX: 86-021-5761-9598
E-Mail: sales@jenco.com.cn
Website: www.jenco.com.cn

机型	6312DTB/DTF	文件名称	使用说明书(英)		
文件编号	K6312DTB/DTF-02	编制人	汪蕾	编制日期	2013-04-15
版本号	02	核准人		核准日期	