

Remote Drum Level Indicator (RDLI) & Switch (RDLS) Series

Model : SDG-3000/SDS-3000

SDG-3000/SDS-3000

Remote Drum Level Indicator & Switch (RDLI / RDLS Series)

Introduction

Steam/water interfaces in the various high pressure and high temperature steam drums operated in electricity-generating power plants, glass, cement, petro-chemical, steel, and paper making plants require close monitoring and controlling for safe, efficient and reliable operation. Since most of these steam drums normally operate at very high pressure and temperatures, any malfunction of the level measuring and controlling instruments must be prevented so that serious interruptions and costly damages to the process or equipment can be precluded.

In spite of the importance of close monitoring and controlling of the drum levels, industries in the past have relied on such devices as glass and float-type level switches. But they often malfunctioned, and required service or replacement interrupting the normal operation and processes. Based on many years of experience as the leading supplier of level and flow sensing instruments and in-company technological innovation, Seojin Instech has succeeded in developing this electrode-type steam drum interface monitoring system that operates reliably in the extremely high pressure and temperature environment of up to 300kg/cm² and 560 °C.

Capabilities

- Measures the steam/water interface level
- No moving part
- Maximum operating temperature : 560°C
- Maximum operating pressure : 300Bar (4350psi)
- On-site and remote indication and alarm
- Indication and alarm for accumulation of extraneous matters
- Individual indication of damaged (leaky) electrodes
- Indication of disconnected wire
- Output signals compatible with power plant requirements (Isolated analog for 2-wire PLC Loop Power)
- Choice of multiple CPU-based control functions
- Availability of optional modules to accommodate particular needs :
 - PCB design in time of a power failure
 - Number of control signals can be increased to 5 relays per board
 - Number of electrodes can be chosen 8~16 for continuous level
- Choice of High-Pressure or Low-Pressure electrodes depending on local needs
- Availability of High-Pressure or Low-Pressure water columns
- Simple installation and set-up, and easy maintenance
- Tensands of similar electrodes are already in use worldwide.

System Components

- Electrodes : selectable between 8 to 16
 - High temperature/pressure (SHE-56) : 560°C/300Bar
 - Low temperature/pressure (SLE-26) : 260°C/50Bar
- Local display and alarm control units (SDG-3000 for continuous systems and SDS-3000 for switching system)
- Remote display units (SRD-64 continuous system/panel mount)
- Water columns, manifolds and inserts for electrodes
 - For high temperature/pressure up to 560°C/300Bar : HPC-3056
 - For low temperature/pressure up to 370°C/210Bar : HPC-2137
- Connecting cables for high temperature applications

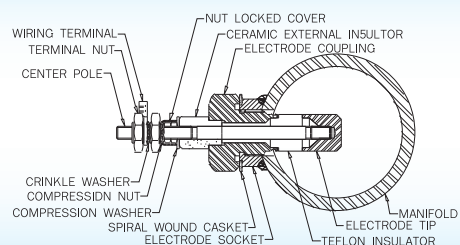

* Modern boilers provide clean dry steam. Incorrect water level in the drum must be detected :

Too high a level can lead to turbine blade erosion by wet steam, and too low a level can cause explosion due to the boiler tube overheating. Therefore, indication of water level in steam generating plant and drum level indication in the control room are required law by in every country.

Operating Principle

Two columns of off-set electrodes are installed along the opposing sides of a water column, which is usually installed to the boiler such that one half of the electrodes are above the normal water level.

The water column is connected between steam and water pipes which are attached to the boiler. If desired, the water column may be isolated from the boiler by valves so that installation of electrodes or maintenance work can be performed without shutting down the operation.

Electrodes from each side of the two columns are connected to one electronics unit by separate cables. Two conductors are connected to each electrode, one for signal drive and the other for return signal. A low-frequency square wave is used to drive the electrodes through drive resistors. Input boards, each powered by its own power supply (AC or DC), measure the signal from each electrode and feed alternate segments of the display. This arrangement assures redundancy against failure in any part of the system. Depending on 5 relay installed can be used to operate trips, audible, visual or other alarm indications.

Each relay can be set to operate at any water level. For example, alarm could be set to give outputs on high-high, high, low and low-low levels, with trips on the high-high and low-low levels.

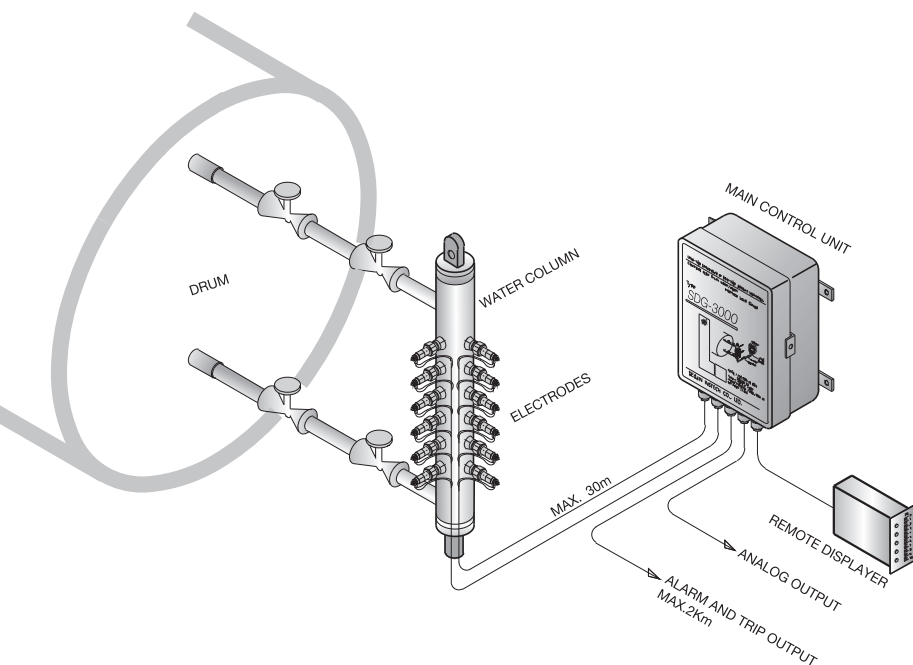

The electronics unit performs a resistance measurement between the insulated tip of each electrode and the wall of the water column. The resistance measured in water is significantly less than that measured in steam. The presence or absence of water is determined at each point, and the level of water is indicated. If no signal is returned, or a very low amplitude signal is returned, it is an indication of either a short circuit or a broken wire. Thus, faulty conditions are also indicated on the display. The levels indicated in the control room can also be duplicated on remote display units. All other functions, including fault indications, of the main display unit are duplicated on up to six remote display units.

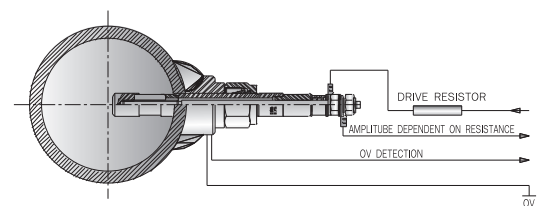

Water columns are designed and fabricated to the same level of reliability as that has been built into the electrodes and the rest of the system. For example, the columns are designed to withstand 150% of the rated high pressure of 300 Bar, and their hydraulic integrity are tested through approved NDT methods and Hydrostatic tests. In addition, all materials and fittings used are selected to comply with ASME Boiler and Pressure Vessel and ASME B31.1 Power Piping Codes. CMTR/WPS/PQR documentation will be provided to the customer if requested.

Seojin Instech is a member of ASME, Korea Electric Power Institute Code (KEPIC), and is a registered organization for fabrication of Q-Class equipment for nuclear and fossil electric power plants, and is also recognized as an Outstanding Venture Company by Korea Electric Power Company (KEPCO).

Electrode Status	Received(at 300 °C) (Resistance -KΩ/Dielectric -μS/cm)	
Steam		High Resistance (More than 10,000 / Less than 0.01)
Water		Low Resistance (15~40/6~9)
Fault		Very Low Resistance (Less than 1 / More than 50)

SDG - 3000 Series

Remote Drum Level Indicator (RDLI)

Outstanding Features

- Can issue and display alarms for a broken wire, leaky electrode or material build-up on electrodes.
- Uses Micro processor based CPU.
- Output signals are compatible with the various controller such as PLC's : Analog, Isolated analog and PLC loop power supply.
- Relay output : Dry contact relay. (SPDT × 5 Max.)
- Dual alarm and display system : 2 rows × 16 LED(10×10mm red/green bar graph) 0 ~100%
Indicating FND Digital meter, and relay outputs for alarm lamps and local buzzers.

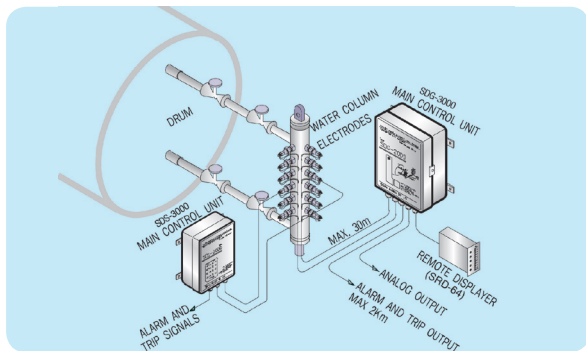

For Ultimate Protection SDG-3000 and SDS-3000 can be Combined in a Single column



System Specifications

▶ Control Unit (MODEL: SDG-3000 Series)

- Power : 90 ~ 240VAC. 60Hz(50Hz : Optional) Max. 60VA max.
20 ~ 36VDC Loop. Negative ground or isolated.
- Ambient Temperature : -20°C ~ 60°C(-4°F ~ 140°F)
- Water/steam interface conductivity :
0.6~1.6μS/cm depending on purity.
- Number of electrodes : 8~16piece.
- Electrode cable length : 5, 10, 20m (30m Max.)
- Local displays :
Level indication : 10 ×10mm. 2Rows×16red/green LED Bar graph, and 20mm(H)×3 Digit FND digital meter for % indication.
Steam = Red LED ; Water = Green LED
Amber = Abnormal operation - Separated wire, Impure material.
Blinking amber LED = Leaky electrode.
- Output
Analog output : 4 ~ 20mA / 0 ~ 20mA. 600Ω or 20 ~ 4mA / 20~0mA (Isolation loop power supply type)
Relay output : 5 SPDT relays.
AC contact rating : 250V.8A.1500VA
DC contact rating : 125V.8A 240W
- Enclosure : 304, 316SS Metal case, 4 Point wall mount.
Size 380(H)×260(W)×120(D)
IP65. NEMA 4X. Net weight 7.2Kg

▶ Remote Display Unit (MODEL: SRD-64)

- Power Supply : Loop power is supplied by Control unit SDG-2000
Local power : 20 ~ 36VDC. 240mA.
- Extension units : Max. of 6 if power is locally supplied.
- Remote display : 6×6mm. 16×2rows (R/G LED Bar graph)
- Remote indication : Fault display for impurity, broken wire, leaky electrode
- Enclosure : Panel mount type 144(H)×72(W)×142(D)
Panel cutout : 137(H)×67(W)

▶ Water Columns(Chamber)

Applicable Design and Material Codes : ASME 31.1 Power Piping Code

■ For high temperature / pressure applications (MODEL: HPC-3056)

- Material : 2" Sch.160 A106B/316SS
- Application pressure limit : 300 Bar(306kg/cm²/4350psi)
- Design pressure : 450 Bar(459kg/cm²/6525psi)
- Temperature : 560°C(1040°F)
- Electrode : SHE-56

■ For Low temperature / pressure applications (MODEL:LPC-2137)

- Material : 2" Sch.160 A106B/316SS
- Application pressure limit : 210 Bar(214kg/cm²/3045psi)
- Design pressure : 310 Bar(316kg/cm²/4495psi)
- Temperature : 370°C(696°F)
- Electrode : SHE-56



Electrode for High Temperature and pressure



Electrode for Low Temperature and Pressure

► Electrodes

(SDG-3000 for Level Sensing and SDS-3000 for Switching)

■ Model SLE-26 for Low Temperature and Pressure Applications

- Pressure : 50 Bar(50.5Kg/cm²/725psi)
- Temperature : 260°C(500°F)
- Insulator material : PTFE
- Electrode material : 316SS and special alloy
- Fittings : Screw mount, M18×1.5 / Metal gasket.
- Design and test pressure : 100 Bar(101Kg/cm²/2175psi)
- Water column used : LPC-2137

■ Model SHE-56 for High Temperature and Pressure Applications

- Pressure : 300 Bar(306Kg/cm²/4350psi)
- Temperature : 560°C(1040°F)
- Insulator material : High purity alumina
- Electrode material : 316SS and special alloy
- Fittings : 22mm A/F nut, 3/4"x20 UNEF Hy-Lok
- Design and test pressure : 450 Bar(459Kg/cm²/6525psi)
- Water column used : HPC-3056

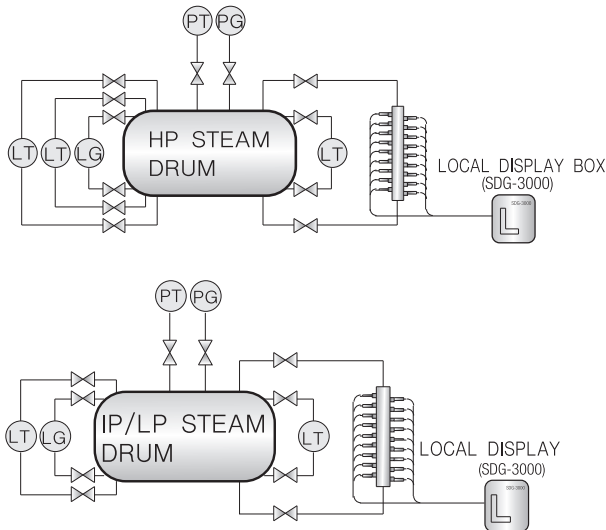

Application Examples

(A Fossil power plant & a Combined-Cycle power plant)

■ Steam/water interface gauging system for high pressure drum

- Level Transmitter - 3sets
- Level Gauge - 1 set
- Level Switch - 2 sets
- Drum Level Gauge - 1 set

■ Steam/water interface gauging system for intermediate and low pressure drum

- Level Transmitter - 3sets
- Level Gauge - 1 set
- Drum Level Gauge - 1 set

Reduction of Density Error

(Preparation for installation of a water column)

The water column and the connecting pipes generally are well insulated, but the insulation is not sufficient to keep the water in the water column as hot as that inside the drum. Density of the cooler water in the water column is denser than that in the drum, and therefore the water level in the water column is lower than that inside the drum. This phenomenon, known as the Density Error, could induce as much as 150mm of measurement error in some cases.

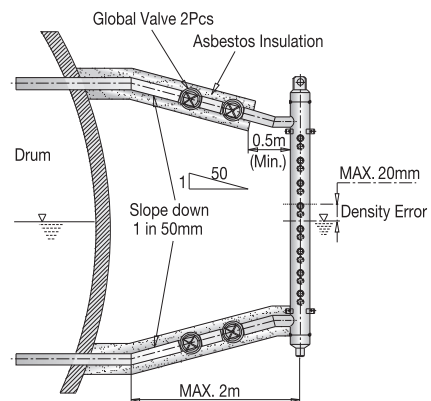

However, the error can be limited to about 20mm by deliberately exposing a part of the hot leg pipe close to the water column as illustrated in the figure. The steam inside the exposed portion of the pipe cools and condenses, releasing the latent heat of condensation to the water. This results in raising the temperature of water in the water column appreciably higher compared to the water without the exposed section, thereby reducing the density error. For this method to be effective the connecting pipes must be installed with proper inclinations and insulated as shown in the figure. In cases where the height of the water column exceeds 1m, water column itself may have to be thermally insulated.

Ordering Informations

Remote Drum Level Indicator (RDLI)

SDG-3000 A 1 A 1 A 5 A 1

DRAIN VALVE

1 = Yes.
2 = N.A

REMOTE DISPLAY(SRD-64)

N = None
A ~ F = 1~ 6 Unit

SPECIAL ELECTRODE CABLE

5, 10, 20, 30m(Max.)

WATER COLUMN MATERIAL

A = SA106
B = SA312 TP316
C = SA335 P11
D = SA335 P12
E = SA335 P22
F = SA335 P91

WATER COLUMN TYPE

1 = HPC-3056 (300Bar. 560°C)
2 = LPC-2137 (210Bar. 370°C)

ELECTRODES TYPE

A = SHE-56 : High Temp. & High Pressure type (300Bar. 560°C. Ceramic)
B = SLE-26 : Low Temp. & Low Pressure type (50Bar. 260°C. PTFE)

RELAY OUTPUT

0 = None (Analog Output Only)
1 = 5 SPDT Relay Output

MODEL SELECTION

A = Electrodes 8Pcs System
B = Electrodes 12 Pcs System
C = Electrodes 16 Pcs System

■ When placing an order, selected ordering number should be indicated on the purchase order sheet.

SDS - 3000 Series

Remote Drum Level Switch (RDLS)

Outstanding Features

- Can issue and display alarms for a broken wire, leaky electrode or material build-up on electrodes.
- Uses Micro processor based CPU
- Output signals are compatible with the various controllers such as PLC's :
 - Analog, isolated analog, and PLC loop power supply.
 - Relay output : Dry contact relay.
- Various combination of electrodes :
 - 1 Electrode : Single channel ON/OFF type
 - 2 Electrode : 1 or 2 Channel ON/OFF type

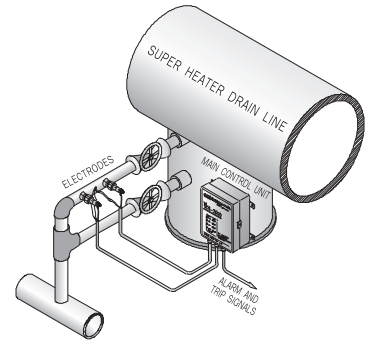

■ When used as Steam Normal - High level alarm

- Prevention of turbine moisture absorption
- Steam drain line adjustment
- Protection of boiler high water level
- Motor coil cooler

■ When used as water normal - Low level alarm

- Protection of boiler feed water low level
- Protection of deaerator low level

System Specifications

▶ Control Unit (MODEL: SDS-3000 Series)

- Power : 90~240VAC. 60Hz(50Hz : Optional). 2×10VA Max.
20~60VDC Loop negative ground or isolated.
- Ambient Temperature and humidity :
-20°C ~ 60°C (-4°F ~ 140°F) / 100%RH
- Water/steam interface conductivity :
0.6 ~ 1.6μS/cm depending on purity
- Number of electrode : 1 ~ 2 (1 or 2 Channels)
- Electrode cable length : 5m, 10m, 20m (Max. 30m)
- Local displays :
Level indication : Steam = Red LED / Water = Green LED
Abnormal operation : Blinking Amber LED = leaky electrode, separated wire, impure material

• Output : Relay output :

- Steam/Water Status relay : 1a4c × 2
- Abnormal alarm fault relay : 1C SPDT
- AC contact rating : 250V,5A 1500VA
- DC contact rating : 125V,5A 240W(Option)

• Enclosure : 304SS, 316SS metal case, 4 Point wall mount.

- Size 380(H)×260(W)×120(D)
- IP65. NEMA4X. Net weight 7.2Kg

Application Examples

(Fossil Power and Combined-Cycle Power Plants)

▶ 1 Superheater, 2 Drain Line (Steam / Water Detection)

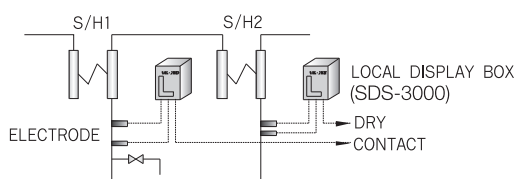

▶ 1 Reheater, 2 Drain Line (Steam / Water Detection)

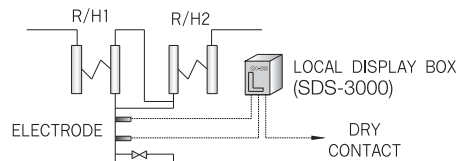

► **High Pressure chamber**
(MODEL : SM-3056)

- Style : Side Arm(Vertical) and In Line(Horizontal)
- Material : 2" Sch.160 A106B / 316SS
- Pressure : 300 Bar(306Kg/cm²/4350psi)
- Temperature : 560°C(1040°F)
- Electrode : SHE-56, SLE-26

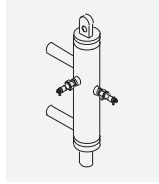

► **Low Pressure chamber**
(MODEL : SLC-1234)

- Style : Side Arm(Vertical) and In Line(Horizontal)
- Material : 2" Sch.160 A106B / 316SS
- Application Pressure limit : 120 Bar(122Kg/cm²/1740psi)
- Design pressure : 180 Bar (261psi)
- Temperature : 340°C(643°F)
- Electrode : SHE-56, SLE-26

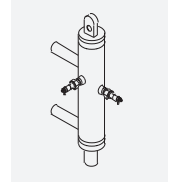

► **Direct Insert Welding Kit**
(MODEL : SIW-3056)

- Material : 316SS
- Pressure : 300 Bar(306Kg/cm²/4350psi)
- Temperature : 560°C(1040°F)
- Electrode : SHE-56, SLE-26

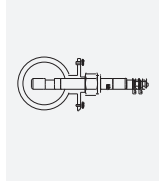

► **Flange Mount**
(MODEL : SDF-1234)

- Material : 316SS (JIS & ANSI Flange)
- Pressure : 120 Bar (122Kg/cm²/1740psi)
- Temperature : 340°C(643°F)
- Electrode : SHE-56, SLE-26

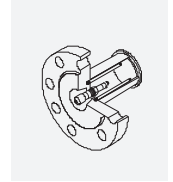

Ordering Informations

■ **Remote Drum Level Switch (RDLS)**

SDS-3000 A 1 1 H 1 A 5

ELECTRODE CABLE
5, 10, 20, 30m(Max.)

MOUNTING PARTS MATERIAL

A = SA106
B = SA312 TP304
C = SA312 TP316
D = SA335 P11
E = SA335 P22
F = SA335 P91

WATER COLUMN TYPE

1 = Side Arm(Vertical) type
2 = In Line(Horizontal) type

ELECTRODES CHAMBER TYPE

H = Chamber Type SM-3056 (300Bar, 560°C)
L = Chamber Type SM-1234 (120Bar, 340°C)
W = Direct Inset Welding Kits type SIW-3056 (300Bar, 560°C) 316SS
F = Direct Flange Mount type SDF-1234 (120Bar, 340°C) 316SS

ELECTRODES QUANTITY

1 ~ 2 PCS

ELECTRODES TYPE

1 = SHE-56 : High Temp. & High Pressure type (300Bar, 560°C, Ceramic)
2 = SLE-56 : Low Temp. & Low Pressure type (50Bar, 260°C, PTFE)

MODEL SELECTION

A = 1 ~ 2 Electrodes (General type)

■ When placing an order, selected ordering number should be indicated on the purchase order sheet.

 **SeoJin Instech Co., Ltd.**

12, Sagimakgol-ro 148beon-gil, Jungwon-gu,
Seongnam-si, Gyeonggi-do, 462-807, Korea
☎ +82-31-627-9000 📠 +82-31-624-5345
<http://www.seojin.biz>

Printed by Daoom. 2010. 04 20-CG-003. Rev: 1

■ Specifications subject to change without notice