



DIGITAL INVERTER PROPANE GENERATOR



PS1000i **OWNERS MANUAL**

Product Support Product Information, Application, Servicing & Warranty Questions

Please email us at info@alpgenerators.com
or call (833) 398-4433 Monday – Friday 9:00 am – 5:00 pm (PST)

TABLE OF CONTENTS

TABLE OF CONTENTS	2
FEATURES	3
SAFETY INFORMATION	4 - 6
COMPONENT IDENTIFICATION	7 - 9
PREPARING THE GENERATOR	9 - 10
STARTING THE GENERATOR	11
USING THE GENERATOR	11 - 14
MAINTENANCE	
Service Schedule	14 - 15
Changing the Oil	15
Spark Plug Maintenance	16
Air Filter Maintenance	17
Storage and Transportation	17 - 18
TROUBLESHOOTING	19
SERVICE INFORMATION	
Generator Specifications	20
Wiring Diagram	21

FEATURES

- 100% Propane Powered Generator.
- Runs on both 1 lb and 20 lb propane tanks.
- 60 Hour Run Time on 20 lb Tank.
- 3 Hour Run Time on 1 lb Tank.
- Gasoline Free Operation.
- Full Power Panel with Engine Shutoff Switch, Circuit Breaker, and Power Outlets.
- 2x Power With Parallel Ports.
- (2) Fully Protected 120V Outlets.
- Can Run Most Refrigerators
- Ultra Bright Emergency LED Light.
- 52 dBA Super Quiet Operation.
- 30 lb Portable, Lightweight Design.
- Handle for Easy Transporting.
- EPA & CARB Approved.

This manual provides information regarding the operation and maintenance of these products. We have made every effort to ensure the accuracy of the information in this manual. We reserve the right to change this product at any time without prior notice.

Notice Regarding Emissions

Engines that are certified to comply with U.S. EPA emission regulations for SORE (Small off Road Equipment), are certified to operate on regular unleaded gasoline and may include the following emission control systems: (EM) Engine Modifications and (TWC) Three-Way Catalyst (if so equipped).

GENERAL SAFETY PROCEDURES

If the generator is operated according to the operating manual, it can be safely and reliably operated.

Before operating the generator, please read and understand this manual carefully; otherwise, it may cause personal injury or equipment damage.

Please familiarize yourself with the following safety symbols and words:

The safety alert symbol is used with one of the safety words (**DANGER**, **CAUTION**, or **WARNING**) to alert you of hazards. Please pay attention to these hazard notices both in this manual and on the generator.

DANGER: Indicates a hazard that will result in severe injury or death if instructions are not followed.

WARNING: Indicates a strong possibility of causing severe injury or death if instructions are not followed.

CAUTION: Indicates a possibility of personal injury or equipment damage if instructions are not followed.

-  **DANGER:** This generator produces poisonous carbon monoxide gas when running. This gas is both odorless and colorless. Even if you do not see or smell gas, carbon monoxide may still be present. Breathing this poison can lead to headaches, dizziness, drowsiness, and, eventually, death.
- Use **ONLY** in well-ventilated areas.
 - Keep several feet of clearance on all sides to allow proper ventilation of the generator.

-  **WARNING:** The exhaust from this product contains chemicals known to the State of California to cause cancer, birth defects, or other reproductive harm.

-  **WARNING:** This generator may emit highly flammable and explosive vapors, which can cause severe burns or even death. A nearby open flame can lead to an explosion even if not directly in contact with propane.
- Do not operate near an open flame.
 - Do not smoke near the generator.
 - Always operate in a well-ventilated area.
 - Always operate on a firm, level surface.
 - The generator exhaust system is very hot during operation and immediately after shutting down. To prevent burns, please pay attention to the warning label on the generator.
 - The muffler is still hot after the generator is turned off. Be careful not to touch it. Wait for the generator to cool off before transportation or storage.
 - Disconnect the propane tank before storing or transporting the generator.

GENERAL SAFETY PROCEDURES (Continued)

- ⚠ WARNING:** The exhaust from this product contains chemicals known to the State of California to cause cancer, birth defects, or other reproductive harm.
- Generator should only be plugged into electrical devices, either directly or with an extension cord. NEVER connect to a building electrical system without a qualified electrician. Such connections must comply with local electrical laws and codes. Failure to comply can create a backflow of power, which may result in severe injury or death to utility workers.
 - Do not use uncovered in rainy or wet conditions.
 - Do not touch bare wires or receptacles (outlets).
 - Do not allow children or non-qualified persons to operate.
- ⚠ WARNING:** As a backup power source for buildings, the connection of the generator to its electrical system must be operated by a professional electrician, and the corresponding legal and electrical regulations must be observed. Otherwise, the generator's current may be fed back to the public circuit. In this way, if the electricity company's employees or others are exposed to the electric wires during the transmission, they will be electrocuted; at the same time, the generator may explode, burn or cause the building's electrical equipment to catch fire due to the impact of commercial power.
- ⚠ WARNING:** This generator produces heat when running. Temperatures near exhaust can exceed 150°F (65°C).
- Do not touch hot surfaces. Pay attention to warning labels on the generator denoting hot parts of the machine.
 - Allow generator to cool several minutes after use before touching engine or areas which heat during use.
- ⚠ CAUTION:** Misuse of this generator can damage it or shorten its life.
- Use the generator only for its intended purposes.
 - Operate only on dry, level surfaces.
 - Allow generator to run for 3 - 5 minutes before connecting any electrical devices.
 - Shut off and disconnect any malfunctioning devices from the generator.
 - Do not exceed the Wattage capacity of the generator by plugging in more electrical devices than the unit can handle.

GENERAL SAFETY PROCEDURES (Continued)

In addition to the above safety notices, please familiarize yourself with the safety and hazard markings on the generator.

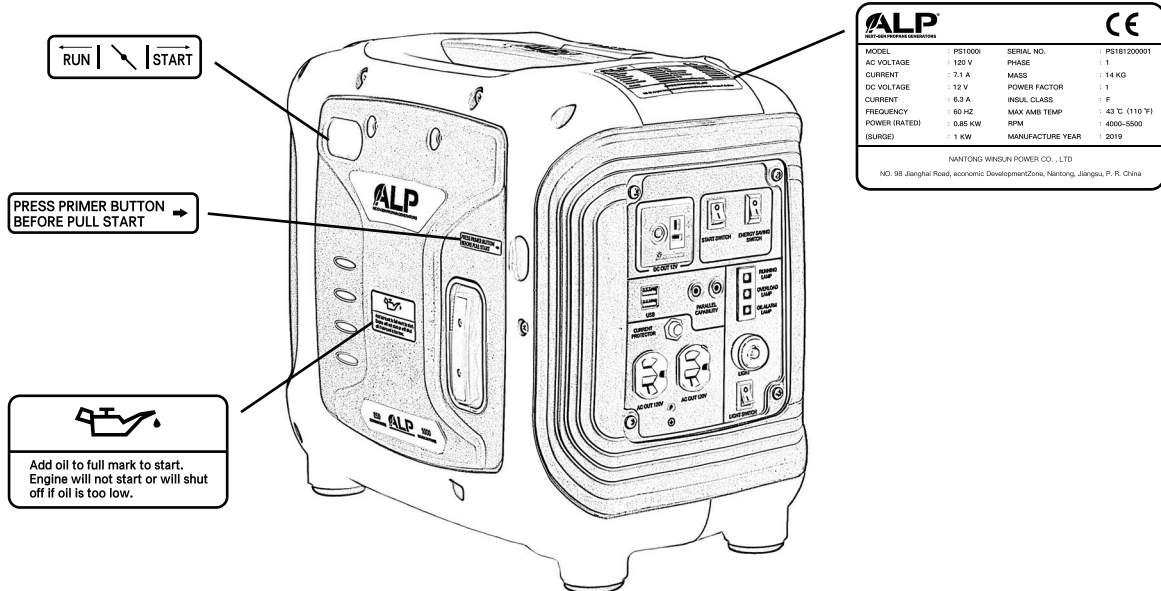

⚠ DANGER

- Risk of fire. Keep all objects at least 3 feet away from this machine. Heat from muffler and exhaust gases can ignite combustible objects.
- Exhaust contains poisonous carbon monoxide gas that can cause unconsciousness or DEATH. Operate in well ventilated, outdoor areas away from open windows or doors.
- Do not expose to rain or use in damp locations.
- Generator is a potential source of electric shock. Do not expose to moisture, rain or snow. Do not operate with wet hands or feet.
- Possibility of PERSONAL INJURY or LOSS OF LIFE if Operator's Manual instructions are not followed.
- Risk of fire. Never disconnect the propane cylinder when unit is running.

PRIOR TO START CHECK OIL LEVELS.	↑ Store unit in upright position to prevent oil leakage.
⚠ READ OPERATOR'S MANUAL BEFORE USING THIS PRODUCT.	⚠ OPERATION CONTROL INFORMATION PLEASE READ OWNER'S MANUAL BEFORE OPERATION. THIS ENGINE MEETS THE EPA Tier 3 & 2015 CALIFORNIA CAR AND OFF-DIEMER EMISSIONS REQUIREMENTS. THIS ENGINE IS CERTIFIED TO OPERATE ON LPG. FOR THE FULL LIST OF THE MODEL'S CERTIFICATIONS, PLEASE REFER TO THE OWNER'S MANUAL. NOTE: THE OWNER OF THE AIR INTAKE, THE USER INSTRUCTIONS THIS ENGINE IS EXPOSED TO THE DANGER OF CARBON MONOXIDE AND FIRE. ALWAYS OPERATE THIS ENGINE IN WELL-VENTILATED AREAS. ALWAYS OPERATE THIS ENGINE OUTDOORS. FORM 0119 / P. 1 / 10 / 12 / 13 / 14 / 15 / 16 / 17 / 18 / 19 / 20 / 21 / 22 / 23 / 24 / 25 / 26 / 27 / 28 / 29 / 30 / 31 / 32 / 33 / 34 / 35 / 36 / 37 / 38 / 39 / 40 / 41 / 42 / 43 / 44 / 45 / 46 / 47 / 48 / 49 / 50 / 51 / 52 / 53 / 54 / 55 / 56 / 57 / 58 / 59 / 60 / 61 / 62 / 63 / 64 / 65 / 66 / 67 / 68 / 69 / 70 / 71 / 72 / 73 / 74 / 75 / 76 / 77 / 78 / 79 / 80 / 81 / 82 / 83 / 84 / 85 / 86 / 87 / 88 / 89 / 90 / 91 / 92 / 93 / 94 / 95 / 96 / 97 / 98 / 99 / 100

⚠ DANGER

Flammable gas under pressure. Leaking propane gas may cause fire or explosion if ignited. Contact propane gas supplier for repairs or disposal of cylinder or unused propane gas. Do not store cylinder in a building, garage or enclosed area. Failure to follow these instructions could result in fire causing DEATH or SERIOUS INJURY.

⚠ WARNING

Do not store a spare propane gas cylinder under or near this generator.
Do not allow the propane gas tank to tip or turn over.

⚠ Equipped for use with propane (LPG)

The operator's manual contains important information regarding the safe use and assembly of this generator. Read and follow all warnings and instructions. For Outdoors Use Only. If stored indoors, install and use propane cylinder outdoors. Remove propane cylinder when generator is not in use.

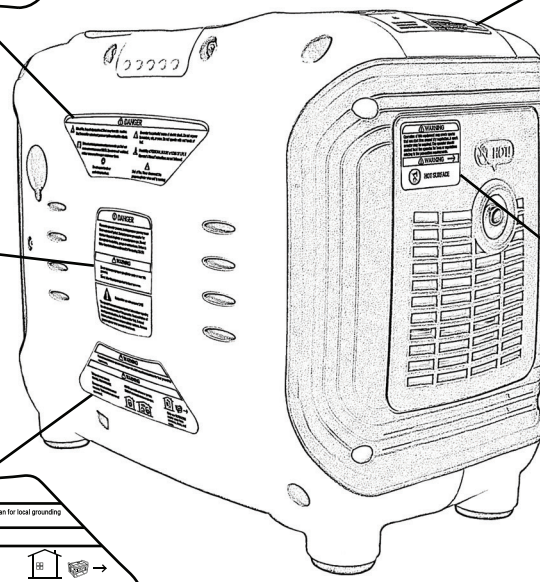

⚠ WARNING

Operation of this equipment may create sparks that can start fires around dry vegetation. A spark arrestor may be required. The operator should contact local fire agencies for laws or regulations relating to fire prevention requirements.

⚠ WARNING →

⚠ **HOT SURFACE**

⚠ WARNING

Product does not include ground rod or copper wire. Call a qualified electrician for local grounding requirements.

⚠ WARNING

Using a generator indoors CAN KILL YOU IN MINUTES. Generator exhaust contains carbon monoxide. This is a poison you cannot see or smell.

NEVER use inside a home or garage, EVEN IF doors and windows are open.

Only use OUTDOORS and far away from windows, doors, and vents.

GENERATOR COMPONENTS

Please familiarize yourself with the locations and functions of the various components and controls of your generator.

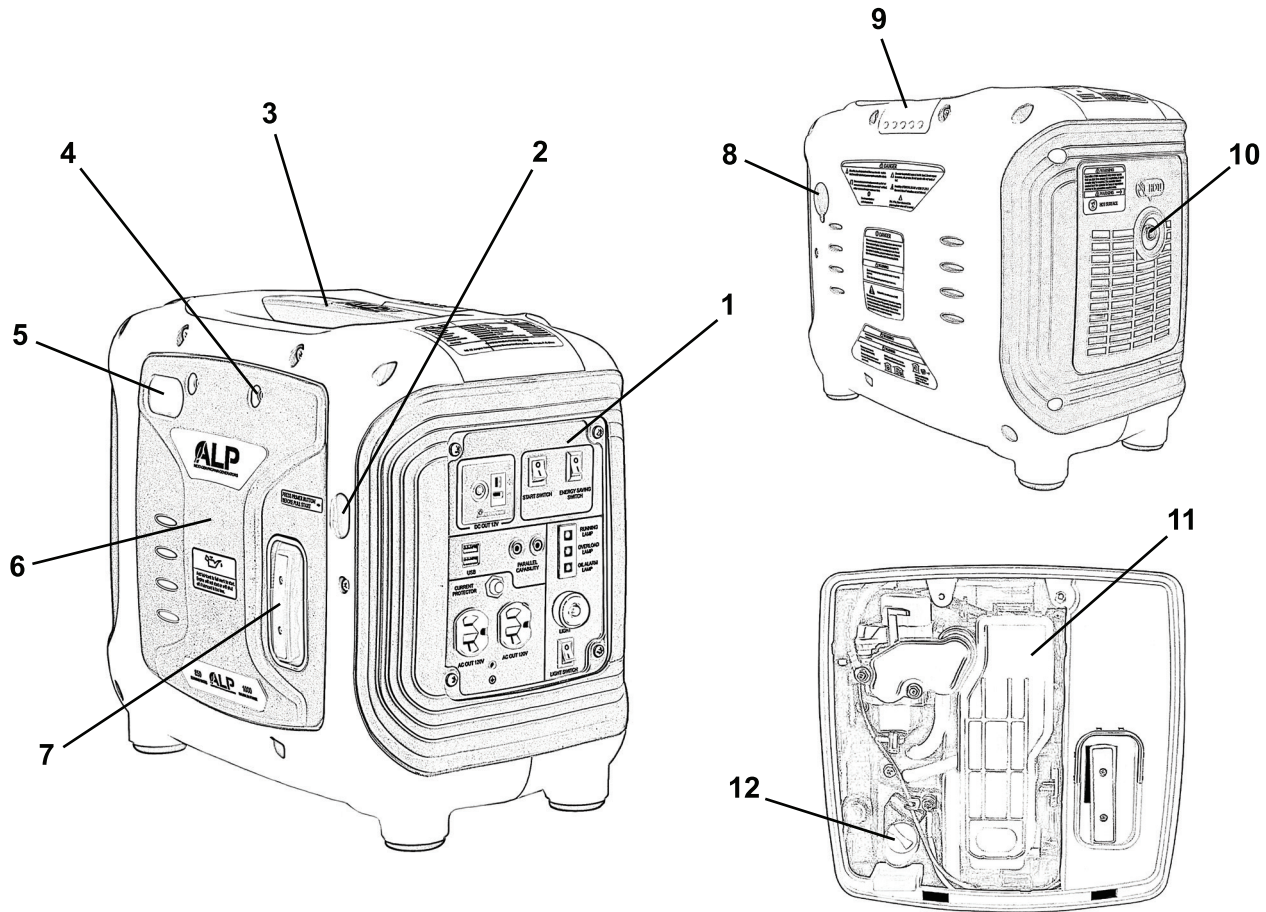

1. **Control Panel** - Contains the main controls for the generator.
2. **Primer Button** - A button that is pressed in order to “prime” the engine before starting
3. **Carrying Handle** - Allows safe carry of the generator.
4. **Maintenance Cover Plate Screws** - Screws that hold on the Maintenance Cover Plate.
5. **Choke Switch** - Allows the airflow into the carburetor to be restricted to assist in starting the engine.
6. **Maintenance Cover Plate** - Remove this plate to maintain the engine components.
7. **Recoil Start** - Easy Pull Recoil Start to start the engine.
8. **Propane Tank Connector** - Connects to propane tank to the generator.
9. **Spark Plug Repair Panel** - Remove panel to repair or replace the spark plug.
10. **Muffler** - Reduces engine emissions and reduces noise.
11. **Air Filter Cover** - Contains a removable, cleanable, oiled, sponge-like element that cleans the air going into the engine.
12. **Oil Filler Cap** - Use to add or check the oil.

GENERATOR COMPONENTS (Continued)

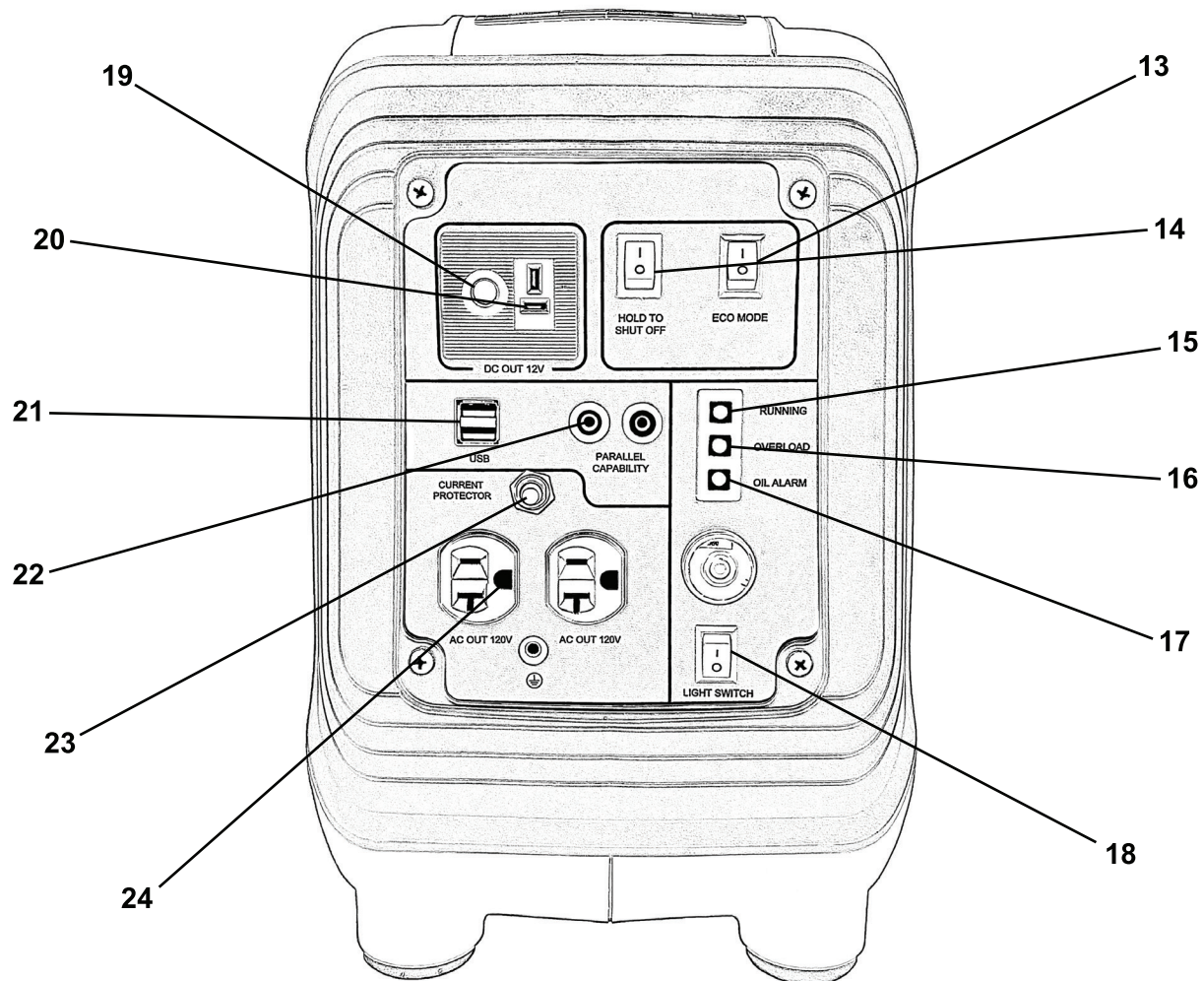

- 13. **ECO Mode Switch** - Used to reduce gas consumption during operation.
- 14. **Engine Switch** - 2 Position Switch to “Start” or turn “Off” the generator.
- 15. **Running Light** - Green LED light indicates the generator is running.
- 16. **Overload Light** - Red LED light indicates the generator is overloaded.
- 17. **Low Oil Light** - Yellow LED indicates low engine oil in generator.
- 18. **LED Emergency Light** - Super bright emergency flash light.
- 19. **DC Circuit Breaker** - Resettable switch that protects the generator from electrical overload.
- 20. **DC Outlet** - DC Output for charging batteries or running small DC powered items.
- 21. **USB Outlet** - Dual 2.0A USB charging ports.
- 22. **Parallel Power Ports** - Combine two generators to increase available wattage.
- 23. **AC Circuit Breaker** - Resettable switch that protects the generator from electrical overload.
- 24. **120V 3-Prong Receptacles** - Use to connect electrical devices that run 120V, 60 Hz, single phase, AC current (NEMA 5-20).

GENERATOR COMPONENTS (Continued)

ECO Mode Switch

When the generator is disconnected from the electrical equipment, the generator set speed is at idle; when the electrical equipment is connected to it, the generator will return to the appropriate speed to provide the power required by the electrical load. This device is used to reduce gas consumption during operation.

- ECO Mode does not run fully when an electrical appliance needs instantaneous power.
- When electrical equipment needs considerable instantaneous power, turn the ECO Mode Switch to OFF.
- When the generator is connected to a high load electrical at the same time, turn the ECO Mode Switch to OFF to reduce the voltage change.
- During DC operation, turn the ECO Mode Switch OFF to obtain a larger current.

PREPARING THE GENERATOR FOR USE

Using the Generator for the First Time

If you are using the generator for the first time, there are a few steps you must take to prepare it for operation.

⚠ WARNING: Check the generator so that it is on a level surface and the engine is off.

Step 1 - Check the oil level

The generator is equipped with an automatic shutoff to protect it from damage due to low oil. Nonetheless, you should check the oil level of the engine before each use to ensure that the engine crankcase has a sufficient amount. Running the generator when the amount of oil is insufficient may severely damage the engine.



Figure 1 - Removing the Maintenance Cover Plate



Figure 2 - Unscrewing the Oil Filler Cap

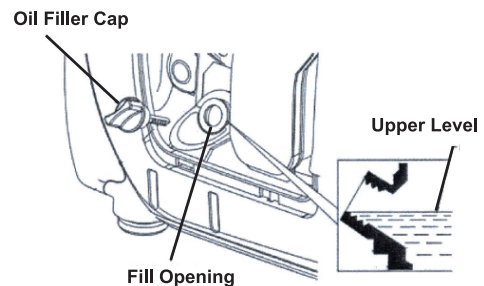

Figure 3 - Adding Oil

To check the oil level:

1. Make sure the generator is on a level surface.
2. Unscrew the service cover screw and open the service cover (see figure 1).

PREPARING THE GENERATOR FOR USE (Continued)

To check the oil level (continued):

3. Remove the Oil Filler Cap (see figure 2).
4. When the generator is placed level, the oil should be filled to the bottom edge of the Fill Opening threads (see figure 3).
5. The use of non-detergent engine oil or 2-stroke engine oil may shorten the life of the engine. We recommend using a strongly decontaminated, high-quality 4-stroke engine oil that meets or exceeds the American Petroleum Institute's SG, SF rating as required by US automakers. Select an oil that is suitable for the average temperature in your area.

Step 2 - Check the air filter

The air filter must be maintained appropriately to ensure the optimal health of your generator. Check the air filter to make sure it is clean and undamaged.



Figure 4 - Removing the air filter cover



Figure 5 - Removing the air filter

To check the air filter:

1. Make sure the generator is on a level surface.
2. Loosen the screws and remove the Maintenance Cover Plate (see figure 1).
3. Press the locking tab at the top of the air filter cover downwards, then remove the air filter cover (see figure 4).
4. Remove the air filter and inspect for damage or debris (see figure 5).
5. If necessary, clean or replace the air filter (see page 17).
6. Reinsert the clean air filter.
7. Reinstall the air filter cover by inserting the bottom and top cleats.
8. Reinstall the Maintenance Cover Plate and screws.

STARTING THE GENERATOR

⚠ WARNING: Before starting the generator, make sure that the correct four-stroke engine oil has been added to the engine. Note: No engine oil is filled at the manufacture.

1. Disconnect all electrical loads from the generator before attempting to start.
2. Ensure that the propane tank valve is on.
3. During cold starts, move the choke switch slightly to the right towards the START position (see figure 1).

After starting to warm up, move the choke switch to the left RUN position (see figure 2).

⚠ WARNING: Do not move the choke switch when the engine is hot or when the temperature is high. Leave the choke switch to the RUN operating position on the left.

4. Pull the starter handle until you feel resistance, then pull the handle in the direction of the arrow (see figure 3). Do not allow starter handle to spring back; slowly return it instead.

⚠ CAUTION: When you start the generator for the first time, you may need to pull the handle a few times. The pressure relief valve will send the gas to the carburetor.

5. After starting the engine, make sure that the choke valve is in the left RUN position.



Figure 1



Figure 2



Figure 3

USING THE GENERATOR

⚠ WARNING

- As a backup power source for buildings, the connection of the generator to its electrical system must be operated by a professional electrician, and the corresponding legal and electrical regulations must be observed. Otherwise, the generator's current may be fed back to the public circuit. In this way, if the electricity company's employees or others are exposed to the electric wires during the transmission, they will be electrocuted; at the same time, the generator may explode, burn or cause the building's electrical equipment to catch fire due to the impact of commercial power.
- Do not exceed the specified sockets' current limit.
- Do not connect the generator to household electrical circuits as it may damage the generator or damage the home appliance.

USING THE GENERATOR (Continued)

- Do not use the generator for purposes beyond its reach. Also, observe the following rules:
 - Do not parallel with generators from other brands.
 - Do not lengthen the exhaust pipe.
- The length of the extension cable is limited: The 16 AWG cable is 20 feet, and the 14 AWG cable is 30 feet.
 - If you need an extended cable, use a flexible rubber cable.
- Keep the generator away from other wires and cables, such as distribution networks.
- When using AC power, a DC outlet can be used. If you want to use both AC and DC outlets at the same time, note that the total power should not exceed the sum of AC and DC power.
- Most devices require higher than calibrated power when starting the motor.

Once you have allowed the engine to run for several minutes, you may connect electrical devices to the generator.

AC Usage

1. Start the generator set and make sure the green running light (15) is lit (may take 3 seconds). Allow the engine to warm up for a few minutes before connecting electrical appliances.
 - ⚠ **CAUTION:** If the green running light is off and the red overload light is on, shut off the generator and restart the engine.
2. Make sure that the electrical equipment is turned off. Then connect the plug to the generator's AC outlet (17).
 - ⚠ **CAUTION:** Make sure the connected device is off before connecting. If it is on, the device will start suddenly and may cause personal injury.
3. If substantial overload causes the Overload Light (16) to remain on, it will damage the generator and shorten its life.
4. Make sure that the equipment is working correctly before connecting an appliance to the generator. If the generator starts to run abnormally, drops speed, or stops suddenly, turn off the generator's power switch immediately, and disconnect the appliance.
 - It is highly recommended to use a plug with a circuit breaker to connect devices to the generator.
 - Check to ensure that the device power does not exceed the maximum rated power of the generator.
5. If necessary, set the ECO Mode Switch to the ON position.

⚠ **CAUTION:** ECO Mode Switch

- If the appliance requires instantaneous power, the ECO mode does not operate effectively.
- When using full-load output, move the ECO Mode Switch to the OFF position to reduce voltage changes.

USING THE GENERATOR (Continued)

CAUTION: Running Light and Overload Light

- Under normal operating conditions, the Running Light will be on. If the generator is overloaded (over 0.85KVA), or if the connected equipment short-circuits, the Running Light will go out, and the Overload Light (red) will light up. At which point, the current connection to the appliance will cut off in 20 seconds.
- If the Overload Light is on, turn off the engine and check the cause of the overload.
- Before connecting the appliance to the generator, first check whether it is in good condition, or whether the power level exceeds the generator. Then connect the cable and start the generator.
- When the motor starts, the Overload Light and Running Light may be on at the same time. If the red light goes out after 4 seconds, it is normal. If the red light is still on, contact the aftersales department of the manufacturer.
- If the connected equipment such as a motor requires a large starting power, the Overload Light and the Running Light may light at the same time for a short time. This is normal. After the equipment starts up, the Overload Light will go out, and the Running Light will still be on.

DC Usage

The DC output should only be used for charging 12V automotive lead-acid batteries. When the battery is charged, disconnect it from the generator.

WARNING

- To prevent sparking at the electrical plug (socket), first, connect the charging cable to the generator and then to the battery. Removal must begin at the battery side.
- Before connecting a charging cable to an installed car battery, disconnect the battery ground cable. Connect the battery ground cable when the charging cable is removed to prevent short circuits or sparks if you inadvertently contact the battery terminals with the car frame.
- The battery evaporates flammable gases. Keep away from sparks and pyrotechnics and provide proper ventilation while charging.
- The battery contains a poisonous sulfuric acid (electrolyte). Contact with skin or eyes can cause burns. Always wear protective clothing and keep away from children. **If on skin:** Rinse immediately with water. **If in eyes:** Flush with water for at least 15 minutes and seek medical attention. **If swallowed:** Drink plenty of water, milk, magnesium oxide, or vegetable oil and seek medical attention.
- When using AC power, a DC outlet can be used. Overloading the DC circuit may trip the DC circuit protector. If this happens, remove the DC load and press the reset button.
- Do not attempt to start a car while the generator is still connected to the battery; otherwise, the generator may be damaged.
- The positive pole of the charging cable is connected to the positive pole of the battery. Do not confuse the positive pole and the negative pole. Otherwise, the generator and the battery will be severely damaged.

USING THE GENERATOR (Continued)

Low Oil Level Alarm System

The Low Oil Level Alarm System is designed to prevent damage to the engine due to insufficient crankcase oil. Before the oil in the crankcase drops to the safety line, the Low Oil Level Alarm System will automatically shut down the engine, and the generator power switch will remain in the ON position.

If the Low Oil Level Alarm System shuts down the engine, and you restart the engine, the Low Oil Light will light up, and the engine will not operate.

If this happens, add oil.

Stopping the Engine

In an emergency:

To stop the engine in an emergency, hold the engine switch in the OFF position for at least 4 seconds or until the generator turns off.

In normal use:

1. Turn off all connected devices and disconnect from the generator.
2. Hold the engine switch in the OFF position for at least 4 seconds or until the generator turns off.
3. Shut off the propane tank valve.

MAINTENANCE AND CARE

The Importance of Maintenance

Proper routine maintenance of your generator is essential for safe, economical, and trouble-free operation. It will also help reduce air pollution.

 **WARNING:** Improper maintenance, or failure to correct a problem before operation, can cause a malfunction in which you can be seriously injured or killed. Always follow the inspection and maintenance recommendations and schedules in this instruction manual.

Maintenance Safety

- Make sure the engine is off before you begin any maintenance or repairs.
- Let the engine and exhaust system cool before touching.
- To reduce the possibility of fire or explosion, be careful when working around propane. Use only a nonflammable solvent to clean parts. Keep cigarettes, sparks, and flames away from all fuel-related parts.

 **CAUTION:** Please use ALP spare parts or replacement parts of the same quality; otherwise, it may damage the generator.

MAINTENANCE AND CARE (Continued)

Maintenance Schedule

Maintenance and adjustment schedules are designed to keep the generator set in top working condition. Please check and maintain according to the schedule in the following table.

SERVICE		REGULAR SERVICE PERIOD					
		BEFORE EACH USE	1 MO. OR 10 HRS.	3 MO. OR 50 HRS.	6 MO. OR 100 HRS.	12 MO. OR 300 HRS.	24 MO.
ENGINE OIL	CHECK	■					
	REPLACE		■		■		
AIR FILTER	CHECK	■					
	CLEAN			*2			
SPARK PLUG	CHECK				■		
VALVE LASH	CHECK					*3	
REDUCING VALVE	CHECK					*3	
GAS CIRCUIT	CHECK	■					
	REPLACE						■

Note:

1. The interval between routine maintenance.
2. Use in a dirty environment, please perform more frequent maintenance.
3. The maintenance mentioned above should be performed by a ProPower authorized maintenance point unless the user has a suitable tool or a mechanical professional.

Changing the Oil

It is only necessary to drain the oil from the crankcase, other than for regular oil changes if it has become contaminated with water or dirt. In this case, you can drain the oil from the generator according to the following steps:

1. Loosen the screws on the front cover and remove the cover (see page 9).
2. Drain all dirty engine oil through the fill opening into an approved oil disposal container.
3. Using a funnel, add the recommended oil to the crankcase (see page 10). When full, the oil level should come close to the top of the oil fill opening (oil capacity: 0.2-0.22L).
4. Replace the front cover plate and tighten the screws.

⚠ ATTENTION: To comply with the requirements of environmental protection, we recommend that you put the used oil in a sealed container and send it to the maintenance or recycling center in your area. Do not dump oil on the ground or in the garbage.

MAINTENANCE AND CARE (Continued)

Spark Plug Maintenance

The spark plug is important for proper engine operation. A good spark plug should be intact, free of deposits, and properly gapped.



Figure 1 - Removing the Spark Plug Repair Panel



Figure 2 - Removing the spark plug cover

To inspect your spark plug:

1. Remove Spark Plug Repair Panel (see figure 1) and spark plug cover (see figure 2).
2. Clean the dirt around the spark plug and unscrew with spark plug sleeve (see figure 3).
3. Visually check the spark plug. If the insulator is cracked or has debris, discard and replace it with a new spark plug. We recommend using an NGK CR7HSA.
4. Measure the spark plug gap with a gauge. The gap should be 0.6-0.7mm, if necessary, carefully bend one end of the electrode to adjust (see figure 4).
5. If you are re-using the spark plug, use a wire brush to clean any dirt from around the spark plug base and then re-gap the spark plug.
6. Install spark plug by hand, being careful not to misalign threads, then tighten 1/2 turn with a wrench and press the washer.
7. Replace the spark plug cover and the Spark Plug Repair Panel.



Figure 3 - Removing the spark plug

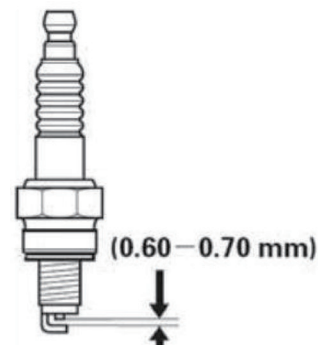

Figure 4

MAINTENANCE AND CARE (Continued)

Air Filter Maintenance

Routine maintenance of the air cleaner helps maintain proper airflow to the carburetor. Occasionally check that the air cleaner is free of excessive dirt. more often.

⚠ CAUTION: Do not operate the machine without an air filter; otherwise, it will cause rapid engine wear.



Figure 5 - Removing the Maintenance Cover Plate



Figure 6 - Removing the air filter cover



Figure 7 - Removing the air filter

To inspect your air filter:

1. Loosen the screws and remove the Maintenance Cover Plate (see figure 5).
2. Press the locking tab at the top of the air filter cover downwards, then remove the air filter cover (see figure 6).
3. Remove the air filter and inspect for damage or debris (see figure 7).
4. Rinse the filter element with a non-flammable solvent and thoroughly dry.
5. Soak the dry air filter in a small amount of engine oil. Ring out any excess oil.
6. Reinsert the clean air filter.
7. Reinstall the air filter cover by inserting the bottom and top cleats.
8. Reinstall the Maintenance Cover Plate and screws.

Storage and Transportation

⚠ CAUTION: Never place any storage cover on the generator while it is still hot.

When transporting your generator:

- Do not run the generator in a vehicle. Remove it first and use it in a ventilated area.
- When transporting the generator, avoid placing it in direct sunlight. If the generator is placed in a sealed cabin, high temperatures in the cabin may cause an explosion.
- Do not transport the generator on rough roads for long periods. If you have to do so, drain the oil before transporting the generator.

MAINTENANCE AND CARE (Continued)

When long-term storing your generator:

- Make sure the storage area is dry and clean.
- Change the oil (see page 15).
- Remove the spark plug (see page 16), pour a tablespoon of clean oil into the cylinder, rotate the engine a few times to distribute evenly, and then reinstall the spark plug.
- Slowly pull the starter handle until pressure is felt. At this point, the piston is rising to the end of its compression stroke. The intake and exhaust valves are closed. In this case, storing the engine helps prevent internal rust.

Troubleshooting		
Problem	Cause	Solution
Engine will not start	Propane hose not screwed in	Screw in hose completely
	Tank is out of propane	Replace with new tank
	Oil is low	Add/Change oil
	Spark plug is dirty	Clean spark plug
	Spark plug is broken	Replace spark plug
	Oil is low	Add/Change oil
Connected device does not start	The running light is off	Start the generator
	The overload light is on	Remove extra devices
No power in DC output	DC circuit fuse is tripped	Press the reset button

Generator Specifications - PS1000i		
AC Rated Wattage	850W	
AC Max Wattage	1000W	
AC Rated Voltage	120V	
AC Rated Frequency	60 Hz	
AC Amperage	7.1A	
DC Voltage	12V	
DC Amperage	6.3A	
Dimensions (mm.)	Length	464
	Width	266
	Height	376
Weight	30.86 lb (14 kg)	
Engine Type	4-Stroke, OHV, Single Cylinder	
Engine Model	PS114	
Ignition System	Crystal Valve	
Displacement	1557cc	
Compression Ratio	7.6:1	
Engine Speed	4800 RPM (ECO switch OFF)	
Cooling System	Air Cooling	
Oil Capacity	7 fl. oz. (0.2L)	
Run Time @ 50%	60 hr. (20 lb tank) / 3 hr. (1 lb tank)	
Noise Level	<52db	

WIRING DIAGRAM

PS1000i

