

Baby Bear Swing Seat

1

Place the four wooden rods in the pockets of the swing.

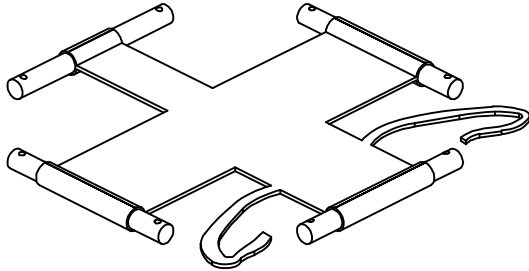

2

Place the front and back rods under the two side rods.

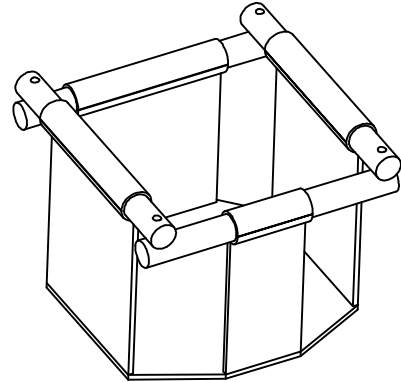

3

Place the rope through the holes in the wooden rods, then make triple knots beneath the rod.

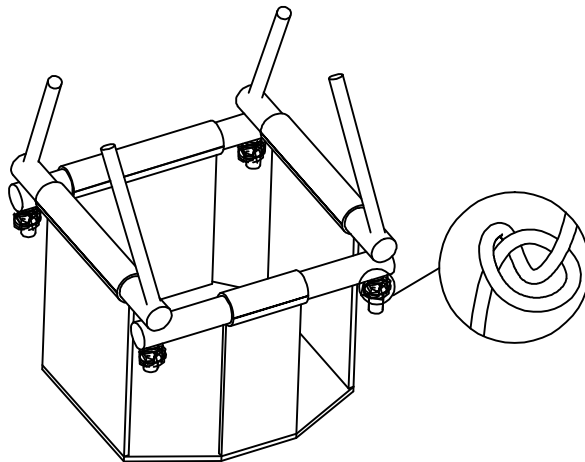

4

Hang the swing to the swing frame. Before using, add weight to the seat and do practice swings to ensure the knots and other pieces are fixed properly.



Warning:

1. Do not let children play alone on the swing. Adult supervision is required at all times.
2. Check the condition of the swing regularly to ensure all parts are tightly secured to avoid failure, injury or hazards.
3. To avoid deterioration of the Swing's parts from weather conditions, store the swing indoors when not in use.

WARRANTY

NEW ZEALAND CONSUMER LAW

Most of our products come with a guarantee or warranty from the manufacturer. Please visit our website to view our full warranty terms and conditions:

<http://forestandfrolic.co.nz/pages/warranty-repairs>

In addition, we are committed to meeting our obligations under the New Zealand Consumer Guarantees Act. You are entitled to seek a repair, replacement, or refund if the goods are faulty, or the service is substandard. Full details of your consumer rights may be found at:

<http://www.consumerprotection.govt.nz>

Please send all warranty and support questions to the following email address:

hello@forestandfrolic.co.nz