

DEZZI

H80

QUICK TURN



BUILT AFRICA TOUGH

Designed and Manufactured in South Africa



**BUILT AFRICA
TOUGH**

H80T HAULER

Axles

Front : Desmond non drive (4x2)
ITL SD 55 Drive (4x4)
Pivoting steering axle

Rear : ITL PD 90

Steering

- Fully hydraulic orbital controlled steering with double acting cylinder
- Full flow filtration
- Working pressure - 1500 Psi (10.3 Mpa)

Tyres

	4x2	4x4
Front :	10.5 x 16" (6 Ply)	11.2 x 24" (6 Ply)
Rear :	18.4 x 34" (6 Ply)	18.4 x 34" (6 Ply)

Electrics

Voltage : 12 Volt
Battery : 1 x 12 Volt sealed type
Alternator : 12 Volt / 95 Amp

Brakes

Type : Inboard wet-sealed disc brakes on rear wheels.
Park Brake : Mechanically applied disc brake at transmission output.

Hitch

- Quickturn
- Weight transfer hitch

Optional Equipment

- Tachograph
- Custom painting
- Stainless steel exhaust

Pneumatic System

Capacity : 20 Litres
Working Pressure : 120 Psi (8.1 Bar) Unloader valve controlled

Engine

Type : JCB
Model : 444TC
Capacity : 4.4 Litres
Power : 75kW @ 2200 RPM
Torque : 425Nm @ 1300 RPM

Hydraulic System

Oil Capacity : 60 Litres
Pumps : Fixed displacement gear driven
Working Pressure : 2400 Psi (16.5 Mpa) Full flow filtration

Operators Compartment (Standard)

- Operator seat - fully adjustable, weight compensating with built-in suspension
- Seat belt

Transmission

Type : ITL
Model : PS 720
Gearing : Constant mesh, full power shift with modulation
Gears : Forward - 4
Reverse - 4
Speed : 40Km/H
Torque Converter : Single phase 3 element, multi-phase.

Service Capacities

Cooling system : 32 Litres (50% Anti-freeze)
Engine Crankcase : 16 Litres
Rear Axle Differential : 16 Litres
Transmission : 15 Litres
Diesel Tank : 135 Litres
Hydraulic System : 60 Litres
Planetary : 2,5 Litres each end

Operational Weights

T - 3920kg V - 10000kg D/T - 18000kg

7MS QUICK TURN WEIGHT TRANSFER DEZZI DUMPER

Tipping System

2 x Double Acting Cylinders. Tipping angle - 60 degrees

Brakes

- S-Cam Air brake
- 16.5" x 7" Drum Brake
- Spring applied, Air released failsafe system

Axle

Rigid solid beam axle

Tyres

14.00 x 24" (20 Ply)

Payload

Payload : 10000kg
Capacity : Struck = 6.7m³ SAE 2:1 = 8.2m³ SAE 1:1 = 9.7m³

TRACTOR / TRAILER SPECIFICATIONS

Weights

Unladen

Front Axle : 1820kg Rear Axle : 3180kg Trailer Axle : 3200kg

Laden

Front Axle : 1900kg Rear Axle : 5300kg Trailer Axle : 11000kg
Payload : 10000kg

- Turning Radius : 5m
- Turning Angle : 90 Degrees
- Trailer Oscillation Angle : 20 Degrees on either side

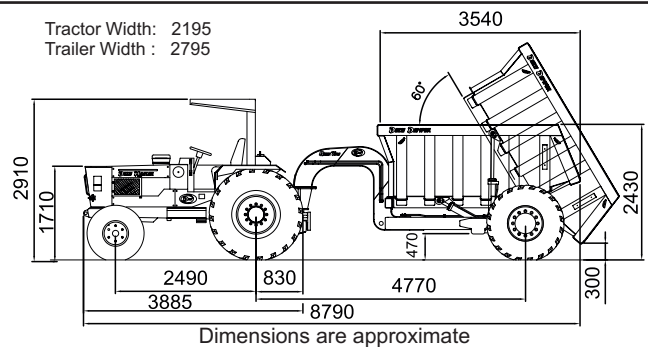

**DESMOND
EQUIPMENT**

Desmond Equipment S.A. reserves the right to modify specifications without notice.

PORT SHEPSTONE HEAD OFFICE

Tel: 039 685 4100 | Fax: 039 685 4476 | E-mail: dezzi@venturenet.co.za
PO Box 111 Port Shepstone 4240, South Africa
Web: www.dezzi.co.za