



# DEZZI H80T RIGID HAULER TRACTOR

4X4 | 4X2



**BUILT AFRICA TOUGH**

Designed & Manufactured in South Africa

[www.dezzi.co.za](http://www.dezzi.co.za)



# DEZZI H80T RIGID HAULER TRACTOR

## SPECIFICATION SHEET

\*Desmond Equipment SA (Pty) Ltd reserves the right to modify specifications without notice.

### ENGINE

TYPE :	JCB	JCB
MODEL :	444 TCI	444 TCI
CAPACITY :	4.4 Liters	4.4 Liters
POWER :	93Kw @ 2200RPM	75Kw @ 2200RPM
TORQUE :	525Nm @ 1300RPM	425Nm @ 1300RPM

### TRANSMISSION

TYPE :	ITL
MODEL :	PS 750 / 1000
GEARING :	Constant mesh, full power shift with modulation
GEARS :	Forward - 4 / 6 Reverse - 1
SPEED :	40Km/H
TORQUE CONVERTER :	Single phase 3 element, multi-phase

### AXLES

	4x2	4x4
FRONT :	Dezzi non-drive Pivoting steering axle	ITL SD 55 Drive Pivoting steering axle
REAR :	Rockwell 485	Rockwell 485

### TYRES

	4x2	4x4	Forestry Logger
FRONT :	10.5 x 16	380 R24	14.9 x 24
REAR :	20.8 R38	480 R34	18.4 x 34

### BRAKES

TYPE :	S-Cam Air Brake 16.5" x 5" Drum Brake
PARK BRAKE :	Spring applied with emergency failsafe

### STEERING

- Fully hydraulic orbital controlled steering with double-acting cylinder
- Full flow filtration
- Working pressure - 1500 Psi (10.3 Mpa)

### ELECTRICS

VOLTAGE :	12 Volt
BATTERY :	1 x 12 Volt sealed type
ALTERNATOR :	12 Volt / 95 Amp

### PNEUMATIC SYSTEM

CAPACITY :	20 Litres
WORKING PRESSURE :	120 Psi (8.1 Bar) Unloader valve controlled

### HYDRAULIC SYSTEM

OIL CAPACITY :	80 Liters
PUMPS :	Fixed displacement gear driven
WORKING PRESSURE :	2 400 Psi (16.5 Mpa) Full flow filtration

### CAB

- ROPS / FOPS
- Operator seat - fully adjustable, weight compensating with built in suspension
- Seat belt
- Optional bolt on open station
- Optional air-conditioning

### SERVICE CAPACITIES

COOLING SYSTEM :	32 Liters (50% Anti-freeze)
ENGINE CRANKCASE :	16 Liters
REAR AXLE DIFFERENTIAL :	16 Liters
TRANSMISSION :	15 Liters
DIESEL TANK :	150 Liters
HYDRAULIC SYSTEM :	80 Liters
4x4	
FRONT DIFFERENTIAL :	12 Liters
PLANETARY HUB :	2.5 Liters each end

### OPERATIONAL WEIGHTS

T :	3 920kg
V :	10 200kg
D/T :	18 000kg

### OPTIONAL EQUIPMENT

- Custom painting
- Stainless steel exhaust

### HITCH

- Hydraulic cradle hitch with 90mm BAU or LCM hitch
- Weight Transfer Hitch (Optional)

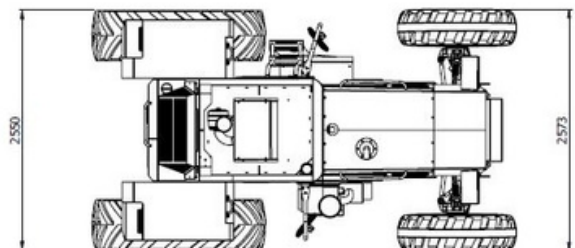
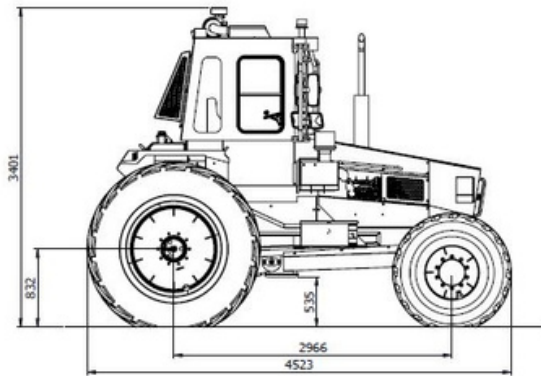

**CALL : 0800 DEZZI / 33994**  
 Head Office: +27 (0)39-685 4100  
 Email: info@dezzi.co.za  
 www.dezzi.co.za