



DEZZI H140T RIGID HAULER TRACTOR

4X4 | 4X2



BUILT AFRICA TOUGH

Designed & Manufactured in South Africa

www.dezzi.co.za



DEZZI H140T RIGID HAULER TRACTOR

SPECIFICATION SHEET

*Desmond Equipment SA (Pty) Ltd reserves the right to modify specifications without notice.

ENGINE

MAKE :	Cummins	Cummins
MODEL :	6 BTA 5.9 Turbocharged	QSB 6.7 Turbo Intercooled
CAPACITY :	5.9 Liters	6.7 Liters
POWER :	149kW @ 2 200RPM	142kW @ 2 400RPM
TORQUE :	815Nm @ 1 600RPM	930Nm @ 1 500RPM

TRANSMISSION

MAKE :	Allison	JCB
MODEL :	3000 World Series	PS 900
GEARING :	Full power shift	Full power shift
GEARS :	Forward - 6	Forward - 6
	Reverse - 1	Reverse - 1
SPEED :	40Km/H	40Km/H
TORQUE CONVERTER :	TC 411	TC W300

AXLES

	4X2	4x4
FRONT :	Dezzi non-drive with air ride suspension	ITL SD 55 Drive Pivoting steering axle
REAR :	Rockwell PRC 673P	Rockwell PRC 673P

TYRES

	4x2	4x4 (1)	4x4 (2)
FRONT :	10.5 x 16	380 R24	420 R24
REAR :	23.5 R25	600 R38	650 R38

BRAKES

TYPE :	S-Cam air brake
SIZE :	16.5" x 5" drum brake
PARK BRAKE :	Spring applied with emergency failsafe

STEERING

- Fully hydraulic orbital controlled steering with double-acting cylinder
- Full flow filtration
- Working pressure - 1500 Psi (10.3 Mpa)

ELECTRICS

VOLTAGE :	12 Volt
BATTERY :	1 x 12 Volt sealed type
ALTERNATOR :	12 Volt / 70 Amp

PNEUMATIC SYSTEM

CAPACITY :	40 Litres
WORKING PRESSURE :	120 Psi (8.1 Bar) Unloader valve controlled

HYDRAULIC SYSTEM

OIL CAPACITY :	80 Liters
PUMPS :	Fixed displacement gear driven
WORKING PRESSURE :	2 200 Psi (15.1 Mpa) Full flow filtration

CAB

- Fully adjustable, weight compensating seat with built in suspension
- ROPS and FOPS certified
- Seat belt
- Cab light
- Fully enclosed & lockable
- Optional air-conditioning
- Cab access - side door, L/H side
- Windscreen wiper
- Roof mounted ventilation fan

SERVICE CAPACITIES

COOLING SYSTEM :	32 Liters (50% Anti-freeze)
ENGINE CRANKCASE :	21 Liters
REAR AXLE DIFFERENTIAL :	16 Liters
TRANSMISSION :	15 Liters
DIESEL TANK :	275 Liters / 350 Liters
HYDRAULIC SYSTEM :	80 Liters
	4x4
FRONT DIFFERENTIAL :	12 Liters
PLANETARY HUB :	2.5 Liters each end

OPERATIONAL WEIGHTS

FRONT AXLE :	2 300kg - 2 500kg
REAR AXLE :	4 600kg - 4 900kg
TOTAL TARE :	6 900kg - 7 400kg
GCM :	48 000kg - 56 000kg

OPTIONAL EQUIPMENT

- Cab heater
- Radio
- Engine monitoring system
- Custom painting
- Stainless steel exhaust
- Air conditioner

HITCH

- Hydraulic cradle hitch with 90mm ball or LCM hitch
- Weight Transfer Hitch (Optional)

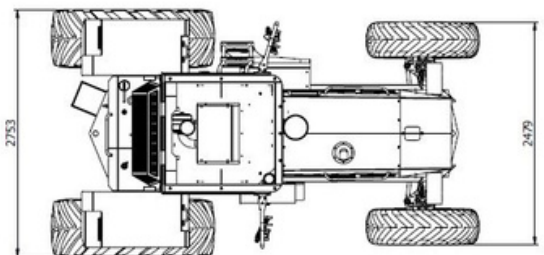
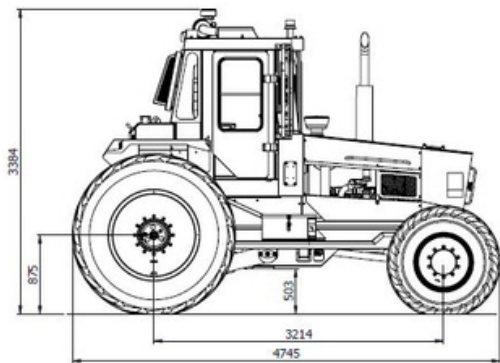

BUILT AFRICA TOUGH



CALL : 0800 DEZZI / 33994

Head Office: +27 (0)39-685 4100

Email: info@dezzi.co.za

www.dezzi.co.za