



DEZZI AT20B ARTICULATED TIMBER TRUCK

6X6



BUILT AFRICA TOUGH

Designed & Manufactured in South Africa

www.dezzi.co.za



AT20B ARTICULATED TIMBER TRUCK

SPECIFICATION SHEET

*Desmond Equipment SA (Pty) Ltd reserves the right to modify specifications without notice.

ENGINE

TYPE : Cummins
 MODEL : QSB 260 - TIER 3
 CAPACITY : 6.7 Liters
 POWER : 194kW @ 2200RPM
 TORQUE : 990Nm @ 1500RPM

TRANSMISSION

TYPE : ZF
 MODEL : 6WG210
 GEARING : Constant mesh counter shaft with integral drop box
 GEARS : Forward - 5
 Reverse - 3
 SPEED : 42Km/H
 TORQUE CONVERTER : Single phase 3 element, lock-up clutches effective in all gears. Downshift protection.

AXLES

FRONT : ZF MT-D 3095 axle - with self leveling air-ride suspension
 REAR : Dezzi tandem-drive free-swinging walking beam.
 Rockwell differential with reduction in tandem.
 Heavy duty SAHR park brake.

TYRES

FRONT : 20.5 R25 REAR : 20.5 R25

BRAKES

FRONT WHEELS : S-cam failsafe drum brakes
 REAR WHEELS : Dry disc caliper brakes
 PARK BRAKE : Failsafe spring-applied hydraulic release

FRAME

Heavy duty robust frame, front and rear with tube type oscillation, adjustable

STEERING

- Articulated with 40 degree steering angle either side
- Load-sensing, orbital-controlled
- Ground driven emergency steering

ELECTRICS

VOLTAGE : 24 Volt
 BATTERY : 2 x 12 Volt sealed type
 ALTERNATOR : 24 Volt / 70 Amp

HYDRAULIC SYSTEM

OIL CAPACITY : 160 Liters
 PUMPS : Variable displacement piston pump
 WORKING PRESSURE : Steering - 13.7 Mpa
 Tipping - 17 Mpa
 Full flow filtration

CAB

- Fully adjustable weight compensation swivel seat with seat belt
- ROPS and FOPS certified
- Rubber mounted
- Windscreen wiper
- Fully enclosed and lockable
- Rotating orange beacon light
- Rear cab night working lights

SERVICE CAPACITIES

COOLING SYSTEM : 50 Liters
 ENGINE CRANKCASE : 21 Liters
 FRONT DIFFERENTIAL : 36 Liters
 FRONT PLANETARY HUBS : 8 Liters per side
 REAR TANDEM DRIVE : 185 Liters
 TRANSMISSION : 18 Liters
 DIESEL TANK : 250 Liters

OPERATIONAL WEIGHTS

	Tare	Gross	Payload
FRONT AXLE :	8 520	10 240	1 720
MIDDLE AXLE :	4 440	13 580	9 140
REAR AXLE :	4 440	13580	9140
TOTAL :	17 400	37 400	20 000

STANDARD EQUIPMENT

- Emergency braking
- Full belly-plate protection
- Rear window guard
- Tinted windows
- Front tow hooks
- Back-up alarm
- Full road ordinance lights

LOAD CAPACITY

32,0m3

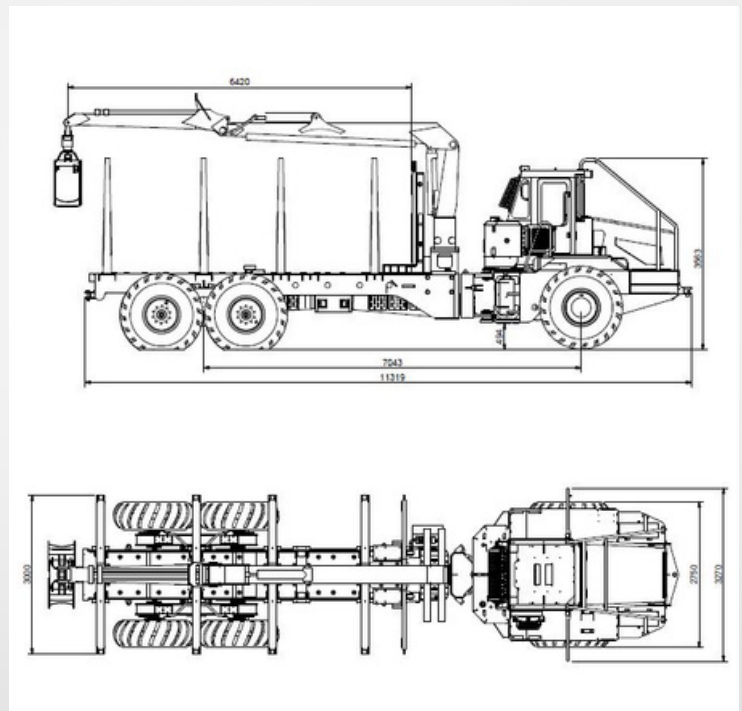

CALL : 0800 DEZZI / 33994
 Head Office: +27 (0)39-685 4100
 Email: info@dezzi.co.za
 www.dezzi.co.za