

DEZZI



3 WHEEL 70 LOGGER



BUILT AFRICA TOUGH
Designed and Manufactured in South Africa



**BUILT AFRICA
TOUGH**

3 WHEEL LOGGER

ENGINE

- Make : Deutz F4L912
- Power : 46KW / 230NM @ 1600RPM
- RPM : Governed @ 2000RPM
- Mounting : 6 Point Rubber Mounting
- Safety : Mechanical Shut Off

ATTACHMENT

- Timber / Brush Grapple
- 0.36m³
- Indexator 12 Ton - 45mm Pin

DRIVE PUMP

- Model : Poclain - PM50 Tandem
- Operator Control : Servo Foot Pedal Valve
- Displacement : 45cc Per Side
- Relief Valve : 350 Bar
- Charge Pump : Intergrated Gear Pump
- Charge Pressure : 25 Bar
- Drive Coupling : HD Guardex 65

WHEELS

- Tyres Front : 18.4 x 30"
- Rim Front : Reinforced 1pc
- Tyres Rear : 17.5 x 25 L4
- Rear Rim : Reinforced 1pc

BRAKES

- Type : Multi Disc Spring Applied
- Park Brake Release: 18 Bar Hydraulic Pressure
- Service Brake : Hydrostatic Foot Pedal Control

IMPLEMENT HYDRAULIC SYSTEM

- Pump Type : 40cc Gear Pump Driven
- Function Valve : Open Centre Valve with Port Relief

HYDRAULIC & FUEL TANK

- Hydraulic Tank Type : Frame Tubing Integrated
- Hydraulic Tank Capacity : 145L (170 For System)
- Hydraulic Oil Cooling : Electric Fan Hydraulic Cooler
- Fuel Tank Type : Bolt Mounted on Frame
- Fuel Tank Capacity : 85L

OPERATING MASS

- Front Unladen : 3960 kg
- Rear Unladen : 1450 kg
- Total Unladen : 6040 kg
- Lifting Capacity : 1300 kg

WHEEL DRIVE SYSTEM

- Wheel Motor : Poclain MSE18 2800cc
- Wheel Torque : 13300NM per Wheel

CABIN STANDARD

- Type : Frame Intergrated. Full driver protection with guarded side doors and front windscreen
- Seat Belt : Suspended Lap Belt; 4 Point Harness Optional

CABIN AIR CONDITIONED

- Type : Frame Intergrated, Sealed and Pressurised
- HVAC System : 12V Fan, Engine Belt Driven Air Con Compressor
- Seat Belt : Suspended Lap Belt; 4 Point Harness Optional
- Windows : Glazed Windscreen With Wiper, Glazed Operator Door Windows
- Protection : HD Removable Windscreen Guard; Removable Operator Door Window Guards

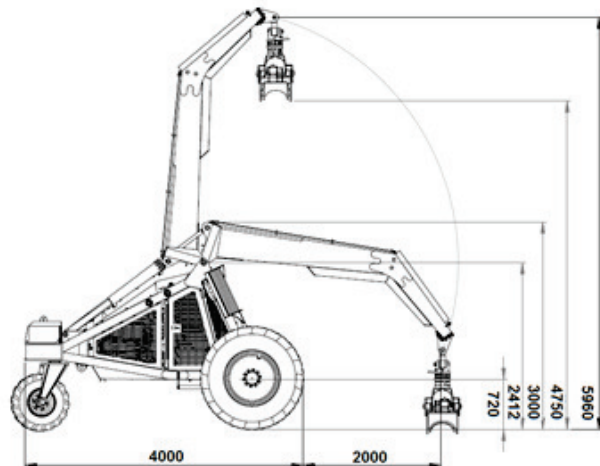
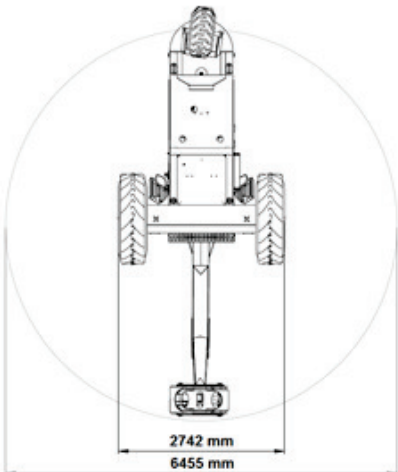

**DESMOND
EQUIPMENT**

PORT SHEPSTONE HEAD OFFICE
Tel: 039 685 4100 | Fax: 039 685 4476 | E-mail:
dezzi@venturenet.co.za
PO Box 111 Port Shepstone 4240, South Africa

Dimensions are approximate

DEALER