

CAN-AM Defender Reverse Light Kit

Installation Manual

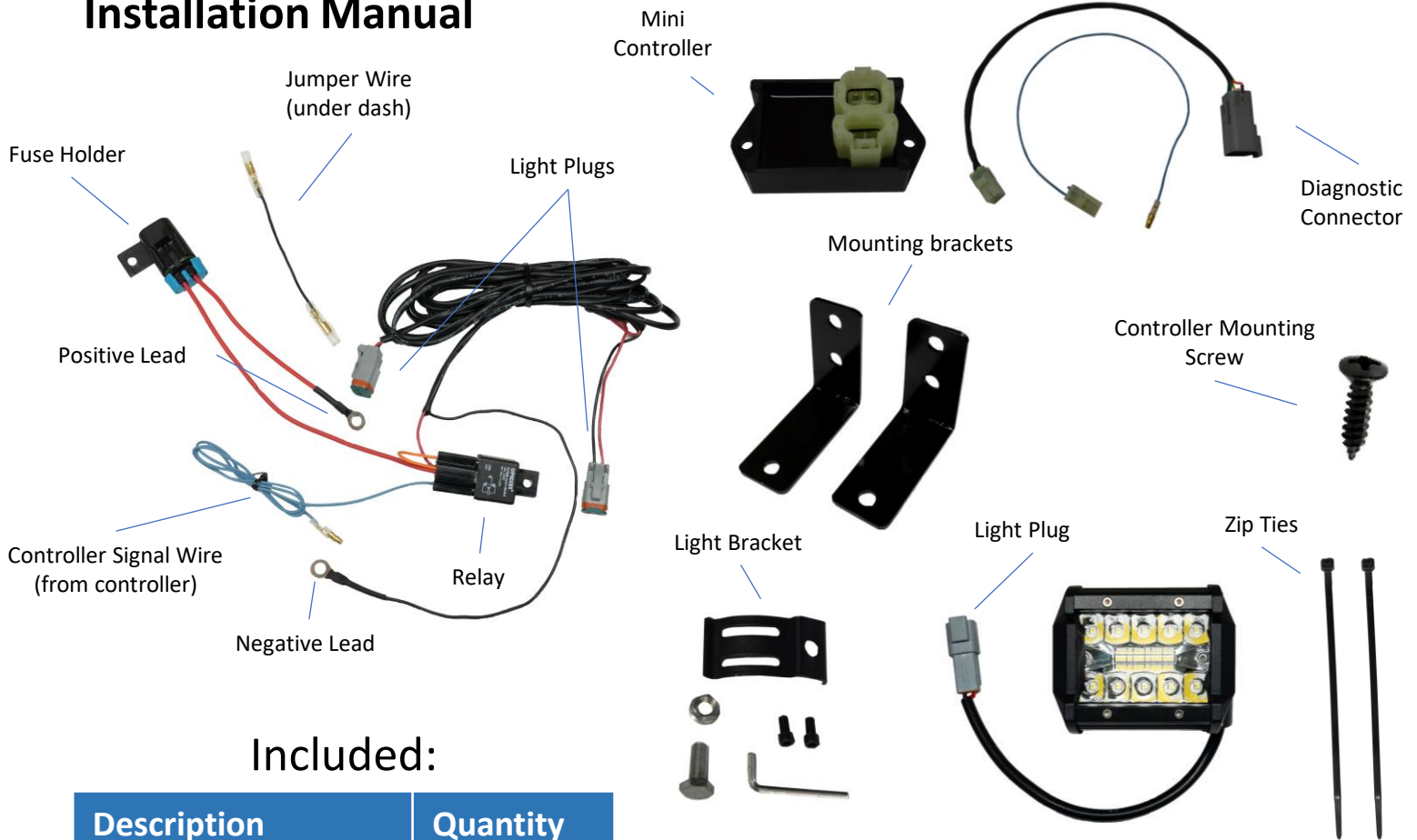

Included:

Description	Quantity
Wiring Harness	1
Jumper Wire	1
Relay	1
Mounting Brackets	2
Lights with Brackets	2
Zip Ties	8
Controller	1
Controller Mounting Screws	2

Required Tools:

13mm Socket & Ratchet
13mm Wrench
Philips Screwdriver
Flat Head Screwdriver
Torx T-40
1/16" and 5/16" Drill Bit
Wire Cutter (trimming zip ties)

Read entire manual before beginning the installation process.

Disclaimer: Sam's Backup Lights is not responsible for any damage due to improper installation.

Sam's Backup Lights
www.samsbackuplights.com

CAN-AM Defender Reverse Light
support@samsbackuplights.com

Step 1: Secure and Plug-in Controller

- 1) Remove diagnostic connector and plug connector into controller.
- 2) Secure controller with provided mounting screws; if necessary, drill 1/16" pilot hole.
- 3) Connect bullet connector to the factory solid white wire under the hood.

Note: If preexisting wires are not available or already in use refer to step 2b

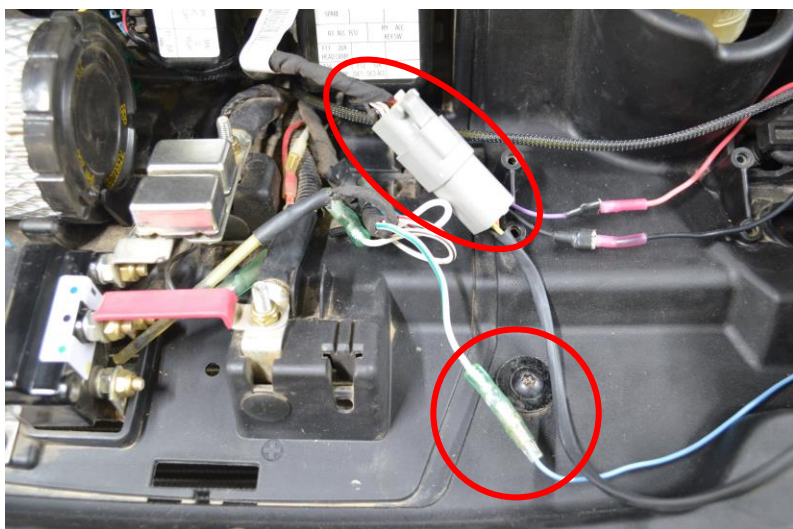
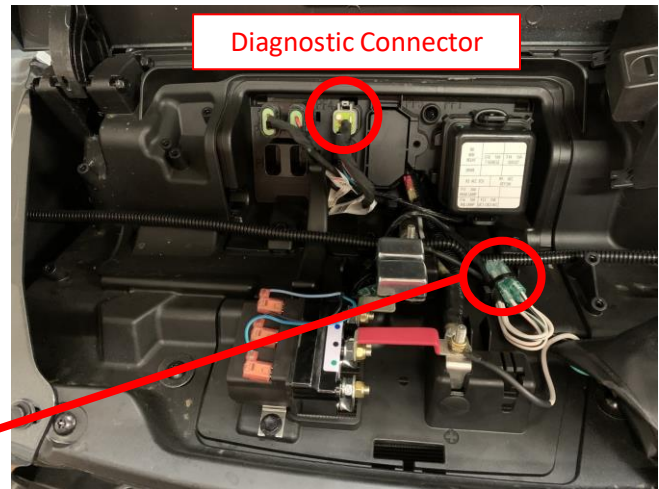
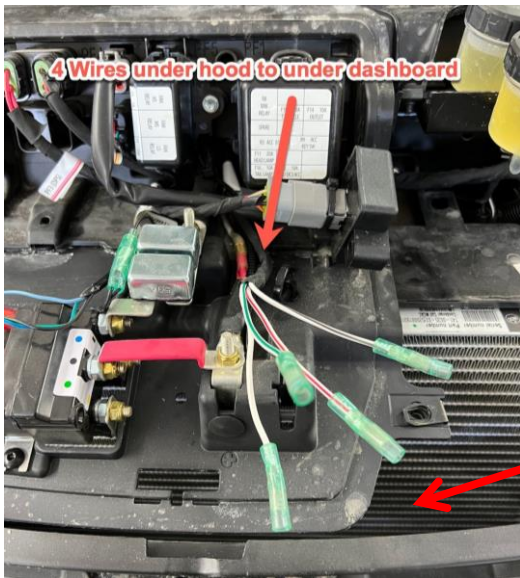

For an instructional video

Scan QR code:



Step 2a: Routing Wires Under Dash & Floor

- 1) Under the center of the dash, 4 factory wires will be visible.
- 2) Plug the 4-inch blue wire into the solid white wire, and then into the solid blue wire.
- 3) Remove the Floorboard by removing the three push rivets and pulling up.
- 4) Connect the Light Blue wire coming out of the relay to the Solid Blue wire under the previously removed floorboard.

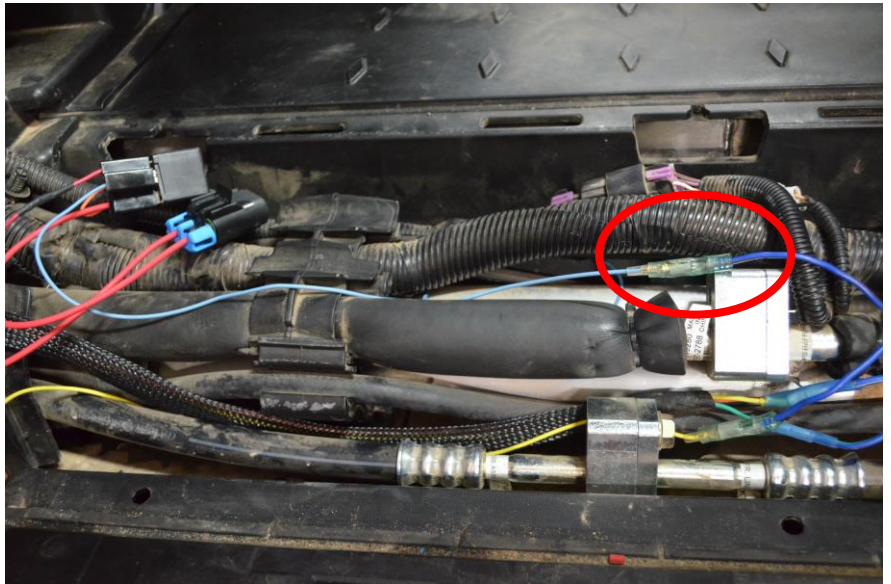

Step 2b: Routing Wires Under Dash & Floor

- 1) Plug the jumper wire provided in the kit into the Light Blue wire from the controller.
- 2) Route the jumper wire through the firewall. Remove the winch-control outlet to gain access - there is a rubber seal that runs across the frame, sealing the cab.
- 3) Connect the jumper wire to the Light Blue wire coming out of the relay.



Step 3: Mounting the LED Lights

1) Remove one T-40 bolt on upper door hinge. Install supplied bracket reinstall bolt; then, remove second bolt, slide bracket in place and reinstall bolt. Repeat on the other side.

2) Carefully drill a 5/16" hole

NOTE: If installing on an enclosed cab, use included rubber grommets in the new hole.

3) Feed the wires into the cab.



Step 4: Assemble Connector

This step applies to enclosed cab kits only.

- 1) Assemble the connector by pushing the red wire into the hole marked 1 and the black into hole 2. Push the wires in until they click into place and lock into the connector.
- 2) Push the green wedge lock in until it clicks.
- 3) Plug the connector into the light and secure the wire using zip ties.



Note: Holes are numbered on the side, near the point where the connector becomes wider



Step 5: Route LED Light Harness

- 1) Remove the plastic cover near the lower door hinge.
- 2) Run wires (ring terminal and relay terminal ends) from inside the cab down the inside of rear passenger pillar; retrieve wires from the hole right below the lower door hinge.
- 3) Route wire up to the battery.

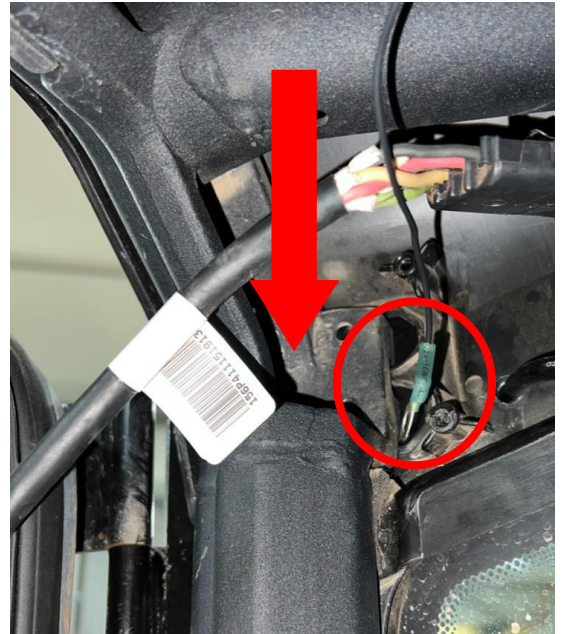

Step 6: Attach Power Leads and Relay

- 1) Attach black ring terminal to negative battery terminal.
- 2) Plug remaining red relay terminal into relay housing; insert relay into housing. Push in until it clicks.
- 3) Attach red ring terminal to positive battery terminal.
- 4) Secure fuse and relay using zip ties.

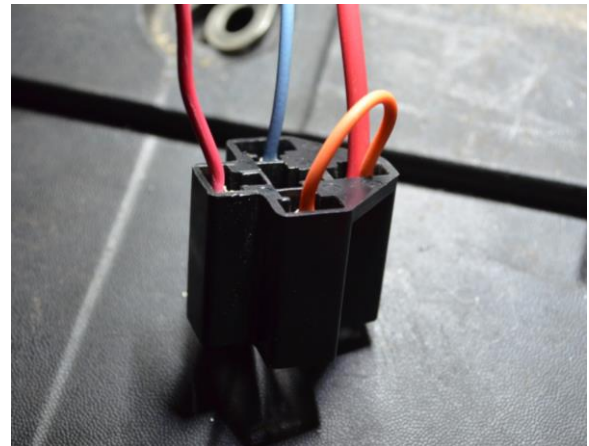
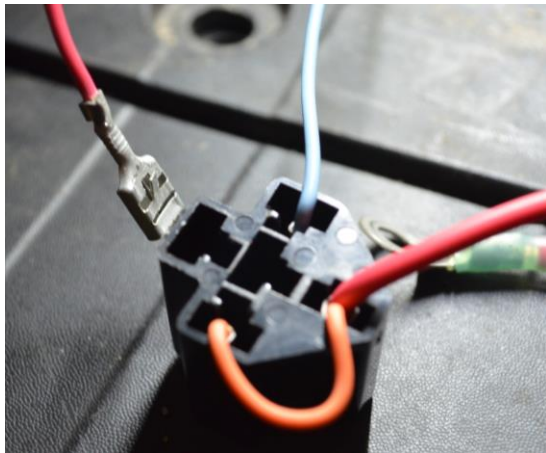

Automatic Reverse Light Wiring

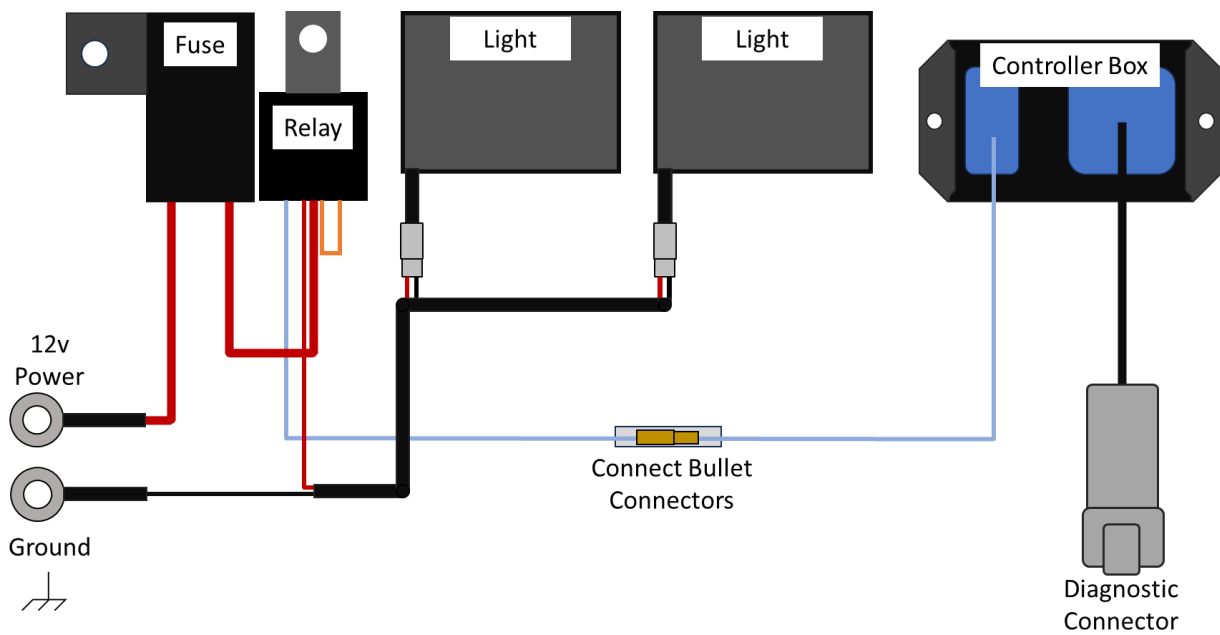

Factory Can-Am Diagnostic Connector

The Orange wire from Sam's Controller needs to match the Orange/Green wire on the factory Can-Am diagnostic connector



Can-Am 2021+ Diagnostic Connector



Can-Am Pre-2021 Diagnostic Connector



Install wedge lock (Green) with small screwdriver or pliers and sealing plug (White) into empty hole



Operation of Reverse Lights

Sam's Backup Lights are automatic. **NO switches or programming required.** When the vehicle is shifted into reverse, the lights will automatically come on. The controller has been programmed with a manual override feature, so back-up lights can be turned on without the vehicle needing to be shifted into reverse.

- **Fully Automatic When Shifted to Reverse**

- 1) No programming needed

- **Manual Override Function**

- 1) Shift the vehicle into Neutral
- 2) Press and hold the brake pedal for up to 2 seconds. The reverse light will automatically turn on and stay on.

***To turn the light off repeat this procedure.**

Operation of Auxiliary Output Option

- **Manual Override Function**

- 1) Auxiliary output is turned ON by pressing the TRIP button two times within 1 second while in Park, Neutral, High, or Low gear

***To turn the accessory off repeat this procedure.**

Note: If the ignition is turned off while the vehicle is in reverse, or the manual override function is enabled, the lights will remain ON until the ECU enters sleep mode (approximately 30 secs to 2 minutes depending on vehicle and ECU type).