

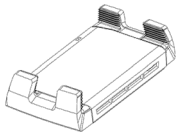

Parts Provided

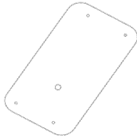

Wireless
Charger



Installation
Template



Self tapping
Screw (x4)

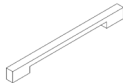

Spreader Bar

Tools Required



Phillips Head
Screwdriver



1/4" Drill Bit (for wire
hold) and 3/32" Drill
Bit (for screw holes)

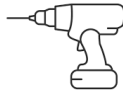

Electric Drill

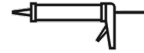

3M 5200 (optional)

Technical Information

Input Voltage Range	10-30V DC (12 / 24V system)
Input Current Max	2A
Output Power	15W (9V, 1.66A)
Standby current Draw	< 0.3W
Waterproof rating	IPx6 front and back
Certifications	Qi, CE, FCC, ROHS, UNECE R10 E24, RCM

Installation Guide

Step 1: Identify the installation location. The charger should be installed in a flat area where the back of the charger is completely flush with the surface it is being mounted to. Confirm that the clamping arms of the charger are able to be fully extended without interference. We recommend that you install the charger vertically to better secure your phone in rough conditions.

Step 2: Carefully place the provided Installation Template in the selected location. In the designated areas, drill pilot holes for the mounting screws using a 3/32" drill bit and then drill a hole for the power wire using a 1/4" drill bit. Remove installation template when complete.

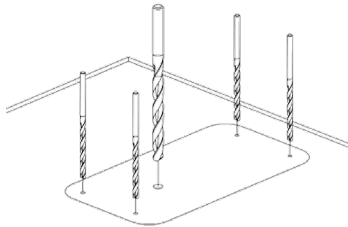

Step 3: Spread the clamping arms of the charger and insert the provided Spreader Bar into the wireless charger as shown below.

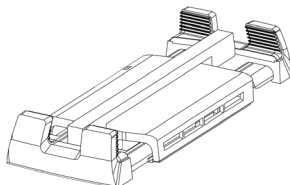

Step 4: Thread the wireless charger's power wire through the 1/4" drill hole. Re-confirm that the clamping arms of the charger can be fully extended without interference. Align the charger's mounting holes with the 3/32" drill holes and screw charger in place with the provided self tapping screws.

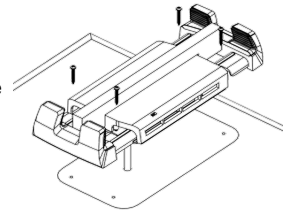

Step 5: Using a 2A fuse, attach wires to a 12/24V power supply and ensure there is a waterproof connection

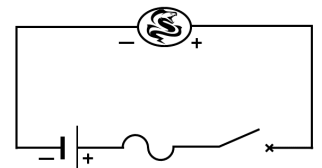

Step 6: Make sure the charger was installed correctly by placing a wireless charging compatible device in the charger. Check that the device is charging a few seconds after you place it on the wireless charger.

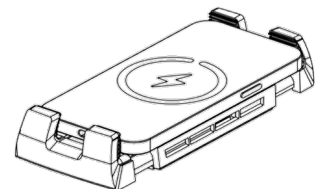

Contact:

orders@aquaamp.com
1108 Eldridge St, Clearwater, FL 33755

For further information visit www.aquaamp.com

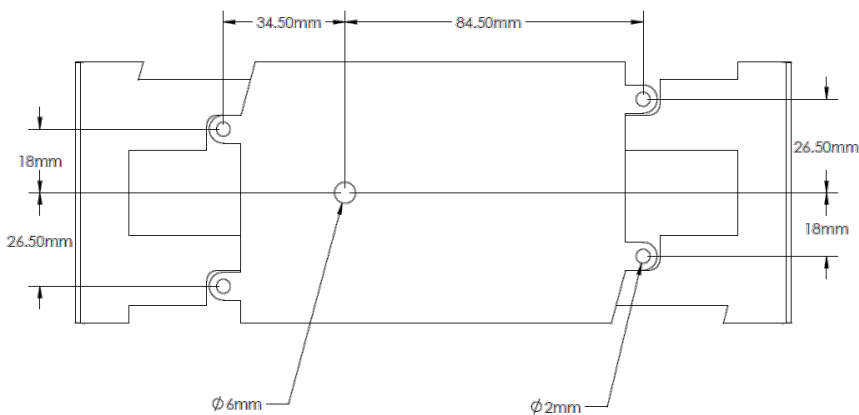
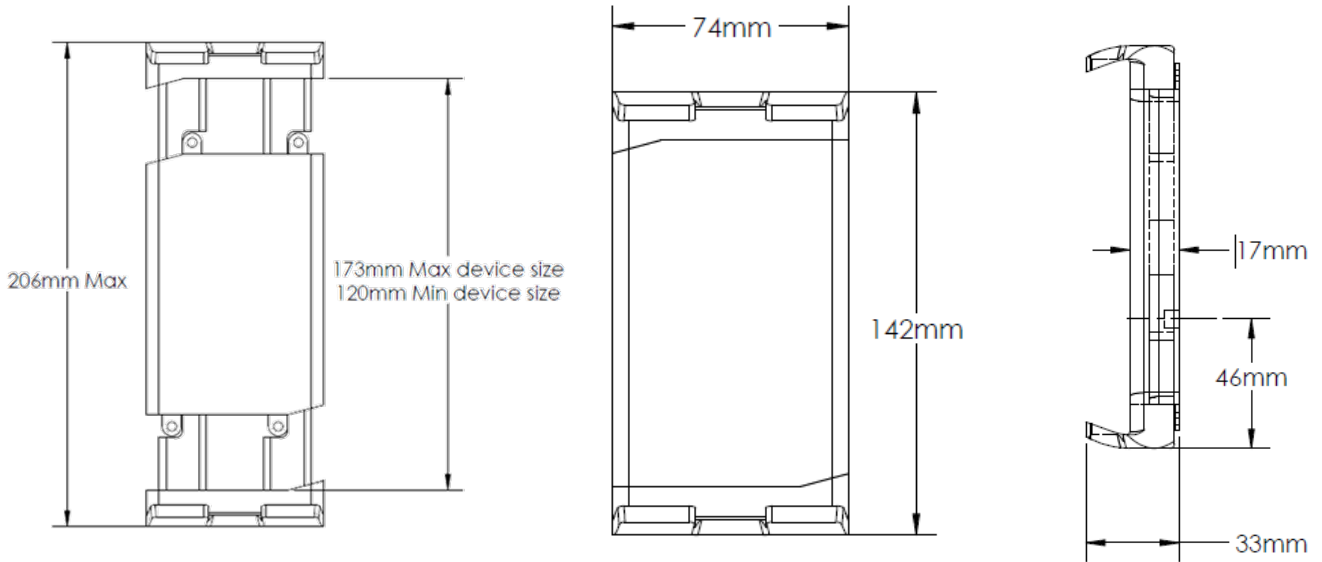

Technical Information

Input Voltage Range	10-30V DC (12 / 24V system)
Input Current Max	2A
Output Power	10W (9V, 1.66A)
Standby current Draw	< 0.3W
Waterproof rating	IPx6
Certifications	Qi, CE, FCC, ROHS, UNECE R10 E24, RCM

Contact:

orders@aquaamp.com
1108 Eldridge St, Clearwater, FL 33755

For further information visit www.aquaamp.com