

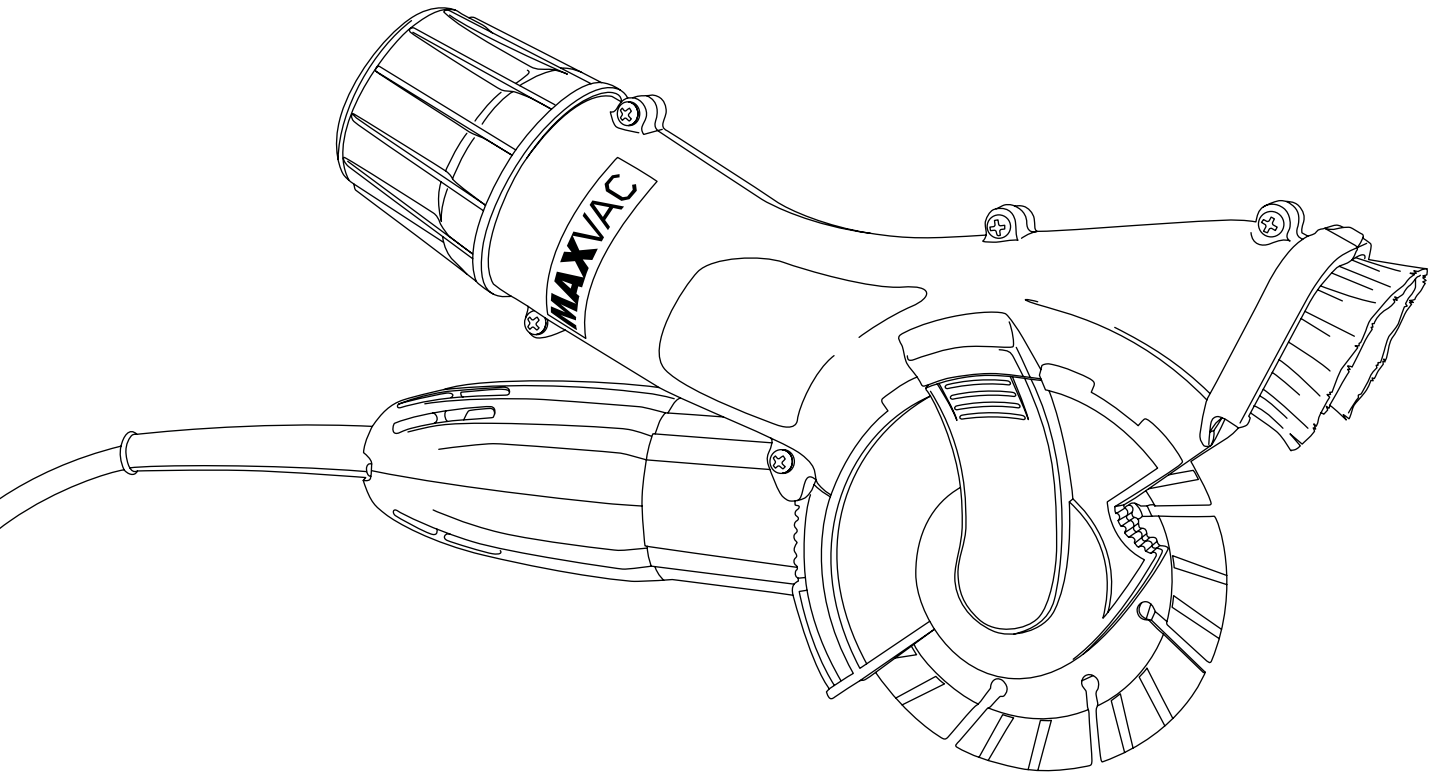

AGS-125

Installation Guide Makita Grinders

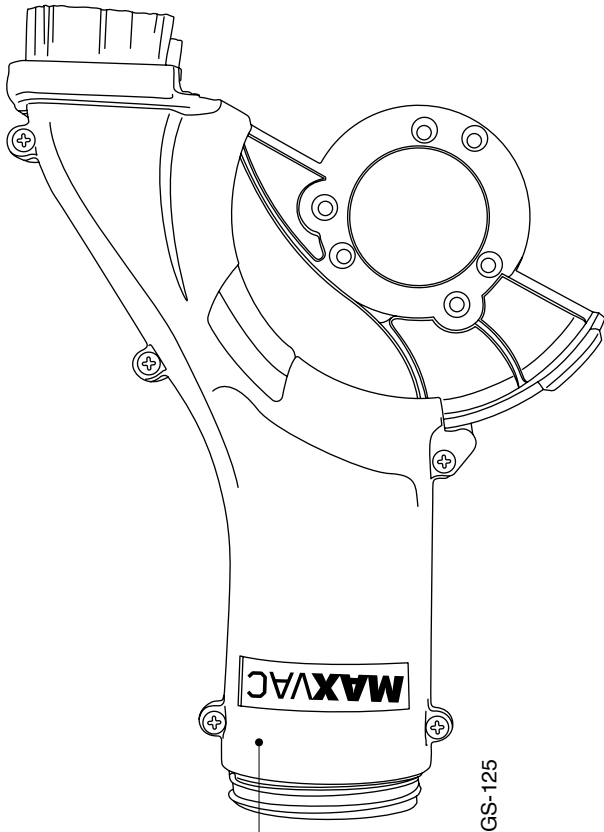



AGS-125

A x1

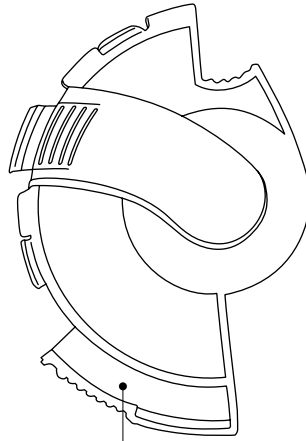

B x1

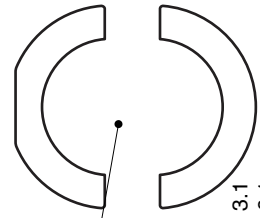

3.1
6.1
6.2
7.0

C x4

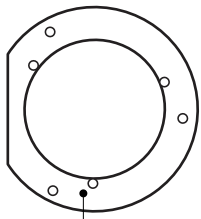

SPR04

D x1

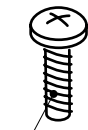

E x2

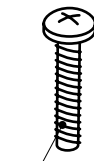

F x3

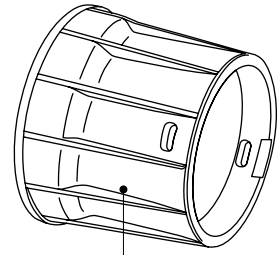

G x1

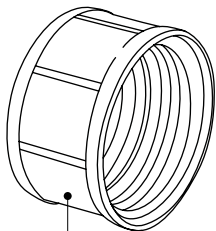

H x1

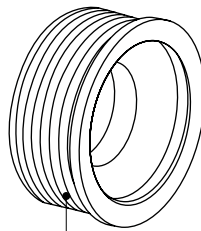

I x1

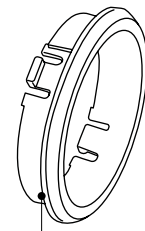

J x1

Check your grinder model below to see what Adaptor (and Spacer) you will need.

Model Number	Adaptor (C)	Spacer (D)	Model Number	Adaptor (C)	Spacer (D)
DGA 456	6.1	SPR04	M9502R	3.1	SPR04
DGA 452	6.1	SPR04	9015B	7.0	SPR04
DGA 454	6.1	SPR04	9527NB	6.1	SPR04
DGA 4540C	6.1	SPR04	9553 NB	6.1	SPR04
DGA 463	6.1	SPR04	9555 NB	6.1	SPR04
DGA 467	6.1	SPR04	9557NB	6.1	SPR04
DGA 5021C	6.1	SPR04	9558 HN	6.1	SPR04
DGA 504	6.1	SPR04	9558NB	6.1	SPR04
DGA 505	6.1	SPR04	9558PB	6.1	SPR04
DGA 513Z	6.1	SPR04	9562CR	7.0	SPR04
DGA 517Z	6.1	SPR04	9562CVH	7.0	SPR04
GA022G	6.1	SPR04	9562CVR	7.0	SPR04
GA4530R	6.1	SPR04	9565CV	7.0	SPR04
GA5021	6.2	SPR04	9565CVR	7.0	SPR04
GA5030	6.1	SPR04	9565H	7.0	SPR04

Different grinder models need different adaptors and spacers. Only 1 adaptor & spacer combination per machine. Please see above chart.

If your grinder model is not listed, please email your grinder brand & model number to sales@max-vac.com and we will confirm compatibility for you.

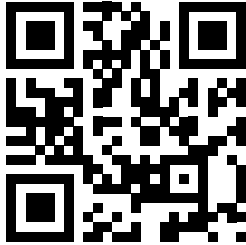
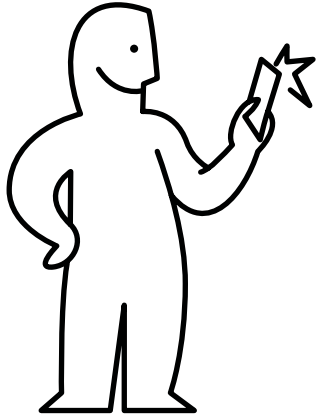

https://www.youtube.com/watch?v=MTNq_NxQi4s

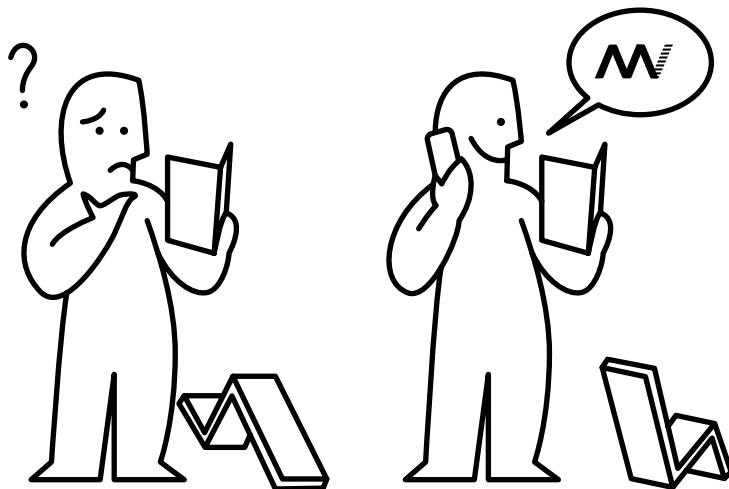

1

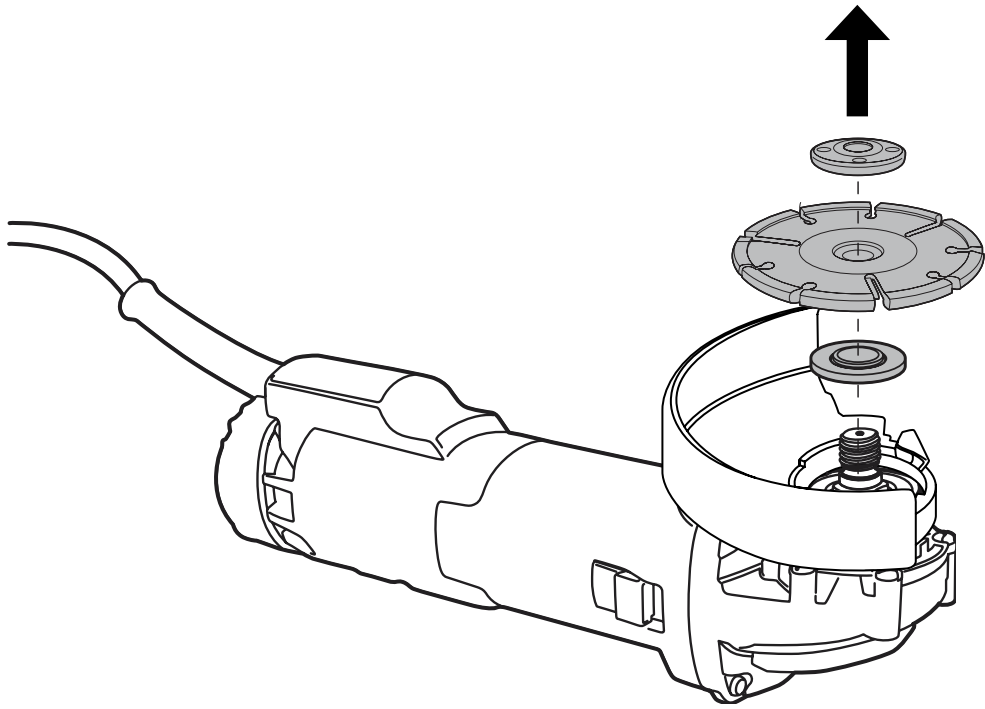

2

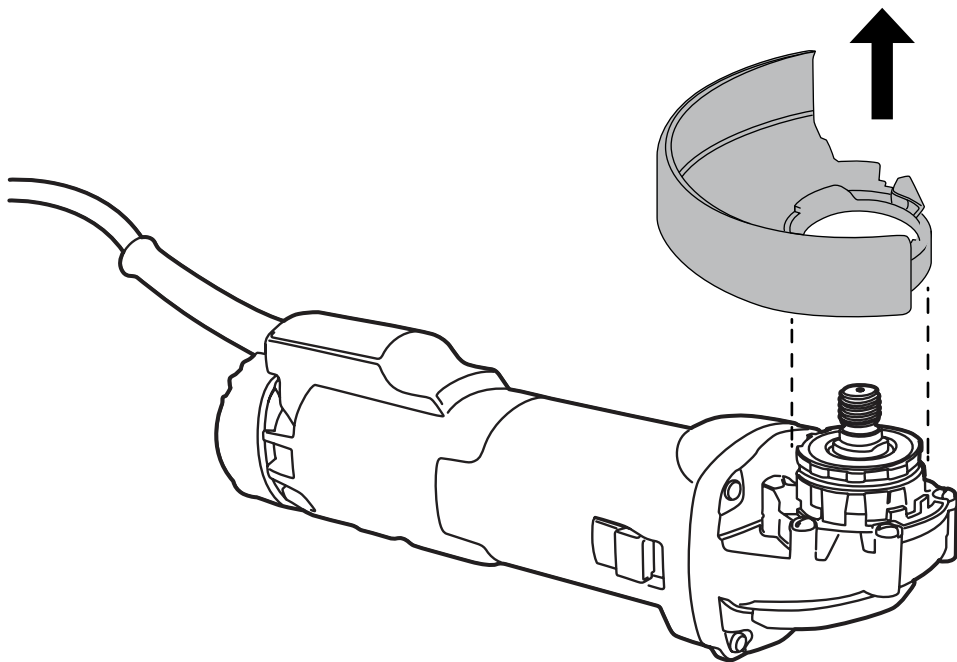

3

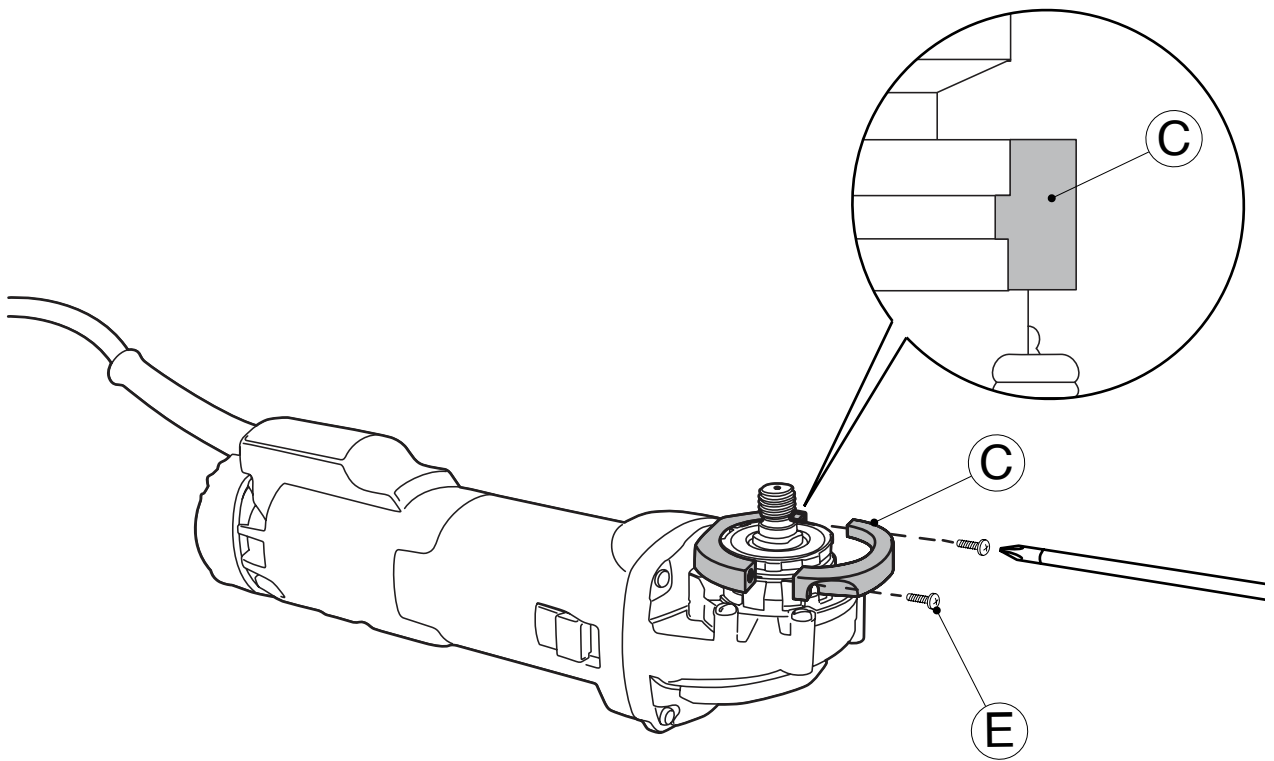
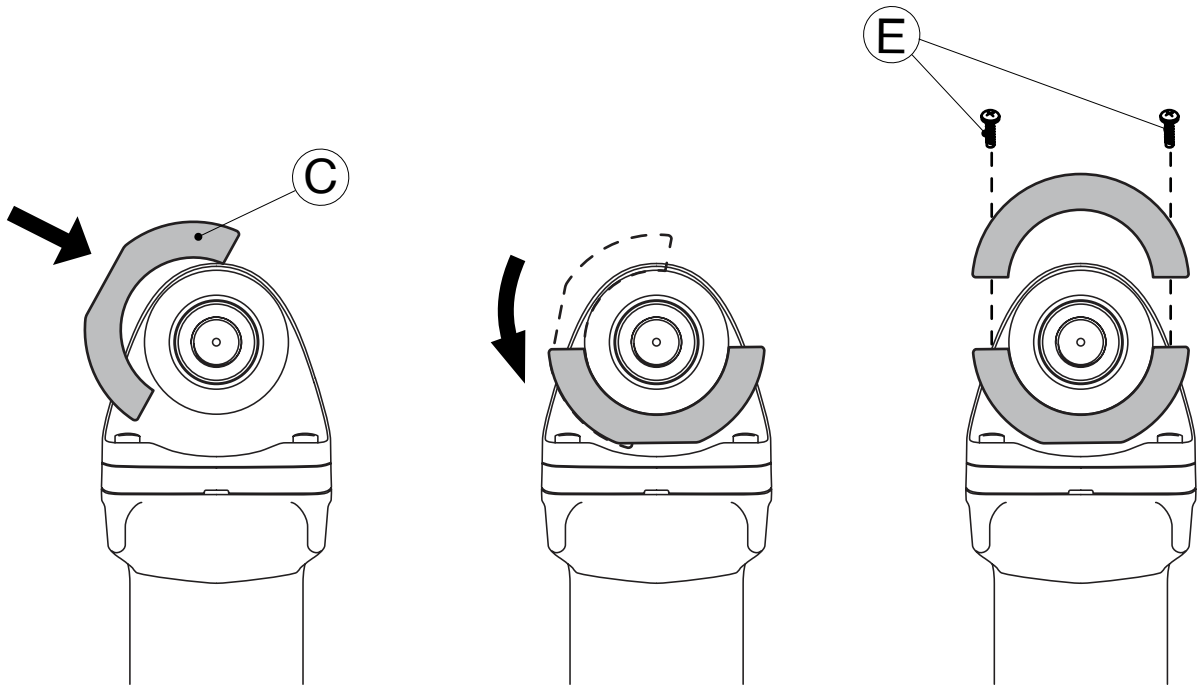

!

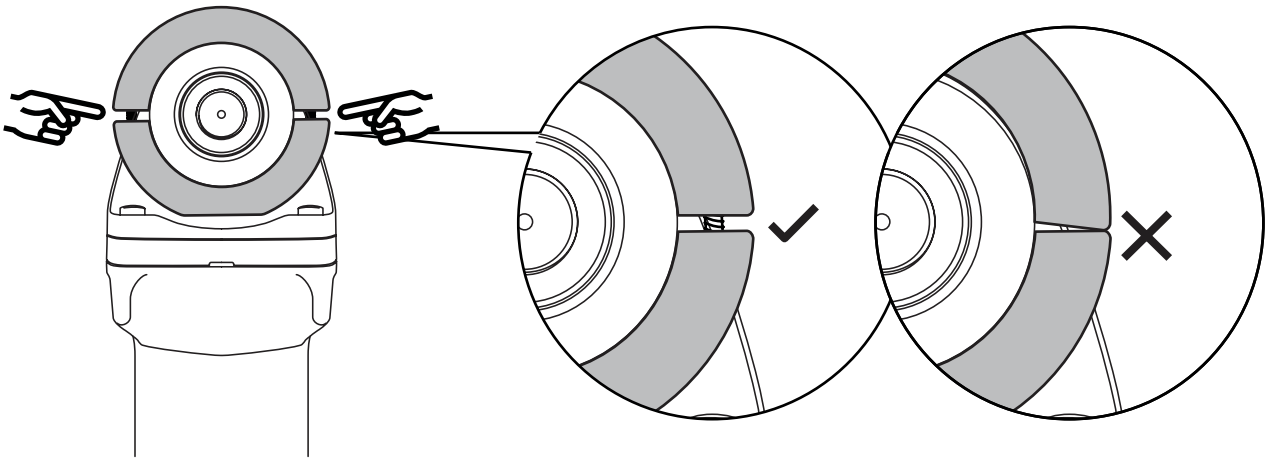

!

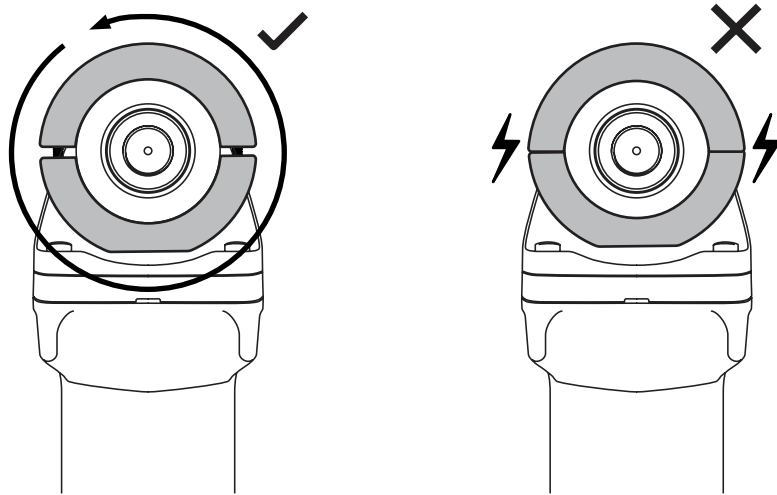

4

Spacer Ring (refer to table on p3)

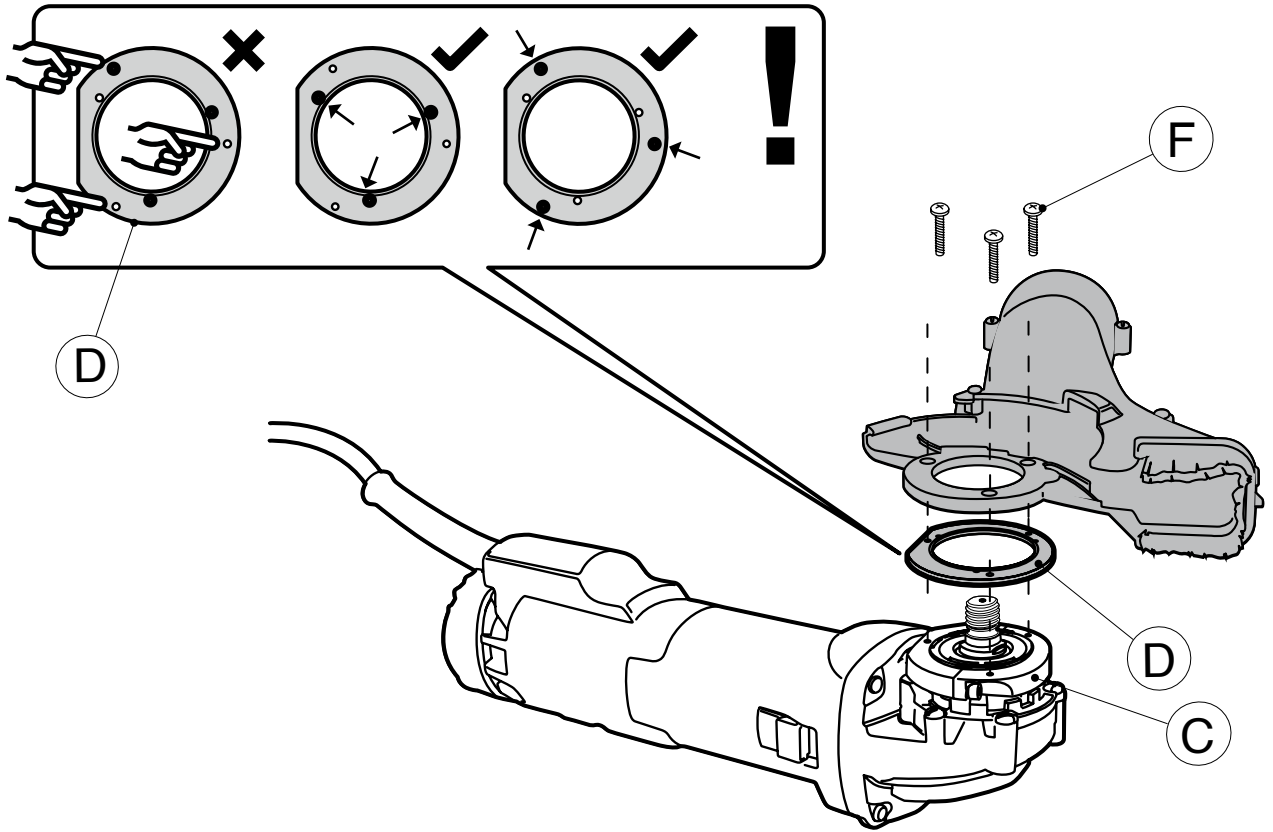

5

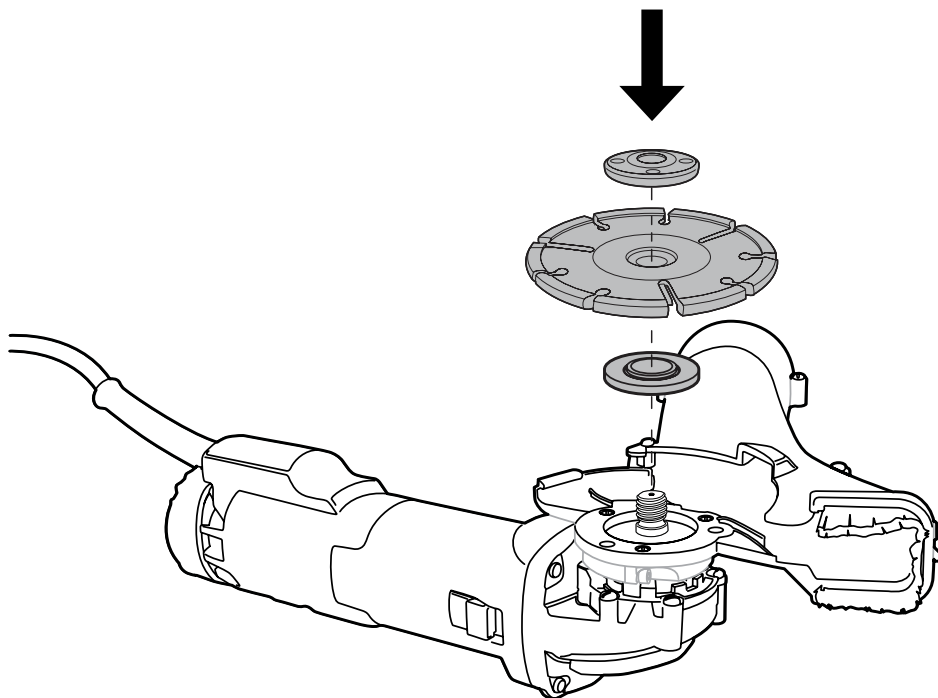

6

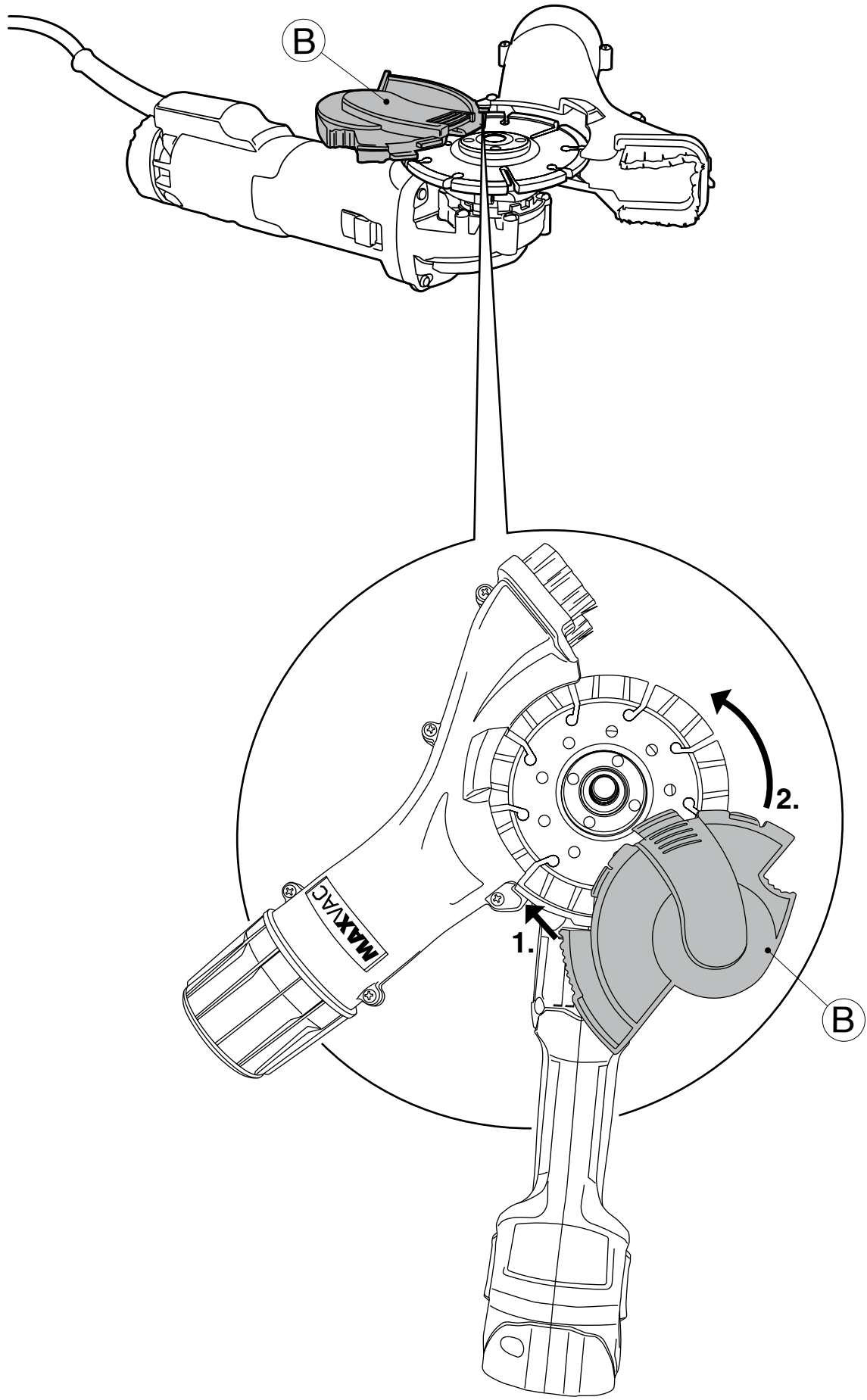

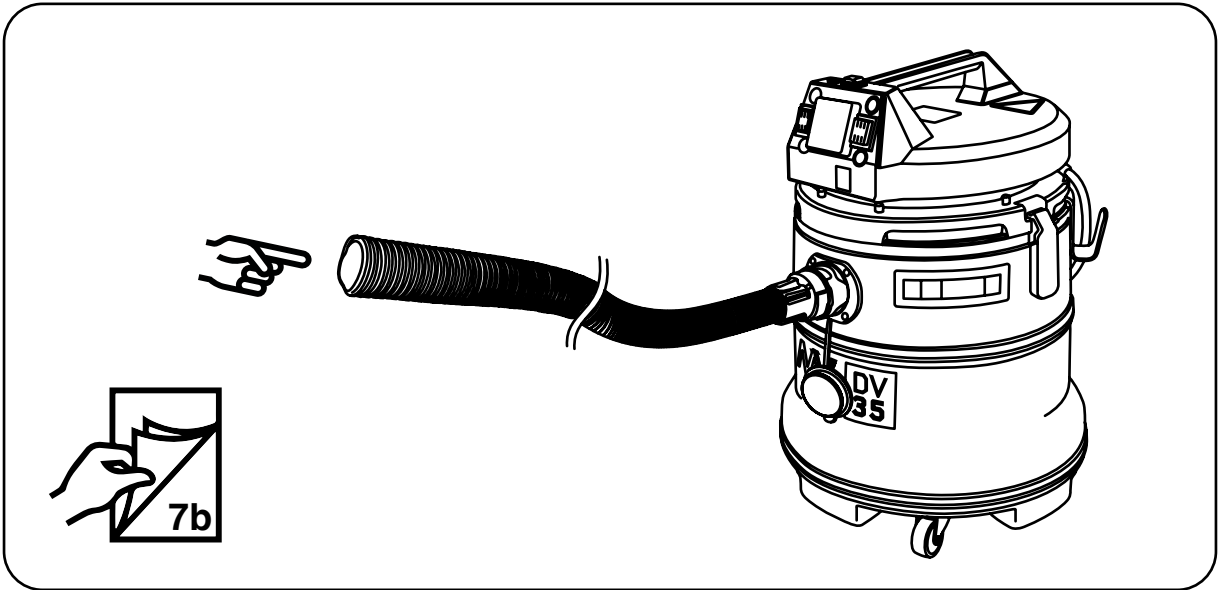
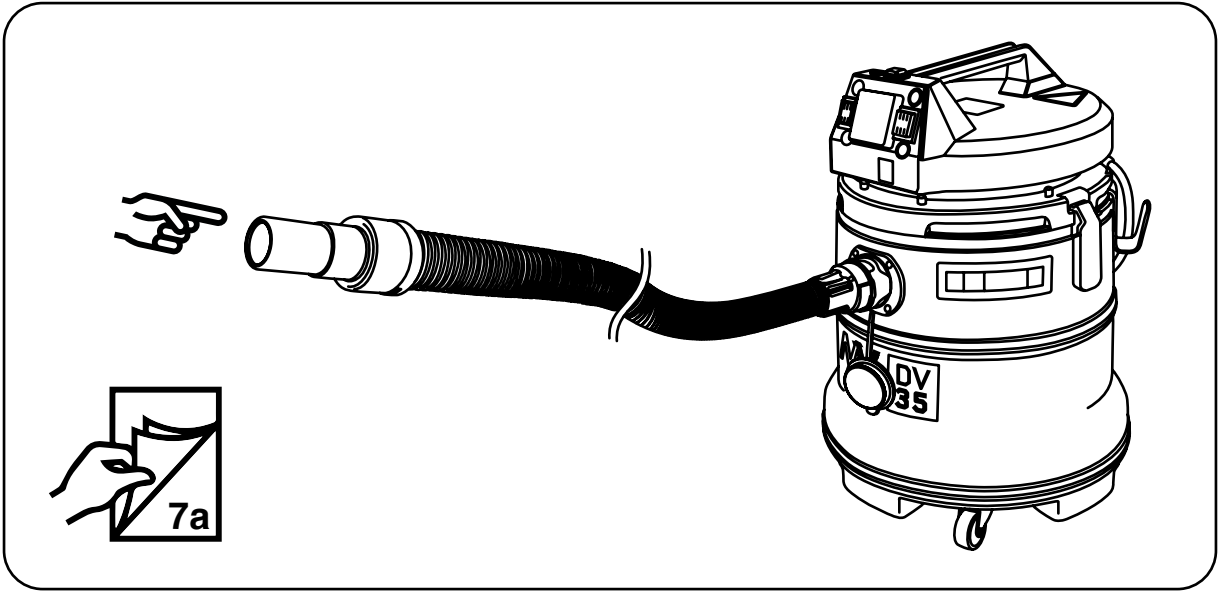

7a

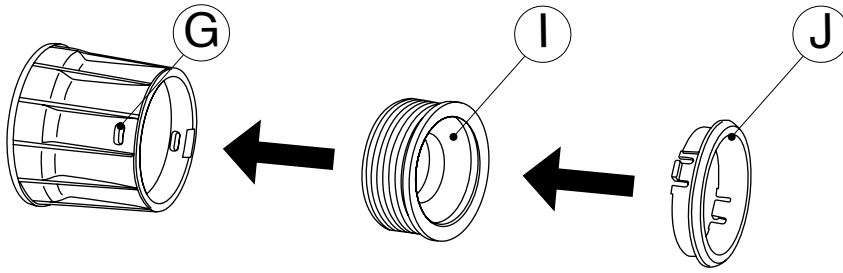

8a

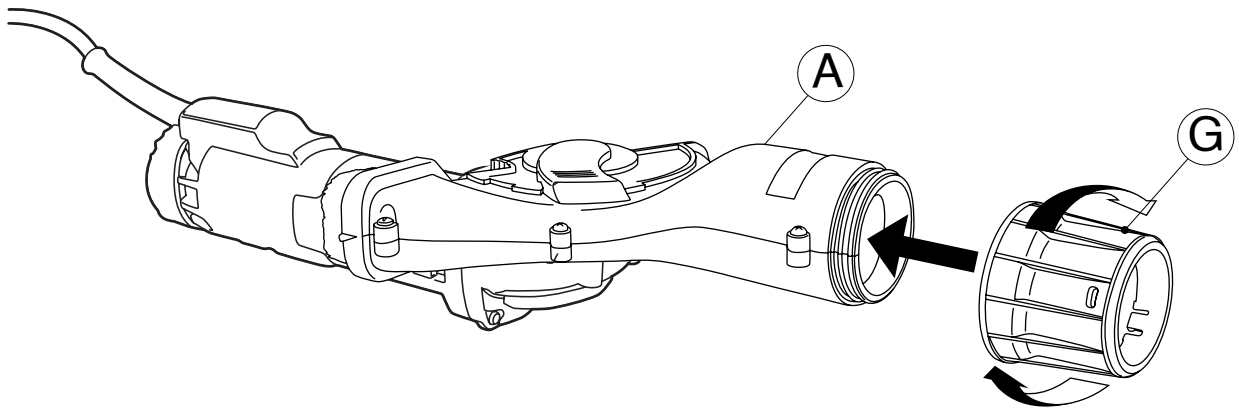

9a

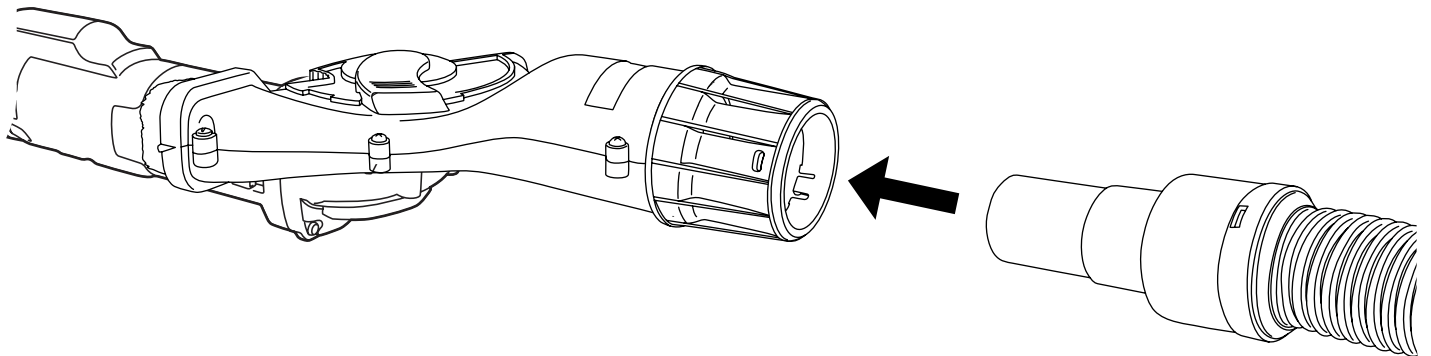

7b

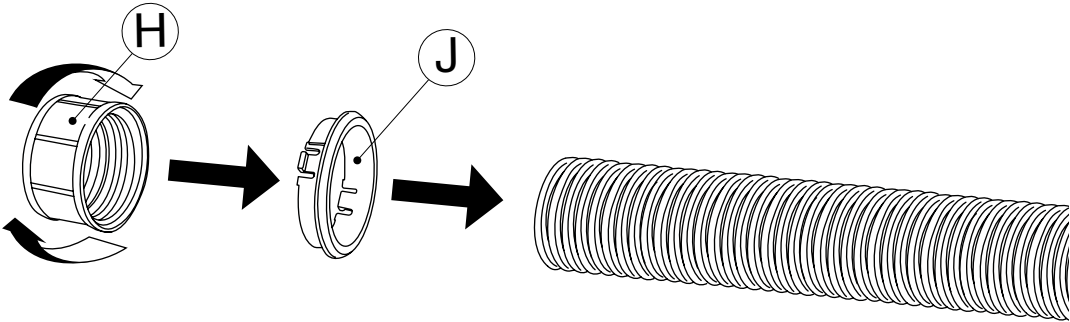

8b

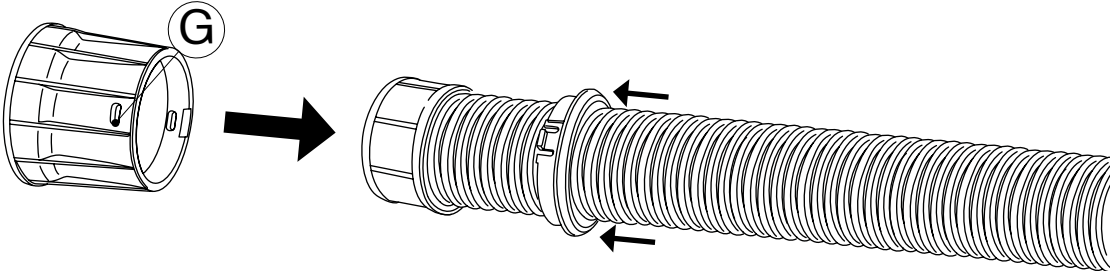

9b

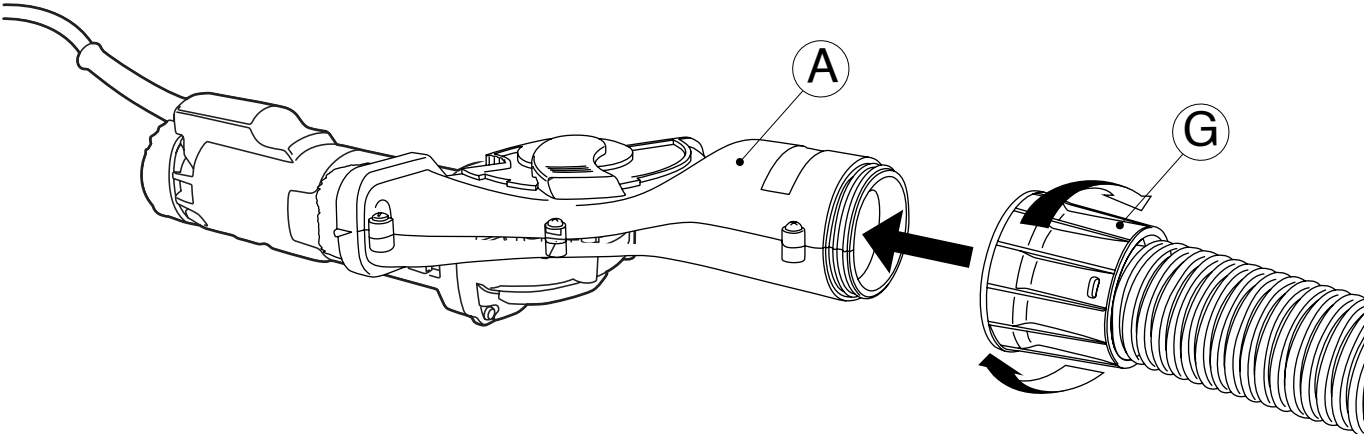

10

