

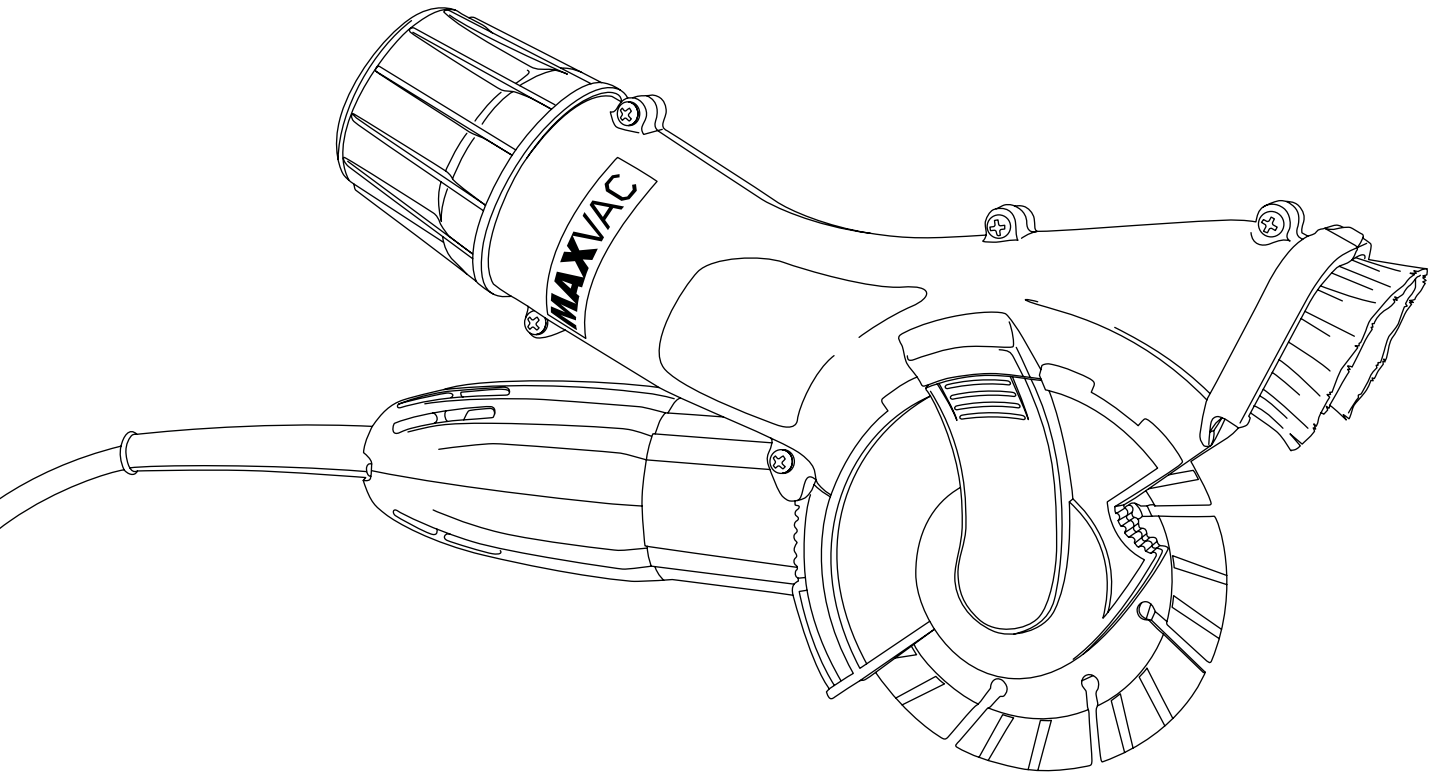

AGS-125

Installation Guide Dewalt Grinders

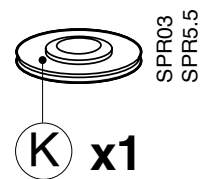

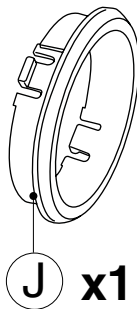
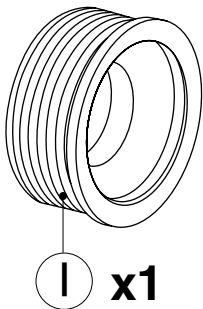
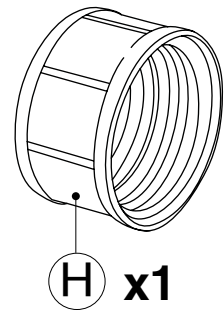
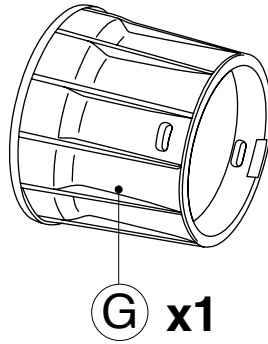
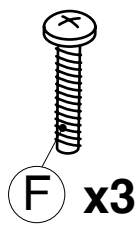
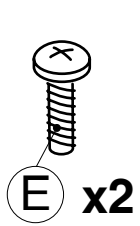
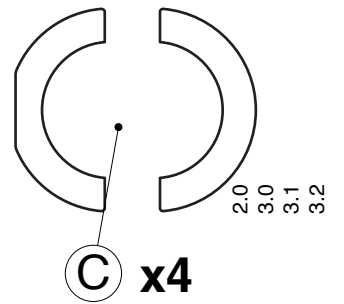
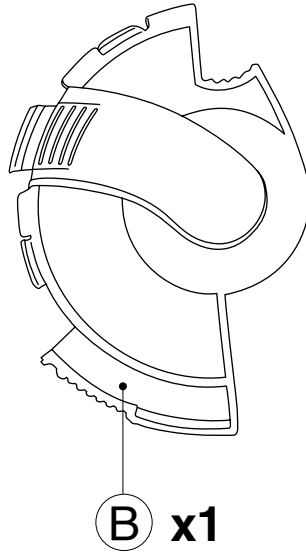
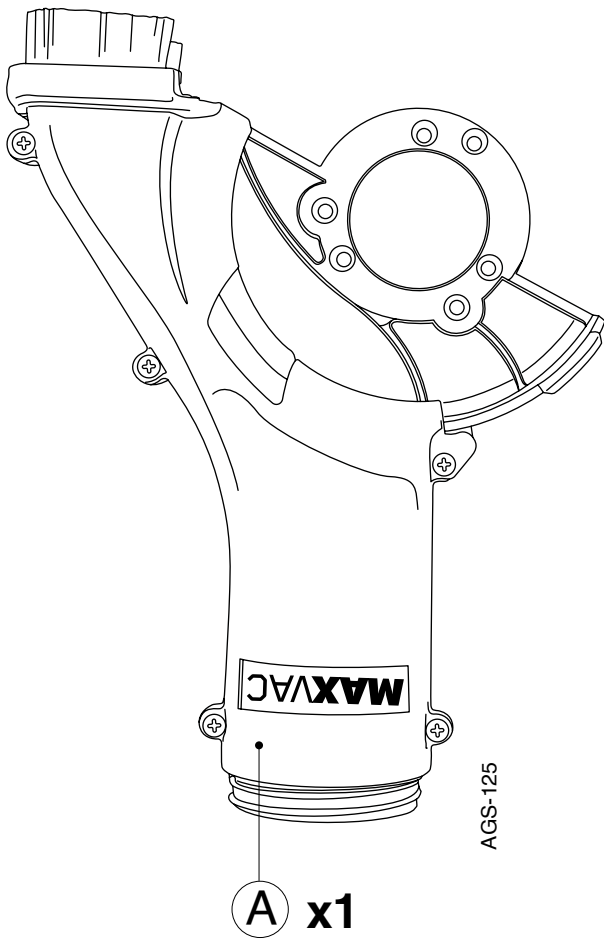

Check your grinder model below to see what Adaptor (and Spacer) you will need.

Model Number	Adaptor (C)	Spacer (K)
DW831	2.0	
Accu DCG412M3	3.0	
DWE4206	3.0	SPR03
DWE4206LX	3.0	SPR03
D28139	3.0	
DCG414 FLEXVOLT	3.2	SPR5.5
DCG418 FLEXVOLT	3.2	SPR5.5
Hitachi Cordless G18 DBL	3.0	
D28065	3.1	
D28066	3.1	
D28113	3.1	SPR03
D28113-3	3.1	SPR03
D28114	3.1	
D28115	3.1	
D28116	3.1	
D28131	3.1	
D28132	3.1	
D28133	3.1	
D28134	3.1	
D28138	3.1	
D28402	3.1	
DCG412	3.1	SPR5.5
DW821	3.1	
DW821 QS	3.1	
DW824	3.1	
DW831	3.1	

Model Number	Adaptor (C)	Spacer (K)
DWE4056	3.1	
4016	3.1	
DWE 4117	3.1	
DWE818	3.1	
D28 128-08	3.1	
DWE 4050	3.1	
DWE 4051	3.1	
DWE4202	3.1	
DWE4203	3.1	
DWE4204	3.1	
DWE4205	3.1	
DWE4207	3.1	
DWE4213	3.1	
DWE4214	3.1	
DWE4215	3.1	
DWE4216	3.1	
DWE4217	3.1	
DWE46101	3.1	
DWE46102	3.1	
DC(G)413	3.2	
DC(G)414	3.2	
DC(G)415	3.2	
DCG405	3.2	
DCG405-FN	3.2	
DCG405FN-XJ	3.1	SPR5.5

Different grinder models need different adaptors and spacers. Only 1 adaptor & spacer combination per machine. Please see above chart.

If your grinder model is not listed, please email your grinder brand & model number to sales@max-vac.com and we will confirm compatibility for you.

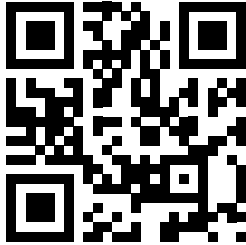
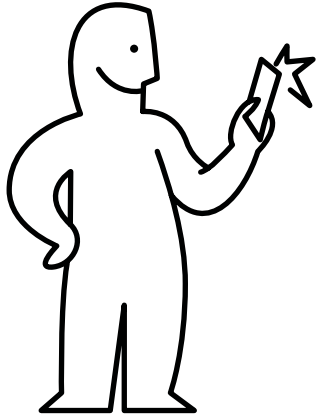

https://www.youtube.com/watch?v=MTNq_NxQi4s

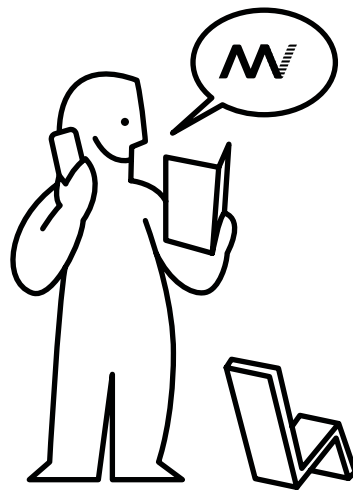
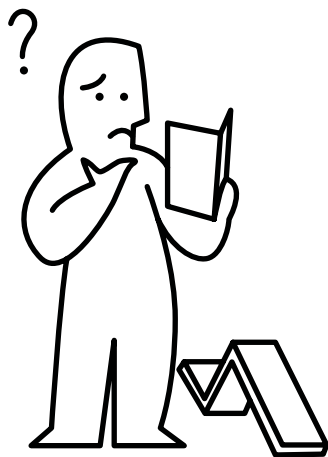

1

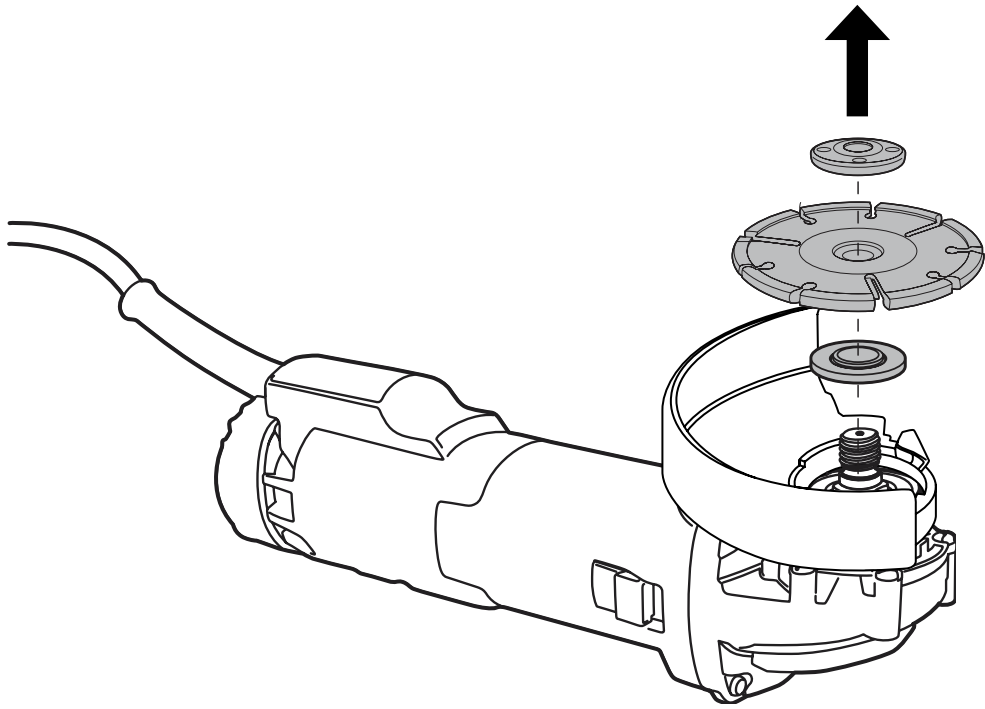

2

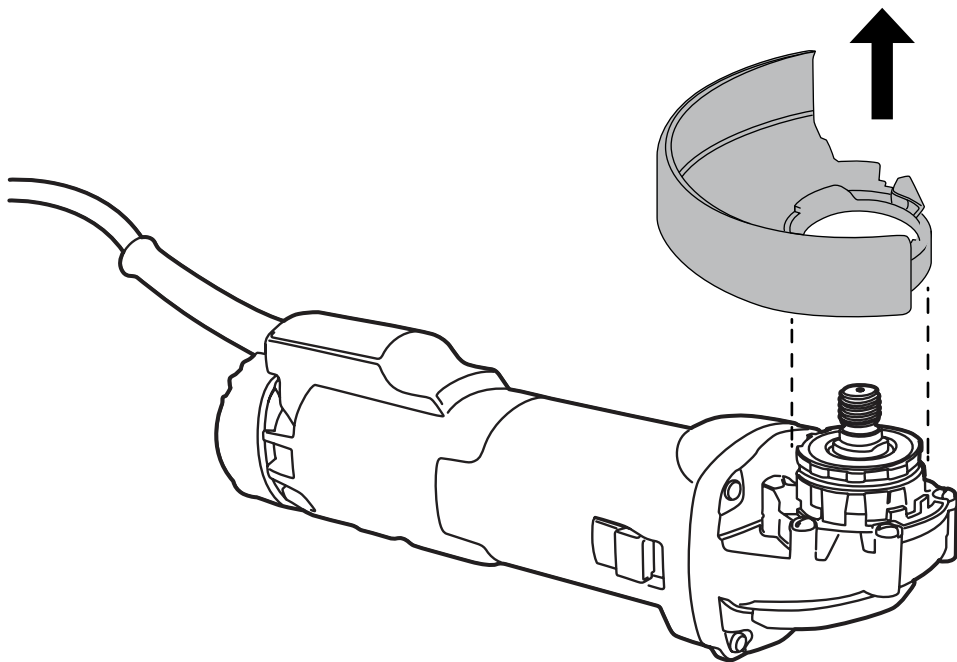

3

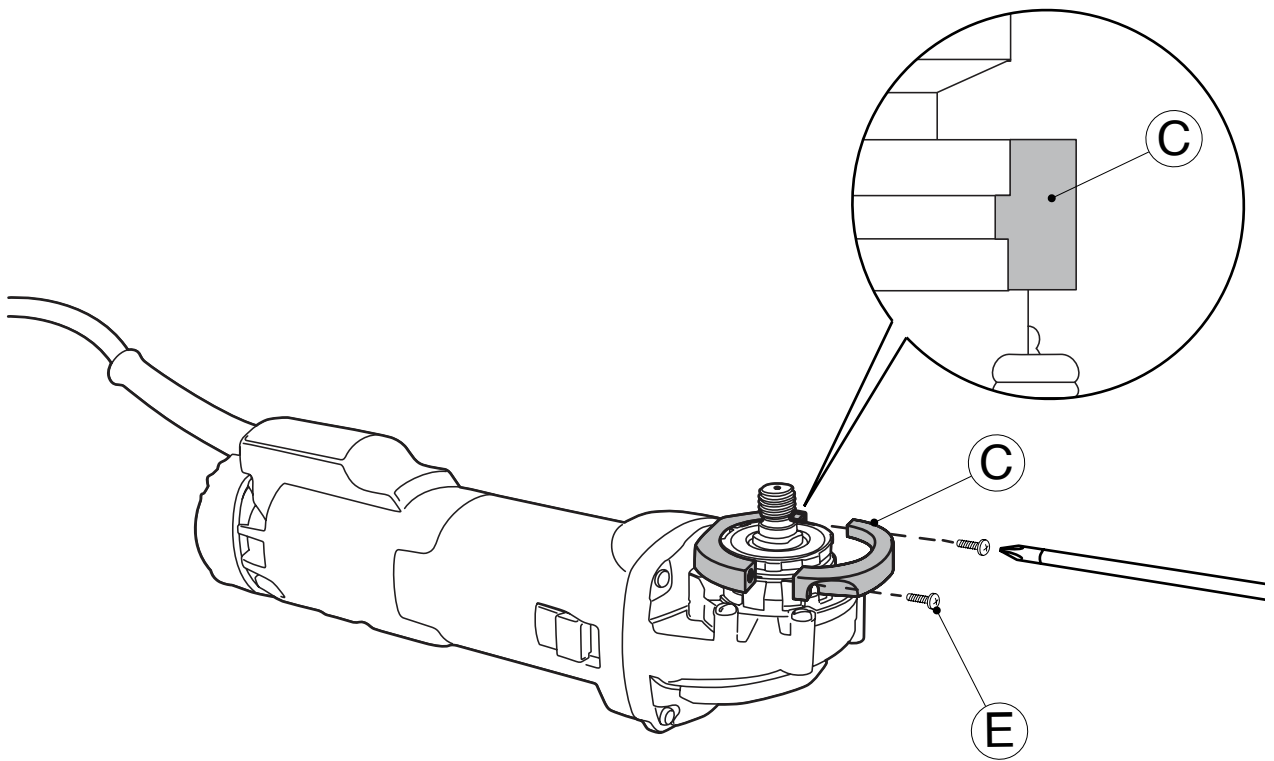
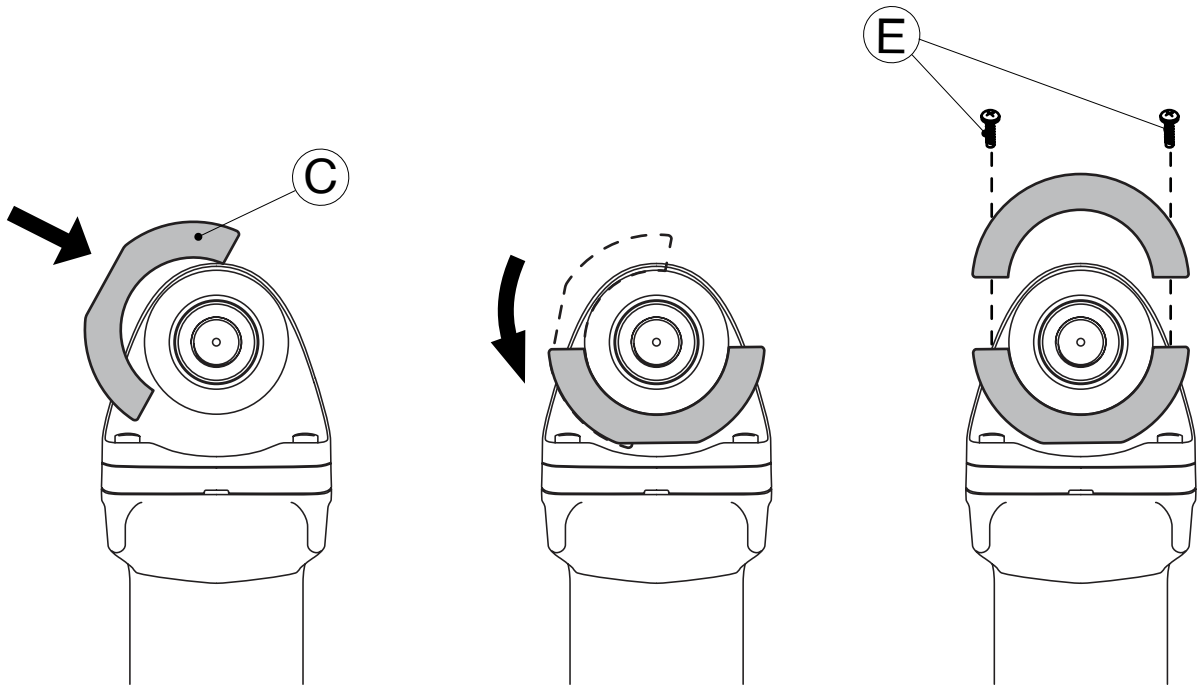

!

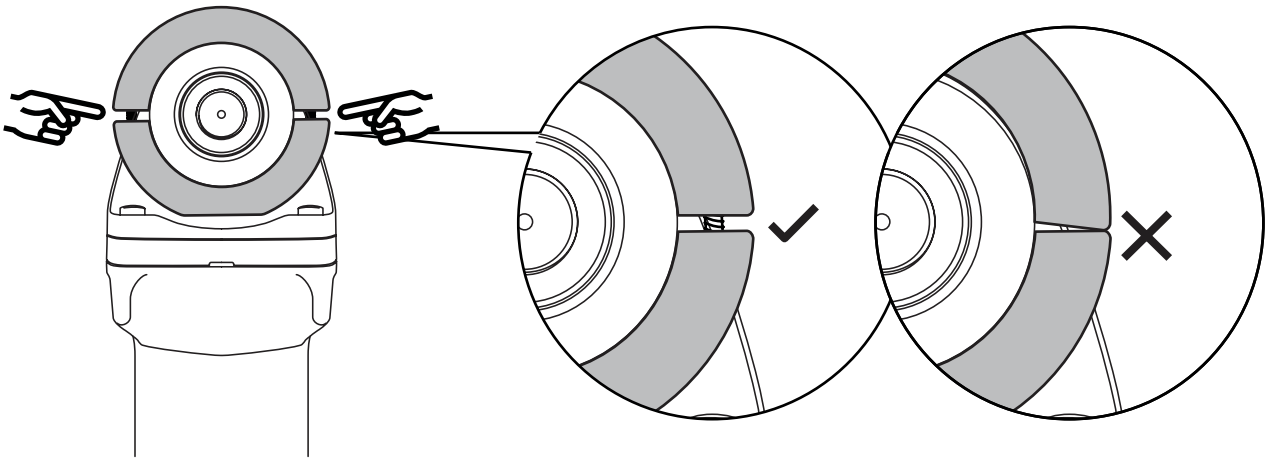

!

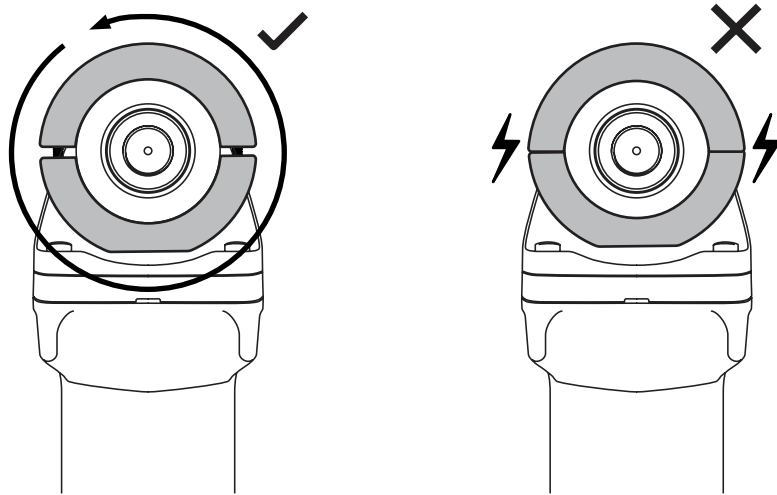

4

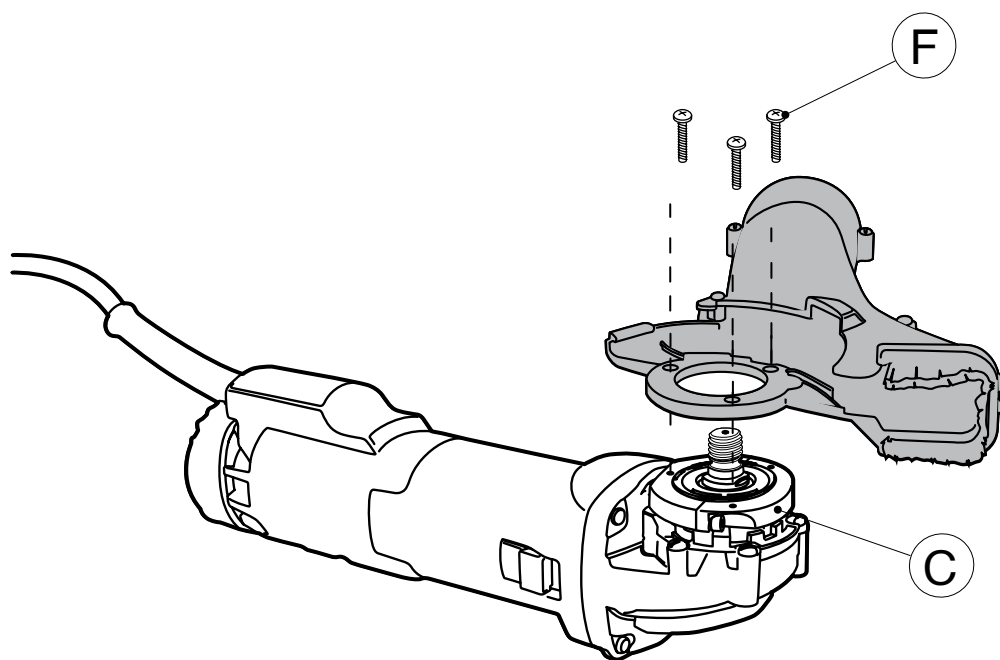

5

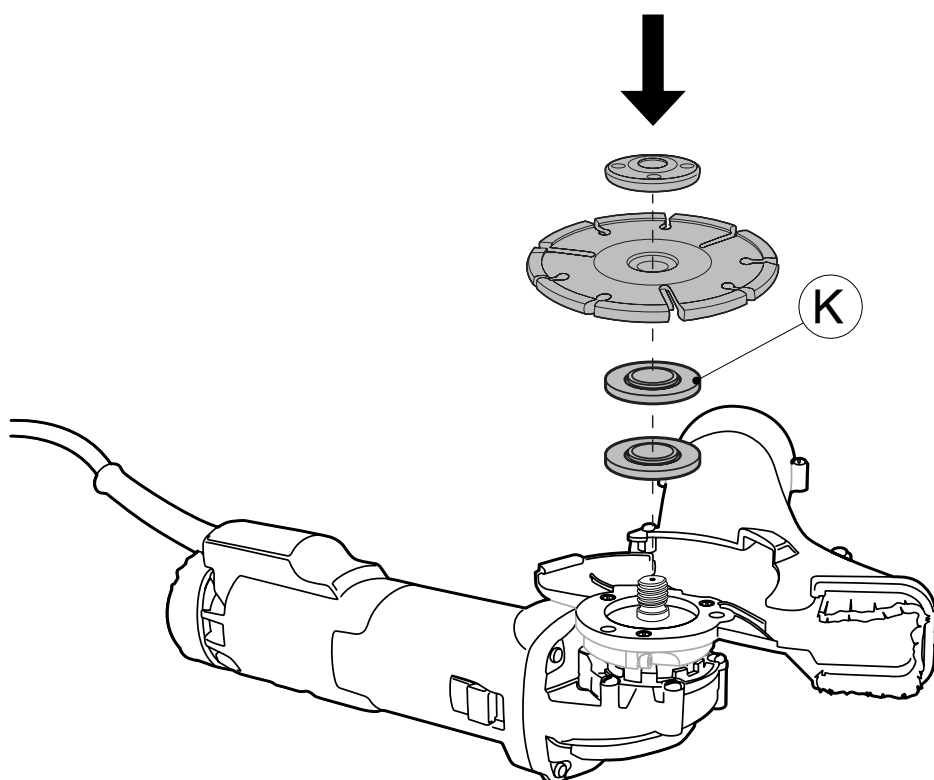

6

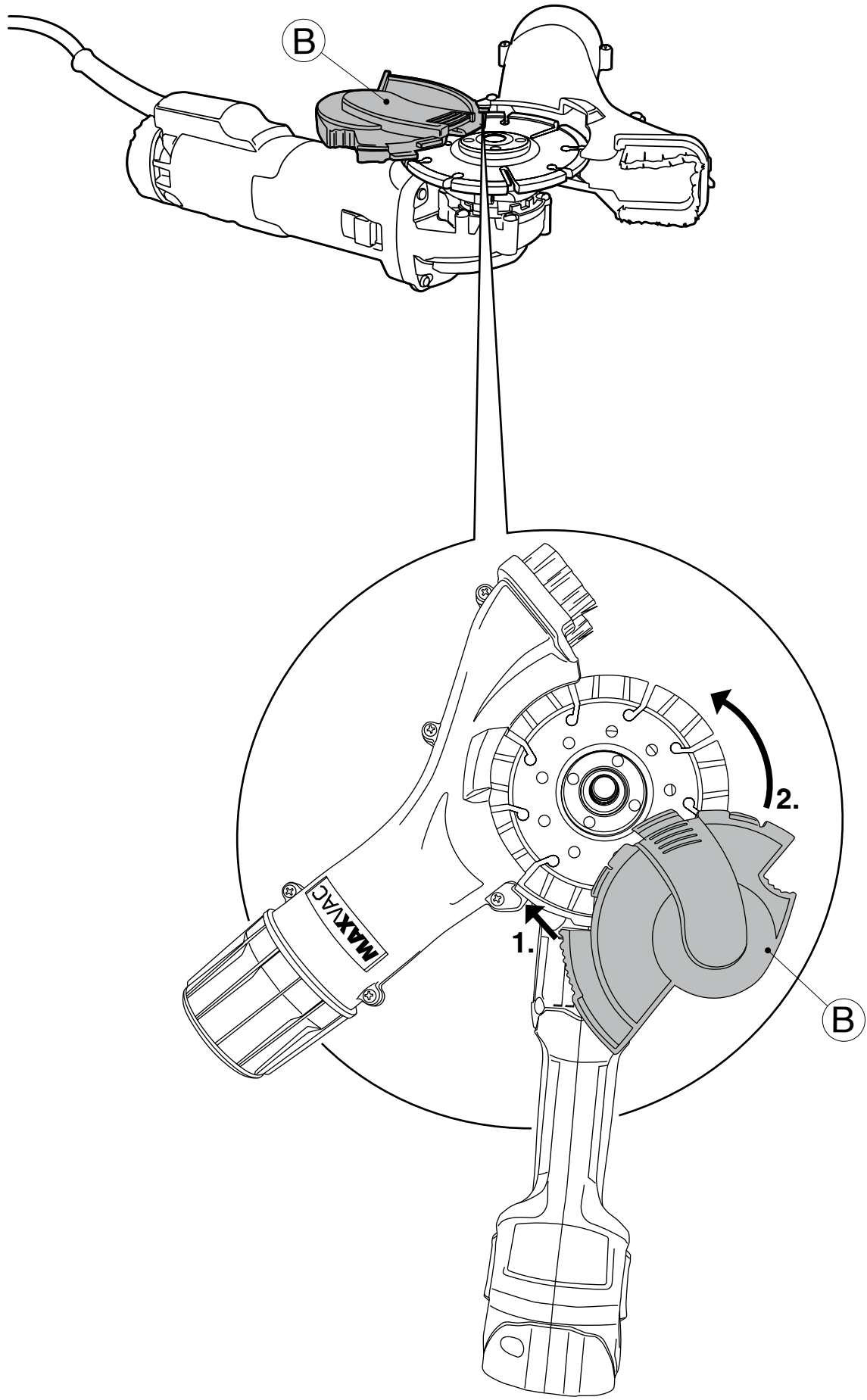

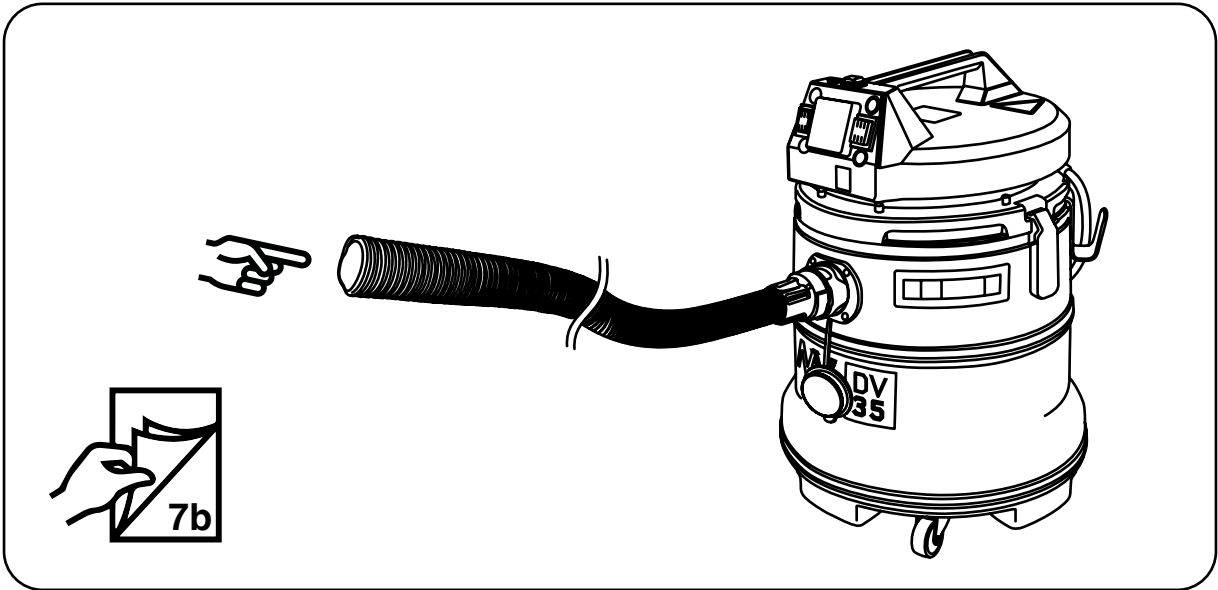
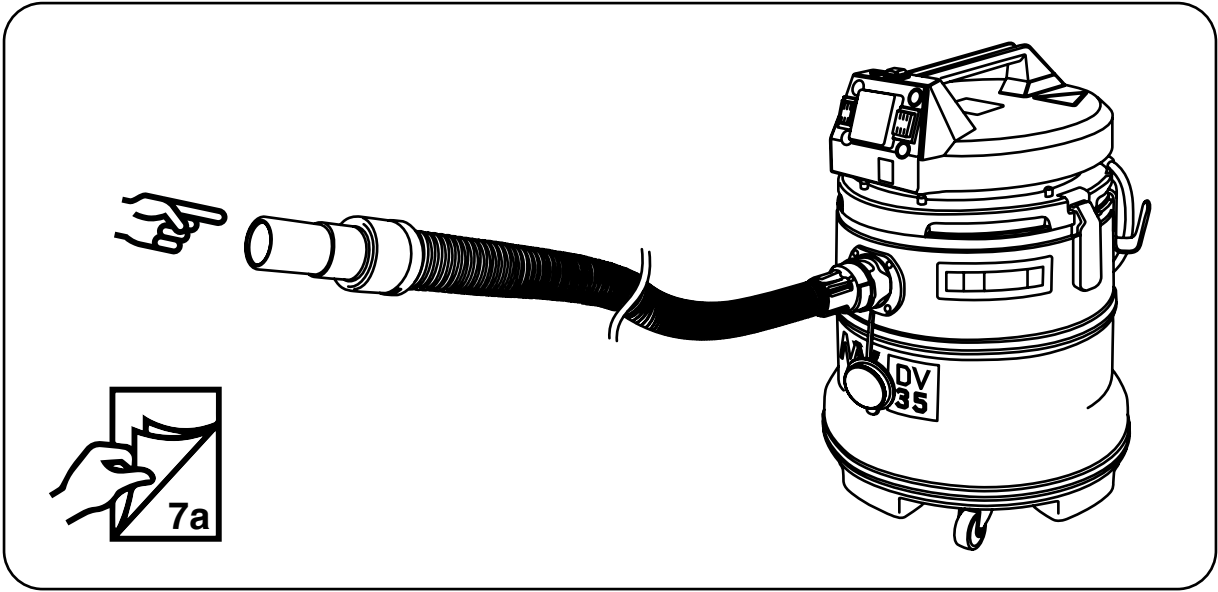

7a

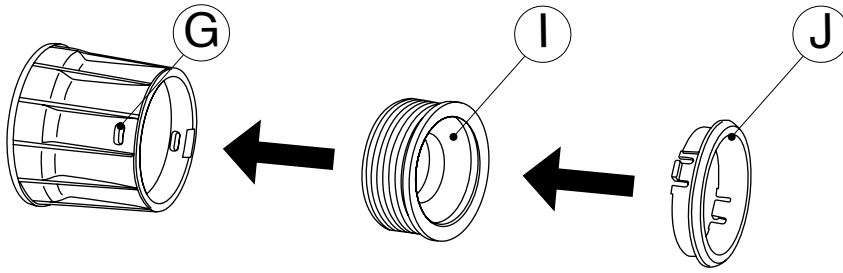

8a

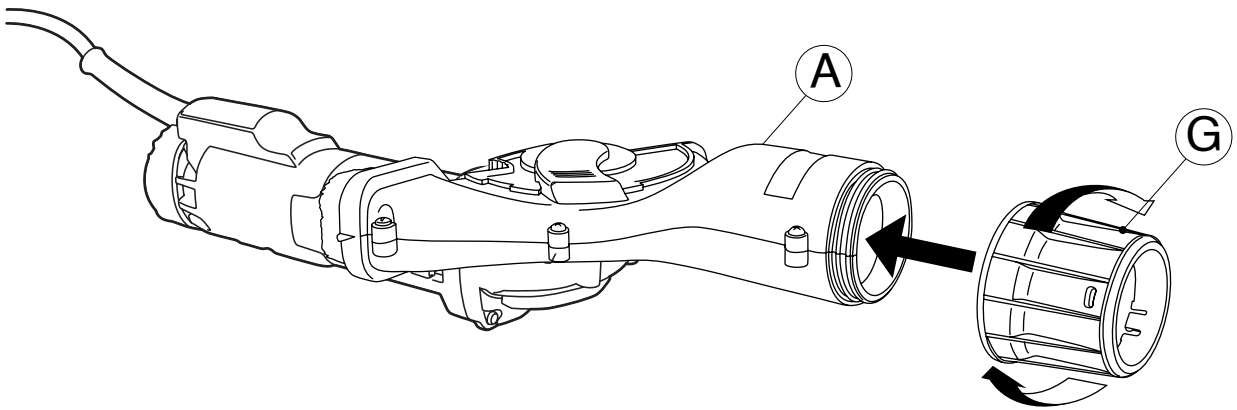

9a

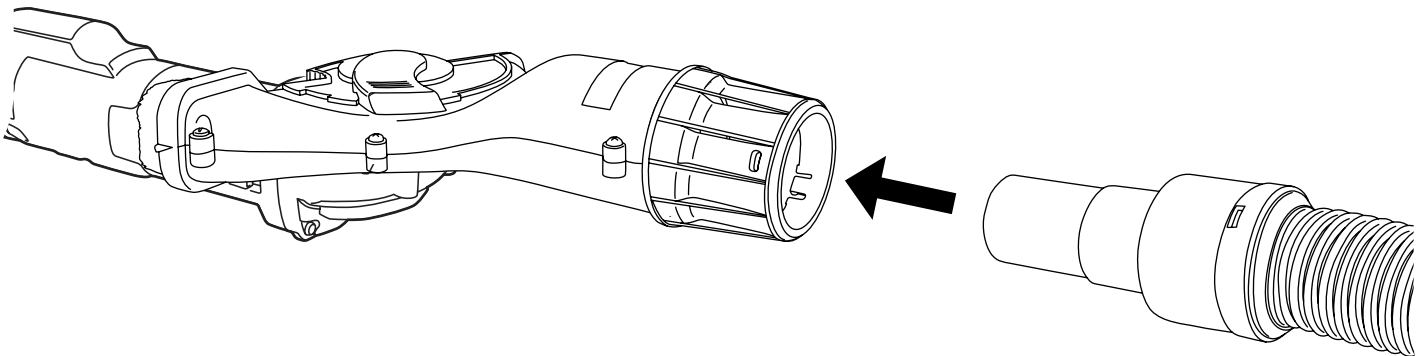

7b

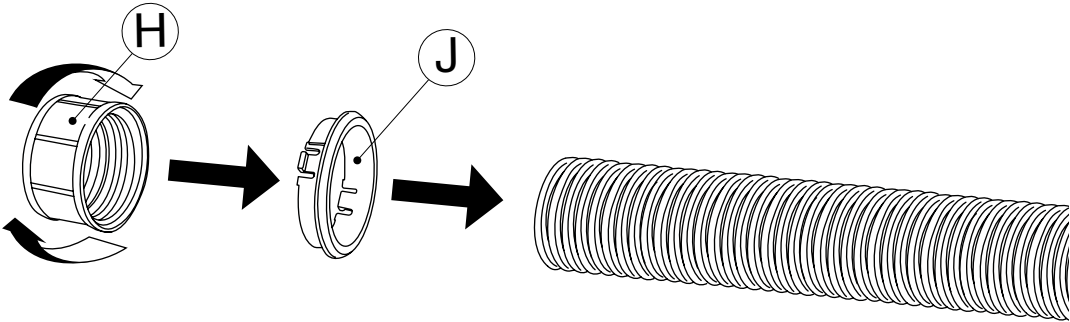

8b

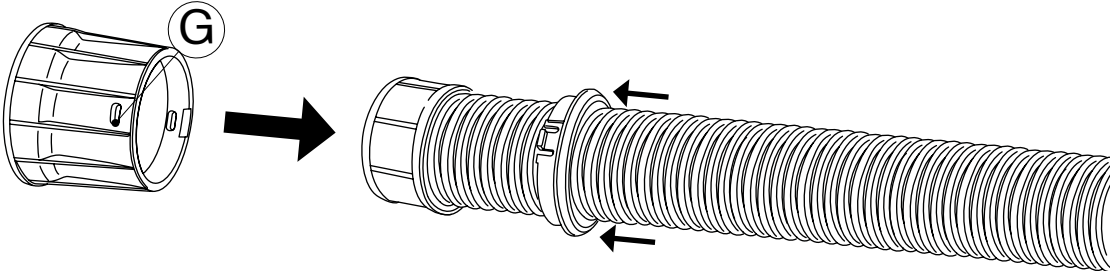

9b

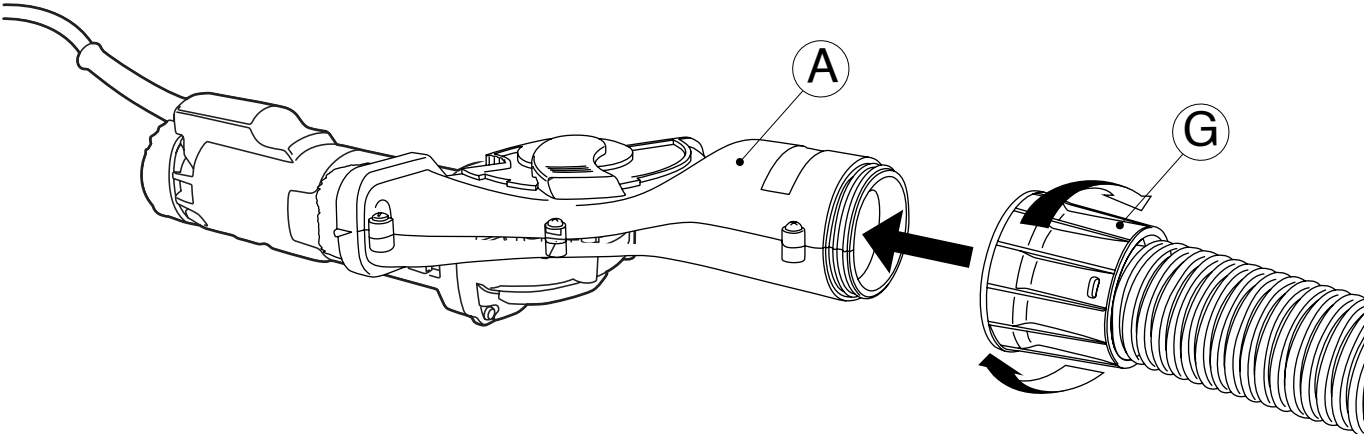

10

