



Coway Air Purifier

Airmega 250

This product is for domestic market only. Product voltage does not work overseas.
For your safety and proper use of the product, please read this user manual before use.
Warranty card is included in this user manual.

English

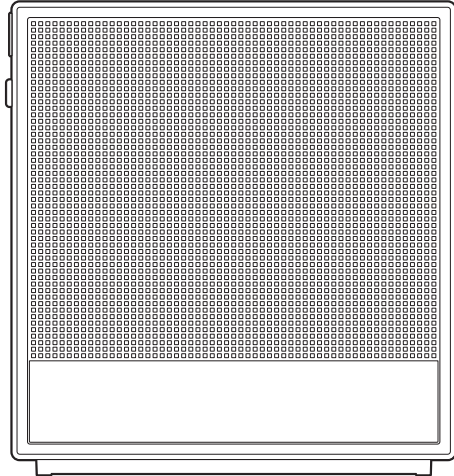

FEATURES

| Real-time Air Quality Monitoring

Airmega's pollution sensor tells you the indoor air quality in real-time. The brightly colored LED bar lets you know if your indoor air is fresh or unhealthy every minute of the day. In addition, the particle sensor classifies the particle size of the PM10 and PM2.5, and the Bar display level of air quality.

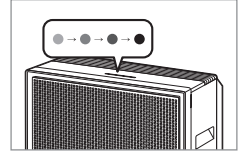

| Smart Mode

With Smart Mode, Airmega adapts to its surroundings. Fan speeds automatically adjust based on the room's air quality and room conditions.

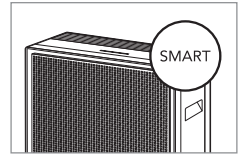

| Rapid mode

Rapid mode enables faster indoor purification. The product operates at maximum performance until the air quality is reduced to level 1.

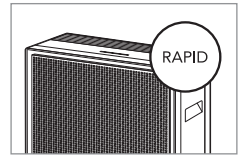

| EZ release

Coway's unique front open type was applied to the product to remove and insert a frequently cleaned pre-filter easily.

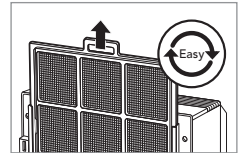

| Max2 Filter

The Max2 filter (an activated carbon filter plus Green True HEPA filter) reduces more than 99% of volatile organic compounds (VOCs), odors such as NH₃, CH₃CHO, CH₃COOH. It also captures and reduces up to 99.97% of airborne particles in the air such as pollen, pollution, and other allergens

* Filter lifetime : Approximately 12 months(based on daily 8 hours usage at max speed)

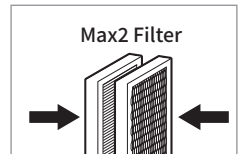

| Filter Lifetime Notifications

With status alerts for Max2 filter & the Pre-filter, you'll know when it's time to clean the Pre-filter regularly & replace the Max2 Filter. And because the Airmega gauges how much air has travelled through it, you can be sure the notifications are accurate.

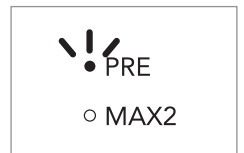

Thank you for using **Coway's air purifier.**

Please read this user manual carefully for correct use and maintenance of the product.
You can refer to the user manual to troubleshoot for product issues while using it.

| Contents

Product Information

- | 03 | Safety information
 - Danger
 - Warning
 - Caution
- | 07 | Part names
- | 09 | Air purification process

How to Use

- | 10 | Before use
 - How to install filter
- | 11 | Indicators and buttons
- | 13 | How to use
- | 15 | Adjust particle sensor
- | 16 | Cover open notification display
- | 17 | Reset filter replacement cycle

Maintenance

- | 18 | How to clean
 - How to clean product
 - How to clean filter
- | 21 | How to replace filter

Others

- | 23 | Troubleshooting
- | 24 | Specification

- Please keep the user manual in an accessible area where it can be seen. -

SAFETY INFORMATION

The following information is for user safety that should be observed.

It is to ensure user safety and prevent property damage.
Please read the precautions carefully and use the product correctly.







DANGER : Failing to follow the precautions below may result in serious injury or even death.

- ⚠ Do not use damaged power plugs or loose sockets.
- ⚠ The power plug must be plugged into 220 v – 240 v~ 50 hz, 60 hz.
- ⚠ Do not pull on the power cord to move the device.
- ⚠ Do not touch the power plug with wet hands.
- ⚠ To avoid damaging or warping the power cord, do not use excessive force to bend the power cord or put heavy objects on top of it.
- ⚠ Do not repeatedly connect and disconnect the power plug.
- ⚠ If water enters the power supply, unplug the power and completely dry before using again.
- ⚠ Be sure to unplug the power during product repair, maintenance or part replacement.
- ⚠ If the power plug's pins or contact area become covered in dust or water, wipe them thoroughly.
- ⚠ Do not plug several electric appliances into one socket, and use only a dedicated socket.
- ⚠ Unplug the power when not used for a long time.
- ⚠ Do not carelessly connect or tamper with the power cord.
- ⚠ If the power cord is damaged, do not replace it yourself. Contact a service center to have it replaced.
- ⚠ Do not put on top of electric products like heaters or televisions.











- ⚠ Do not use or store combustible gases or flammable materials near this product.
- ⚠ If there is a strange sound, burning smell, or smoke from the device, immediately unplug the power plug and contact a service center.
- ⚠ Never immerse the product in water.
- ⚠ Do not spray flammable materials such as insecticides or air fresheners on the intake.
- ⚠ Do not open, repair, or modify the device yourself.
- ⚠ Do not put bowls of water, chemicals, food, small metal objects, or flammable materials on top of this product.
- ⚠ Unplug the power before cleaning.
- ⚠ If the purifier falls over and gets wet during use, A/S maintenance is required before further use.
- ⚠ Do not spray water directly on the device or use benzene, thinners, etc. to wipe it during cleaning.
- ⚠ Do not insert sharp objects such as picks into the air quality sensor.
- ⚠ Do not put fingers or foreign matter (pins, sticks, coins, etc.) into the vent.
- ⚠ Do not let children hang from or climb on the purifier.
- ⚠ Be careful that children do not put their hands in the vent.
- ⚠ Replace the filter with a new one when the time comes.
- ⚠ Do not spray water directly on the purifier.
- ⚠ Do not place the air purifier next to Heaters.

SAFETY INFORMATION

 **WARNING** : Failing to follow the precautions below may result in considerable physical injury or property damage.

-  Do not unplug by pulling on the power cord.
-  Plug into a power socket connected to an earth leakage circuit breaker (current sensitivity 30 mA or less).
-  If extending the power cord, only use with sockets and cords of 250 V / 15 A and use by itself.

 **CAUTION** : Failing to follow the precautions below may result in slight physical injury or property damage.

-  Do not unplug the power or move the purifier while it is operating.
-  If unusual sound, odor, or smoke comes from the purifier, immediately unplug the power and call our service center.
-  Do not excessively impact or use excessive force on this product.
-  Do not use extreme force on the purifier.
-  Do not push or lean on the purifier. The purifier may fall over.
-  Do not use for a long time in places that are sealed or where children, the elderly, or sick people are.
-  Do not block the vent with laundry or curtains.
-  Remove dust from the pre-filter with a vacuum cleaner or water.
-  Periodically wash the pre-filter and dry it well in a shady place with good ventilation.
-  People with physical, sensory, or mental impairment as well as children must be supervised or guided while using the device.
-  It is advisable to supervise children so they do not play with the device.

- ⚠ This appliance can be used by children aged from 8 years and above and persons with reduced physical, sensory or mental capabilities or lack of experience and knowledge if they have been given supervision or instruction concerning use of the appliance in a safe way and understand the hazards involved.

READ AND SAVE THESE INSTRUCTIONS

PART NAMES

| Front/Rear

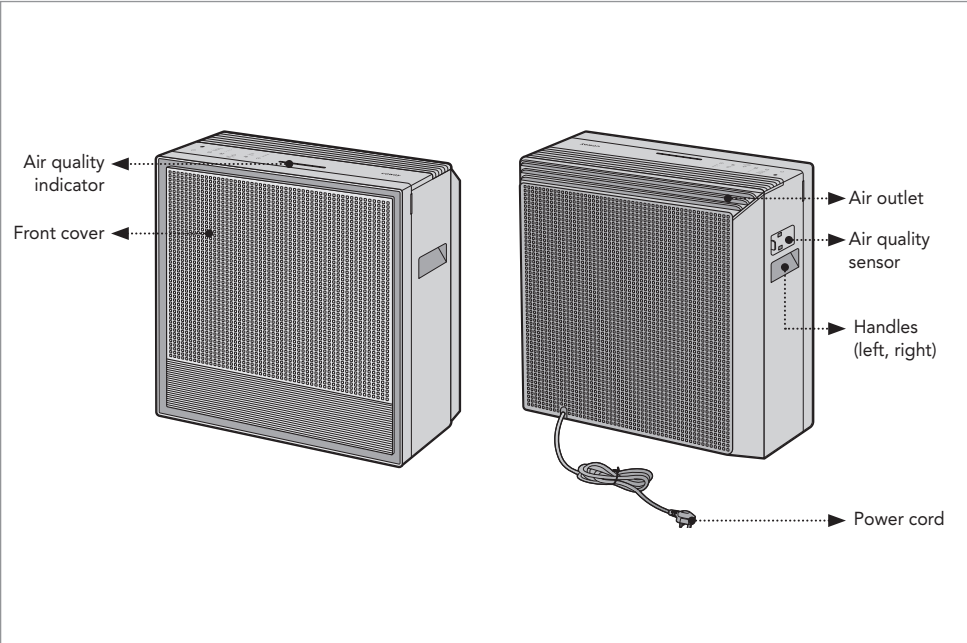

| Top

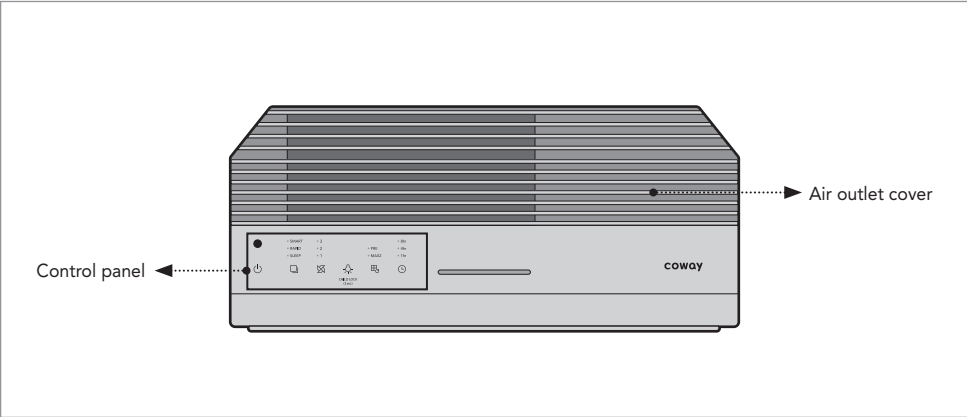

| Accessories



User Manual

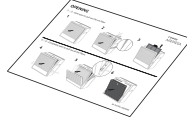

One-sheet Manual

AIR PURIFICATION PROCESS

| Pre-filter

Captures large particles like hair, fur, and dust by micro mesh.

| Max2 filter (Activated Carbon + Green True HEPA)

Captures and reduces more than 99 % of VOCs and odors such as NH_3 , CH_3CHO , CH_3COOH . It also captures and reduces up to 99.97 % of airborne particles, allergens, and contaminants down to 0.3 microns in size.

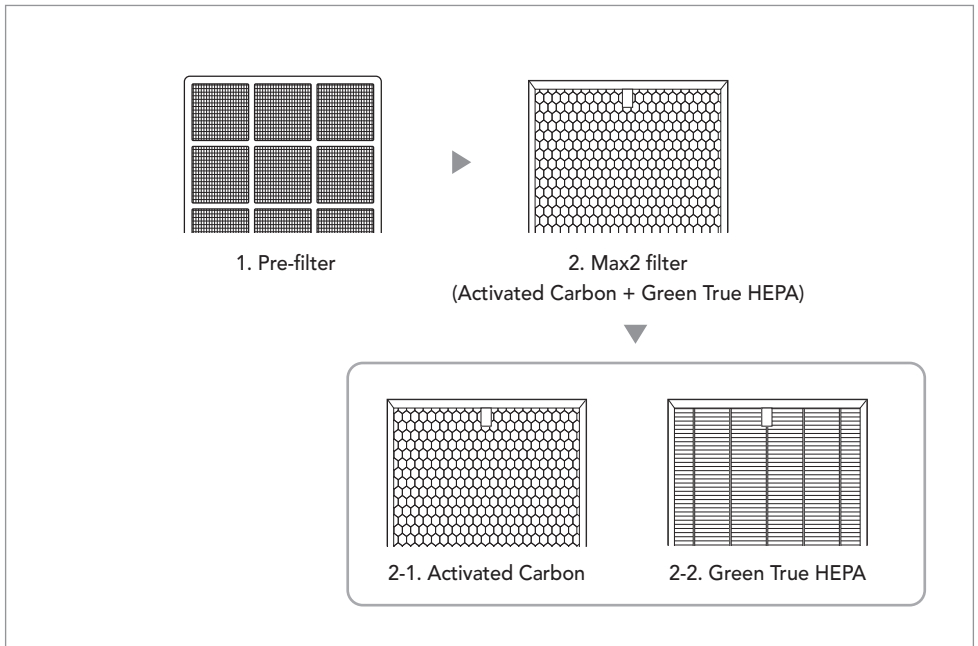

| Please check before use!

⚠ The product is for 220 V- 240 V~ 50 Hz, 60 Hz only.

The power plug must be plugged into 220 V- 240 V~ 50 Hz, 60 Hz.

| How to install filter



Tips

- Be sure to remove the packaging vinyl before installing the filter.
- Use the filter indoors only.
- Unplug the power cord from the outlet when not using the product.

▶ Filter assembly order: Max2 filter → Pre-filter

1. Open the cover located at the front of the product.

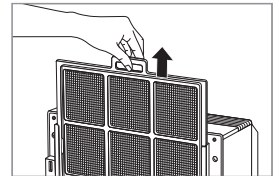
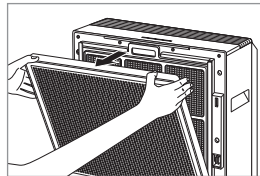

2. Take out the filter and remove the plastic packaging.

* Remove the plastic packaging from filter, excluding the pre-filter, and assemble them in the purifier in order.

* Filter assembly order :
Max2 filter → Pre-filter → Cover

* Place the Max2 filter into the filter case with the green side facing the product. Reversed placement may affect the filter lifetime.

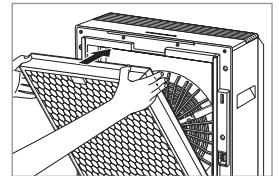
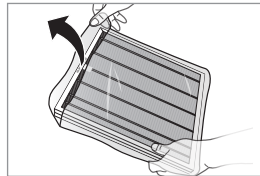

3. Return the filter and cover in reverse order at the first step.

* Fit the two tabs on the bottom part of the front cover into their slots and push to install.

* If the side cover is not properly attached, the product will not operate.

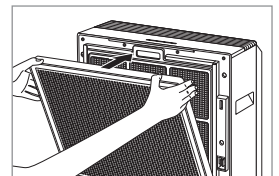
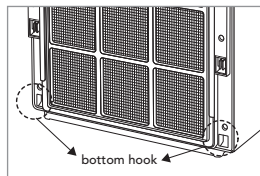

INDICATORS AND BUTTONS

| Indicators

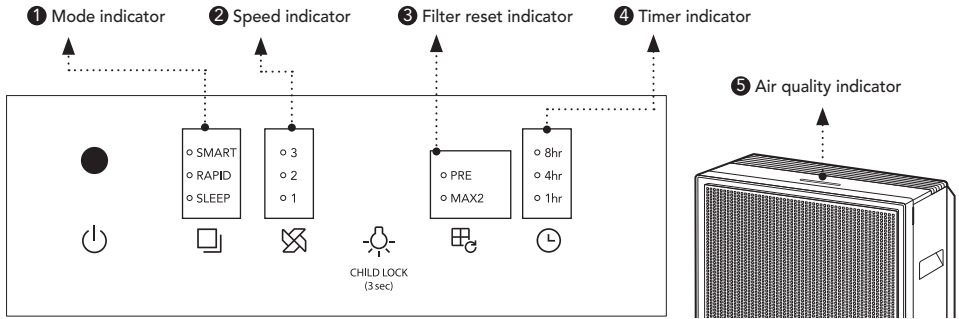

1 Mode indicator

- SMART
- RAPID
- SLEEP

Each indicator lights up when mode is selected.

2 Speed indicator

- 3
- 2
- 1

The indicator is turned on when the speed level 1 / level 2 / level 3 is selected.

3 Filter reset indicator

- PRE
- MAX2

The indicator stays on during the filter cleaning/replacement cycle. When the cleaning cycle or life becomes less than 2%, the corresponding indicator will emit an orange color light.

4 Timer indicator

- 8hr
- 4hr
- 1hr

When the timer is selected, the timer indicator lights up.

5 Air quality indicator

This indicator displays the indoor air quality in LED colors.

Good (blue) → Moderate (green) → Unhealthy (yellow) → Very unhealthy (Red)

Buttons

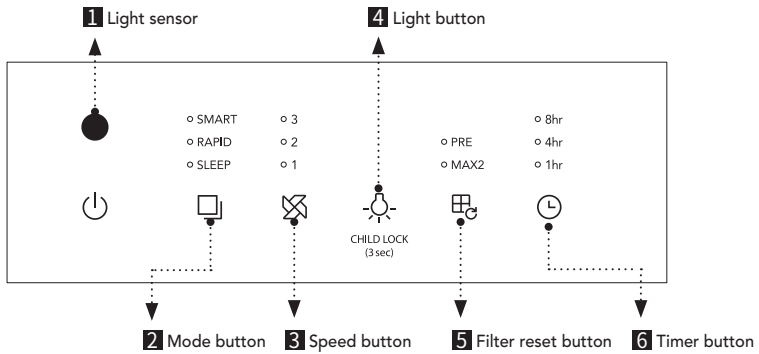

1 Light sensor
This sensor detects light around the product.

2 Mode button
Press the mode button to select the smart mode → rapid mode → sleep mode.

3 Speed button
Press the speed button to select the level 1 → level 2 → level 3.

4 Light button
Use this button to turn on and off the indicator and air quality indicator. If you press the [Light] button while all indicators and the air quality indicator are turned on, you can turn on and off the indicators in the following order: Air quality indicator off → all indicators off → all indicators on.

5 Filter reset button
When the filter replacement indicator is turned on, press the corresponding button for more than 3 seconds after cleaning and replacing the filter.

6 Timer button
Press the timer button to set the timer.

- * If both indicators(PRE and MAX2) turn on at the same time, the filters can be reset at once.
- * If the filter replacement indicator is not turned on, the related button functions do not operate.
- * If you have replaced or repaired the filter before the filter replacement indicator was turned on, refer to page 21.
- * The cleaning and replacement cycle of the pre-filter and combined filter is recommended and may vary depending on the use environment.

HOW TO USE



Tips

- Before operating the product, insert the power plug into the outlet.
- When the product is turned on, it operates in automatic mode by default.

| Smart Mode

Press the [Mode] button to select the smart mode.

If the product is set to Smart mode, it automatically adjusts the air speed according to the current air quality around the product. The air speed is adjusted as shown in the table below:

When set to Smart Mode, if the pollution level remains Good(Level 1) for more than 10 minutes, the fan stops automatically to conserve energy. If the product detects air pollution, the fan will automatically restart again. Also, if the ECO mode maintains for 30 minutes, the fan will restart as well. If the pollution level remains Good for more than 10 minutes after restarting, the ECO mode will be activated again.

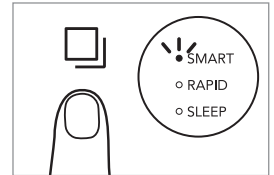

Air Quality	Good	Moderate/unhealthy	Very unhealthy
Air Speed	Level 1	Level 2	Level 3

| Sleep Mode

Press the [Mode] button to select the sleep mode. This mode minimizes the speed during operation for a quiet and pleasant environment.

If the product is set to Smart mode, Sleep mode is activated automatically, so that it can reduce noise and power consumption. It activates when the room is dark and the air quality is Good(Level 1) for 3 minutes.

If the light sensor detects light for 5 minutes or longer and/or if the air quality level in the room is Moderate(Level 2) or worse. The Smart mode will activate automatically.

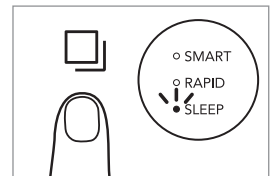

| Rapid Mode

Press the [Mode] button to select rapid mode.

When the air quality is maintained at level 1 for more than 5 minutes, it is switched to the smart mode. When the product continues to operate for more than a maximum of 60 minutes, it is switched to the smart mode.

* The maximum fan speed in the rapid mode is the same as level 3.

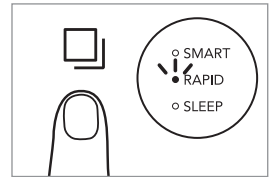

| Setting the Timer

Touch the [Timer] button until the indicator light displays the desired time.

You can set the product to automatically turn off after an hour, 4 hours, or 8 hours. Use this feature to save energy when you leave home or go to bed.

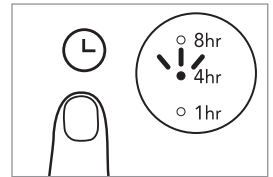

| Checking the Air Quality

Air quality indicator

This indicator displays the indoor air quality in LED colors.

Good (blue) → Moderate (green) → Unhealthy (yellow) → Very unhealthy (Red)

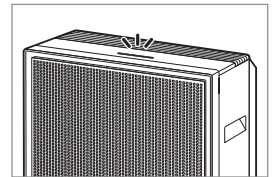

ADJUST PARTICLE SENSOR

| How to adjust the sensitivity of the particle sensor

When the product is shipped out, the pollution sensor is set to standard sensitivity. If the pollution level stays at the highest level after 2 hours of operation or stays at the lowest level for more than 1 hour when the air does not seem clean, users can adjust the sensitivity of the pollution sensor as follows.

1. While the product is operating, press the [Mode] button and the [Speed] button at the same time for more than 2 seconds.

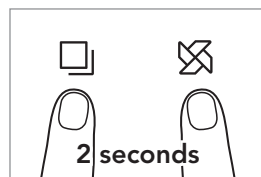

2. The speed indicator blinks to display the current sensor sensitivity level.

* Initial sensor sensitivity is at the normal level.

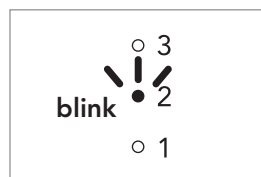

3. Press the [Mode] button to adjust it to the desired sensitivity. The mode indicator blinks as shown below once sensor sensitivity has been selected.

1	2	3
Sensitive	Normal	Less sensitive

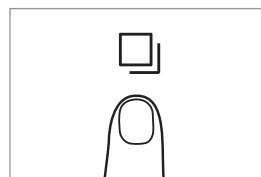

4. Press the [Mode] button and the [Speed] button at the same time for more than about 2 seconds, the selected sensitivity will be inputted and the product will start operating normally.

* If the [Speed] button are not pressed for 10 seconds, the selected sensitivity of the sensor is automatically entered.

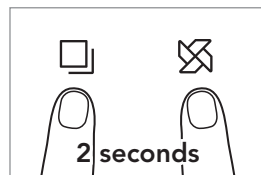

| Cover Open Notification Display

When the front cover is detected open for more than 2 seconds, all indicators will turn off and the product stops all operation. When the front cover is detected closed for more than 1 second, the product returns to the previous operation mode.

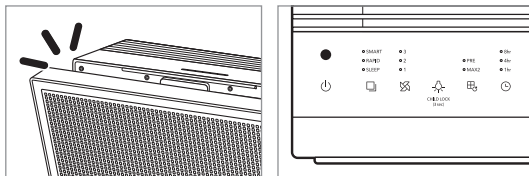

| Reset The User-Selected Filter Replacement Cycle

This instruction is a guide for the next filter replacement maintenance. The filter replacement and cleaning cycle selected by the user when the user replaces or cleans a filter by themselves before the filter replacement notification is displayed.

1. Press the [Filter reset] button and [Light] button at the same time for more than 2 seconds.

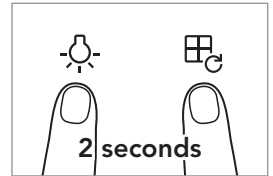

2. The Pre-filter indicator will start blinking. Then press the [Filter reset] button to select the filter that needs to be replaced or cleaned.

* A filter is selected in the following order. Pre-filter → Max2 filter → Pre-filter & Max2 filter → Pre-filter

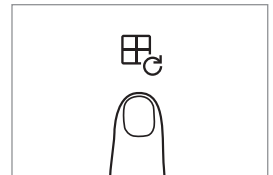

3. If you press the [Filter reset] button for more than 2 seconds, the selected filter option will reset.

* If you do not reset the filter and press the [Light] button and the [Filter reset] button again at the same time for about more than 2 seconds, or if you do not press the [Mode] button or the [Filter reset] button for 10 seconds, the filter is automatically canceled.

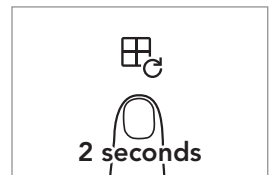

- If you replaced or managed the filter before a filter replacement alarm is displayed, reset the filter replacement cycle using the user-selected filter replacement cycle reset function.
- Adjusting the sensitivity of air quality sensor and resetting the user-selected filter replacement cycle have the same entering and canceling method.



Tips

- Always unplug the power cord before cleaning.
- Do not use organic solvents (thinner, etc.), bleach, or detergents containing chlorine or abrasives to clean the product.
- Do not immerse the product in water or spray water on it.
- The cleaning / maintenance cycle may differ depending on use environment.

| Cleaning the pollution Sensor (every 2 months)

1. Use a soft brush or vacuum cleaner to clean the air inlet and the air outlet of the air quality sensor.

* Be careful not to let dust fall inside the product when cleaning.

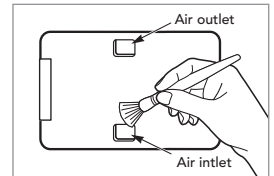

2. Open the air quality sensor cover on the right-hand side of the product. (by using the hole on the air quality sensor cover.) Wet a cotton swab lightly and clean the lens, dust inlet, and dust outlet. Clean them with a dry cotton swab to remove the remaining moisture.

* Without regular cleaning, the performance of the air quality sensor deteriorates.

* When using the product in a dusty environment, clean the sensor more often.

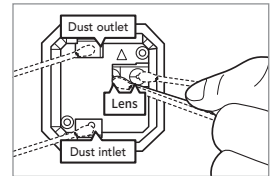
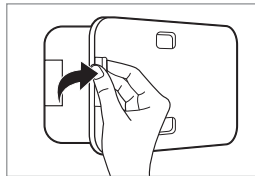

| Cleaning the air outlet

1. Lift up the detachable air outlet grille mounted on top of the air outlet.

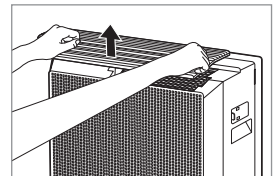

2. Clean the grill and the air outlet using a soft brush or vacuum cleaner.

* Do not let dusts drop into the air outlet when you clean it.

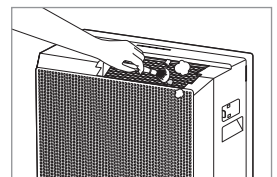

HOW TO CLEAN

| Cleaning the front cover

Remove the front cover from the purifier and then wipe away dust stuck to the surface with a soft, dry cloth or soft brush.

* Do not use abrasive.

* Clean the front covers frequently for optimum performance.

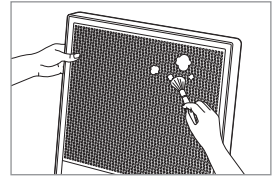

| Cleaning the exterior

Wipe the exterior of the product with a soft dry cloth.

* When the exterior is dirty, use a slightly damp cloth.

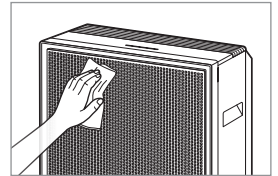



Tips

- Always unplug the power cord before cleaning the filter.
- The pre-filter can be restored by removing dust or washing with water.
- Failure to clean the pre-filter for a long time may result in poor product performance.
- Max2 filter cannot be restored by cleaning.
Never wash these filters with water.

Pre-filter

When the [Pre Wash] indicator is on, clean your pre-filter on front. Follow these instructions below to clean the filter.

1. Open the front cover by pulling out the top part of it.

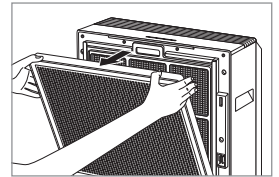

2. Pull the pre-filter upward to take it out.

* Be careful not to let dust fall off when removing.

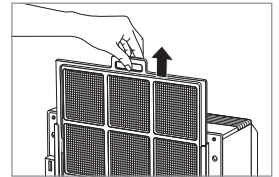

3. Remove dust with a vacuum cleaner or water depending on the degree of pollution.

* Be careful not to let dust fall inside the product when cleaning.

* If you use water to clean the pre-filter, dry the pre-filter in the shade before re-installing it.

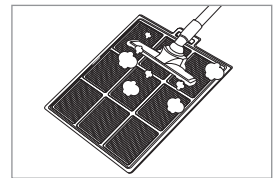

4. Push in the dried pre-filter inside the product all the way to install. Close the side cover again.

* When assembling the pre-filter, press the hooks on both sides completely.

* And touch and hold the [Filter reset] button refer to 17 page.

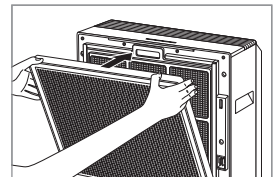
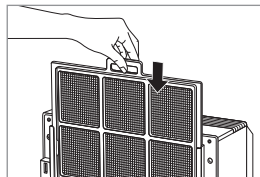

HOW TO REPLACE FILTER

| How to replace filter

- Refer to the filter installation method on page 10 to replace the filter.
- Use genuine Coway filter to maintain optimal performance of the product.
- Always unplug the power cord before replacing the filter.

| Filter cleaning and replacement cycle

Filter	Cleaning/Replacement time	Cleaning/Replacement
Pre-filter	Cleaning the filters whenever the filter indicator is on	Clean and wash
Max2 filter	Replacing the filters whenever the filter indicator is on	Replacement

* A filter cleaning/replacement cycle may differ by use environment.



Tips

- The cover with the filter attached may damage if it is dropped while moving, so do not move it upside down.
- Pre-filter, Max2 filter are consumables.

How to replace Max2 filter

When the [MAX2] indicator is on, please replace it.



1. Turn off the product first and remove the front cover from the product.

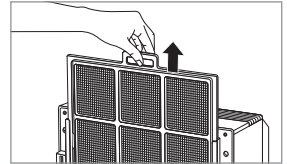
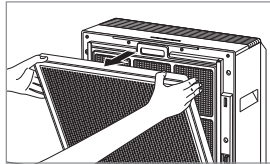

2. Move to a space where filter replacement is possible and remove the Max2 filter.

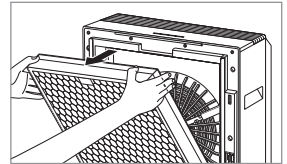

3. After cleaning the parts except the filter, attach a new filter.

* Check the direction of the arrow on the filter.

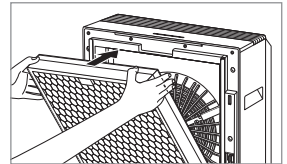

4. After assembling the product, close the front cover.

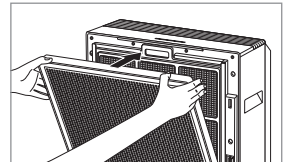
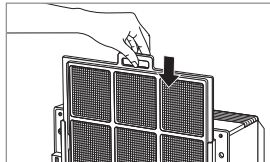

5. Please turn on the product.
Press the filter reset button for 3 seconds to reset the alarm.

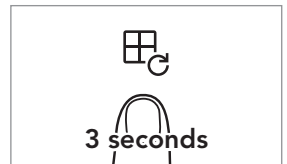
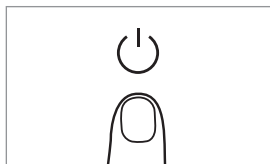

TROUBLESHOOTING

The air purifier may malfunction due to lack of familiarity and minor causes even though the product is not broken. Check the following in such a circumstance to resolve the issue easily without assistance from the service center. If the problem persists after checking the items below, please contact the service center.

Symptom	Checkpoint	Measures to take
No air is coming out.	• Is the power cord plugged in?	Plug the power cord into a 220 V- 240 V~ 50 Hz, 60 Hz outlet.
	• Are all the indicators off?	Press the Power button and select the desired function.
	• Is there a power outage?	Use the product after the electricity is restored.
The air volume does not change.	• Is the Auto Mode indicator on?	Air volume selection is available only in Manual Mode (normal).
	• Is the Silent Mode indicator on?	Air volume selection is available only in Manual Mode (normal).
The air volume has weakened considerably.	• Has the filter cleaning or replacement time passed?	Check the filter cleaning and replacement cycle and clean or replace the filter.
The pollution level does not change.	• Is there dirt on the pollution sensor lens?	Clean the pollution sensor lens. (Refer to P. 18.)
	• Does the pollution level remain at High?	Adjust the pollution sensor's sensitivity to Low or Standard. (Refer to P. 17.)
	• Does the pollution level remain at Low?	Adjust the pollution sensor's sensitivity to High or Standard. (Refer to P. 17.)
There is a bad smell coming out of the air outlet.	• Has the filter cleaning or replacement time passed?	Check the filter cleaning and replacement cycle and clean or replace the filter.
The pollution level indicator is flashing.	• Contact the service center.	
Other functional defects	• Check the problem, unplug the power cord, and contact the service center.	

Product name	Air purifier
Model name	Airmega 250
Rated voltage	220 V- 240 V~ 50 Hz, 60 Hz
Phase	Single phase
Power consumption	60 W
Product insulation class	Class 2 equipment <input type="checkbox"/>
Dust collection method	Washable Pre-filter + Max2 filter set (Activated Carbon + Green True HEPA)
Installation location	For indoor use
Product dimensions	470 mm (width) × 204 mm (length) × 501 mm (height)
Product weight	10 kg

- Product design and specification may change without any prior notice for application of statutes, product improvement, and quality enhancement.

**WARRANTY CARD OR WARRANTY LETTER
TWO YEAR LIMITED WARRANTY
AIR PURIFIER Airmega 250(“PRODUCT”)**

Model:

Serial Number:

Customer Name:

(“OWNER”)

Date of Purchase:

What This Warranty Covers:

Commencing with the date of purchase of the Product and continuing for a period of Two years, if manufacturing defects in the Product cause the Product to not operate properly for its intended use, then subject to the exclusions, conditions, and limitations contained herein, COWAY at its sole option will repair or replace the Product.

Decisions as to the extent of repair or replacement required will be made solely by COWAY.

The remedy under this Warranty is available only for that portion of the Product exhibiting defects at the time of the warranty claim. The replacement Product as well as any remaining original Product will be warranted only for the original two years warranty period. This limited warranty applies only to Product used for an application specified by COWAY for the Product and applied in strict accordance with COWAY published specifications in effect at the time of application. IF PRODUCT IS USED FOR OTHER THAN ITS INTENDED PURPOSE, IT IS SOLD AS IS AND WITHOUT ANY EXPRESS

OR IMPLIED WARRANTIES, INCLUDING OF MERCHANTABILITY OR FITNESS FOR A PARTICULAR PURPOSE.

What This Warranty Does Not Cover:

This Warranty warrants that the Product will be free from manufacturing defects which affect the ability of the Product to operate for its intended use; it is not a warranty that the Product will never require repairs or to undertake responsibilities, liabilities or obligations other than those specifically identified in the preceding section. COWAY is not responsible or liable for personal injury or property damage of any kind, even if arising from a breach of this Warranty.

Limitations and Exclusions:

TO THE EXTENT PERMITTED BY APPLICABLE LAW, COWAY DISCLAIMS ANY OTHER WARRANTY EXPRESS OR IMPLIED, THAN THAT PROVIDED FOR HEREIN. THIS WARRANTY IS IN LIEU OF AND EXCLUDES ALL OTHER WARRANTIES, GUARANTEES, CONDITIONS AND REPRESENTATIONS, EXPRESS OR IMPLIED, ORAL OR WRITTEN, STATUTORY OR OTHERWISE, INCLUDING BUT NOT LIMITED TO ANY IMPLIED CONDITIONS OR WARRANTIES AS TO THE MERCHANTABILITY OR FITNESS FOR A PARTICULAR PURPOSE OF THE COWAY PRODUCT. SOME STATES DO NOT ALLOW LIMITATIONS ON HOW LONG AN IMPLIED WARRANTY LASTS, SO THE ABOVE LIMITATION MAY NOT APPLY TO YOU. COWAY DOES NOT AUTHORIZE ANY PERSON INCLUDING ITS REPRESENTATIVES, TO MAKE ANY REPRESENTATION OR TO OFFER ANY WARRANTY, CONDITION OR GUARANTY IN RESPECT OF THE PRODUCT OTHER THAN THIS WARRANTY. THIS LIMITED WARRANTY SHALL BE THE OWNER'S SOLE AND EXCLUSIVE REMEDY AGAINST COWAY AND COWAY SHALL NOT BE LIABLE FOR ANY CONSEQUENTIAL, EXEMPLARY, SPECIAL, INCIDENTAL OR OTHER DAMAGES INCLUDING, BUT NOT LIMITED TO, LOSS OF PROFITS, AND LOSS OF USE. INCIDENTAL, CONSEQUENTIAL AND EXEMPLARY DAMAGES SHALL NOT BE RECOVERABLE EVEN IF THE REMEDIES OR THE ACTIONS PROVIDED FOR IN THIS WARRANTY FAIL OF THEIR ESSENTIAL PURPOSE. SOME STATES DO NOT ALLOW THE EXCLUSION OR LIMITATION OF INCIDENTAL OR CONSEQUENTIAL DAMAGES, SO THE ABOVE LIMITATION OR EXCLUSION MAY NOT APPLY TO YOU. COWAY SHALL NOT BE LIABLE FOR ANY DAMAGES WHICH ARE BASED UPON NEGLIGENCE, BREACH OF WARRANTY, STRICT LIABILITY OR ANY OTHER LEGAL THEORY OF LIABILITY OTHER THAN THE EXCLUSIVE LIABILITY SET FORTH IN THIS WARRANTY.

Limitations on Implied Warranties:

Any implied warranty of merchantability or fitness for a particular purpose or use, shall be limited to the duration of the foregoing express written warranty.

Conditions of Warranty:

COWAY's continuing liability under this Warranty is conditioned upon the following:

- a) The defect or damage is not caused by or is the result of: abnormal use or conditions; improper storage, unauthorized modifications or repair; misuse, neglect, accident, alteration, improper installation or other acts that are not the fault of Coway or the manufacturer of the product or that are not covered by the manufacturer's warranty;
- b) The Product has not been altered, modified or repaired without prior written approval of COWAY;
- c) The OWNER has notified COWAY in writing of any failure of the Product covered by this Warranty within thirty (30) days following such failure;
- d) There has been no misuse, abuse or negligence with respect to the Product on the part of the OWNER.

Waiver:

COWAY's failure at any time to enforce or rely upon any of the terms or conditions stated herein shall not be construed to be a waiver of its rights hereunder.

Obtaining Warranty Service and OWNER'S Duties:

If the Product fails to operate for its intended purpose, then notify COWAY or its Representative Agency, within 48 hours or within the next business day after discovery of any defect in the Product. The OWNER must give written notice to COWAY no later than thirty (30) days after a defect is discovered or should by reasonable diligence have been discovered. Claims under this Warranty will require proof of purchase by the OWNER

AUSTRALIA
ABN : 92 995 764 645 Tel. : 1300 057 346 (9am-6pm, Mon-Fri, AEST) Mail : cowaymega_au@coway.com Web : au.coway.com

COWAY
Add : COWAY Co., Ltd. 136-23, Yugumagoksa-ro, Yugu-eup, Gongju-si, Chungcheongnam-do, Korea Tel. : Korea-Seoul : +82-1588-5200

INDIA
Add : 701B Tower B, One BKC, Bandra Kurla Complex Bandra East, Mumbai - 400051 Tel. : 1800-102-6960 Mail : info@cowayindia.in

002

9241807

coway

www.coway.com