

Catalogue

- Applicable size.....01
- Product components.....03
- Accessories list (TOOL BOX).....04
- Install battery
- Adjust the length of the cylinder.....05
- Installation pictures/video
- Uresetting diagram
- Setting operation.....06
- Unlock and lock.....08
- Bluetooth activation and login instructions.....09
- Select "Android/iOS" to download
- Log in to the app
- Bind the device.....10
- Specifications.....11
- FAQ

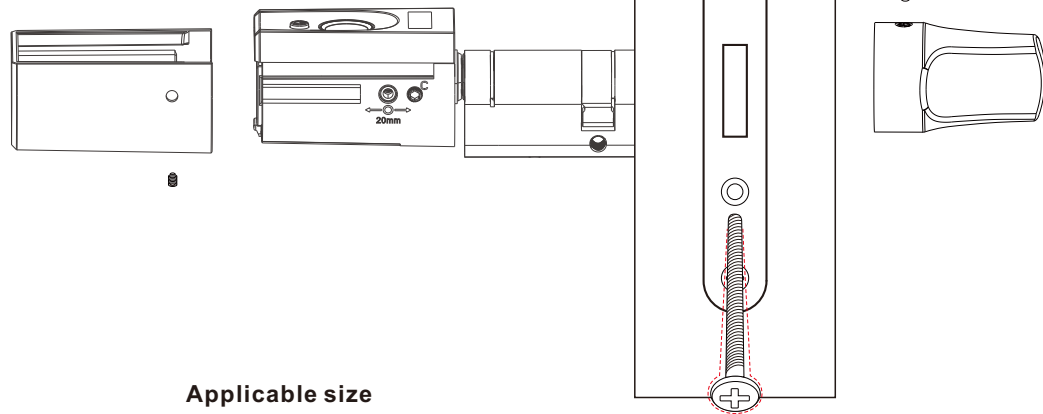

Applicable size

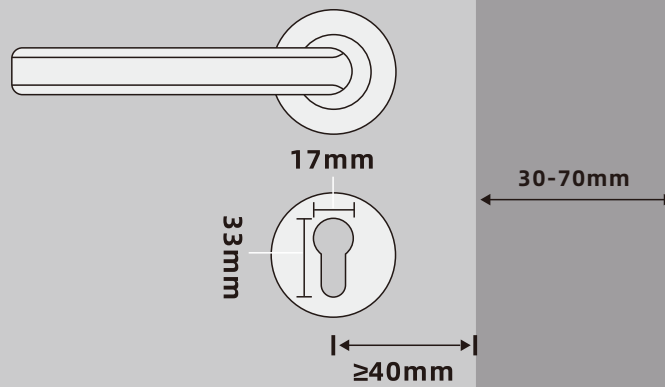

Product Components

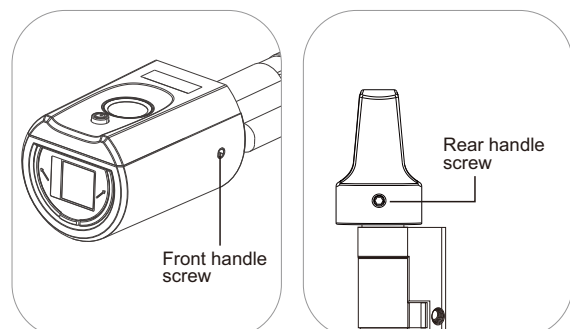
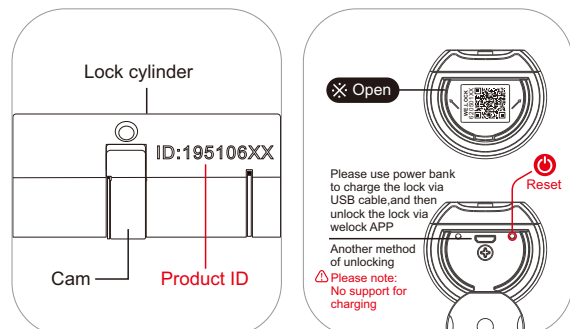
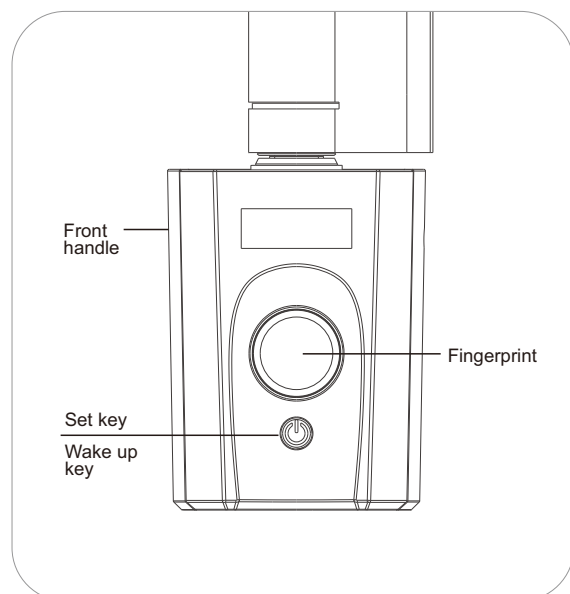

Accessories list (TOOL BOX)

If there is a lack of accessories, please contact customer service in time.

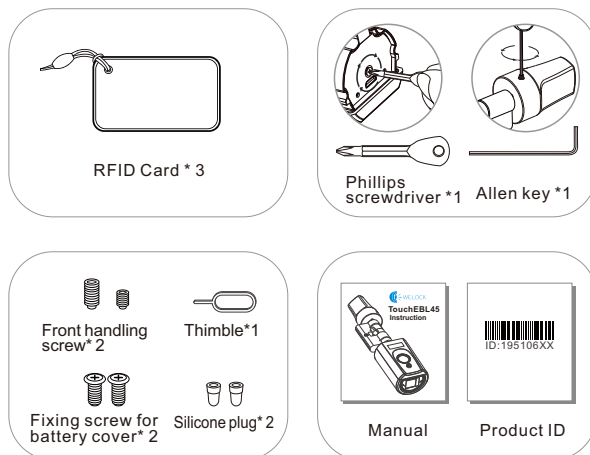

Install battery

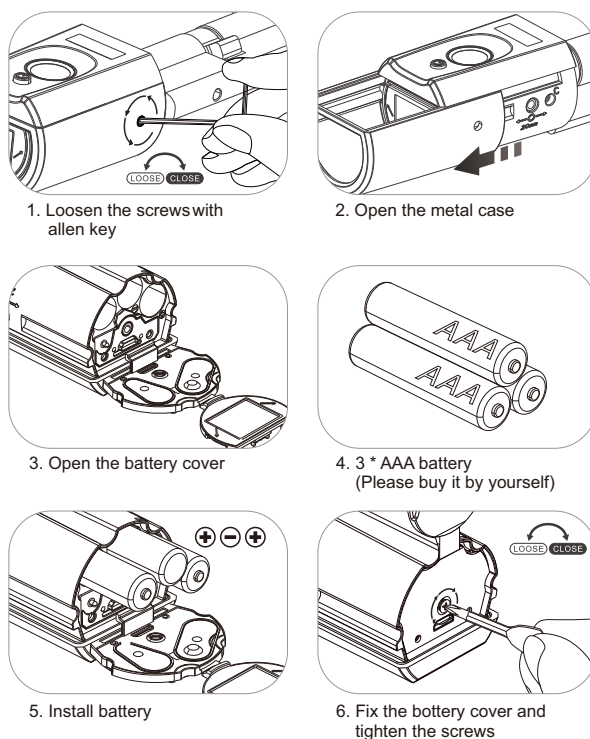

Adjust the length of the cylinder

Depending on the required cylinder length you can adjust the interior and exterior length by loosening the screw with the screwdriver and then pulling out the handle upon need. Tighten the screws after adjustment and plug the adjustment holes with silicone plug, which can play a certain waterproof effect.

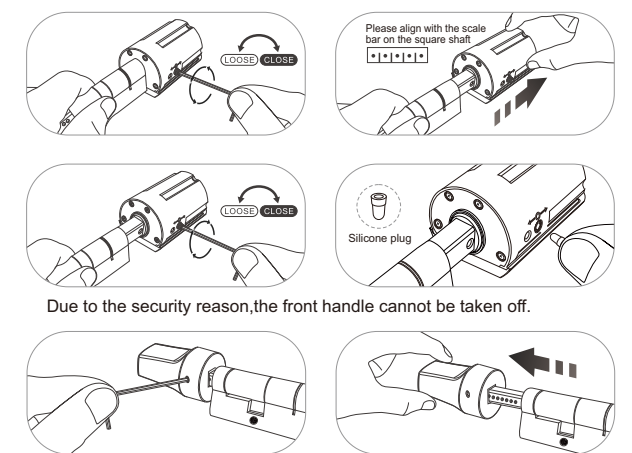

Installation pictures

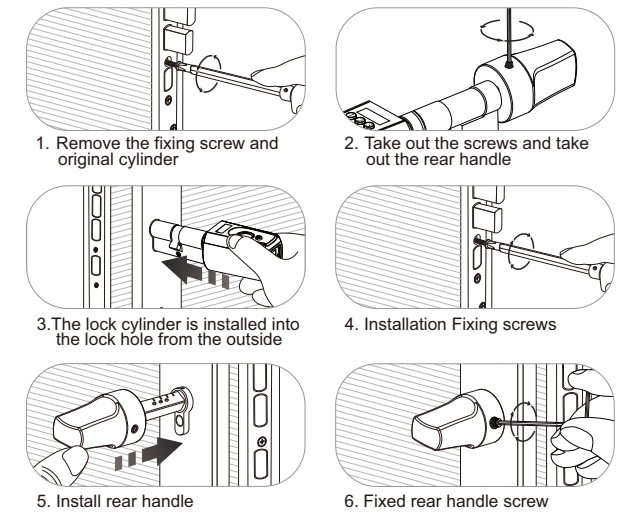

Uresetting diagram

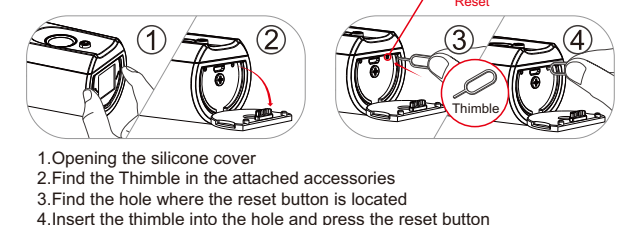

Setting operation:

Press the Set button for 5 seconds to enter the setup menu and set the fingerprint lock function. Press the set button several times to switch between different settings.

Each button needs to be completed within 2 seconds.

1. Register administrator fingerprint

Press the Set button for 5 seconds, add an admin fingerprint. A total of 3 admin fingerprints can be set. Only administrators can set up operations. When registering the first administrator, there is no need to verify the admin fingerprint. When registering the follow-up administrator fingerprint and performing other setting operations, the registered admin fingerprint must be verified first, and subsequent operations can be performed afterward. Fingerprint registration requires 3 times fingerprints scan.

2. Register user fingerprint

Press the Set button for 5 seconds, verify the admin fingerprint. Press the Set button once, add user fingerprint. First verify the admin fingerprint, after the verification can be continuously registered user fingerprints, overtime can exit. The number of user fingerprints is 97. When an admin is not registered, the user fingerprints cannot be registered.

3. Delete user fingerprint:

Press the Set button for 5 seconds, verify the admin fingerprint. Press the Set button twice, delete a single user fingerprint. First, verify the admin fingerprint. After the verification pass, select to delete the fingerprint of the specified user (Press the fingerprint or delete it in the APP) (ID No.4-100).

4. Clear admin fingerprint:

Press the Set button for 5 seconds, verify the admin fingerprint. Press the Set button 3 times, delete all admin fingerprints. First, verify the admin fingerprint, after the verification pass, the system will delete all admin fingerprints.

5. Clear user fingerprint:

Press the Set button for 5 seconds, verify the admin fingerprint. Press the Set button 4 times, delete all user fingerprints. First, verify the admin fingerprint, after the verification pass, the system will delete all user fingerprints. (ID No.4-100)

6. Add RFID card:

Press the Set button for 5 seconds, verify the admin fingerprint. Press the Set button 5 times, add the RFID card. First, verify the fingerprint administrator. After the verification pass, add the RFID card. RFID cards can be added continuously. The maximum capacity is 20pcs. Supports 13.56MHZ cards.

7. Delete RFID card:

Press the Set button for 5 seconds, verify the admin fingerprint. Press the Set button 6 times, delete the RFID card. First, verify the admin fingerprint. After the verification pass, select to delete a registered RFID card. (Swipe the card or delete in the APP) (ID No.1-20)

8. Clear RFID card:

Press the Set button for 5 seconds, verify the admin fingerprint. Press the Set button 7 times, clear the RFID card. First, verify the admin fingerprint. After the verification pass, clear all registered RFID cards.

9. Add Bluetooth remoter

Press the Set button for 5 seconds, verify the admin fingerprint. Press the Set button 8 times, wait for the remote control to connect (long-press the Bluetooth remote control, release when the red indicator turns to a light-color indicator)

10. Clear Bluetooth remoter:

Press the Set button for 5 seconds, verify the admin fingerprint. Press the Set button 9 times, verify the admin fingerprint. After the verification pass, clear all Bluetooth remotes.

11. Switch language:

① After reinstalling the battery, quickly press the Set button to select the language (English, German, Chinese).
② Press the Set button for 5 seconds, verify the admin fingerprint. Press the Set button 10 times, switch language. You can switch (press the Set button) between English, German and Chinese. Language settings are not affected by the Factory Reset operation. If no registered admin, no need to verify the admin.

12. Set the lock time:

Press the Set button for 5 seconds, verify the admin fingerprint. Press the Set button 11 times, enter the lock time setting, can set the time between after unlocking to lock. The scope is 5 to 14 seconds to meet different requirements. After verifying the admin fingerprint, if press the Set button once, it means the locking time will be added 1 second, and it will display on the screen. If there is no operation in 2 seconds, the system will choose the default as the locking time. The factory setting is 10 seconds. Before registering the admin, no need to verify the admin.

13. Turn on/off Bluetooth:

Press the Set button for 5 seconds, verify the admin fingerprint. Press the Set button 12 times, turn on/off Bluetooth. If the Bluetooth is turned on status, the Bluetooth will be turned off. If the Bluetooth is turned off status, the Bluetooth will be turned on. Turn on/off Bluetooth settings are not affected by the Factory Reset operation.

14. Turn on/off sound:

Press the Set button for 5 seconds, verify the admin fingerprint. Press the Set button 13 times, turn on/off the sound. If the sound is turned on status, the sound will be turned off. If the sound is turned off status, the sound will be turned on.

15. Restore factory setting:

Press the Set button for 5 seconds, verify the admin fingerprint. Press the Set button 14 times, Clear and restore factory setting. First, verify the admin fingerprint, after passed it will delete all data including admin fingerprint, user fingerprint, and registered RFID card. If no registered admin, no need to verify the admin.

16. Lower voltage alarming:

When the voltage is lower than 3.6V, after waking up, the voltage will alarm; When the lower voltage is alarmed, please change the batter as soon as possible.

17. USB Emergency backup key

Open the QR code cover on the front handle, use the USB port to power on, and connect the App to unlock automatically.

The operation of opening the lock:

Wake up: the system will be in a dormant state usually. If need verifies the fingerprint or swipe card, first, need to press the wake-up button in a short time to wake up the system. Then, verify the fingerprint or swipe card. Press the wake-up button in 5 seconds to enter the setting menu. Before registering any fingerprint, any fingerprint and RFID card can open the lock. After registered fingerprint and RFID card, need registered fingerprint or RFID card to unlock. After verifying the fingerprint and RFID card successfully, the display screen will display the user ID No. The unlock time is 5 to 14 seconds, then the lock will lock automatically.

Unlock and lock

Unlock the door from outside

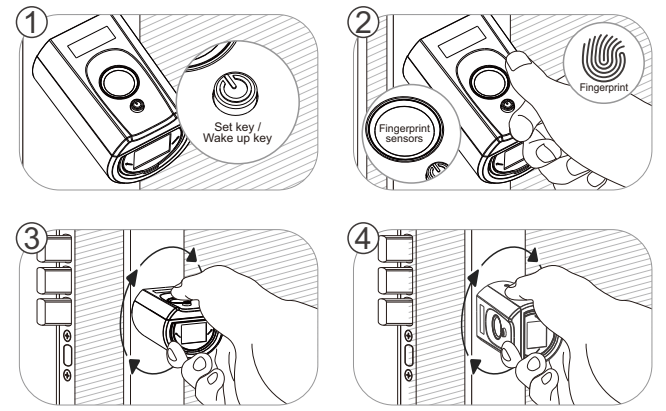

The knob can be rotated 360 degree freely after locked. To protect the lock not be damaged by torsion forcefully.

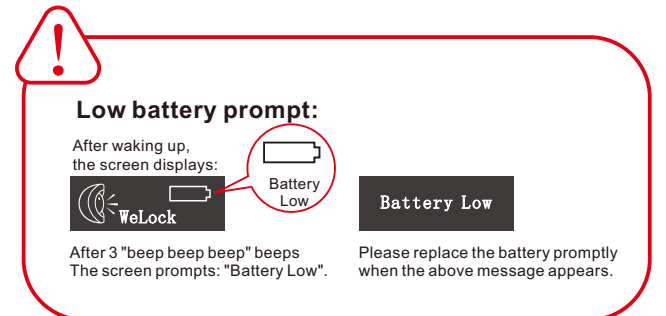

Bluetooth activation and login instructions

Scan the QR code on the lock



Select "Android/iOS" to download

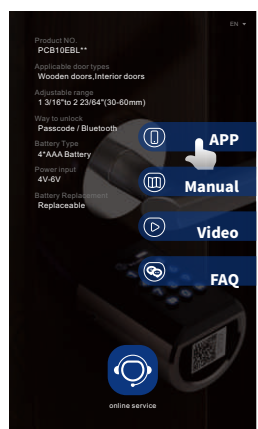

Log in to the app

- Select your country/region
- Enter the phone number/email to get the verification code
- Click "Send"
- Enter the verification code after receiving the message
- Click "Login"

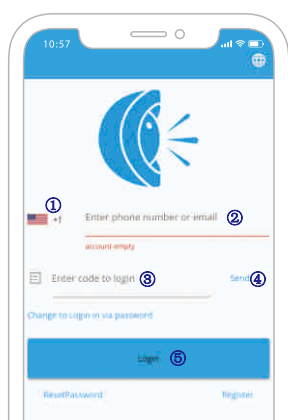

Bind the device

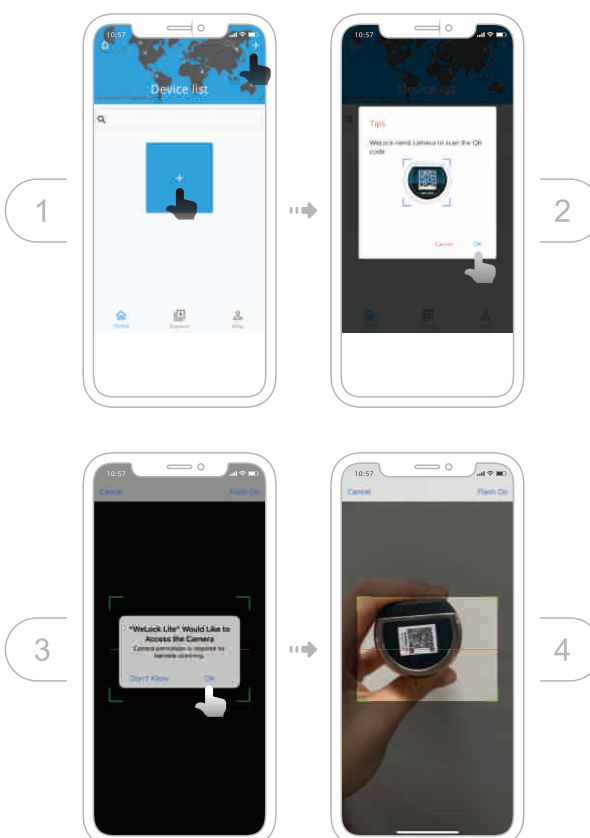

Specifications

Brand	WE.LOCK
Applicable door types	Wooden doors, Interior doors
Adjustable range	50-100 mm
Operating Temperature	-25°C - 60°C
Pressing Cycle Times	100,000 Times
Material of handle	Zinc Alloy
Way to unlock	Fingerprint / RFID card / Bluetooth
Battery Type	3*AAA Battery
Power input	3.6V-4.5V
Battery Replacement	Replaceable
Color	Silver
Battery Life	10-12 months

FAQ

- How can I know the lock is out of power?**
Each time you use, there is a screen above the fingerprint device shows the power. Low battery suitable, APP will prompt lowbattery tips, and send text messages to the phone.
- Does the lock knob still works after I replaced the lock?**
It still works. It only replace the cylinder. It won't effect the other function of the original lock.
- Will it read slowly or fail to recognize the fingerprint after long time using?**
It won't. The fingerprint sensor has a special protect film on it.
- Is it complicated to set?**
It's easy. You just need to use the thimble to press the set key to register the fingerprint. The screen will show you the function to choose and just press your fingerprint on it.
- If we install all the houses' doors with We.Lock, can we use the phone APP to unlock all of it?**
Yes, you can. One phone can in charge many different locks. Just remember to mark the name of each lock.
- Online Service:**
Email : service@welockglobal.com