

## Installation Instructions For Part # 9824F

Step One: Start by removing all of the factory plastic skid plates.

Step Two: Start by installing your 782M plate first. Set the plate into position and hang the appropriate clamps around the frame. There are two sizes of clamps for this plate. Start the bolts into the clamps, but leave everything loose for now. The two tabs that come up on the side of the plate will fit behind the factory body work. Start these bolts to secure the bodywork to the plate, but leave these loose for now. Next you can mount the front bracket using the 6x16 Flange bolt. Leave this loose for now.

Step Two: to mount the very front plate, set it into position and start the two 8x25 Torx bolts into the bracket. This mount is a common mount with the 782M plate. Now you can start the very front bolts. Again leaving everything loose.

Step Three: Now you can mount your 524 rear plate. The front mounts will pick up factory holes. Set the plate into position and run the bolts through the skid plate and the factory holes. Followed with the two washers and nylock nuts. Leave these loose for now. Next you can start the rear mounting bolts into the threaded holes. At this point you can square up all of your plates for the best fit, and you can fully tighten all of the hardware.

Step Four: To mount the front a arm skids, you first have to get the front wheels off of the ground, so the suspension is at full droop. Now you can set the a arm skid into position and start the bolts into the clamps. Leave them all loose for now. Now you need to turn the handle bars to full lock in one direction, and verify you have clearance around the a arm skid. Next turn the handle bars full lock in the other direction, and confirm you have clearance around the a arm skid. If you do you can fully tighten down the bolts. If you do not have clearance, adjust the a arm skid until you do have clearance. It is the same procedure for both sides of the machine.

## Mounting Instructions P/N 976FB Floorboard Plates

1. Remove the 2 bolts holding down the serrated footrest.
2. Referring to the diagrams below install and orient the mount as shown. Be sure the spacer tubes slips over the welded on nuts.
3. Replace the footrest using the 6mm washers and nylock nuts. You may need to put an allen wrench on the M6 X 80 flathead bolts because when the locking part of the nut hits the top of the bolt it may want to back off.
4. Install the skidplate first using the M6 X 16 flanged bolts and the cupped washers. Leave these several turns loose for now.
5. Install the 7/8" clamps over the front of the plate and around the frame tube. Now push the plate up and against the frame and completely tighten these. Due to the all metal locknut welded to those clamps a little lubrication is a good thing, grease or anti-seize compound is best.
6. Now fully tighten the M6 bolts.

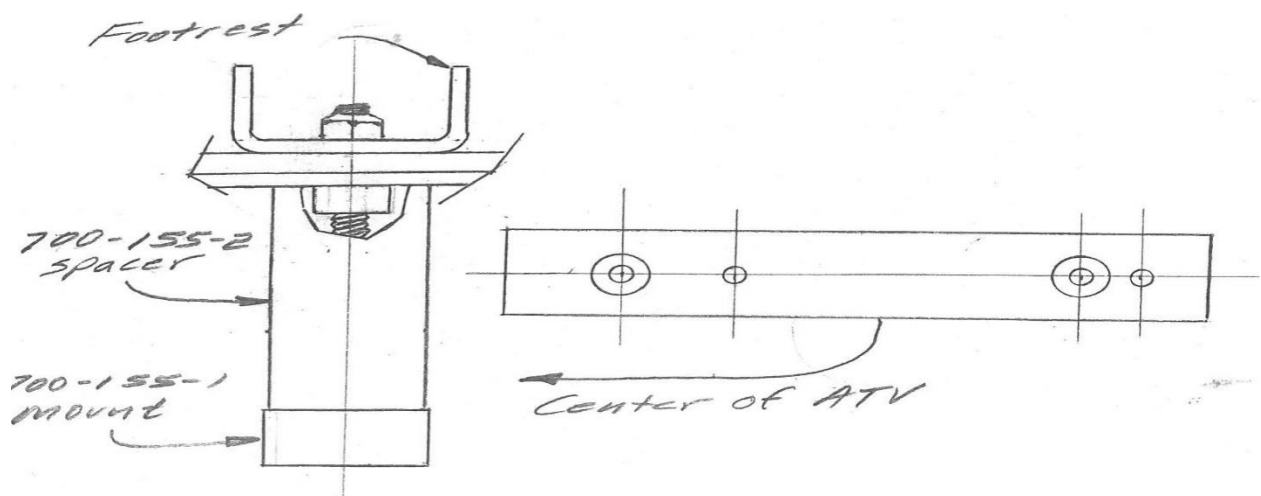

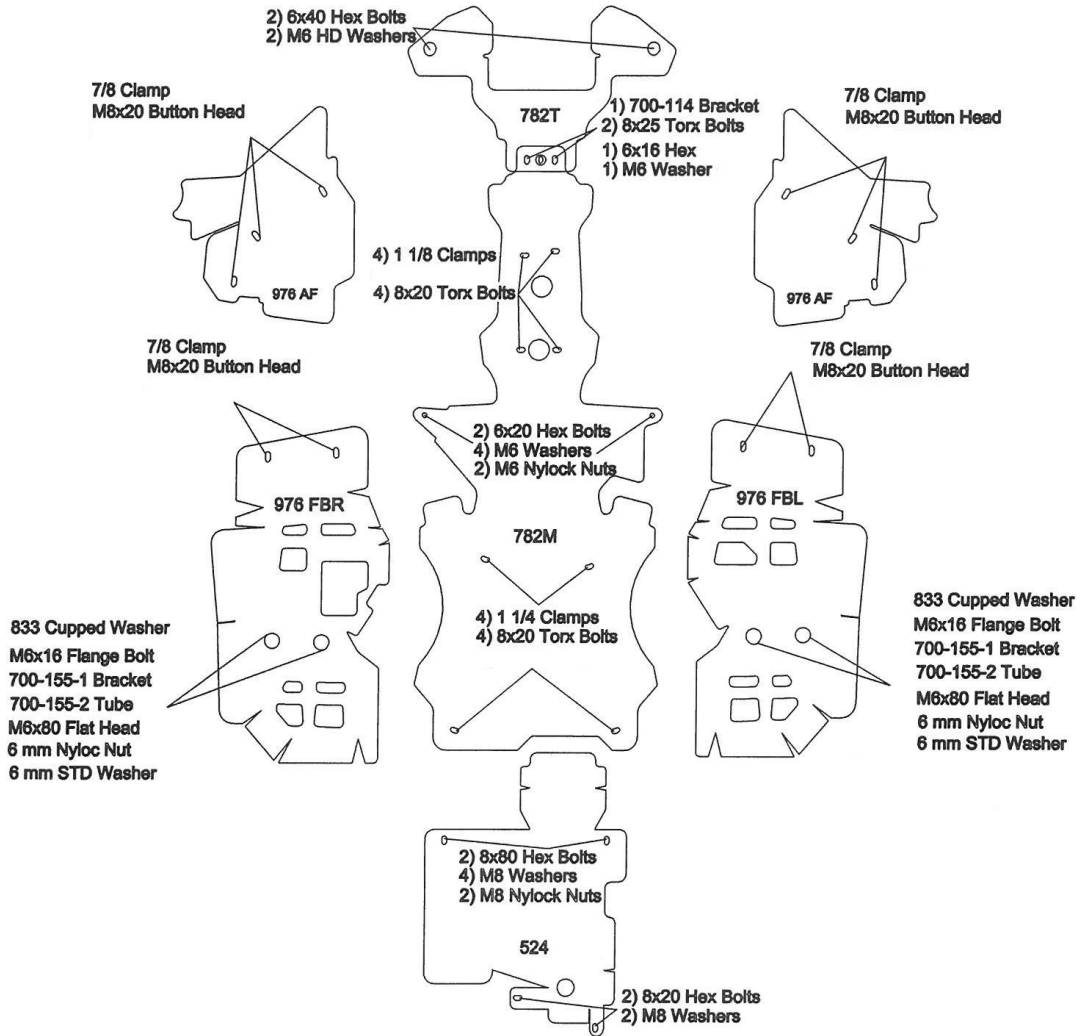

## Hardware List For Part# 9824F

### 782T

- 2) 6x40 Hex Bolts
- 2) M6 HD Washers
- 1) 700-114 Bracket
- 2) 8x25 Torx Bolts
- 1) 6x16 Hex
- 1) M6 Washer

### 976AF

- 6) 7/8 Clamps
- 6) 8x20 Torx

### 524

- 2) 8x80 Hex Bolts
- 2) 8x20 Hex Bolts
- 6) M8 Washers
- 2) M8 Nylock Nuts

### 782M

- 4) 1 1/8 Clamps
- 4) 1 1/4 Clamps
- 8) 8x20 Torx
- 2) 6x20 Hex Bolts
- 4) M6 Washers
- 4) M6 Nylock Nuts

### 976FB

- 4) 7/8 Clamps
- 4) 8x20 Torx Bolts
- 4) 833 Cup Washers
- 4) 6x16 Flange Bolts
- 2) 700-155-1 Bracket
- 4) 700-155-2 Tube
- 4) 6x80 Flat Head
- 4) M6 Nylock Nuts
- 4) M6 Washers