



UTV & ATV Armor Kit Installation Tips

Thank for your purchase of this Ricochet Off-Road Armor Kit. All of our kits are custom designed to fit each model and should install hassle free with no additional modifications required. Please carefully read through all included instruction sheets before beginning your install.

The tips described on this sheet are general mounting tips that may or may not apply to your particular model, refer to the attached model specific instructions for a step by step mounting procedure.

If you do encounter a problem during installation please check the FAQ on our website or feel free to contact us by phone or email using the contact info at the bottom of this page.

Required Tools:

(refer to your hardware placement guide for bolt sizes)

Button Head TORX Bolts: (socket bit is highly recommended)

8mm bolts use a T-40 TORX bit

6mm bolts use a T-30 Torx bit

Hex Bolts & Nuts:

10mm bolts uses 17mm

8mm bolts uses 13mm

6mm bolts uses 10mm

1/4"-20 bolts uses 7/16"

Drill Bits:

While we try to avoid drilling whenever possible some models require one or two mounting points to be match drilled. When instructions call for a drilled mounting point use an **11/32"** bit to match drill through the mounting point on the skid plate only after the plate has been fully secured to your machine using the other hardware listed on your hardware guide.

Locking Nuts:

Most sets will include two types of locking nuts. Loose nuts are Nylock, and any nuts welded onto other hardware are pinch-style Stover lock nuts. It is highly recommended that you use a bit of Anti-seize or a drop of oil on the threads of the welded-on pinch style nuts, this will make the bolts go on and come off much easier.

Other helpful tips:

- Before you begin the installation organize all the included hardware according to the hardware placement sheet so you can quickly find the correct bolts and brackets when you need them.
- Install all bolts finger-tight at first until all hardware has been installed, this will give you maximum adjustability.
- When using the cupped washers to secure the plates to factory mounting points do not over torque the bolts because the threads can strip easily. If you do strip one out the simplest way to repair the thread is to use a 1/4"-20 x 5/8" self tapping bolt.
- You may find it easier to remove the rear tires when installing the rear a-arm guards, it's typically very tight and hard to see when the tires are left on.

Contact us at 1-866-273-1197 or dh_gibbs@comcast.net with any questions or concerns.

Clamp & Hardware Placement for P/N 9116F

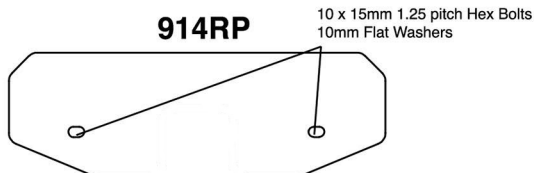
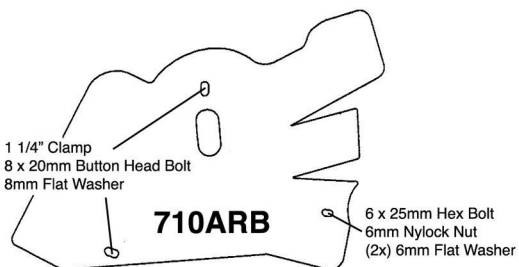
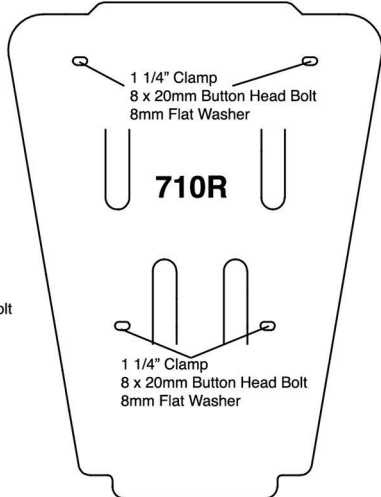
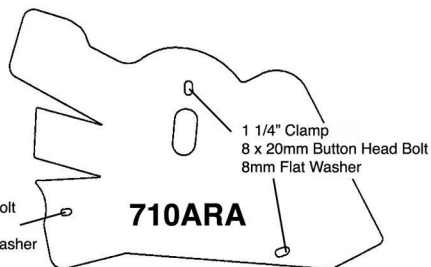
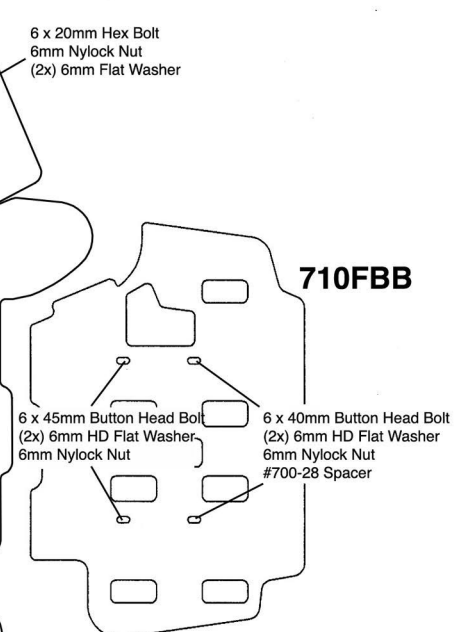
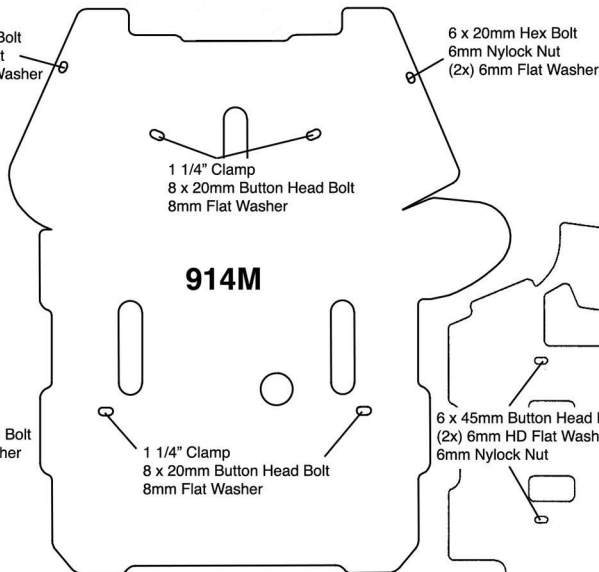
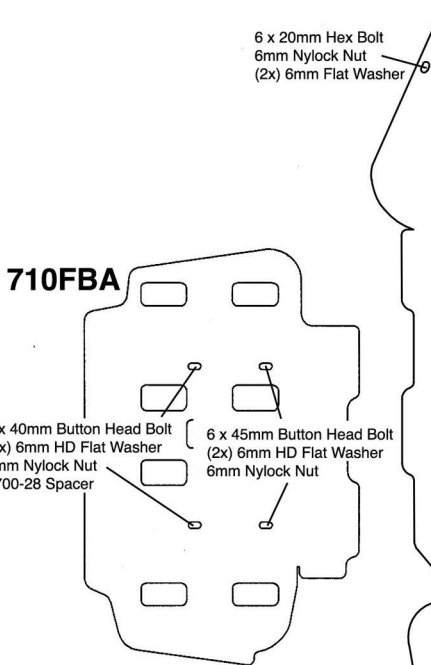
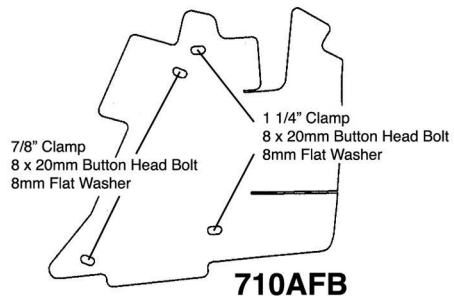
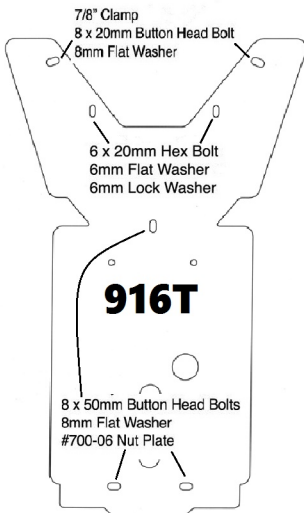
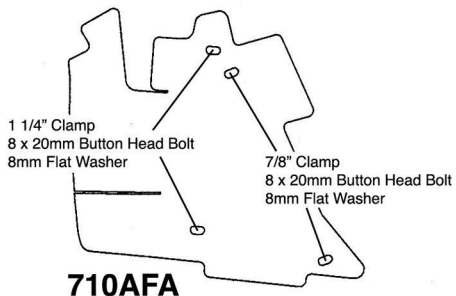

Hardware List & Mounting Instructions for P/N 9116F

Front Bash Plate: (P/N 916T)

- 2) 7/8" Clamps
- 3) #700-06 Nut Plates
- 2) 8 x 20mm Button Head bolts
- 3) 8 x 50mm Button Head Bolts
- 5) 8mm Flat Washers
- 2) 6 x 20mm Hex Bolts
- 4) 6mm Flat Washers
- 2) 6mm Nylock Nuts

Center Skid Plate (P/N 914M)

- 2) 6 x 20mm Hex Bolts
- 4) 6mm Flat Washers
- 2) 6mm Nylock Nuts
- 4) 8 x 20mm Button Head Bolts
- 4) 8mm Flat Washers
- 4) 1 1/4" Clamps

Rear Skid Plate (P/N 710R)

- 4) 1 1/4" Clamps
- 4) 8 x 20mm Buttonhead Bolts
- 4) 8mm Flat Washers

Front A-Arm Guards: (P/N 710AFA, 710AFB)

- 4) 1 1/4" Clamps
- 4) 7/8" Clamps
- 8) 8 x 20mm Button Head Bolts
- 8) 8mm Flat Washers

Rear A-Arm Guards: (P/N 710ARA, 710ARB)

- 4) 1 1/4" Clamps
- 4) 8 x 20mm Button Head Bolts
- 4) 8mm Flat Washers
- 2) 6 x 25mm Hex Bolts
- 4) 6mm HD Flat Washers
- 2) 6mm Nylock Nuts

REAR HITCH

914-FH-RP

2) 1 INCH CLAMPS WITH BOLT AND WAHERS

914-FH

- 2) 10X16X1.25 HEX
- 2) 10MM WASHER

710FB

- 4) 6X40 TORX
- 4) 6X45 TORX
- 8) M6 NYLOCK
- 16) 6MM HD WAHERS
- 4) 700-28 SPACERS

PLASTIC/UHMW OVERLAY (914P1/914P2/914P3L/P3R

914P1

15) 833 CUP WAHSER

12) M6X16 FLAGE

3) M6X20 HEX

914P2

8) 833 CUP WASHER

8) M6X16 FLANGE

914P3L/P3R

10) 833 CUP WASHER

10) M6X16 FLANGE

1. Begin by standing the ATV up on its end. They are very unstable in this position so be sure to secure it with rope.
2. Remove all factory plastic skid plates and a-arm guards.
3. It is recommended to use a little oil or anti-seize compound on the threads of each bolt used with a clamp.
4. Now install the center plate beneath the engine. Mount to the frame using four of the 1 1/4" clamps with 8 x 20mm Button Head Bolts and secure on each side to the plastic splash guard using the supplied 6 x 20mm Hex Bolts with Nylock Nuts. Its best to install all of the hardware loosely at first so that the position of the plate can still be adjusted.
5. Next install the front bash plate using the 6 x 30mm Hex Bolts with standard and lock washers into the front factory mounting holes. Secure this plate to the frame using the 8 x 50mm Button Head Bolt and the #700-06 Nut Plate in the other three mounting points. Again install everything loosely so that the plate can be butted up against the center plate before tightening.
6. Now install the rear skid plate using four 1 1/4" clamps with 8 x 20mm Button Head Bolts.
7. Finally install the A-Arm Guards using the hardware shown on your hardware placement guide. After you have installed the front A-Arm guards turn the tires full lock in both directions checking for any interferences with the CV boot or brake. If there is an interference loosen the clamps and adjust the guards position accordingly.
8. To install the rear hitch guard bring the ATV down on all 4 tires and install the guard on the vertical posts just behind the hitch. Position the guard to give the rear inner boots the best protection possible.