



UTV & ATV Armor Kit Installation Tips

Thank for your purchase of this Ricochet Off-Road Armor Kit. All of our kits are custom designed to fit each model and should install hassle free with no additional modifications required. Please carefully read through all included instruction sheets before beginning your install.

The tips described on this sheet are general mounting tips that may or may not apply to your particular model, refer to the attached model specific instructions for a step by step mounting procedure.

If you do encounter a problem during installation please check the FAQ on our website or feel free to contact us by phone or email using the contact info at the bottom of this page.

Required Tools:

(refer to your hardware placement guide for bolt sizes)

Button Head TORX Bolts: (socket bit is highly recommended)

8mm bolts use a T-40 TORX bit

6mm bolts use a T-30 Torx bit

Hex Bolts & Nuts:

10mm bolts uses 17mm

8mm bolts uses 13mm

6mm bolts uses 10mm

1/4"-20 bolts uses 7/16"

Drill Bits:

While we try to avoid drilling whenever possible some models require one or two mounting points to be match drilled. When instructions call for a drilled mounting point use an **11/32"** bit to match drill through the mounting point on the skid plate only after the plate has been fully secured to your machine using the other hardware listed on your hardware guide.

Locking Nuts:

Most sets will include two types of locking nuts. Loose nuts are Nylock, and any nuts welded onto other hardware are pinch-style Stover lock nuts. It is highly recommended that you use a bit of Anti-seize or a drop of oil on the threads of the welded-on pinch style nuts, this will make the bolts go on and come off much easier.

Other helpful tips:

- Before you begin the installation organize all the included hardware according to the hardware placement sheet so you can quickly find the correct bolts and brackets when you need them.
- Install all bolts finger-tight at first until all hardware has been installed, this will give you maximum adjustability.
- When using the cupped washers to secure the plates to factory mounting points do not over torque the bolts because the threads can strip easily. If you do strip one out the simplest way to repair the thread is to use a 1/4"-20 x 5/8" self tapping bolt.
- You may find it easier to remove the rear tires when installing the rear a-arm guards, it's typically very tight and hard to see when the tires are left on.

Contact us at 1-866-273-1197 or dh_gibbs@comcast.net with any questions or concerns.

Hardware List for P/N 7553

Bash Plate (P/N 753T)

- 6) 8 x 30mm Button Head Bolts
- 6) 8mm Flat Washers
- 2) #700-02 Nut Plates
- 2) #700-06 Nut Plates

700-06



Center Skid Plate (P/N 753M)

- 11) 1/4 x 20 Hex Bolts
- 11) 1/4" Lock Washers
- 11) #832 Cupped Washer

700-02



Rear Skid Plate (P/N 753R)

- 2) 8 x 50mm Button Head Bolts
- 1) 8 x 20mm Button Head Bolt
- 3) 8mm Flat Washers
- 3) #700-06 Nut Plates
- 1) 1/4 x 20 Hex Bolts
- 1) 1/4" Lock Washers
- 1) #832 Cupped Washer

Front A-Arm Guards (P/N 753AFA & 753AFB)

- 6) 1" Clamps
- 6) 8 x 20mm Button Head Bolts
- 6) 8mm Flat Washers

Rear A-Arm Guards (P/N 753ARA & 753ARB)

- 8) #826 Clamps
- 8) 8 x 20mm Button Head Bolts
- 8) 8mm Flat washers

Mouting Tips

- Begin by removing all factory plastic skid plates.
- Apply a drop of oil or anti-sieze compound to the threads off each of the locking nuts welded on to the clamps and nut plates.
- The two rear mounting points on the front bash plate will need to be drilled using a 3/8" bit. Install the front bash plate using the 8 x 30s with the #700-02 nut plate and match drill through the rear mounting holes on the skid plate through the frame, then attach the plate using the 8 x 30s with the #700-06 nut plates behind the frame.
- Now install the rest of your skid plates using the hardware listed on your hardware placement guide, leave everything loose at first until all the bolts are threaded into place. Then you may tighten everything down keeping the plates butted up against one another to create smooth transitions between the plates

Clamp & Hardware Placement Guide for P/N 7553

753AFA

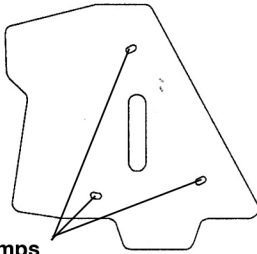

1" Clamps
8 x 20mm Button Head Bolt
8mm Flat Washer

753T

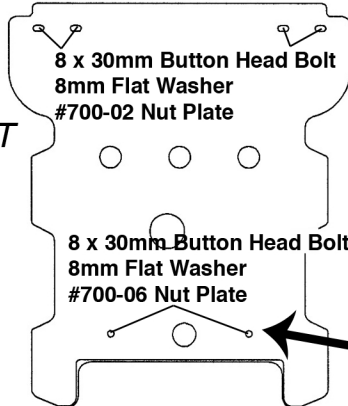

8 x 30mm Button Head Bolt
8mm Flat Washer
#700-02 Nut Plate

8 x 30mm Button Head Bolt
8mm Flat Washer
#700-06 Nut Plate

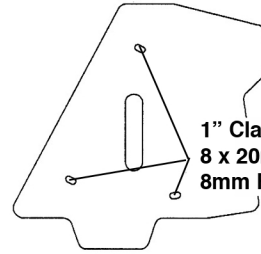

753AFB

1" Clamps
8 x 20mm Button Head Bolt
8mm Flat Washer

Note: These Mounting Holes need to be drilled in the frame using a 3/8" bit. Install this plate first.

753M

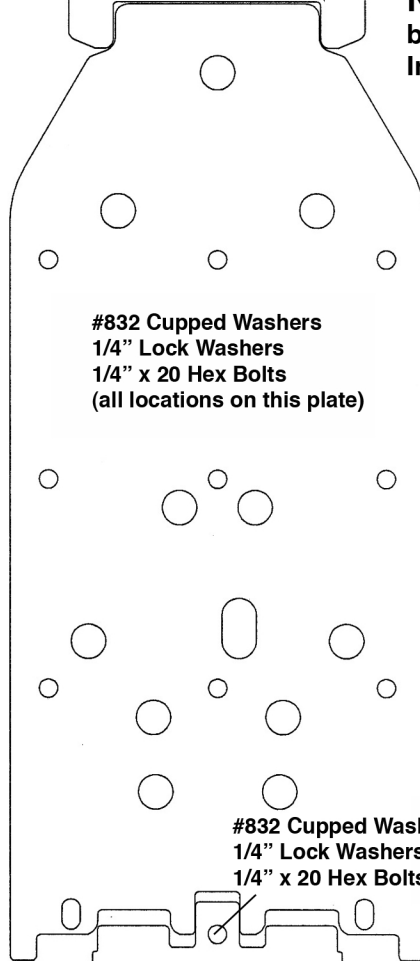

#832 Cupped Washers
1/4" Lock Washers
1/4" x 20 Hex Bolts
(all locations on this plate)

#832 Cupped Washers
1/4" Lock Washers
1/4" x 20 Hex Bolts

753R

8 x 50mm Button Head Bolt
8mm Flat Washer
#700-06 Nut Plate

753ARA

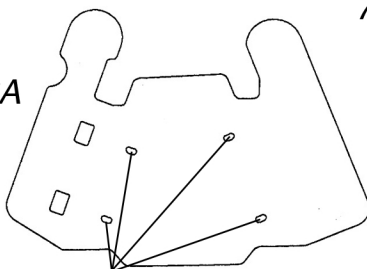

#826 Clamp
8 x 20mm Button Head Bolt
8mm Flat Washer

753ARB

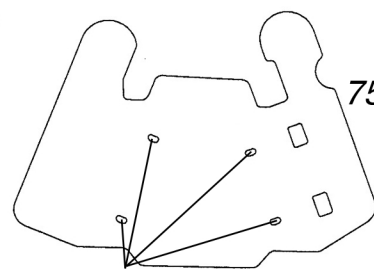

#826 Clamp
8 x 20mm Button Head Bolt
8mm Flat Washer

8 x 20mm Button Head Bolt
8mm Flat Washer
#700-06 Nut Plate