

SPIRIT



XT185 Treadmill
OWNER'S MANUAL

TABLE OF CONTENTS

4	IMPORTANT SAFETY INSTRUCTIONS
5	IMPORTANT ELECTRICAL INSTRUCTIONS
6	IMPORTANT GROUNDING INSTRUCTIONS
7	IMPORTANT OPERATION INSTRUCTIONS
8	PRODUCT REGISTRATION
9	XT185 ASSEMBLY INSTRUCTIONS
16	CONSOLE OPERATION
22	PROGRAMMABLE FEATURES
26	GENERAL MAINTENANCE
32	MANUFACTURER'S LIMITED WARRANTY

Thank you for purchasing our product, please save these instructions. Please do not perform or attempt any customizing, adjustments, repair or maintenance that is not described in this manual.

SPIRIT

Congratulations on your new treadmill and welcome to the Spirit Fitness family!

Thank you for your purchase of this quality treadmill from Spirit Fitness. Your new treadmill was manufactured by one of the leading fitness manufacturers in the world and is backed by one of the most comprehensive warranties available. Through your dealer, Spirit Fitness will do all we can to make your ownership experience as pleasant as possible for many years to come. If not purchased direct from Spirit Fitness, the local dealership where you purchased this treadmill is your administrator for all Spirit Fitness warranty and service needs. Their responsibility is to provide you with the technical knowledge and service personnel to make your experience more informed and any difficulties easier to remedy.

Please take a moment at this time to record the name of the dealer, their telephone number, and the date of purchase below to make any future, needed contact easy. We appreciate your support and we will always remember that you are the reason that we are in business.

Yours in Health,
Spirit Fitness

NAME OF DEALER _____

DEALER PHONE # _____

PURCHASE DATE _____

Important Safety Instructions

WARNING

When using an electrical appliance, basic precautions should always be followed, including the following:

Read all instructions before using this appliance.

DANGER - To reduce the risk of electric shock:

Always unplug this appliance from the electrical outlet immediately after using and before cleaning.

WARNING - To reduce the risk of burns, fire, electric shock, or injury to persons, install the treadmill on a flat level surface with access to a 110-volt, 15-amp grounded outlet with only the treadmill plugged into the circuit.

DO NOT USE AN EXTENSION CORD UNLESS IT IS A 14AWG OR BETTER, WITH ONLY ONE OUTLET ON THE END:

- To reduce the risk of burns, fire electric shock, or injury to persons:
- An appliance should never be left unattended when plugged in. Unplug from outlet when not in use, and before putting on or taking off parts.
- Do not operate under blanket or pillow. Excessive heating can occur and cause fire, electric shock, or injury to persons.
- Close supervision is necessary when this appliance is used by, on, or near children, invalids, or disabled persons.
- Use this appliance only for its intended use as described in this manual. Do not use attachments not

recommended by the manufacturer.

- Never operate this appliance if it has a damaged cord or plug, if it is not working properly, if it has been dropped or damaged, or dropped into water. Return the appliance to a service center for examination and repair.
- Do not carry this appliance by supply cord or use cord as a handle.
- Keep the cord away from heated surfaces.
- Never operate the appliance with the air openings blocked. Keep the air openings free of lint, hair, and the like.
- Never drop or insert any object into any opening.
- Do not use outdoors.
- Do not operate where aerosol (spray) products are being use or where oxygen is being administered.
- Connect this appliance to a properly grounded outlet only.
- The appliance is intended for household use.
- This appliance is not intended for use by persons with reduced physical, sensory or metal capabilities, or lack of experience and knowledge, unless they have been given supervision or instruction concerning use of the appliance by a person responsible for their safety.
- Keep children under the age of 13 away from this machine.

SAVE THESE INSTRUCTIONS - THINK SAFETY!

Fitness Equipment Safety Instructions

- Do not operate equipment on deeply padded, plush or shag carpet. Damage to both carpet and equipment may result.
- Before beginning this or any exercise program, consult a physician. This is especially important for persons over the age of 35 or persons with pre-existing health conditions.
- Do not attempt to use your equipment for any purpose other than for the purpose it is intended.
- Keep hands away from all moving parts.
- The pulse sensors are not medical devices. Their purpose is to provide you with an approximate measurement in relation to your target heart rate. Use of a chest transmitter strap (sold separately) is a much more accurate method of heart rate analysis. Various factors, including the user's movement, may affect the accuracy of heart rate readings. The pulse sensors are intended only as exercise aids in determining heart rate trends in general.
- Wear proper shoes. High heels, dress shoes, sandals or bare feet are not suitable for use on your equipment. Quality athletic shoes are recommended to avoid leg fatigue.

Failure to follow all guidelines may compromise the effectiveness of the exercise experience, expose yourself (and possibly others) to injury, and reduce the longevity of the equipment.

Important Electrical Instructions

WARNING

NEVER use a ground fault circuit interrupt (GFCI) wall outlet with this treadmill. As with any appliance with a large motor, the GFCI will trip often. Route the power cord away from any moving part of the treadmill including the elevation mechanism and transport wheels.

NEVER remove any cover without first disconnecting AC power. If voltage varies by ten percent (10%) or more, the performance of your treadmill may be affected. Such conditions are not covered under your warranty. If you suspect the voltage is low, contact your local power company or a licensed electrician for proper testing.

NEVER expose this treadmill to rain or moisture. This product is NOT designed for use outdoors, near a pool or spa, or in any other high humidity environment. The operating temperature specification is 40 to 120 degrees Fahrenheit, and humidity is 95% non-condensing (no water drops forming on surfaces).

Circuit Breakers: Some circuit breakers used in homes are not rated for high inrush currents that can occur when a treadmill is first turned on or even during use. If your treadmill is tripping the house circuit breaker (even though it is the proper current rating) but the circuit breaker on the treadmill itself does not trip, you will need to replace the home breaker with a high inrush type. This is not a warranty defect. This is a condition we as a manufacture have no ability to control. This part is available through most electrical supply stores. *Examples: Grainger part # 1D237, or available online at www.squared.com part #QO120HM. The electrical outlet used should have a dedicated 15 amp circuit breaker.*

Grounding Instructions

This product must be grounded. If the your equipment should malfunction or breakdown, grounding provides a path of least resistance for electric current, reducing the risk of electric shock. This product is equipped with a cord having an equipment-grounding plug. The plug must be plugged into an appropriate outlet that is properly installed and grounded in accordance with all local codes and ordinances.

DANGER - Improper connection of the equipment-grounding conductor can result in a risk of electric shock. Check with a qualified electrician or serviceman if you are in doubt as to whether the product is properly grounded. Do not modify the plug provided with the product if it will not fit the outlet; have a proper outlet installed by a qualified electrician.

This product is for use on a nominal 110-volt/15 amp dedicated circuit, and has a grounding plug that looks like the plug illustrated below. A temporary adapter that looks like the adapter illustrated below may be used to connect this plug to a 2-pole receptacle as shown below if a properly grounded outlet is not available. The temporary adapter should be used only until a properly grounded outlet, (shown below) can be installed by a qualified electrician. The green colored rigid ear-lug, or the like, extending from the adapter; must be connected to a permanent ground such as a properly grounded outlet box cover. Whenever the adapter is used, it must be held in place by a metal screw.

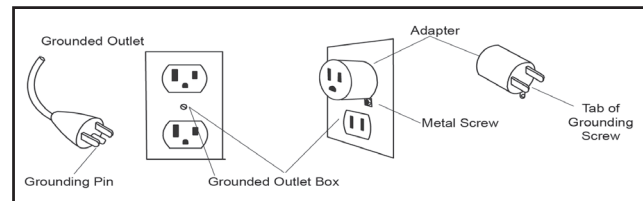

Important Operation Instructions

- **NEVER** operate this treadmill without reading and completely understanding the results of any operational change you request from the computer.
- Understand that changes in speed and incline do not occur immediately. Set your desired work level on the computer console and release the adjustment key. The computer will obey the command gradually.
- **NEVER** use your treadmill during an electrical storm. Surges may occur in your household power supply that could damage treadmill components. Unplug the treadmill during an electrical storm as a precaution.
- Use caution while participating in other activities while walking on your treadmill; such as watching television, reading, etc. These distractions may cause you to lose balance which may result in serious injury.
- Do not use excessive pressure on console control keys. They are precision set to function properly with little finger pressure

Safety Tether Cord

A safety tether cord is provided with this unit. It is a simple magnetic design that should be used at all times. It is for your safety should you fall or move too far back on the tread-belt. Pulling this safety tether cord will stop tread-belt movement.

To Use:

1. Place the magnet into position on the round metal portion of the console control head. Your treadmill will not start and operate without this. Removing the magnet also secures the treadmill from unauthorized use.
2. Fasten the plastic clip onto your clothing securely to assure good holding power. Note: The magnet has strong enough power to minimize accidental, unexpected stopping. The clip should be attached securely to make certain it does not come off. Be familiar with its function and limitations. The treadmill will stop, depending on speed, with a one to two step coast anytime the magnet is pulled off the console. Use the Stop / Pause switch in normal operation.

Record Your Serial Number

Please record the serial number of this fitness product in the space provided below.

Serial Number:

Register Your Purchase

The self-addressed product registration card must be completed in full and returned to Spirit Fitness. You can also go to <https://www.spiritfitness.com/residentialwarrantyregistration.html> under the Support tab to register online.

Serial Number Location

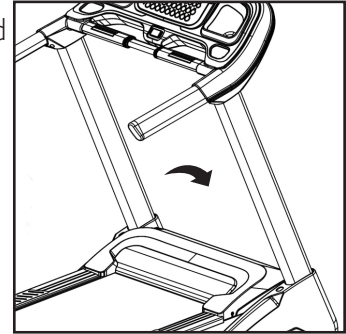

XT185 PRE ASSEMBLY

UNPACKING

1. Cut the straps, then lift the box over the unit and unpack.
2. Carefully remove all parts from the carton and inspect for any damage or missing parts. If parts are damaged or missing, contact your dealer immediately.
3. Locate the hardware package. Remove the tools first. Remove the hardware for each step as needed to avoid confusion. The numbers in the instructions that are in parenthesis (#) are the item number from the assembly drawing for reference.

TOOLS INCLUDED:

- Phillips Head Screwdriver
- M6_L Allen Wrench
- Combination M5 Allen Wrench & Phillips Head Screw Driver

PARTS INCLUDED:

- 1 Main Frame
- 2 Uprights
- 2 Frame Base Covers
- 2 Console Mast Covers
- 1 Console Assembly
- 1 Deck
- 1 Power Cord
- 1 Lubricant
- 1 Hardware Kit

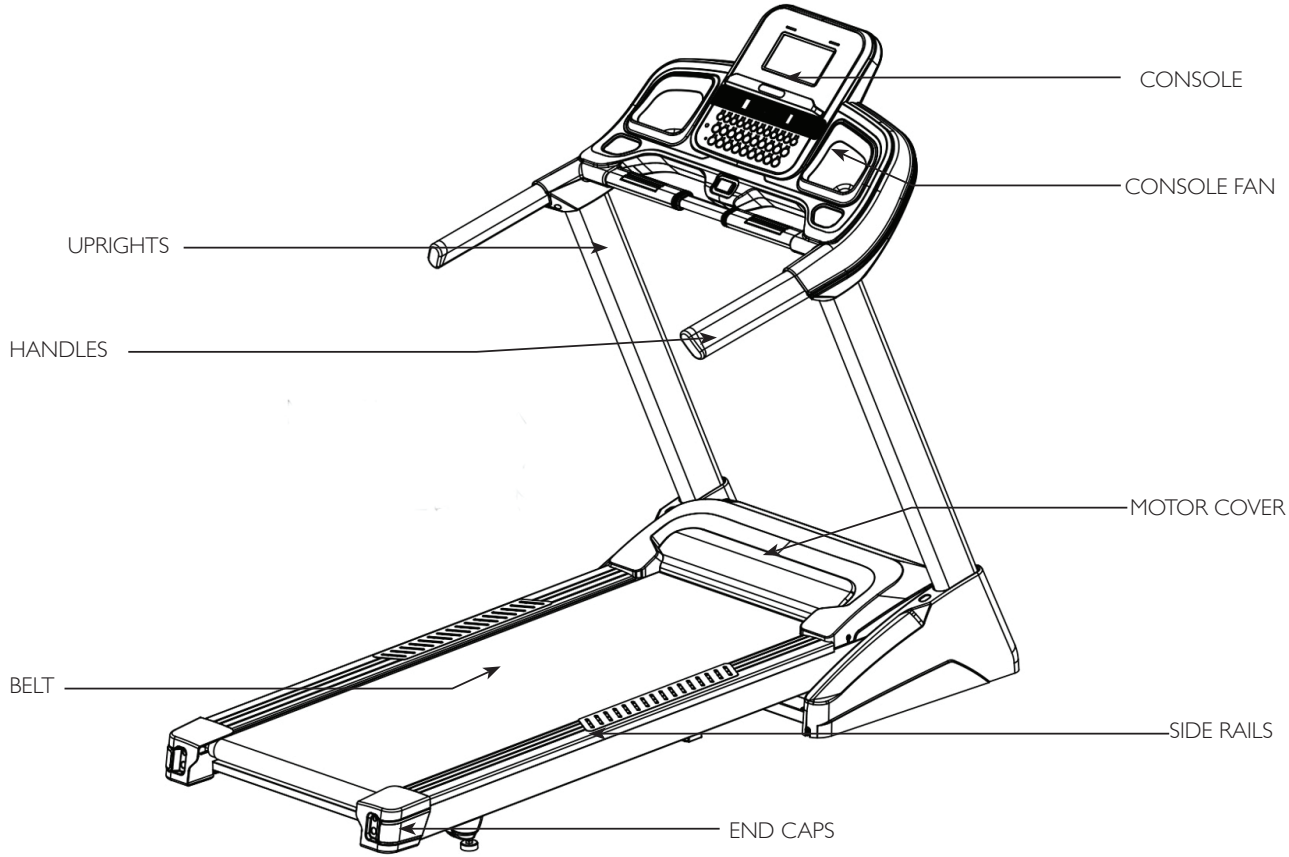

CONSOLE

CONSOLE FAN

UPRIGHTS

HANDLES

MOTOR COVER

BELT

SIDE RAILS

END CAPS

XT185 STEP ONE

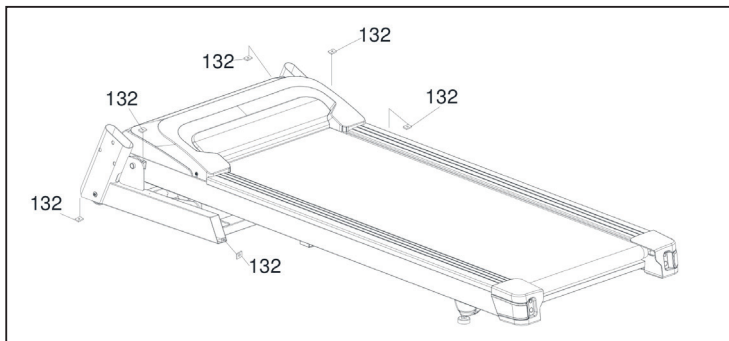

HARDWARE FOR STEP 1			
PART	TYPE	DESCRIPTION	QTY
132	NUT CLIP	M5	6

1. Gather **HARDWARE FOR STEP 1**.
2. Take 6 Speed **NUT CLIPS (132)** and attach them at the front and each side of the unit as shown left.
3. Guide the right upright through **FRAME BASE COVER RIGHT (43)** and **CONSOLE MAST COVER RIGHT (100)**.
4. Next take the **RIGHT UPRIGHT (4)** and attach the **MIDDLE COMPUTER CABLE (38)** to the **LOWER COMPUTER CABLE (39)**. Be careful not to pinch the cable or damage may occur to the system.
5. Slide the right upright (4) to sit into the frame base.
6. Repeat from step 3 on the left.

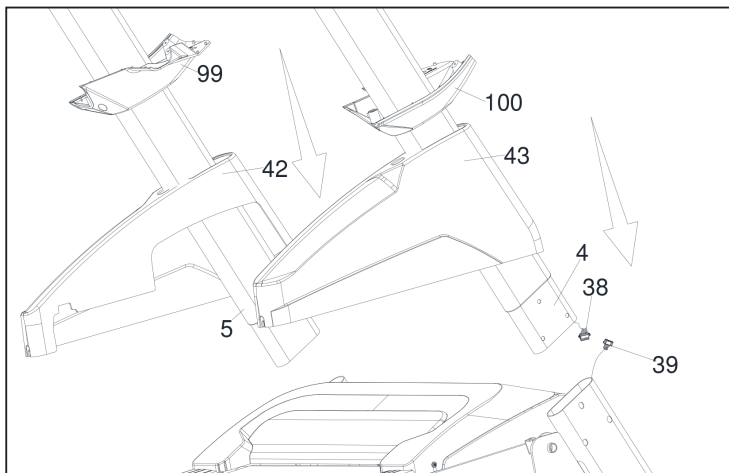

XT185 STEP TWO

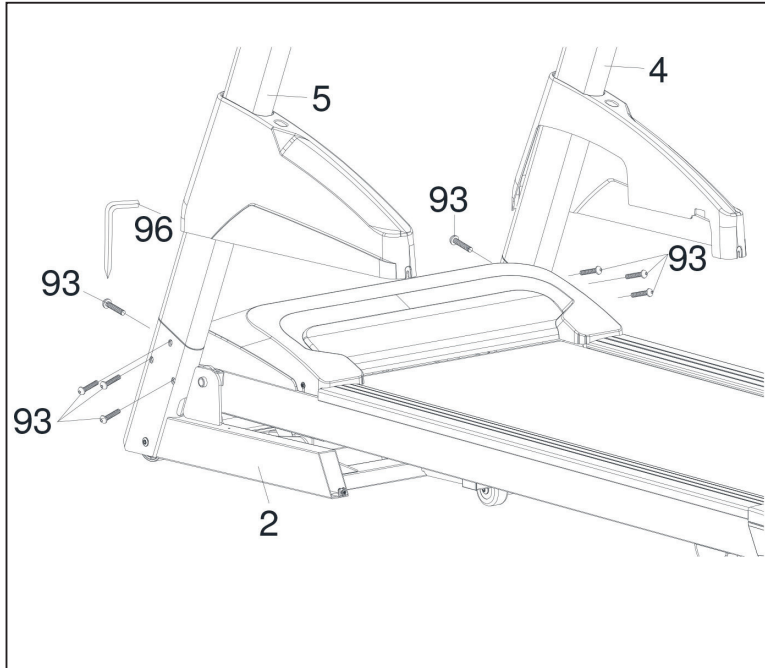

HARDWARE FOR STEP 2

PART	TYPE	DESCRIPTION	QTY
93	BOLTS	5/16" X UNC18 X 15L	8

1. Gather **HARDWARE FOR STEP 2**.
2. Having inserted **RIGHT AND LEFT UP-RIGHTS (4, 5)** into the **FRAME BASE (2)**, use the **COMBINATION M5 ALLEN WRENCH AND PHILLIPS HEAD SCREW DRIVER (96)** to tighten 8 **BUTTON HEAD SOCKET BOLTS (93)** securing the uprights to the frame base.

XT185 STEP THREE

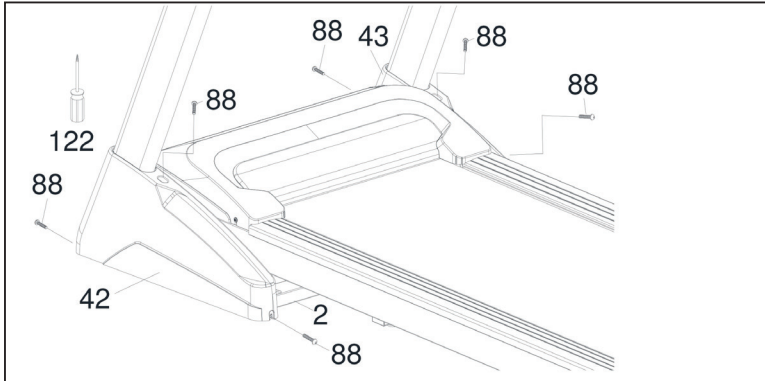

HARDWARE FOR STEP 4			
PART	TYPE	DESCRIPTION	QTY
88	TAPPING SCREWS	5"X 16MM	6

1. Gather **HARDWARE FOR STEP 4**.
2. Install **FRAME BASE COVER RIGHT AND LEFT (42, 33)** onto the **FRAME BASE (2)** using 6 **Tapping Screws (88)**. Tighten with the **PHILIPS HEAD SCREW DRIVER (122)**.

XT185 STEP FOUR

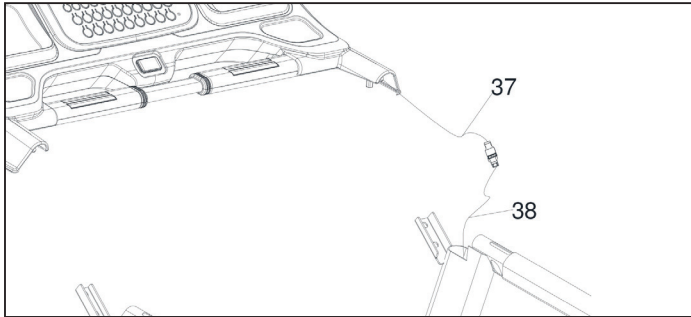

HARDWARE FOR STEP 4			
PART	TYPE	DESCRIPTION	QTY
90	BOLTS	3/8" X 1-3/4"	4
82	SPLIT WASHER	Ø10 x 2.0T	4

1. Gather **HARDWARE FOR STEP 4**
2. Connect the **MIDDLE COMPUTER CABLE (38)** to the **UPPER COMPUTER CABLE (37)**. Be careful not to pinch the cables.
3. Insert the **CONSOLE ASSEMBLY (40)** onto the **RIGHT AND LEFT UPRIGHTS (4, 5)** and secure with 4 **BUTTON HEAD SOCKET BOLTS (90)** and 4 **SPLIT WASHERS (82)**. Use the **ALLEN WRENCH (97)** to tighten.

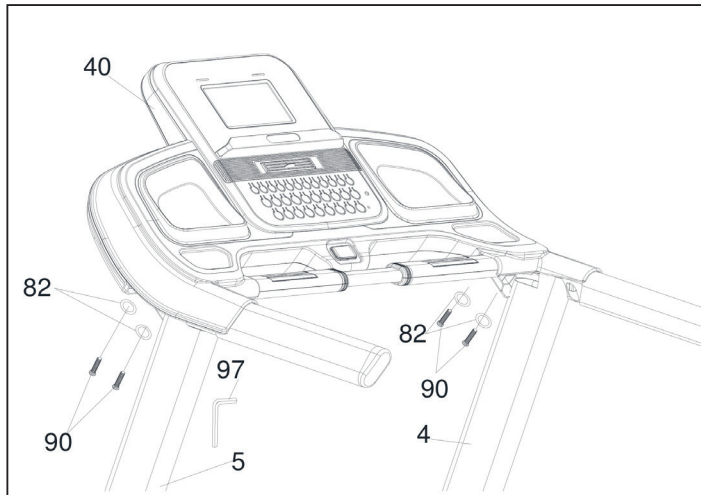

XT185 STEP FIVE

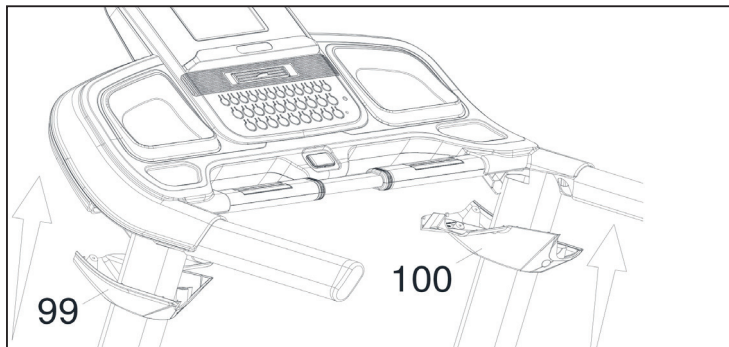

HARDWARE FOR STEP 5			
PART	TYPE	DESCRIPTION	QTY
142	SHEET METAL SCREWS	Ø3.5 × 16L	6

1. Gather **HARDWARE FOR STEP 5**.
2. Slide **CONSOLE MAST COVER RIGHT AND LEFT (100, 99)** up the uprights. Secure them with 6 **SHEET METAL SCREWS (142)** using the **PHILLIPS HEAD SCREW DRIVER (122)**.

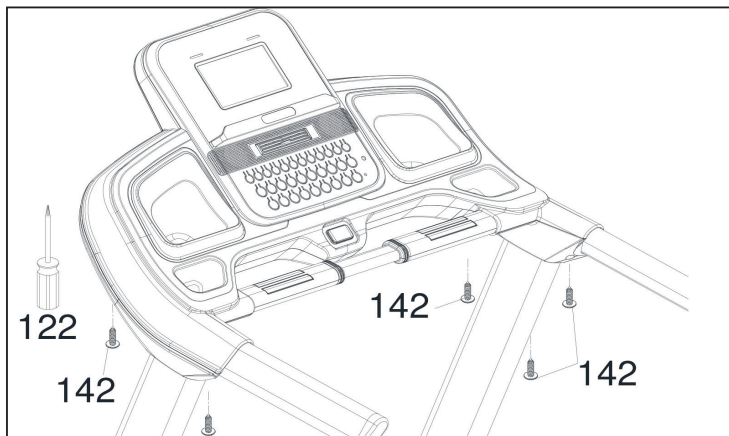

XT185 CONSOLE OPERATION

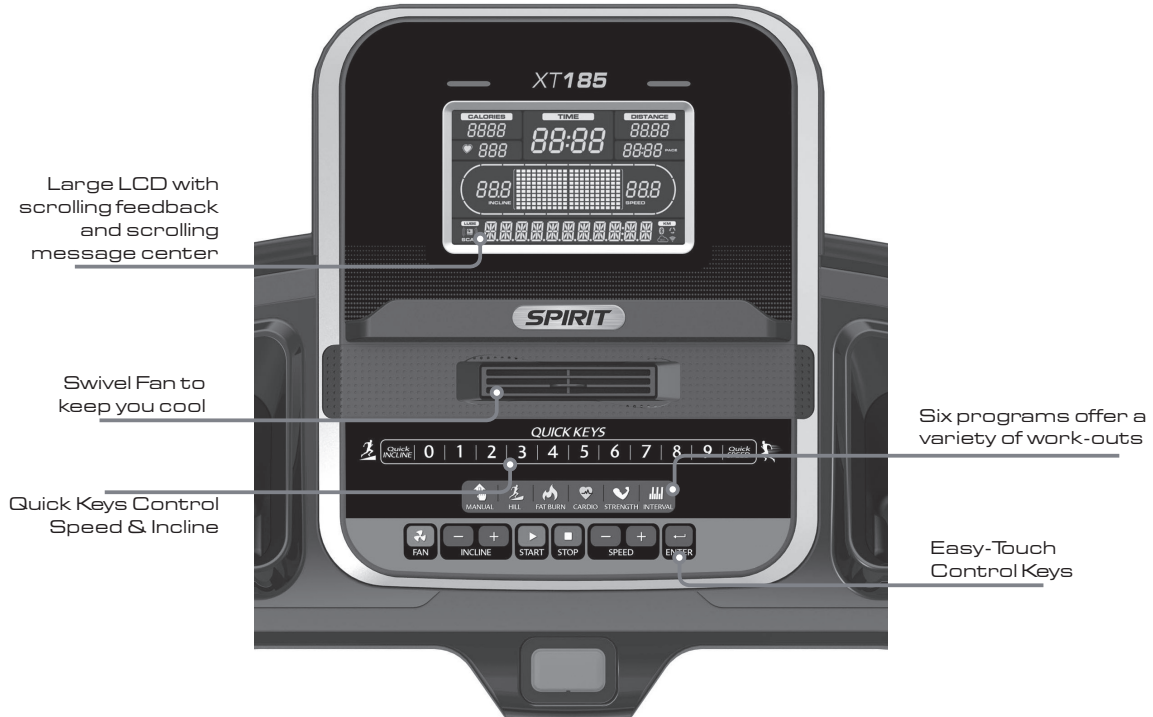

Quick Speed & Incline Buttons

You are able to set your speed and incline settings quickly by using the quick keys on the console. Just press either Speed or Incline, then select 2 digits, then press Enter and the treadmill will automatically adjust to that value. This saves time because you don't have to press and hold or hold a button down until reaching the desired value. The maximum value you may input for speed is 9.9 mph or KPH and incline level 9.5. Speed values can be entered in 0.1 mph increments and Incline in .5 level increments.

Examples:

Press the Quick Incline button, then 1, 0 = Incline Level 1.0 Press the Quick Incline button, then 3, 5 = Incline Level 3.5 Press the Quick Speed button, then 8, 0 = 8.0 mph or KPH Press the Quick Speed button, then 0, 8 = 0.8 mph or KPH

Console

The console will display Pace, Calories burned, Time (elapsed or countdown), Distance travelled, Pulse, Speed, Incline, Program Name, number of Laps completed, and Segment Time. There is also a Speed & Incline profile graph that lets you see how hard you have worked and how challenging the upcoming segments will be.

Getting Started

Power the treadmill on by plugging it into an appropriate wall outlet, then turn on the power switch located at the front of the treadmill below the motor cover. Ensure that the safety key is installed, as the treadmill will not power on without it.

When the power is turned on, all the lights on the display will light for a short time. Then the Time and Distance windows will display Odometer readings for a short time. The Time window will show how many hours the treadmill has been in use and the Distance window will show how many miles (or Kilometers if the treadmill is set to metric readings) the treadmill has gone. Then a message will scroll across the Message Center showing the current software version. The treadmill will then enter idle mode, which is the starting point for operation.

Quick Start/ Manual Operation

1. Press and release the Start key to wake display up (if not already on).
Note: Installing the tether key will also wake up the console.
2. Press and release the Start key to begin belt movement, at 0.5 mph, then adjust to the desired speed using the Speed + / - or Fast/Slow keys (console or hand rail). You may also use the quick speed key, then 0 through 9 to adjust the speed.
3. To adjust the speed, press and hold Speed Up / Down keys (console or handgrip keys) to achieve desired speed. You may also adjust to the desired speed by pressing Quick Speed and then 0 through 9.
4. To adjust the Incline level, press and hold the Incline Up / Down keys (console or handgrip keys) to achieve desired gradient. You may also adjust to the desired incline by pressing the Quick Incline key

and then 0 through 9.

5. To stop the tread-belt press and release the Stop key.

Pause/Stop/Preset

1. When the treadmill is running the pause feature may be utilized by pressing the red Stop key once. This will slowly decelerate the tread-belt to a stop. The incline will go to zero percent. The Time, Distance and Calorie readings will hold while the unit is in the pause mode. After 5 minutes the display will reset and return to the start up screen.
2. To resume your exercise, when in Pause mode, press the Start key. The speed and incline will return to their previous settings.
 - Pause is executed when the Stop button is pressed once. If the Stop key is pressed a second time, the program will end and a workout summary will be displayed. If the Stop button is pressed a third time, the console will return to the idle mode (start up) screen. If the Stop button is held down for more than 3 seconds the console will reset

Incline

1. Incline may be adjusted anytime after belt movement.
2. Press and hold the Incline Up / Down keys to achieve desired gradient. You may also choose a more rapid increase / decrease by selecting the Quick Incline key, then 0 through 9.
 - The display will indicate incline percent in increments of 0.5 as adjustments are made.
 - The incline will return to zero unless the main power switch or safety key are turned off while incline is at a higher setting.

Dot Matrix Center Display

Twenty columns of boxes (10 high) indicate each segment of a workout. The boxes only show an

approximate level (resistance) of effort. They do not necessarily indicate a specific value - only an approximate percent to compare levels of intensity. In Manual Operation the resistance dot matrix window will build a profile "picture" as values are changed during a workout.

1 / 4 Mile Track

The 1/4-mile track (one lap) will be displayed around the dot matrix window. The flashing segment indicates your progress. Once the 1/4-mile (Metric - 0.4k) is complete this feature will begin again. The Lap track will move in a counterclockwise direction. There is a lap counter in the message window for monitoring your distance.

Pulse Grip Feature

The Pulse (Heart Rate) window will display your current heart rate in beats per minute during the workout. You must use both stainless steel sensors on the stationary grips or the heart rate transmitter chest strap to display your pulse. Pulse value displays anytime the upper display is receiving a Pulse signal. You may not use the Pulse Grip feature while in Heart Rate Programs.

Note: Refer to Important Safety Instructions (page 4) concerning Pulse Grip operation.

Calorie Display

Displays the cumulative calories burned at any given time during your workout.

Note: This is only a rough guide used for comparison of different exercise sessions, and is not to be used for medical purposes.

To Turn Treadmill Off

1. Display will automatically turn off (go to sleep) after 30 minutes (no key operations).The treadmill will draw very little current in display mode (about as much as your screen when it is turned off).
2. Remove the tether cord.
3. Turn off the main switch on the front of the treadmill, below the motor cover.

Program Keys

The program keys are used to preview each program. When you first turn the console on you may press each program key to preview what the program profile looks like. If you decide that you want to try a program, press the corresponding program key and then press the **Enter** key to select the program and enter into the data-setting mode.

The treadmill has a built in heart rate monitoring system. Simply grasping the hand pulse sensors on the stationary handle bars or wearing the heart rate transmitter (see Using Heart Rate Transmitter section) will start the Heart Icon blinking (this may take a few seconds). The Pulse Display Window will display your heart rate, or Pulse in beats per minute.

The console includes a built-in fan to help keep you cool. To turn the fan on, press the key on the left side of the console.

Programming The Console

Each of the programs can be customized with your personal information and changed to suit your needs. Some of the information is necessary to ensure the readouts are correct. You will be asked for

your Age and Weight. Entering your Age is necessary during the Heart Rate programs to ensure the correct predicted target heart rate zone. Entering your Weight aides in calculating a more correct Calorie reading. Although we cannot provide an exact calorie count, we do want to be as close as possible.

CALORIE NOTE: Calorie readings on every piece of exercise equipment, whether it is in a gym or at home, are only an estimate and tend to vary widely. They are meant only as a guide to monitor your progress from workout to workout.

Entering A Program And Changing Settings

When you enter a program, by pressing a program key, then **Enter** key, you have the option of entering your own personal settings. If you want to workout without entering new settings, then just press the **Start** key. This will bypass the programming of data and take you directly to the start of your workout. If you want to change the personal settings then just follow the instructions in the Message Center. If you start a program without changing the settings, the default or saved settings will be used.

NOTE: Age and Weight default settings will change when you enter a new number. So the last Age and Weight entered will be saved as the new default settings. If you enter your Age and Weight the first time you use the treadmill, you will not have to enter it every time you work out unless either your Age or Weight changes, or someone else enters a different Age and Weight.

Each preset program has a maximum Speed and Incline level that is displayed when a desired workout is chosen. The maximum Speed and Incline that the particular program will achieve will be displayed in the Message Center.

To Select and Start A Preset Program

1. Press the desired program (**Hill, Fat Burn, Cardio, Strength, or Interval**) key. Press **Enter** to

select the program. The display will prompt you through the programming or you can just press Start to begin the program with default values.

2. If Enter was pressed, the Message Center will now be blinking a value, indicating your Age (default is 35). Entering your correct age affects the heart rate Bar Graph Display and the Heart Rate programs. Use the **+ / - keys** to adjust, then press **Enter**. Your age determines your recommended maximum heart rate. Since the Bar Graph Display and the Heart Rate features are based on a percentage of your maximum heart rate, it is important to enter the correct age for these features to work properly.
3. The Message Center will now be blinking a value, indicating your Body Weight (default is 150 lbs.). Entering the correct body weight will affect the calorie count. Use the **+ / - keys** to adjust, then press **Enter**.

A note about the Calorie display: No exercise machine can give you an exact calorie count because there are too many factors which determine exact calorie burn for a particular person. Even if someone is the exact same body weight, age and height, their calorie burn may be very different than yours. The Calorie display is to be used as a reference only to monitor improvement from workout to workout.

4. The Message Center will be blinking a value, indicating Time (the default value is 20 minutes). You may use any of the **+ / - keys** to adjust the time. After adjusting, or to accept the default, press Enter. (Note: You may press **Start** at any time during the programming to start the program).
5. The Message Center will now be blinking the preset top speed of the selected program (3.0 MPH). Use the **Speed + / - keys** to adjust, then press **Enter**. Each program has various speed changes throughout; this allows you to limit the highest speed the program can reach.
6. The Message Center will be blinking the preset top incline of the selected program. Use the Incline **+ / - keys** to adjust, then press **Enter**.

You are now done programming data and may press **Start** to begin your workout or **Enter** to go back one level to change data entered in the programming phase.

Preset Programs

The treadmill has five different programs that have been designed for a variety of workouts. These five programs have factory preset work level profiles for achieving different goals.

HILL

This program follows a triangle or pyramid type of gradual progression from approximately 10% of maximum effort (the level that you chose before starting this program) up to a maximum effort which lasts for 10% of the total workout time, then a gradual regression of resistance back to approximately 10% of maximum effort

Incline: The deck elevation is a more gradual and sustained progression. Maximum elevation is in the middle of the workout and lasts for 10% of the duration.

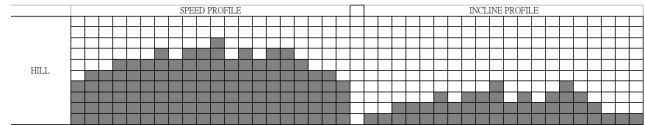

FAT BURN

This program follows a quick progression up to the maximum resistance level (default or user input level) that is sustained for 2/3 of the workout. This program will challenge your ability to sustain your energy output for an extended period of time.

Incline: The deck elevation is a quick and sustained progression up to the maximum value (default or user input) for 90% of the workout duration.

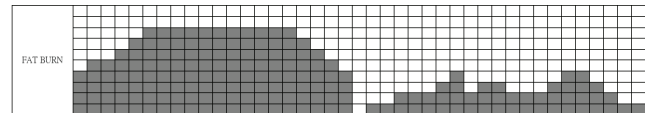

CARDIO

This program presents a quick progression up to near maximum resistance level (default or user input level). It has slight fluctuations up and down to allow your heart rate to elevate, and then recover repeatedly, before beginning a quick cool

down. This will build up your heart muscle and increase blood flow and lung capacity

Incline: The elevation in this program is moderate. There are several elevation spikes at different points of the workout. Segments 15 are maximum elevation for this program.

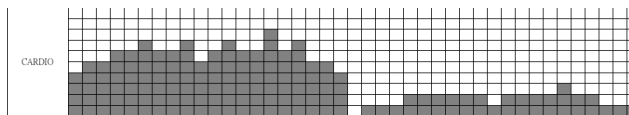

STRENGTH

This program has a gradual progression of resistance up to 100% of maximum effort that is sustained for 25% of workout duration. This will help build strength and muscular endurance in the lower body and glutes. A brief cool down follows.

Incline: There is a quick climb to a moderate, sustained elevation that lasts the majority of the workout length.

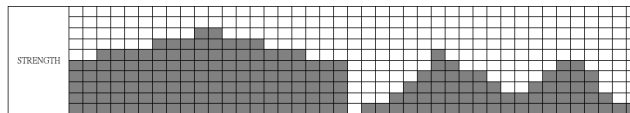

INTERVAL

This program takes you through high levels of intensity followed by recovery periods of low intensity. This program utilizes and develops your "Fast Twitch" muscle fibers which are used when performing tasks that are intense and short in duration. These deplete your oxygen level and spike your heart rate, followed by periods of recovery and heart rate drop to replenish oxygen. Your cardiovascular system gets programmed to use oxygen more efficiently.

Incline: This program will spike similar to the speed profile, but in different segments (columns); this means that all of your lower extremity muscles will be equally challenged throughout this program. The incline alternates between 25 & 65 % of maximum elevation

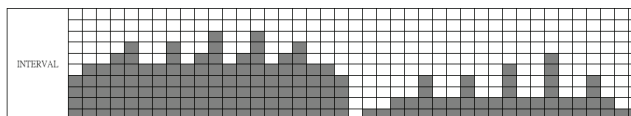

General Maintenance

Dirt, dust, and hair can block air inlets and accumulate on the running belt. Please vacuum underneath your treadmill on a monthly basis to prevent excess build-up of dirt that can get sucked up and get into the inner workings under the motor cover. Every other month, you should remove the motor cover and carefully vacuum out dirt and hair that may accumulate.

UNPLUG THE POWER CORD BEFORE THIS TASK.

(Please keep a record of your maintenance)

Belt Adjustments

Tread-belt Tension Adjustment - Belt tension is not critical for most users. It is very important though for joggers and runners in order to provide a smooth, steady running surface.

Adjustment must be made from the rear roller with the 6mm Allen wrench provided in the parts package. The adjustment bolts are located at the end of the step rails as shown in the diagram below.

Tighten the rear roller only enough to prevent slippage at the front roller. Turn the tread-belt tension adjusting bolts 1/4 turn each and inspect for proper tension by walking on the belt and making sure it is not slipping or hesitating with each step. When an adjustment is made to the belt tension, you must be sure to turn the bolts on both sides evenly or the belt could start tracking to one side instead of running in the middle of the deck.

DO NOT OVERTIGHTEN – Over tightening will cause belt damage and premature bearing failure. If you tighten the belt a lot and it still slips, the problem could actually be the drive belt - located under the motor cover - that connects the motor to the front roller. If that belt is loose it feels similar to the

walking belt being loose. Tightening the motor belt should be done by a trained service person.

Tread belt Tracking Adjustment

The treadmill is designed so that the tread-belt remains reasonably centered while in use. It is normal for some belts to drift near one side while in use, depending on a user's gait and if they favor one leg. But if during use the belt continues to move toward one side, adjustments are necessary.

Setting Tread-belt Tracking

A 6mm Allen wrench is provided for this adjustment. Make tracking adjustments on the left side bolt. Set belt speed at 3 mph. Be aware that a small adjustment can make a dramatic difference which may not be apparent right away. If the belt is too close to the left side, then turn the bolt only a 1/4 turn to the right (clockwise) and wait a few minutes for the belt to adjust itself. Continue to make 1/4 turns until the belt stabilizes in the center of the running deck.

If the belt is too close to the right side, turn the bolt counter-clockwise. The belt may require periodic tracking adjustment depending on use and walking/running characteristics. Some users may affect tracking differently. Expect to make adjustments as required to center the tread-belt. Adjustments will become less of a maintenance concern as the belt is used. Proper belt tracking is an owner responsibility common with all treadmills.

ATTENTION

Damage to the running belt resulting from improper tracking / tension adjustments is not covered under the Spirit Fitness warranty.

Belt/Deck Lubrication Procedure

First, you want to clean between the belt and deck to remove any debris that may be trapped. Use a clean, non-fraying rag, t-shirt, or light towel. Halfway between the end of the treadmill and motor cover, shove the garment under the belt until you can grasp it on both sides of the belt. Drag the garment the length of the entire belt 1-2 times. Remove the garment.

Do not lubricate with anything other than Spirit Fitness approved lubricant. Your treadmill comes with one tube of “Lube” and extra tubes can be ordered directly from Spirit Fitness or your authorized Spirit Fitness dealer. You may also use a Lube-n-Walk kit that can be purchased through both aforementioned sellers.

Keeping the deck lubricated at the recommended intervals ensures the longest life possible for your treadmill. If the lubricant dries out, the friction between the belt and deck rises and places undue stress on the drive motor, drive belt and electronic motor control board, which could result in catastrophic failure of these expensive components. Failure to lubricate the deck at regular intervals may void the warranty.

The belt & deck come pre-lubricated and subsequent lubrication should be performed every 180 hours of use or if you notice that the deck is dry. It is recommended that you reach between the belt and deck to verify there is lubrication present, every other month. If you check and there isn't any lubrication present, follow the procedure below even though the “Lube” indicator isn't lit on the console. Otherwise, lubricate when the console's lubrication reminder lights after 180 hours of use. Use the following procedure to apply the silicone lubricant:

1. Turn the power switch off and unplug the power cord from the wall outlet
2. Measure 18" from the edge of the motor cover; kneel down and reach under the belt approximately 4- 6" from one edge. Squirt a line of lubricant about 1/8" wide x 15" long in an "S" pattern perpendicular to the motor cover.
3. Repeat the process on the opposite side.
4. Plug the electrical cord back into the outlet and turn the power switch on.
5. Walk on the belt at a moderate speed for five minutes to evenly distribute the silicone lube.
Note: If the "Lube" message appears on the console, perform the following procedure to reset the message:
 - To enter the Engineering Mode Menu press and hold down the Start, Stop and Enter keys, then at the same time insert the safety key. Keep holding the keys down until the Message Center displays Engineering Mode Menu. Press the Enter button to access
 - Press the Speed + button (or Speed – button to go backwards) until "Functions" appears; press Enter
 - Press the Speed + button until "Maintenance" message appears; press Enter
 - Press Stop to exit Engineering mode and resume use of your treadmill

Calibration Procedure

1. Remove the Safety Key.
2. Press and hold **Start** and **Speed _** buttons and at the same time replace the Safety Key. Continue to hold Start and Speed _ keys until the window displays "Factory settings", then press the **Enter** key.
3. You will now be able to set the display to show Metric or English settings (Miles vs. Kilometers). To do this, press the **incline Up/ Down key** to show which you want, then press **Enter** (The maximum speed value is displayed in the speed window, and the maximum elevation value is displayed in the incline window.)
4. Grade return – On (This allows the incline to return to zero when Stop button is pressed. For sale in Europe, EU standards require this to be off)
5. Press **Start** button to begin calibration. The process is automatic; the speed will start up without warning, so do not stand on the belt.

Adjusting the Speed Sensor

If the calibration does not pass you may need to check the speed sensor alignment.

1. Remove the motor cover hood by loosening the 4 screws that hold it in place (you do not need to remove them completely).
2. The speed sensor is located on the left side of the frame, right next to the front roller pulley (the pulley will have a belt around it that also goes to the motor). The speed sensor is small and black with a wire connected to it.
3. Make sure the sensor is as close as possible to the pulley without touching it. You will see a magnet on the face of the pulley; make sure the sensor is aligned with the magnet. There is a screw that holds the sensor in place that needs to be loosened to adjust the sensor. Re-tighten the screw when finished.

Engineering Mode Menu

The console has built in maintenance/diagnostic software. The software will allow you to change the console settings from English to Metric and turn off the beeping of the speaker when a key is pressed for example. To enter the Engineering Mode Menu, press and hold down the **Start**, **Stop** and **Enter** keys. Keep holding the keys down for about 5 seconds and the Message Center will display Engineering Mode Menu. Press the **Enter** key to access the menu below:

1. Key Test (Will allow you to test all the keys to make sure they are functioning)
2. Display Test (Tests all the display functions)
3. Functions (Press **Enter** to access settings; use the Speed Up and Down keys to scroll)
 - I. Display Mode (Turn off to have the console power down automatically after 30 minutes of inactivity)
 - II. Pause Mode (Turn on to allow 5 minutes of pause, turn off to have the console pause indefinitely)
 - III. Maintenance (Reset lube message and odometer readings)
 - IV. Units (Sets the display to readout in English or Metric display measurements)
 - V. Key Tone (Turns off the speaker so no beeping sound is heard)
4. Security (Allows you to lock the keypad so no unauthorized use of the machine is allowed. When the child lock is enabled, the console will not allow the keypad to operate unless you press and hold the Start and Enter buttons for 3 seconds to unlock the console.)
5. Exit

Service Checklist Diagnosis Guide

Problem	Solution/ Cause
Display does not light	<ol style="list-style-type: none"> 1. Tether cord not in position. 2. Circuit breaker on front grill tripped. Push circuit breaker in until it locks. 3. Plug is disconnected. Make sure plug is firmly pushed into 115 VAC wall outlet. 4. Breaker panel circuit breaker may be tripped. 5. Treadmill defect. Contact your Spirit Fitness dealer.
Tread-belt does not stay centered Treadmill belt hesitates when walked/ run on	The user may be walking while favoring or putting more weight on either the left or right foot. If this walking pattern is natural, track the belt slightly off-center to the side opposite from the belt movement. See General Maintenance section on Tread-belt Tension. Adjust as necessary.
Motor is not responsive after pressing start	<ol style="list-style-type: none"> 1. If the belt moves, but stops after a short time and the display shows "E1", run calibration. 2. If you press Start and the belt never moves, then the display shows E1, contact service.
Treadmill will only achieve approximately 7mph but shows higher on the display	This indicates motor should be receiving power to operate. Low AC voltage to treadmill. Do not use an extension cord. If an extension cord is required it should be as short as possible and heavy duty 16 gauge minimum. Low voltage. Contact an electrician or your Spirit Fitness dealer. A minimum of 110 volt AC current is required.
Tread-belt stops quickly/suddenly when tether cord is pulled	High belt/deck friction. See General Maintenance section on cleaning the deck. If cleaning doesn't prevent this from reoccurring, check to see if there is significant wear of the deck. If so, the deck may need to be flipped if it is on its original side
Treadmill trips on board 15 amp circuit	High belt/deck friction. See General Maintenance. If cleaning doesn't prevent this from reoccurring, check the amp draw of the motor. If this is high and there are signs of significant wear of the deck, it may need to be flipped if it is on its original side
Computer shuts off when console is touched (on a cold day) while walking/running	Treadmill may not be grounded. Static electricity is "crashing" the computer. Refer to Grounding Instructions.
Circuit breaker trips, but not the treadmill circuit breaker	Need to replace the breaker with a "High In-rush current" type breaker (see page 6 for details)

Treadmill Warranty - Effective February 4, 2016

Spirit Fitness, Inc. (Spirit Fitness) warrants all its treadmill parts for a period of time listed below from the date of retail sale, as determined by sale receipt, or in the absence of a sales receipt eighteen (18) months from the original factory shipping date. Spirit Fitness' responsibilities include providing new or remanufactured parts, at Spirit Fitness' option, and technical support to our independent dealers and servicing organizations. In the absence of a dealer or service organization, these warranties will be administered by Spirit Fitness directly to a consumer. The warranty period applies to the following components:

Warranty	Frame	Motor	Deck	Parts	Labor
Residential	Lifetime	Lifetime	Lifetime	5 Years	1 Year

NORMAL RESPONSIBILITIES OF THE CONSUMER

This warranty applies only to products in ordinary household or Light Commercial use (see restrictions above), and the consumer/facility is responsible for the items listed below:

1. The warranty registration card must be completed and returned to the address listed on the card within 10 days of the original purchase to validate the manufacturer's limited warranty.
2. Proper use of the treadmill in accordance with the instructions provided in this manual
3. Proper installation in accordance with instructions provided with the treadmill and with all local electric codes.
4. Expenses for making the treadmill accessible for servicing, including any item that was not part of the treadmill at the time it was shipped from the factory.
5. Damages to the treadmill finish during shipping, installation or following installation.
6. Routine maintenance of this unit as specified in this manual.

EXCLUSIONS

This warranty does not cover the following:

1. CONSEQUENTIAL, COLLATERAL, OR INCIDENTAL DAMAGES SUCH AS PROPERTY DAMAGE AND INCIDENTAL EXPENSES RESULTING FROM ANY BREACH OF THIS WRITTEN OR ANY IMPLIED WARRANTY.
Note: Some states do not allow the exclusion or limitation of incidental or consequential damages, so this limitation or exclusion may not apply to you.
2. Service call reimbursement to the consumer: Service call reimbursement to the dealer that does not involve malfunction or defects in workmanship or material, for units that are beyond the warranty period, for units that are beyond the service call reimbursement period, for treadmill not requiring component replacement, or treadmill not in ordinary household or light commercial use.
3. Damages caused by services performed by persons other than authorized Spirit Fitness service companies; use of parts other than original Spirit Fitness parts; or external causes such as corrosion, discoloration of paint or plastic, alterations, modifications, abuse, misuse, accident, improper maintenance, inadequate power supply, or acts of God.
4. Products with original serial numbers that have been removed or altered.

5. Products that have been: sold, transferred, bartered, or given to a third party.
6. Products that do not have a warranty registration card on file at Spirit Fitness. Spirit Fitness reserves the right to request proof of purchase if no warranty record exists for the product.
7. THIS WARRANTY IS EXPRESSLY IN LIEU OF ALL OTHER WARRANTIES EXPRESSED OR IMPLIED, INCLUDING THE WARRANTIES OF MERCHANTABILITY AND/OR FITNESS FOR A PARTICULAR PURPOSE.
8. Product use in any environment other than a residential setting or non-dues paying facility with 5 hours use or less per day.
9. Warranties outside of the United States may vary. Please contact your local dealer for details.

SERVICE

Keep your bill of sale. Twelve (12) months from the date on the bill of sale or eighteen (18) months from the date of factory shipping as determined by the serial number establishes the labor warranty period should service be required. If service is performed, it is in your best interest to obtain and keep all receipts. This written warranty gives you specific legal rights. You may also have other rights that vary from state to state. Service under this warranty must be obtained by following these steps, in order:

1. Contact your selling authorized Spirit Fitness dealer. OR
2. Contact your local authorized Spirit Fitness service organization.
3. If there is a question as to where to obtain service, contact our service department at (870) 935-1107.
4. Spirit Fitness' obligation under this warranty is limited to repairing or replacing, at Spirit Fitness' option, the product through one of our authorized service centers. All repairs must be preauthorized by Spirit Fitness. If the product is shipped to a service center freight charges to and from the service center will be the customer's responsibility. For replacement parts shipped while the product is under warranty, the customer will be responsible for shipping and handling charges. For in-home service, the customer will be responsible for a trip charge. There will be an additional trip charge if the customer is located over 100 miles from the nearest service center.
5. The owner is responsible for adequate packaging upon return to Spirit Fitness. Spirit Fitness is not responsible for damages in shipping. Make all freight damage claims with the appropriate freight carrier: DO NOT SHIP ANY UNIT TO OUR FACTORY WITHOUT A RETURN AUTHORIZATION NUMBER. All units arriving without a return authorization number will be refused.
6. For any further information, or to contact our service department by mail, send your correspondence to:

Spirit Fitness, Inc.
PO. Box 2037
Jonesboro, AR 72402-2037

Product features or specifications as described or illustrated are subject to change without notice. All warranties are made by Spirit Fitness, Inc. This warranty applies only in the 48 contiguous United States. NOTE: This does not apply to Alaska or Hawaii.



800.258.4555
spiritservice@spiritfitness.com
www.spiritfitness.com



Spirit Fitness
3000 Nestle Road
Jonesboro, AR 72401

SPIRIT

XT185 Owners Manual
© 2016 All Rights Reserved
Revision: 10.13.2016