

Orux 700 Z

LED Moving Beam/Spot



User Manual



Table of Contents

1. Introduction and Setup.....	3
Unpacking and In the Box.....	3
Mounting and Operation.....	3
Power Connection.....	4
Features.....	4
Safety Precautions.....	5
Customer Support.....	5
2. Setup and Operation.....	7
Using the LCD Menu and Buttons.....	7
Menu Operation.....	7
DMX Setup.....	8
DMX Basics.....	9
DMX Wiring.....	9
DMX Modes and Configuration.....	11
3. Maintenance.....	16
Routine Maintenance.....	16
Troubleshooting Problems.....	16
A. The unit does not work:.....	16
B. Not Responding to the DMX Controller.....	16
4. Technical Specifications.....	17
Photometric Reports.....	17

1. Introduction and Setup

The ORUX 700 is a full-featured Profile moving head featuring a variety of advanced features including CMY Color Mixing, multiple gobo wheels, color wheel, prism, zoom, frost, and more!

Unpacking and In the Box

Unpacking:

- Remove the fixture carefully from the box.
- Release the pan and tilt locks before using.

In the box, you'll find:

- (1) GAMMA Orux 700w
- (1) DMX 3-Pin Cable
- (2) Included Clamps attached to fixture.
- (1) PowerCon Power Cable

Mounting and Operation

Before installation, please read the user manual carefully, then prepare the fixture and a Safety Cable (1 pc).

Clamp Mounting: The Orux 700 provides a unique mounting bracket assembly that integrates the bottom of the base with clamps that swivel into place.

As an added safety measure be sure to attached at least one properly rated safety cable to the fixture using on of the safety cable rigging point integrated in the base assembly. The safety attachment point shall be rated for 10x the weight of the fixture and all accessories.

Power Connection

This fixture is equipped with an auto-switching power supply that automatically adjusts to any 50-60Hz AC power source from 100-240 volts. The fixture is protected by one 12a primary blow fuse (5mmx20)

The locking connector is connected and disconnected as shown:

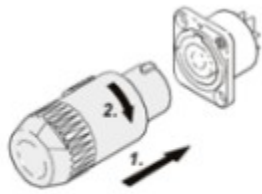

Connect the power cable



discharge the power cable

You may need to install or modify the connector that ships with the ORUX 700 to meet your needs. A 3-prong grounding-type plug must be installed following the manufacturer’s instructions. If you have any doubts about the proper installation, consult a qualified electrician.

The wire color-code is as follows:

Core (EU)	Core (US)	Connection	Plug Terminal Marking
Brown	Black	Live	L
Light blue	White	Neutral	N
Yellow/Green	Green	Earth	

To apply power once connected, set the power switch on the base of the fixture to the “ON” position.

Features

- ◆ 700w LED Spot and Beam light with color mixing.
- ◆ DMX Channels: 39 and 34 DMX channel modes.
- ◆ Operation modes: DMX 512 with RDM
- ◆ Perfect for stage, theatre, church, studio, and more!
- ◆ Color Wheel with 8 colors + white.
- ◆ Fixed Gobo Wheel with 7 Gobos, Rotating Gobo Wheel with 7 Gobos and Animation Wheel located on Gobo Wheel 2.
- ◆ 3 Pin and 5 Pin DMX Connections
- ◆ Weight: 32kg / 71 lbs
- ◆ Beam Angle:5°~45° Motorized Zoom

Included Gobos:

Gobo Wheel 1:

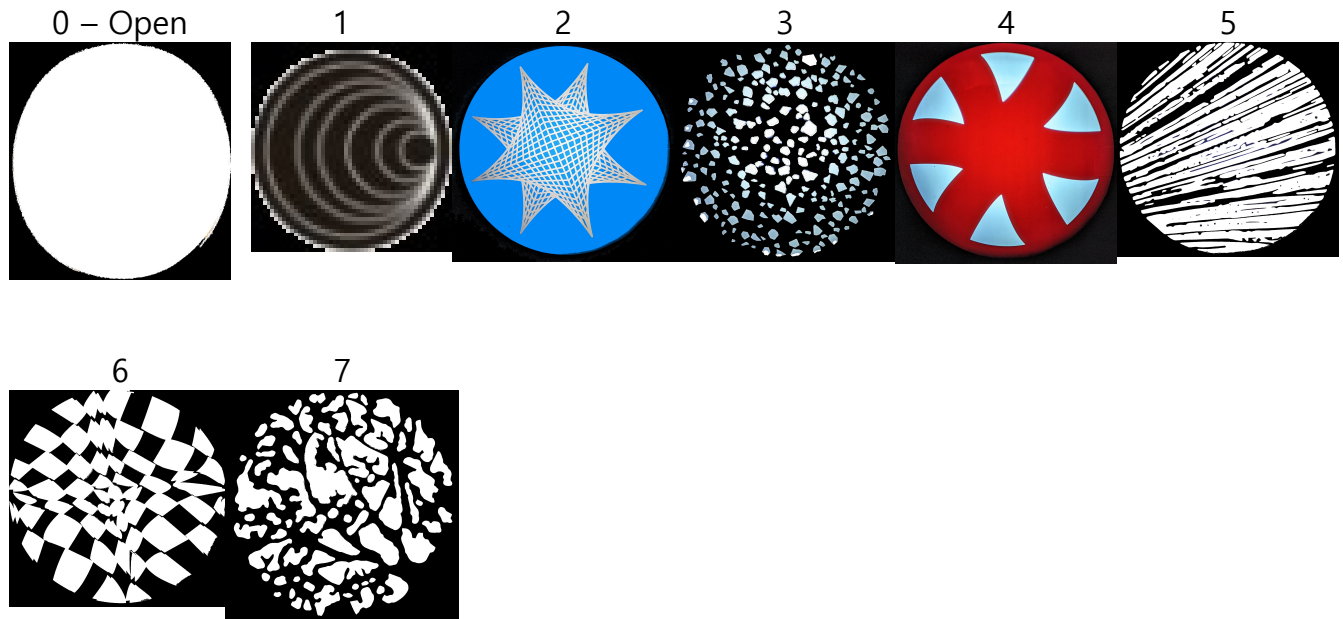

Gobo Wheel 2:



Animation Wheel:

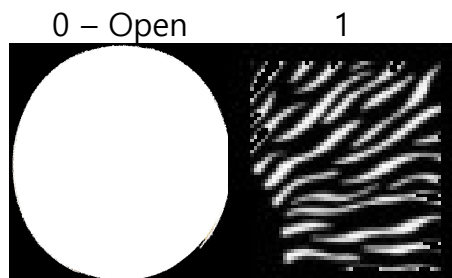

Safety Precautions

The ORUX 700 is a professional grade stage light. Please read the following safety tips carefully and obey the safety noticed of this light before installation, use, and maintenance.

Please disconnect power before opening or cleaning the fixture.

Make sure the power supply is connected to an appropriate ground before use. Make sure all cables supplying power are adequate for the load required.

If the cables, plug, or any part of the fixture are damaged, do not use the fixture until it is repaired.

Don't use this fixture in wet environments.

Keep flammable objects .2 meters from the fixture at all times.

Keep flammable objects 2.5 meters away when illuminated by the fixture.

Don't carry this fixture by yourself.

Install the light on flat surfaces or level hanging points.

Customer Support

- GAMMA LED VISION LLC warrants this product for a period of twelve (12) months from the date of purchase or date of manufacture*, to be free from defects in material and workmanship.

**The date of manufacture will be used as the warranty period start date in cases where there is greater than a twelve (12) month difference between the date of manufacture and the date of purchase.*

Example: if a product having a manufacture date of JANUARY 2020 is purchased in MARCH 2022 the warranty period will commence in JANUARY 2020 .

- This limited warranty is valid only for the original purchaser, is not transferable and is only applicable to products sold within the 50 STATES OF THE UNITED STATES OF AMERICA .

For products purchased outside the UNITED STATES OF AMERICA , WARRANTY DOES NOT APPLY, please check with your designated dealer in that region.

- Please visit WWW.GAMMALEDVISION.COM for complete Limited Warranty terms and contact information.

2. Setup and Operation

On the base of the ORUX 700 we see the following connection points for power and data:

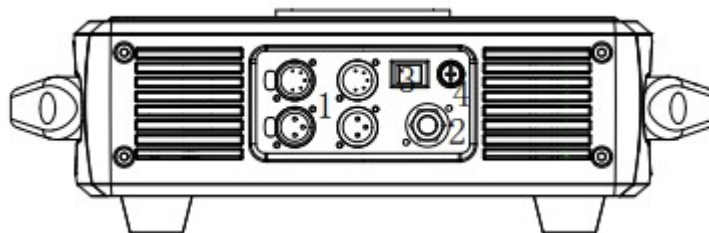

1. DMX Connections
2. Power Connection
3. Power Switch
4. Fuse Socket

Using the LCD Menu and Buttons

On the opposite side from the connections is the LCD Menu:



Menu Operation

The on-board menu allows you to setup the light to your needs. The ORUX 700 is also RDM enabled for remote setup, configuration, and monitoring.

MENU	Address	DMX Address	Set DMX Address, 1-512
	Work Mode	DMX Mode	Set the signal mode, the only option is DMX mode for this fixture.
	CH Mode	Set the DMX Channel Mode	39 CH Mode1– Default Mode
			14 CH Mode2– Simplified Mode
	Test Mode	Sets the unit in TEST mode – allowing you to manually scroll and set values for each parameter of the light.	
	XY Setup	Allows you to invert and modify the pan and tilt.	X Invert: Inverts the pan of the light.
			Y Invert: Inverts the tilt of the light.
			XY Speed: Can be used to slow down the speed of the light. Default is “High”.
	Signal	Allows you to see a readout of the DMX values being received.	
	System	Allows you to change system-wide settings.	Backlight Time
Screen Direction			
Language – English or Chinese – CHANGE WITH CAUTION!			
Reset	Does a re-homing of the unit.		

DMX Setup

DMX Basics

DMX512 stands for digital multiplex 512. This means that 512 channels are controlled digitally through 1 data cable.

A channel is a set of 255 steps that are assigned to control attributes in each light. This may be a color like red, green or blue, and intensity, strobe, pan/tilt or other attributes.

Multiple sets of 512 “universes” may be used. Only 1 universe will travel on a DMX cable, but through networked DMX (Art-Net or sACN E1.31), many universes can travel over a network.

DMX Wiring

DMX works by connecting 1 or multiple lights to the output of a DMX lighting console or software with a DMX interface.

DMX lights connect in what is called a “daisy-chain”. Your first DMX cable will plug its male DMX connector into the female DMX connector on your lighting console. The remaining female connector will then connect to the DMX input on your first light.

You may then connect your next fixture to the output of your first light, and continue the

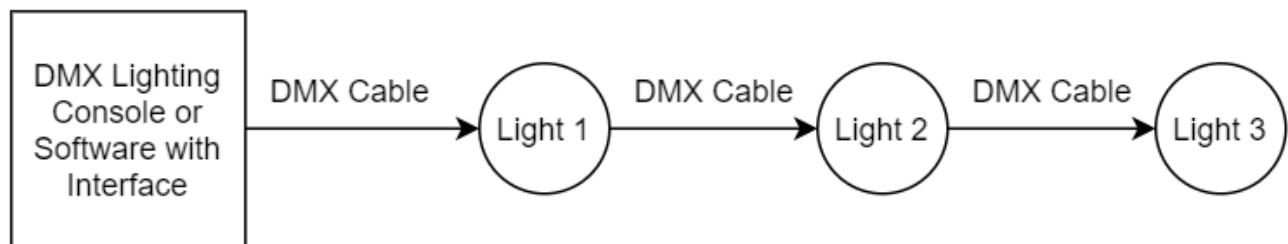

chain.

32 Fixture Rule – DMX only allows you to connect up to 32 fixtures in a single daisy chain for signal strength. Sometimes, depending on the fixtures and cable length, this number is less (or more).

DMX Cables can be 3-pin or 5-pin. These use the same type of data, and in the 5-pin only pins 1, 2, and 3 are used. The cable should be a 2 conductor, shielded cable of at least 110 ohms resistance. Microphone cable is not DMX cable.

Please refer to the diagram below:

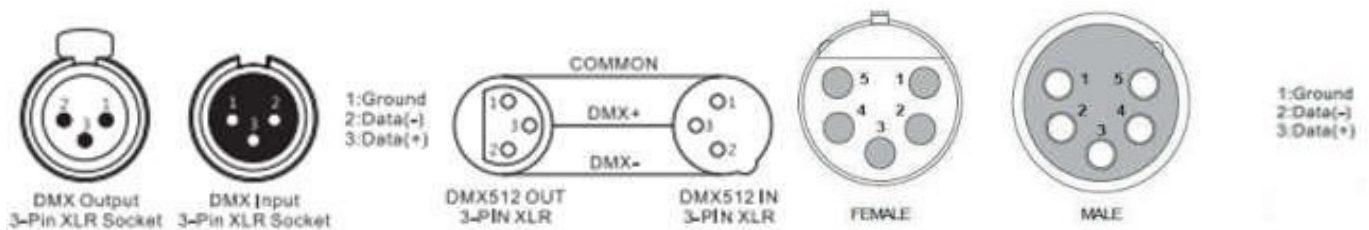

For installations where the DMX cable has to run a long distance or is in an electrically noisy environment, it is recommended to use a DMX terminator. This helps in preventing corruption of the digital control signal by electrical noise and reflections. The DMX terminator is simply an XLR plug with a 120 Ω resistor connected between pins 2 and 3, which is then plugged into the output XLR socket of the last fixture in the chain. Please see illustrations below:

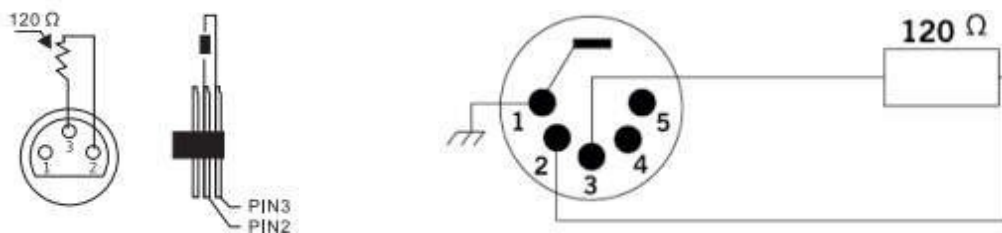

DMX Modes and Configuration

Orux 700 has multiple DMX modes, sometimes called "personalities", "profiles", or as we will use here "modes".

In general, modes with more DMX channels offer a greater level of control or options but take up more of your output channels on your lighting console or software.

Modes with less DMX channels often offer less control, but may be plenty for your needs.

Depending on your needs and control solution, you may not need channels for automated programs, strobes, or macros – your console may have great effects! In this case, you can use a lesser channel mode and fit more lights per DMX universe.

View the DMX mode charts below to find the mode that best suits your needs.

39 CH Mode 1	34 CH Mode 2	Function	Value	Detailed information
1	1	Dimmer	0-255	Dimmer Control
2		Dimmer Fine	0-255	Dimmer Fine Control
3	2	Strobe	0-7	Open
			8-65	Pulse, Slow to Fast
			66-195	Open
			196-250	Strobe, Slow to Fast
			251-255	Open
4	3	Color Wheel	0-10	Open
			11-21	Open-Red
			22-32	Red

			33-42	Red-Green
			43-53	Green
			54-65	Green-Pink
			66-75	Pink
			76-86	Pink-Cyan
			87-97	Cyan
			98-108	Cyan-Orange
			109-119	Orange
			120-129	Orange-Lime
			130-141	Lime
			142-152	Lime-Yellow
			153-063	Yellow
			164-174	Yellow-Royal Blue
			175-185	Royal Blue
			186-196	Royal Blue-Open
			197-226	Color Scroll CW, Slow to Fast
			227-255	Color Scroll CCW, Fast to Slow
5	4	Cyan	0-255	Cyan Color Mixing
6	5	Magenta	0-255	Magenta Color Mixing
7	6	Yellow	0-255	Yellow Color Mixing
8	7	CTC	0-255	Color Temperature Control, 6500k-2800k, Linear
9		Static Color	0-255	Static Color Macros using the CMY

		Macro		System
10	8	Iris	0-128	Max-Min Iris
			129-131	Closed
			132-171	Pulse, Slow-Fast
			172-211	Slow Pulse Fast Close – Fast Pulse, Slow Close
			212-251	Slow Pulse Fast Open – Fast Pulse Fast Open
			252-255	Open
11	9	Gobo Wheel 1 – Rotating Gobos	0-5	Open
			6-10	Gobo 1
			11-16	Gobo 2
			17-22	Gobo 3
			23-28	Gobo 4
			29-34	Gobo 5
			35-40	Gobo 6
			41-52	Gobo 7
			53-70	Gobo 1 Shake, Slow to Fast
			71-88	Gobo 2 Shake, Slow to Fast
			89-106	Gobo 3 Shake, Slow to Fast
			107-124	Gobo 4 Shake, Slow to Fast
			125-142	Gobo 5 Shake, Slow to Fast
			143-160	Gobo 6 Shake, Slow to Fast

			161-178	Gobo 7 Shake, Slow to Fast
			179-217	Gobo Cycle CW, Fast to Slow
			218-255	Gobo Cycle CCW, Fast to Slow
12	10	Gobo 1 Rotation	0-127	Gobo 1 Index
			128-191	Gobo 1 Rotate CW, Slow to Fast
			192-255	Gobo 1 Rotate CCW, Fast to Slow
13		Gobo 1 Rotation Fine	000-255	Fine Control for Gobo Rotation
14	11	Gobo Wheel 2 – Fixed Gobos	0-4	Open
			5-10	Gobo 1
			11-16	Gobo 2
			17-22	Gobo 3
			23-28	Gobo 4
			29-44	Gobo 5
			45-50	Gobo 6
			51-71	Gobo 1 Shake, Slow to Fast
			72-92	Gobo 2 Shake, Slow to Fast
			93-113	Gobo 3 Shake, Slow to Fast
			114-134	Gobo 4 Shake, Slow to Fast
			135-155	Gobo 5 Shake, Slow to Fast
			156-176	Gobo 6 Shake, Slow to Fast
			177-216	Gobo Scroll CW, Slow to Fast
			217-255	Gobo Scroll CCW, Fast to Slow

15	12	Frame 1a	0-255	
16	13	Frame 1b	0-255	
17	14	Frame 2a	0-255	
18	15	Frame 2b	0-255	
19	16	Frame 3a	0-255	
20	17	Frame 3b	0-255	
21	18	Frame 4a	0-255	
22	19	Frame 4b	0-255	
23	20	Framing Rotation	0-255	Framing Shutter Rotation
24	21	Animation Wheel	0-192	Open
			193-255	Animation, Slow to Fast
25	22	Reserved		
26	23	Frost	0-127	Open
			128-255	Frost Inserted
27	24	Prism – 8 Facet Prism	0-127	Open
			128-255	Prism Inserted
28	25	Prism Rotate	0-127	Index
			128-190	Rotate CW, Fast to Slow
			191-194	Stop
			195-255	Rotate CCW, Slow to Fast
29	26	Focus	0-255	
30		Focus Fine	0-255	

31	27	Zoom	0-255	
32		Zoom Fine	0-255	
33	28	Pan	0-255	
34	29	Pan Fine	0-255	
35	30	Tilt	0-255	
36	31	Tilt Fine	0-255	
37	32	Pan/Tilt Speed	0-128	Fast to Slow
			129-170	1/3 Speed, Slow
			171-211	½ Speed, Medium
			212-255	Fastest Speed
38	33	Reserved		
39	34owa	Control	0-231	Reserved
			232-255	Reset ALL (>3s)

3. Maintenance

Routine Maintenance

Troubleshooting Problems

The following are a few common problems that may occur during operation. Here are some suggestions for easy troubleshooting:

A. The unit does not work:

- Check that the unit is plugged in to a working power connector.
- Press the menu button to confirm that the unit is powered on. If the screen does not light up, the unit has no power.

B. Not Responding to the DMX Controller

- Check DMX cables to verify that they are plugged in and functional.
- Check the DMX address and mode – does it match the address and mode patched in the lighting console or software?
- Plug the light directly into the DMX controller with a cable that you know is good. Unplug all other lights – does it work?
- Try to use another DMX controller.

4. Technical Specifications

Power Supply

- AC 100 ~ 240V 50/60Hz

1. Input Power

- 800W@220V

1. Lamp Source

- Type: 680W LED lamp
- Average Life: More than 20000 hours.
- Light source color: 6800K

1. Color System

- One color wheel with 8 color filters.

1. Effects

- 2 gobo wheels, one wheel with 6 metal gobos. Other is a rotating gobo wheel, with 7 interchangeable gobo filters. Gobo indexing, bidirectionally rotation and with flowing and shaking effect.
- 1 Interchangeable 8-facet Prism
- 1 Separate flexible light mirror
- Electronic strobe, 0-100% linear dimming, extremely smoothing for dimming
- Electronic linear zoom 5°-45°

1. Control & Programming

- Standard Mode: 39Channels, Simplified Mode: 34 Channels
- DMX protocol signal: USITT DMX 512

Art-Net / RDM

Wireless DMX512

- DMX signal connection: 3 and 5 pole XLR input and output
- Pan/Tilt Resolution: 16 bit
- Dimmer Resolution: 16 bit

1. Fixture Body

- Two side handles for transportation
 - PAN and TILT lock for transport and maintenance
8. LCD Display, HMI user-friendly, Language: English

9. Moving Feature

- Angle:
 - PAN = 540°
 - TILT = 245°
- Automatic auto positioning of PAN and TILT after accidental movement not controlled by control unit

1. Electronics

- Electronic control engine.
- Fan speed control: Intelligently automatic fan speed adjustable.
- Temperature electronic sensor detection.
- LCD screen lighting information inquiry.
- Up to GB7000.217-2008 standard and CE Certification

1. Weight

- Net Weight: 32Kg

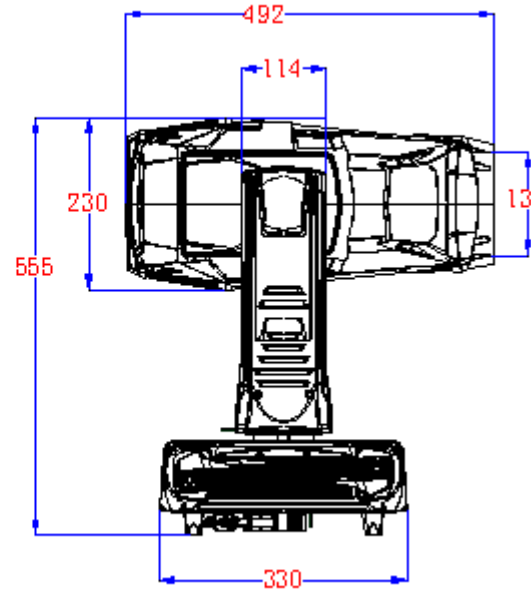
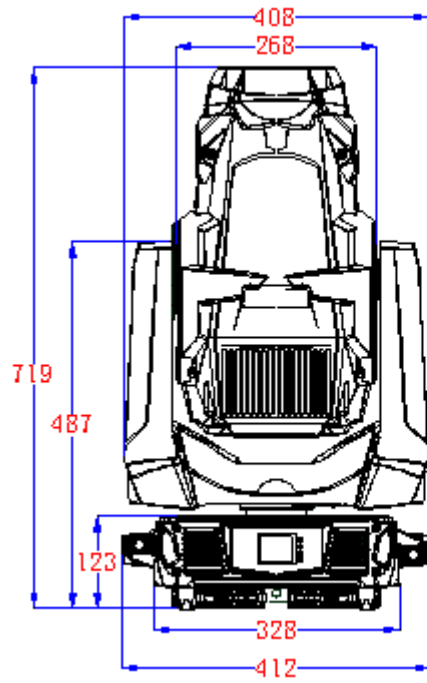

Photometric Reports

Distance	FC – Zoom In	FC – Zoom Out
10'	25000	579
15'	11100	242
25'	3470	102