

CRE, CRIE, CRNE

50/60 Hz

Vertical multistage centrifugal E-pumps



1. Introduction	3	CRIE, CRNE 20	63
Examples of E-pump applications	3	CRE 32	65
When to select an E-pump	4	CRNE 32	67
Components of a Grundfos E-pump	4	CRE 45	69
E-pumps with and without a sensor	4	CRNE 45	71
ErP compliant	5	CRE 64	73
2. Applications	6	CRNE 64	75
3. Features and benefits	7	CRE 95	77
Pump	7	CRNE 95	79
Motor	7	CRE 125	81
4. Performance range	13	CRNE 125	83
5. Product range	14	CRE 155	85
6. Identification	16	CRNE 155	87
Type key	16	11. Motor data	89
7. Construction	18	E-motors, 50/60 Hz	89
CRE 1, 3, 5, 10, 15, 20	18	12. Accessories	90
CRIE 1, 3, 5, 10, 15, 20	19	Pipe connection	90
CRNE 1, 3, 5, 10, 15, 20	20	Adapter kit	90
CRE 32, 45, 64	21	Potentiometer	99
CRNE 32, 45, 64	22	EMC filter	99
CRE 95, 125, 155	23	LiqTec	99
CRNE 95, 125, 155	24	Kit, sensor cpl. MkII	99
8. Operating conditions	25	Sensors	100
Pumped liquids	25	Adjustable anti-vibration feet	102
Viscosity	28	Remote controls	102
Maximum operating pressure and liquid temperature	29	CIM communication interface modules	102
Operating range of the shaft seal	30	13. Variants	103
Maximum inlet pressure	31	14. Grundfos Product Center	105
Control of E-pumps	32	Grundfos GO	106
9. Selection	35	15. Document quality feedback	107
Selection of pumps	35		
How to read the curve charts	39		
Guidelines to performance curves	40		
10. Performance curves and technical data ..	41		
CRE 1	41		
CRIE, CRNE 1	43		
CRE 3	45		
CRIE, CRNE 3	47		
CRE 5	49		
CRIE, CRNE 5	51		
CRE 10	53		
CRIE, CRNE 10	55		
CRE 15	57		
CRIE, CRNE 15	59		
CRE 20	61		

1. Introduction



CRE, CRIE and CRNE pumps

The CRE, CRIE and CRNE pumps are based on the CR, CRI and CRN pumps.

CRE, CRIE and CRNE pumps belong to the so-called E-pump family and are referred to as E-pumps.

The difference between the CR and CRE pump ranges is the motor.

E-pumps are fitted with an E-motor, meaning a motor with a built-in frequency converter.

The E-pump motor is a Grundfos MGE motor designed to meet EN standards.

The built-in frequency converter enables continuous variable control of the motor speed.

This means that the pump can be set to operation at any duty point. The purpose of continuous variable speed control of the motor speed is to adjust the performance to a given requirement.

E-pumps are available with an integrated pressure sensor connected to the frequency converter that functions as a feedback sensor for constant pressure control.

In new installations, the E-pumps provide a number of advantages. The built-in frequency converter has a built-in motor protection function which protects both motor and electronics against overload.

This means that E-pump installations do not require a motor-protective circuit breaker, but only a normal short-circuit protection for the cable. The pump materials are identical to those of the CR, CRI and CRN pump ranges.

Examples of E-pump applications

E-pumps are the ideal choice for a number of applications characterized by a demand for variable flow at constant pressure. The pumps are suited for water supply systems and pressure boosting as well as for industrial applications.

Depending on the application, the pumps offer energy savings, increased comfort and improved processing.

E-pumps in the industry market

The industry market uses a large number of pumps in many different applications. Demands on pumps in terms of pump performance and mode of operation make speed control a must in many applications.

Some of the applications in which E-pumps are often used are listed below.

Constant pressure

- Water supply
- washing and cleaning systems
- distribution from waterworks
- humidifying systems
- water treatment systems
- process boosting systems.

Example: Within industrial water supply, E-pumps with an integrated pressure sensor are used to ensure a constant pressure in the pipe system. From the feedback sensor, the E-pump receives inputs about changes of pressure as a result of changes in the consumption. The E-pump responds to the input by adjusting the speed until the pressure is equalized. The constant pressure is stabilized once more on the basis of a preset setpoint.

Constant temperature

- Air-conditioning systems at industrial plants
- industrial cooling systems
- industrial freezing systems
- casting and moulding tools.

Example: In industrial freezing systems, E-pumps with a temperature sensor increase the comfort and lower the operating costs compared with pumps without a feedback temperature sensor.

An E-pump continuously adapts its performance to the changing demands reflected in the differences in temperature of the liquid circulating in the freezing system. Thus, the lower the demand for cooling, the smaller the quantity of liquid circulated in the system and vice versa.

Constant level

- Boiler feed systems
- condensate systems
- sprinkler irrigation systems
- chemical industry.

Example: In a steam boiler, it is important to be able to monitor and control the pump operation to maintain a constant level of water in the boiler.

By using an E-pump with a level sensor in the boiler, it is possible to maintain a constant water level.

A constant water level ensures an optimum and cost-efficient operation as a result of a stable steam production.

Dosing applications

- Chemical industry, meaning control of pH values
- petrochemical industry
- paint industry
- degreasing systems
- bleaching systems.

Example: In the petrochemical industry, E-pumps with a pressure sensor are used as dosing pumps.

The E-pumps help to ensure that the correct mixture ratio is achieved when more liquids are combined.

E-pumps functioning as dosing pumps improve processing and offer energy savings.

E-pumps in commercial building market

The commercial building market use E-pumps to maintain a constant pressure or a constant temperature based on a variable flow.

Constant pressure

- Water supply in high-rise buildings, such as office buildings and hotels.

E-pumps with a pressure sensor are used for water supply in high-rise buildings to ensure a constant pressure even at the highest draw-off point. As the consumption pattern and thus the pressure changes during the day, the E-pump continuously adapts its performance until the pressure is equalized.

Constant temperature

- Air-conditioning systems in for example hotels and schools
- building cooling systems.

Example: E-pumps are an excellent choice for buildings where a constant temperature is essential. E-pumps keep the temperature constant in air-conditioned, high-rise glass buildings, irrespective of the seasonal fluctuations of the outdoor temperature and various heat impacts inside the building.

When to select an E-pump

Select an E-pump if the following is required:

- controlled operation, that is the consumption fluctuates
- constant pressure
- communication with the pump.

Adaptation of performance through frequency-controlled speed control offers obvious benefits, such as the following:

- energy savings
- increased comfort
- control and monitoring of the pump performance.

Components of a Grundfos E-pump

An E-pump is not just a pump, but a system which is able to solve application problems or save energy in a variety of pump installations. All that is required is the power supply connection and the fitting of the E-pump in the pipe system, and the pump is ready for operation. The pump has been tested and pre-configured from the factory. The operator only has to specify the desired setpoint (pressure) and the system is operational.

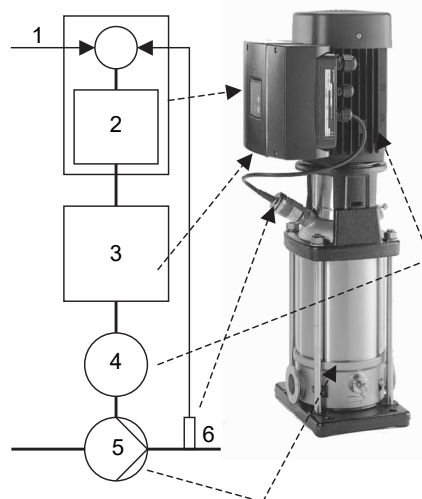

TM030431

Components of a Grundfos E-pump

Pos.	Description
1	Setpoint
2	PI controller
3	Frequency converter
4	Motor
5	Pump
6	Sensor

E-pumps with and without a sensor

CRE, CRIE and CRNE pumps are available with a pressure sensor enabling the control of the pressure on the pump outlet side. The E-pump is also available without a sensor.

The purpose of supplying CRE, CRIE and CRNE pumps with a pressure sensor is to make the installation and startup simple and quick.

Generally, E-pumps without a sensor are used when uncontrolled (open loop) operation is required or when there is a wish to fit a sensor at a later stage to enable the following:

- pressure control
- flow control
- level control of liquid in a tank
- temperature control
- differential pressure control
- differential temperature control.

E-pumps without a sensor are also used when a remote analog signal is connected to the setpoint input terminal. For further information, see the section on control modes.

Related information*Control modes***ErP compliant**

The product is energy-optimized and complies with the ecodesign requirements for water pumps specified in the ErP Directive (Commission Regulation (EC) No 547/2012), which became effective on 1 January 2013. As from this date, all pumps are classified and graduated in the Minimum Efficiency Index (MEI).

Minimum efficiency index

Minimum efficiency index (MEI) means the dimensionless scale unit for hydraulic pump efficiency at best efficiency point (BEP), part load (PL) and overload (OL). The Commission Regulation (EU) sets efficiency requirements to $MEI \geq 0.10$ as from 1 January 2013 and $MEI \geq 0.40$ as from 1 January 2015. An indicative benchmark for best-performing water pump available on the market as from 1 January 2013 is determined in the Commission Regulation.

- The benchmark for most efficient water pumps is $MEI \geq 0.70$.
- The efficiency of a pump with a trimmed impeller is usually lower than that of a pump with the full impeller diameter. The trimming of the impeller will adapt the pump to a fixed duty point, leading to reduced energy consumption. The minimum efficiency index (MEI) is based on the full impeller diameter.
- The operation of this water pump with variable duty points may be more efficient and economic when controlled, for example, by the use of a variable-speed drive that matches the pump duty to the system.
- Information on benchmark efficiency is available at <http://europump.eu/efficiencycharts>.

MEI values for CR pumps

Pump type	MEI
CR 1s-3	0.54
CR 1-3	> 0.70
CR 3-3	> 0.70
CR 5-3	0.57
CR 10-3	> 0.70
CR 15-3	> 0.70
CR 20-3	> 0.70
CR 32-3	> 0.70
CR 45-3	> 0.70
CR 64-3	> 0.70
CR 95-3	> 0.70
CR 125-3	> 0.70
CR 155-3	> 0.70
CR 185-3	> 0.70
CR 215-3	≥ 0.70
CR 255-3	≥ 0.70

2. Applications

Water supply

	CRE	CRIE, CRNE
Filtration and transfer at waterworks	●	○
Distribution from waterworks	●	○
Pressure boosting in mains	●	○
Pressure boosting in, for example, high-rise buildings, hotels	●	○
Pressure boosting for industrial water supply	●	○

Industry

	CRE	CRIE, CRNE
Pressure boosting		
Process-water systems	●	●
Washing and cleaning systems	●	●
Vehicle-washing tunnels	●	○
Firefighting systems	●	-
Liquid transfer		
Cooling and air-conditioning systems (refrigerants)	●	○
Boiler feed and condensate systems	●	○
Machine tools (cooling lubricants)	●	●
Aquafarming	●	○
Special transfer duties		
Oils and alcohols	●	●
Acids and alkalis	-	●
Glycol and coolants	●	●

Water treatment

	CRE	CRIE, CRNE
Ultra-filtration systems	-	●
Reverse osmosis systems	-	●
Softening, ionising, demineralising systems	-	●
Distillation systems	-	●
Separators	●	●
Swimming baths	-	●

Irrigation

	CRE	CRIE, CRNE
Field irrigation (flooding)	●	○
Sprinkler irrigation	●	○
Drip-feed irrigation	●	○

- Recommended version
- Alternative version

Note that for applications involving CIP (clean-in-place) and CR, CRN 95-255 pumps with motors above 55 kW, you must use a bearing flange and a base without thrust handling device.

Related information

[Pumped liquids](#)

3. Features and benefits

Pump

The CR and CRE pumps are non-self-priming, vertical multistage centrifugal pumps.

The pumps are available with a Grundfos frequency-controlled motor.

The pump consists of a pump head and a base.

The chamber stack and the sleeve are secured between the pump head and the base with staybolts. The base has inlet and outlet ports on the same level (in line). All pumps are fitted with a maintenance-free mechanical shaft seal of the cartridge type.

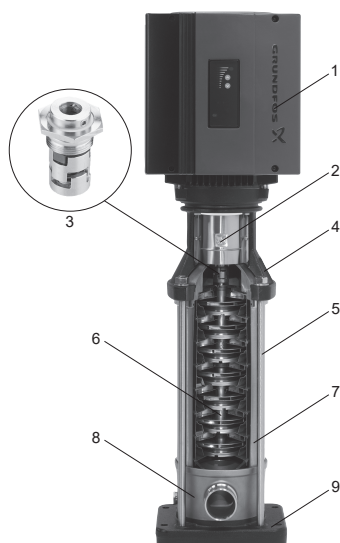

TM1040083

CR pump

Pos.	Description
1	Motor
2	Coupling
3	Shaft seal (cartridge type)
4	Pump head
5	Sleeve
6	Impellers
7	Staybolts
8	Base
9	Base plate

Motor

MGE motors

MGE motors incorporate thermal protection against slow overload and blocking.

CRE, CRIE and CRNE pumps require no external motor protection.

Frequency-controlled MGE motors

CRE, CRIE and CRNE pumps are fitted with a totally enclosed, fan-cooled, frequency-controlled MGE motor with principal dimensions to EN standards.

CRE, CRIE, CRNE pumps from 0.37 to 1.5 kW are available with single-phase MGE motors.

CRE, CRIE, CRNE pumps from 0.37 to 26 kW are available with three-phase MGE motors.

See Grundfos Product Center at www.grundfos.com.

Electrical data

MGE motor	
Mounting designation	Up to 4 kW: V18 5.5 kW and up: V1
Insulation class	F
Efficiency class	0.37 to 26 kW: IE5 level
Enclosure class	0.37 to 26 kW: IP55 (IP66 optional)
Supply voltage	P2: 0.37 - 1.5 kW: 1 x 200-240 V
Tolerance: - 10 %/+ 10 %	P2: 0.37 - 11 kW: 3 x 380-500 V
	P2: 15-26 kW: 3 x 380-480 V
Supply frequency	50/60 Hz

Bluetooth

For MGE motors from 15 to 26 kW, the product incorporates a Bluetooth (BLE) module for remote control. For MGE motors from 0.37 to 11 kW, see the detailed description about Grundfos GO.

Via the built-in Bluetooth module, the product can communicate with Grundfos GO. Bluetooth communication can take place at distances up to 10 metres.

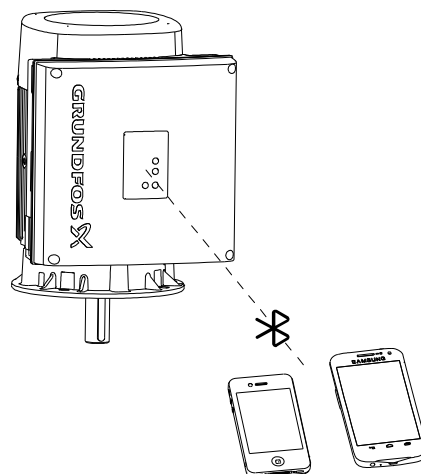

TM082930

Bluetooth information

Frequency of operation	2400 - 2483.5 MHz
Modulation type	GFSK
Data rate	2 Mbps
Transmit power	5 dBm EIRP with internal antenna

GLoWpan information

Frequency of operation	2405-2480 MHz
Modulation type	GP O-QPSK
Data rate	1 Mbps
Transmit power	5 dBm EIRP with internal antenna

Related information

[Grundfos GO](#)

Grundfos GO Link

The product is designed for wired or wireless communication with Grundfos GO Link.

Grundfos GO Link enables you to set functions and gives you access to status overviews, configuration and current operating parameters.

Use Grundfos GO Link together with these interfaces:

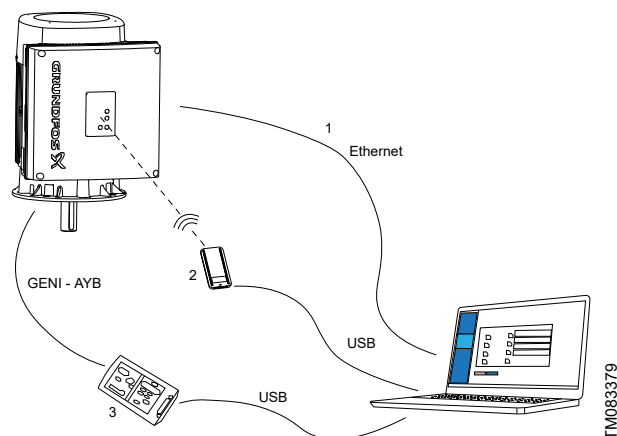

Grundfos GO Link setup

Pos.	Description
1	Ethernet cable: Standard Ethernet cable CAT5/CAT6.
2	Grundfos MI 301: Separate module enabling radio communication. Use the module together with a USB cable to connect to a laptop.
3	Grundfos PC Tool Link: Separate module enabling wired connection to the pump. Use the module together with a USB cable to connect to a laptop.

Functional module, FM 300

MGE 0.37 to 11 kW

The FM 300 is factory-fitted in all pumps from 0.37 to 11 kW.

The module has a number of inputs and outputs enabling the motor to be used in advanced applications where many inputs and outputs are required.

The FM 300 has these connections:

- three analog inputs
- one analog output
- two dedicated digital inputs
- two configurable digital inputs or open-collector outputs
- Grundfos Digital Sensor input and output
- two Pt100/1000 inputs
- two LiqTec sensor inputs
- two signal relay outputs
- GENIbus connection.

Connection terminals

All inputs and outputs are internally separated from the mains-conducting parts by reinforced insulation and galvanically separated from other circuits. All control terminals are supplied with protective extra-low voltage (PELV), thus ensuring protection against electric shock.

- Signal relay outputs
 - Signal relay 1:
 - LIVE:

Power supply voltages up to 250 VAC can be connected to this output.
 - PELV:

The output is galvanically separated from other circuits. Therefore, the supply voltage or protective extra-low voltage can be connected to the output as desired.
 - Signal relay 2:
 - PELV:

The output is galvanically separated from other circuits. Therefore, the supply voltage or protective extra-low voltage can be connected to the output as desired.
- **Power supply** (terminals N, PE, L or L1, L2, L3, PE)

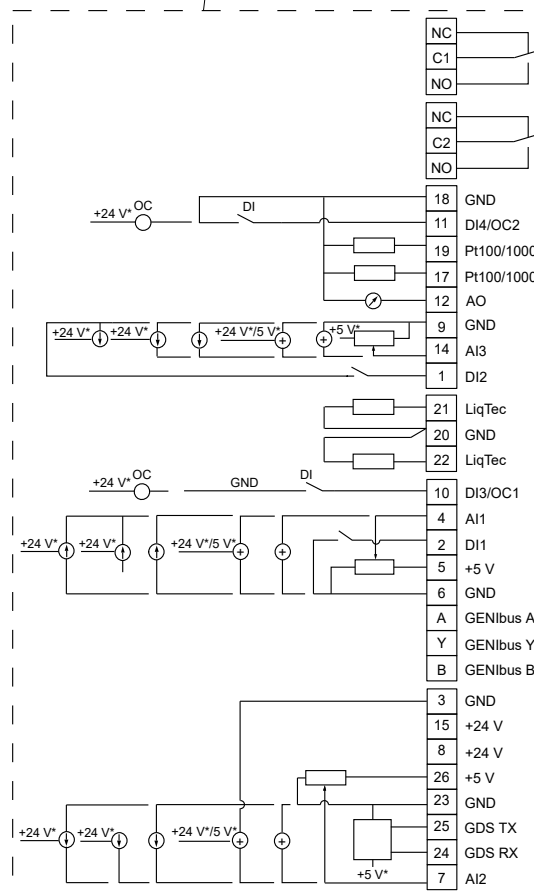
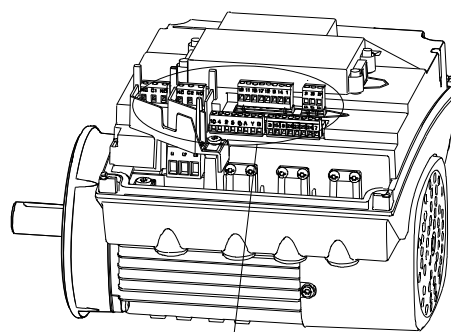

TM053509

* If an external supply source is used, there must be a connection to GND.

Connection terminals, FM 300 functional module

Functional module, FM 310 and FM 311

MGE 15 to 26 kW

FM 310 and FM 311 are factory-fitted in all pumps from 15 to 26 kW.

Inputs and outputs

Note that the FM 311 functional module does not include Bluetooth connection.

The module has these connections:

- three analog inputs
- one analog output
- two dedicated digital inputs
- two configurable digital inputs or open-collector outputs
- Grundfos Digital Sensor input and output
- two Pt100/1000 inputs
- two LiqTec sensor inputs
- two signal relay outputs
- GENIbus/Modbus connection
- two Safe Torque Off (STO) inputs¹⁾
- Ethernet connection
- Bluetooth (BLE) connection.²⁾

¹⁾ Safe Torque Off (STO) is a safety function with the purpose to stop the motor from turning, without actively braking it. It follows the definition by EN 61800-5-2.

²⁾ FM 311 is without Bluetooth.

Connection terminals

All control terminals are supplied with safety extra-low voltage (SELV), ensuring protection against electric shock.

The inputs and outputs are internally separated from the mains-conducting parts by reinforced insulation and galvanically separated from other circuits.

Cables for the relays and the Ethernet cable must be rated at least 250V/2A.

The relays are approved for overvoltage category II, whether power is supplied from a transformer or the power supply.

Signal relay outputs

Signal relay 1

LIVE: You can connect supply voltages up to 250 VAC to the output.

SELV: The output is galvanically separated from other circuits. Therefore, you can connect the supply voltage or safety extra-low voltage to the output as desired.

Signal relay 2

SELV: The output is galvanically separated from other circuits. Therefore, you can connect the supply voltage or safety extra-low voltage to the output as desired.

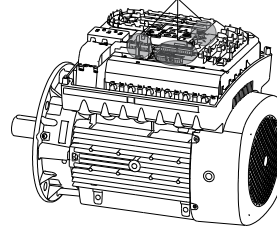
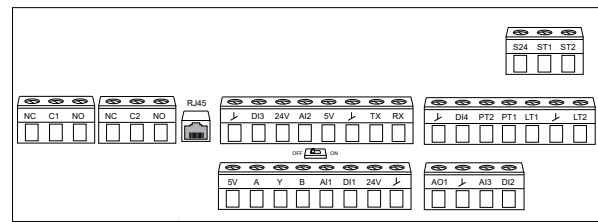

TM082862

Terminal	Type	Function
NC	Normally closed contact	
C1	Common	Signal relay 1: LIVE or SELV
NO	Normally open contact	
NC	Normally closed contact	
C2	Common	Signal relay 2: SELV only
NO	Normally open contact	
RJ45	Ethernet	Ethernet communication
GND	GND	Signal ground
DI3	DI3/OC1	Digital input/output, configurable Open collector: Maximum 24 V resistive or inductive
24V	+24 V	Power supply
AI2	AI2	Analog input: • 0-20 mA or 4-20 mA • 0.5 - 3.5 V, 0-5 V or 0-10 V.
5V	+5 V	Power supply to a potentiometer or sensor
GND	GND	Signal ground
TX	GDS TX	Grundfos Digital Sensor output
RX	GDS RX	Grundfos Digital Sensor input
GND	GND	Signal ground
DI4	DI4/OC2	Digital input/output, configurable Open collector: Maximum 24 V resistive or inductive
PT2	Pt100/1000 input 2	Pt100/1000 sensor input 2
PT1	Pt100/1000 input 1	Pt100/1000 sensor input 1
LT1	LiqTec sensor input 1	LiqTec sensor input 1 White conductor
GND	GND	Signal ground Brown and black conductors
LT2	LiqTec sensor input 2	LiqTec sensor input 2 Blue conductor
5V	+5 V	Power supply to a potentiometer or sensor
A	GENIbus, A	GENIbus, A (+) / Modbus, D1 (+)
Y	GENIbus, Y	GENIbus, GND / Modbus, GND
B	GENIbus, B	GENIbus, B (-) / Modbus, D0 (-)
AI1	AI1	Analog input: • 0-20 mA or 4-20 mA • 0.5 - 3.5 V, 0-5 V or 0-10 V.

Terminal	Type	Function
D11	D11	Digital input ³⁾ , configurable
24V	+24 V	Power supply
GND	GND	Signal ground
AO1	AO	Analog output: • 0-20 mA or 4-20 mA • 0-10 V.
GND	GND	Signal ground
AI3	AI3	Analog input: • 0-20 mA or 4-20 mA • 0.5 - 3.5 V, 0-5 V or 0-10 V.
DI2	DI2	Digital input, configurable
S24	+24 V (STO)	Power supply to the Safe Torque Off inputs
ST1	STO1	Safe Torque Off - Input 1
ST2	STO2	Safe Torque Off - Input 2

³⁾ Digital input 1 is factory-set to be start or stop input where an open circuit results in stop. A jumper has been factory-fitted between terminals D11 and GND. Remove the jumper if digital input 1 is to be used as external start or stop or any other external function.

Terminal box positions

As standard, the terminal box is fitted on the inlet side of the pump.

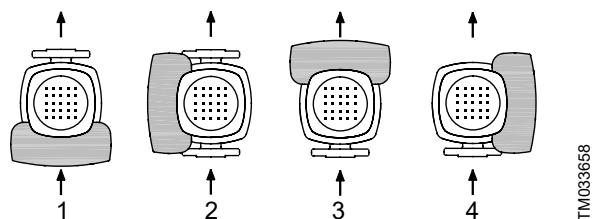

TM033658

Terminal box positions

Pos.	Description
1	6 o'clock position (standard)
2	9 o'clock position
3	12 o'clock position
4	3 o'clock position

Ambient temperature and installation altitude

The ambient temperature and the installation altitude are important factors for the motor life, as they affect the bearings and the insulation system. The installation altitude is the height of the installation site above sea level.

Motors installed at maximum ambient temperature and altitude can be loaded 100 %.

If the ambient temperature or the installation altitude exceeds the recommended maximum values, the motor must not be fully loaded due to the risk of overheating. Overheating may result from excessive ambient temperatures or high altitudes with low density and low cooling effect of the air.

In such cases, it may be necessary to select an oversized motor with a higher rated output. To determine the motor load, it is necessary to calculate the derated motor power.

Maximum ambient temperature and altitude for Grundfos MGE motors

The table shows the maximum permissible ambient temperature at full load and the maximum permissible installation altitude above sea level at full load.

Motor efficiency class: IE5

Motor power [kW]	Motor make	Phase	Max. ambient temperature [°C]	Max. altitude [m]
0.37 - 1.5	MGE	1	50	1000
0.37 - 11	MGE	3	50 ⁴⁾	1000
15-22	MGE	3	50	1000
26	MGE	3	40	1000

4) 3 x 200–240 V MGE motors are rated for a maximum ambient temperature of 40 °C.

Motor load for Grundfos MGE motors

MGE motors can be installed up to 3500 metres above sea level.

Motors installed above the maximum installation altitude of 1000 metres above sea level must not be fully loaded. Use the below diagram to calculate the derated motor power. If the required motor output exceeds the derated motor power, select an oversized motor.

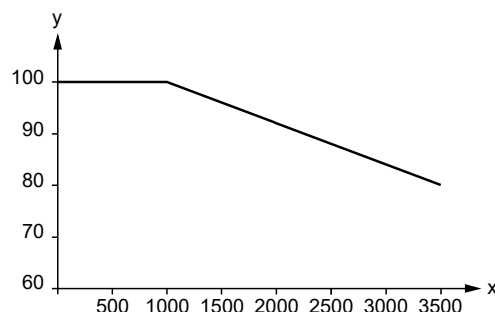

TM085266

Derating of motor output power P_2 % (y-axis) in relation to installation altitude above sea level in metres (x-axis)

4. Performance range

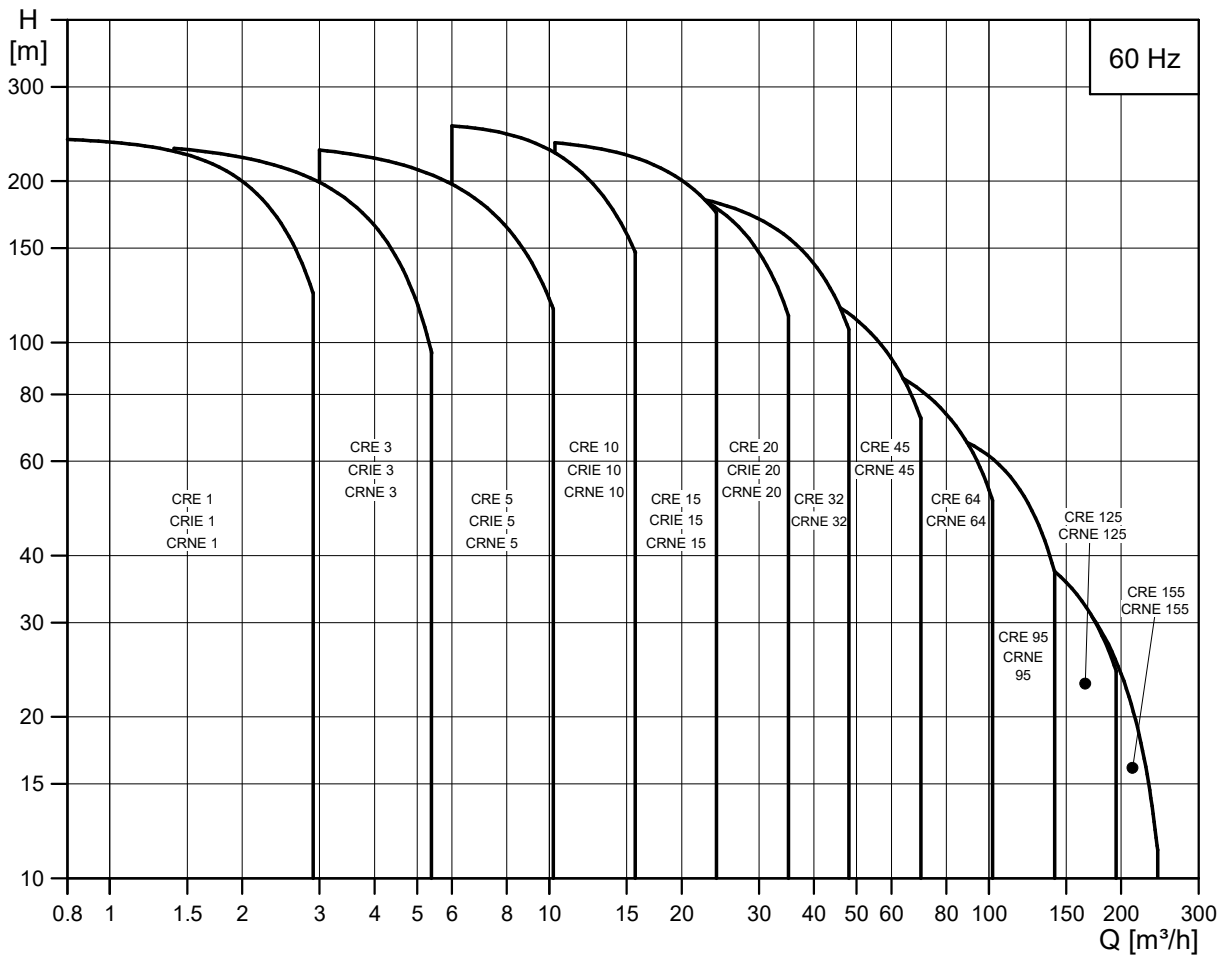

TM027357

Performance range, CRE, CRIE and CRNE

5. Product range

CRE, CRIE, CRNE pump size	1	3	5	10	15	20
Rated flow rate [m ³ /h]	1.2	3.6	6	12	18	24
Flow rate [m ³ /h]	0.8 - 2.9	1.4 - 5.4	3 - 10.2	6-16	10-29	13-35
Minimum liquid temperature [°C] ⁵⁾	-20	-20	-20	-20	-20	-20
Maximum liquid temperature [°C] ⁵⁾	+120	+120	+120	+120	+120	+120
Maximum pump efficiency [%]	49	59	67	70	72	72
Maximum pressure [bar]	24	24	23	26	24	21
Motor power [kW]	0.37 - 3.0	0.37 - 4.0	0.55 - 7.5	0.75 - 11	1.5 - 18.5	2.2 - 18.5
Standard versions						
CRE:						
Cast iron and stainless steel	•	•	•	•	•	•
EN 10088 1.4301≈AISI 304						
CRIE:						
Stainless steel	•	•	•	•	•	•
EN 10088 1.4301≈AISI 304						
CRNE:						
Stainless steel	•	•	•	•	•	•
EN 10088 1.4401≈AISI 316						
CRE pipe connection						
Oval flange (BSP)	Rp 1	Rp 1	Rp 1 1/4	Rp 1 1/2	Rp 2	Rp 2
Oval flange (BSP), on request	Rp 1 1/4	Rp 1 1/4	Rp 1	Rp 1 1/4 Rp 2	Rp 2 1/2	Rp 2 1/2
Flange	DN 25/ DN 32	DN 25/ DN 32	DN 25/ DN 32	DN 40	DN 50	DN 50
Flange, on request	-	-	-	DN 50	-	-
CRIE pipe connection						
Oval flange (BSP)	Rp 1	Rp 1 1/4	Rp 1 1/4	Rp 1 1/2	Rp 2	Rp 2
Oval flange (BSP), on request	Rp 1 1/4	Rp 1	Rp 1	Rp 2	-	-
Flange	DN 25/ DN 32	DN 25/ DN 32	DN 25/ DN 32	DN 40	DN 50	DN 50
Flange, on request	-	-	-	DN 50	-	-
PJE coupling (Victaulic)	DN 32	DN 32	DN 32	DN 50	DN 50	DN 50
Actual outside diameter [mm]	∅48.3	∅48.3	∅48.3	∅60.3	∅60.3	∅60.3
Union (+GF+)	G 2	G 2	G 2	G 2 3/4	G 2 3/4	G 2 3/4
CRNE pipe connection						
Oval flange (BSP)	Rp 1	Rp 1 1/4	Rp 1 1/4	Rp 1 1/2	Rp 2	Rp 2
Oval flange (BSP), on request	Rp 1 1/4	Rp 1	Rp 1	Rp 2	-	-
Flange	DN 25/ DN 32	DN 25/ DN 32	DN 25/ DN 32	DN 40	DN 50	DN 50
Flange, on request	-	-	-	DN 50	-	-
PJE coupling (Victaulic)	DN 32	DN 32	DN 32	DN 50	DN 50	DN 50
Actual outside diameter [mm]	∅42.5	∅42.5	∅42.5	∅60.3	∅60.3	∅60.3
Union (+GF+)	G 2	G 2	G 2	G 2 3/4	G 2 3/4	G 2 3/4

⁵⁾ Liquid temperature -40 to +180 °C (oils up to +240 °C) is available on request.

• Standard.

CRE, CRNE pump size	32	45	64	95	125	155
Rated flow rate [m ³ /h]	38	54	77	115	150	185
Flow rate [m ³ /h]	18-48	26-70	36-102	58-150	75-195	90-240
Minimum liquid temperature [°C] ⁶⁾⁷⁾	-30	-30	-30	-30	-30	-30
Maximum liquid temperature [°C] ⁶⁾⁷⁾	+120	+120	+120	+120	+120	+120
Maximum pump efficiency [%]	76	78	79	81	78	78
Maximum pressure [bar]	27	26	18.2	8	8	4
Motor power [kW]	2.2 - 22	5.5 - 22	7.5 - 22	11-22	15-22	18.5
Standard versions						
CRE:						
Cast iron and stainless steel	•	•	•	•	•	•
EN 10088 1.4301≈AISI 304						
CRNE:						
Stainless steel	•	•	•	•	•	•
EN 10088 1.4401≈AISI 316						
CRE pipe connection						
Oval flange (BSP)	-	-	-	-	-	-
Oval flange (BSP), on request	-	-	-	-	-	-
Flange	DN 65	DN 80	DN 100	DN 100	DN 150	DN 150
Flange, on request	DN 80	DN 100	DN 125	DN 125	-	-
CRNE pipe connection						
Oval flange (BSP)	-	-	-	-	-	-
Oval flange (BSP), on request	-	-	-	-	-	-
Flange	DN 65	DN 80	DN 100	DN 100	DN 150	DN 150
Flange, on request	DN 80	DN 100	DN 125	DN 125	-	-
PJE coupling (Victaulic)	DN 80	DN 100	DN 100	DN 100	DN 150	DN 150
Actual outside diameter [mm]	88.9	114.3	114.3	114.3	168.3	168.3
Union (+GF+)	-	-	-	-	-	-

6) The liquid temperature range for CRNE 32 to 155 with HQQE shaft seal is -40 to +120 °C.

7) CRE, CRNE 32-95: Liquid temperature -40 to +180 °C (oils up to +240 °C) is available on request.

• Standard.

6. Identification

Type key

Example: CRE 32-3-2 A-F-A-E-HQQE

Code	Explanation
CR	Type range: CR, CRI, CRN, CRT
E	Pump with integrated frequency converter
32	Flow rate [m ³ /h]
3	Number of impellers
2	Number of reduced-diameter impellers
A	Code for pump version
F	Code for pipe connection
A	Code for materials
E	Code for rubber parts
	Code for shaft seal:
H	Shaft seal type designation
Q	Seal face material (rotating seal face)
Q	Seal face material (stationary seal face)
E	Secondary seal material (rubber parts)

Key to codes

Code	Description
Pump version	
A	Basic version
B	Oversize motor
C	CR compact
D	Pump with pressure intensifier
E	Pump with certificate
F	Pump for high temperatures (with air-cooled top)
G	E-pump without operating panel
H	Horizontal version
I	Different pressure rating
J	E-pump with a different maximum speed
K	Pump with low NPSH
L	Pump including Grundfos CUE and certificate
M	Magnetic drive
N	With sensor
O	Cleaned and dried
P	Undersize motor
Q	High-pressure pump with high-speed MGE motor
R	Belt-driven pump
S	High-pressure pump
T	Thrust-handling device
U	ATEX-approved pump
V	Cascade function
W	Deep-well pump with ejector
X	Special version
Y	Electropolished
Z	Pumps with bearing flange
Pipe connection	
A	Oval flange
B	NPT thread
CA	FlexiClamp

Code	Description
CX	TriClamp
F	DIN flange
FC	DIN 11853-2 flange (collar flange)
FE	EN 1092-1, type E
G	ANSI flange
J	JIS flange
N	Changed diameter of ports
P	PJE coupling (Victaulic type)
X	Special version

Materials	
A	Basic version
C	Carbon-free pump
D	Carbon-graphite-filled PTFE (bearings)/tungsten carbide
E	Pickled and passivated (Only Japan)
H	Flanges and base plate EN 1.4408
K	Bronze (bearings)/tungsten carbide
L	Motor stool, base plate and flanges EN 1.4408
M	Motor stool, base plate, coupling and flanges EN 1.4408 and coupling guards in cobber. Bolts, nuts and spacing pipes EN 1.4401 or higher grade
N	Flanges EN 1.4408
P	PEEK neck ring
Q	Silicon carbide/silicon carbide bearing in pump and silicon carbide/silicon carbide seal faces in thrust-handling device
R	Silicon carbide/silicon carbide bearing
S	PTFE neck rings
T	Base plate EN 1.4408
U	Silicon carbide/silicon carbide bearing in pump and silicon carbide/tungsten carbide seal faces in thrust-handling device
W	Tungsten carbide/tungsten carbide
X	Special version

Rubber parts in pump	
E	EPDM
F	FXM (Fluoraz [®])
K	FFKM (Kalrez [®])
N	CR (Neoprene)
V	FKM (Viton [®])

Shaft seal type designation	
A	O-ring seal with fixed driver
H	Balanced cartridge seal with O-ring
O	Double seal, back-to-back
P	Double seal, tandem
X	Special version

Seal face material (rotating and stationary seal face)	
B	Carbon, synthetic resin-impregnated
U	Cemented tungsten carbide
Q	Silicon carbide
X	Other ceramics

Secondary seal material (rubber parts)	
--	--

Code	Description
E	EPDM
F	FXM (Fluoraz®)
K	FFKM (Kalrez®)
V	FKM (Viton®)

7. Construction

CRE 1, 3, 5, 10, 15, 20

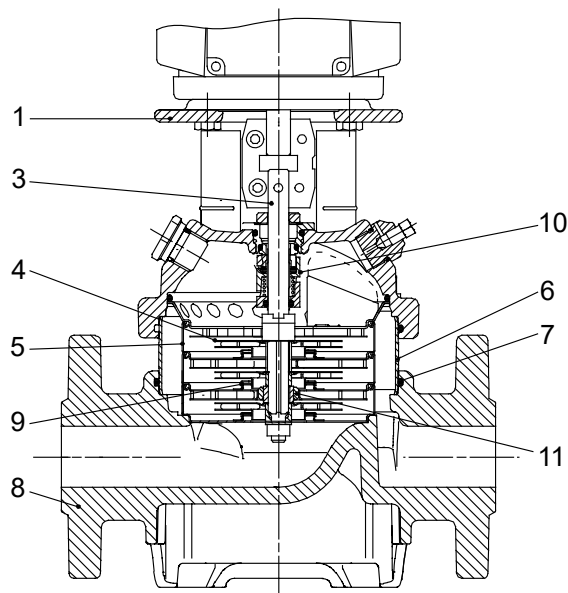

TM021194

Materials, CRE

Pos.	Designation	Materials	DIN/EN	≈ AISI/ASTM
1	Pump head	Grey cast iron	EN 1561 EN-GJL-200	ASTM 25B
3	Shaft	Stainless steel	EN 10088 1.4401 ⁸⁾ EN 10088 1.4057 ⁹⁾	AISI 316 ⁸⁾ AISI 431 ⁹⁾
4	Impeller	Stainless steel	EN 10088 1.4301	AISI 304
5	Chamber	Stainless steel	EN 10088 1.4301	AISI 304
6	Sleeve	Stainless steel	EN 10088 1.4301	AISI 304
7	O-ring for sleeve	EPDM or FKM	-	-
8	Base	Grey cast iron	EN 1561 EN-GJL-250	ASTM 25B
9	Neck ring	PTFE	-	-
10	Shaft seal (seal faces)	Silicon carbide/silicon carbide	-	-
11	Bearing ring	Silicon carbide/silicon carbide	-	-
	Staybolts	Bright steel	EN 10277 C35R	-

⁸⁾ CRE 1, 3, 5.

⁹⁾ CRE 10, 15, 20.

CRIE 1, 3, 5, 10, 15, 20

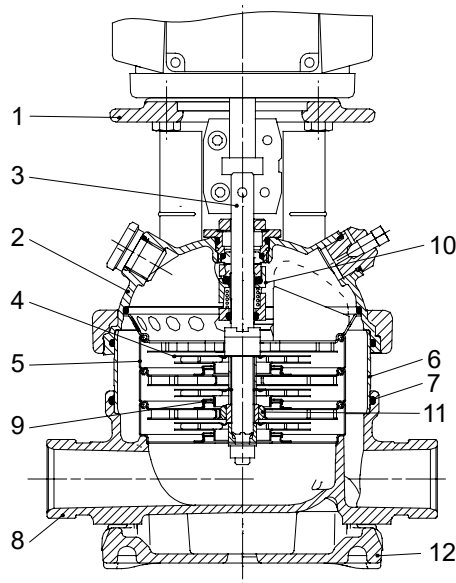

TM021195

Materials, CRIE

Pos.	Designation	Materials	DIN/EN	≈ AISI/ASTM
1	Motor stool	Grey cast iron ¹⁰⁾	EN 1563 EN-GJS-450-10	ASTM A536 65-45-12
2	Pump head	Stainless steel	EN 10283 1.4408	CF 8M equal to AISI 316
3	Shaft	Stainless steel	EN 10088 1.4401 ¹¹⁾ EN 10088 1.4057 ¹²⁾	AISI 316 ¹¹⁾ AISI 431 ¹²⁾
4	Impeller	Stainless steel	EN 10088 1.4301	AISI 304
5	Chamber	Stainless steel	EN 10088 1.4301	AISI 304
6	Sleeve	Stainless steel	EN 10088 1.4301	AISI 304
7	O-ring for sleeve	EPDM or FKM	-	-
8	Base	Stainless steel	EN 10283 1.4408	CF 8M equal to AISI 316
9	Neck ring	PTFE	-	-
10	Shaft seal (seal faces)	Silicon carbide/silicon carbide	-	-
11	Bearing ring	Silicon carbide/silicon carbide	-	-
12	Base plate	Grey cast iron ¹⁰⁾	EN 1561 EN-GJL-200 ^{12)+ 13)} EN 1563 EN-GJS-500-7 ¹⁴⁾	ASTM 25B ^{12)+ 13)} ASTM A536 65-45-12 ¹⁴⁾
	Staybolts	Bright steel	EN 10277 C35R	-

¹⁰⁾ Stainless steel available on request.

¹¹⁾ CRIE 1, 3, 5.

¹²⁾ CRIE 10, 15, 20.

¹³⁾ CRIE 1, 3, 5 with FGJ flange connection.

¹⁴⁾ CRIE 1, 3, 5 with clamp connections, such as PJE, CA.

CRNE 1, 3, 5, 10, 15, 20

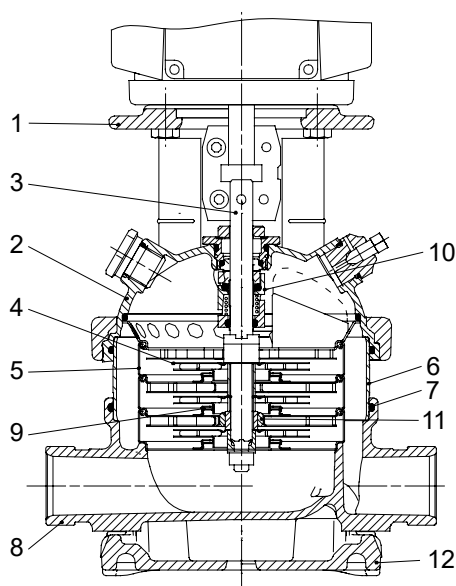

TM021195

Materials, CRNE

Pos.	Designation	Materials	DIN/EN	≈ AISI/ASTM
1	Motor stool	Grey cast iron ¹⁵⁾	EN 1563 EN-GJS-450-10	ASTM A536 65-45-12
2	Pump head	Stainless steel	EN 10283 1.4408	CF 8M equal to AISI 316
3	Shaft	Stainless steel	EN 10088 1.4401 ¹⁶⁾ EN 10088 1.4460 ¹⁷⁾	AISI 316 ¹⁶⁾ AISI 329 ¹⁷⁾
4	Impeller	Stainless steel	EN 10088 1.4401	AISI 316
5	Chamber	Stainless steel	EN 10088 1.4401	AISI 316
6	Sleeve	Stainless steel	EN 10088 1.4401	AISI 316
7	O-ring for sleeve	EPDM or FKM	-	-
8	Base	Stainless steel	EN 10283 1.4408	CF 8M equal to AISI 316
9	Neck ring	PTFE	-	-
10	Shaft seal (seal faces)	Silicon carbide/silicon carbide	-	-
11	Bearing ring	Silicon carbide/silicon carbide	-	-
12	Base plate	Grey cast iron ¹⁵⁾	EN 1561 EN-GJL-200 ^{17)+ 18)} EN 1563 EN-GJS-500-7 ¹⁹⁾	ASTM 25B ^{17)+ 18)} ASTM A536 65-45-12 ¹⁹⁾
	Staybolts	Stainless steel	EN 10088 1.4401 ¹⁶⁾ EN 10088 1.4057 ¹⁷⁾	AISI 316 ¹⁶⁾ AISI 431 ¹⁷⁾

¹⁵⁾ Stainless steel available on request.

¹⁶⁾ CRNE 1, 3, 5.

¹⁷⁾ CRNE 10, 15, 20.

¹⁸⁾ CRNE 1, 3, 5 with FGJ flange connection.

¹⁹⁾ CRNE 1, 3, 5 with clamp connections, such as PJE, CA.

CRE 32, 45, 64

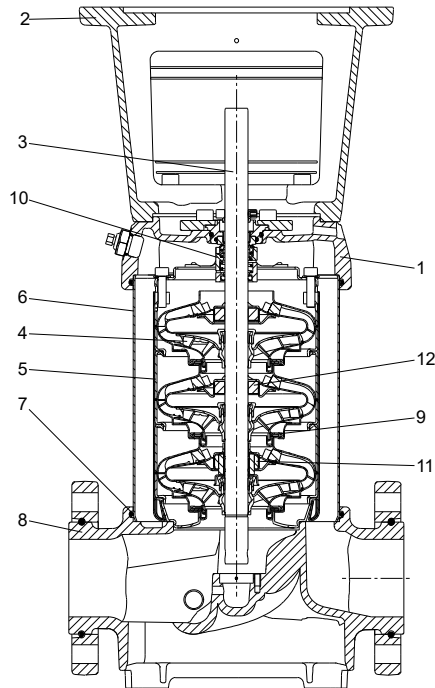

TM060711

Materials, CRE

Pos.	Designation	Materials	DIN/EN	≈ AISI/ASTM
1	Pump head	Ductile cast iron	EN 1563 EN-GJS-500-7	ASTM A536 65-45-12
2	Motor stool	Grey cast iron	EN 1561 EN-GJL-200	ASTM 25B
3	Shaft	Stainless steel	EN 10088 1.4057	AISI 431
4	Impeller	Stainless steel	EN 10088 1.4301	AISI 304
5	Chamber	Stainless steel	EN 10088 1.4301	AISI 304
6	Sleeve	Stainless steel	EN 10088 1.4301	AISI 304
7	O-ring for sleeve	EPDM or FKM	-	-
8	Base	Ductile cast iron	EN 1563 EN-GJS-500-7	ASTM A536 65-45-12
9	Neck ring	Carbon-graphite-filled PTFE	-	-
10	Shaft seal (seal faces)	Silicon carbide/silicon carbide	-	-
11	Bearing ring	Silicon carbide/silicon carbide	-	-
12	Support bushing	Carbon-graphite-filled PTFE	-	-
13	Base plate	Ductile cast iron	EN 1563 EN-GJS-500-7	ASTM A536 65-45-12
	Staybolts	Bright steel	EN 10277 ETG 35	-

CRNE 32, 45, 64

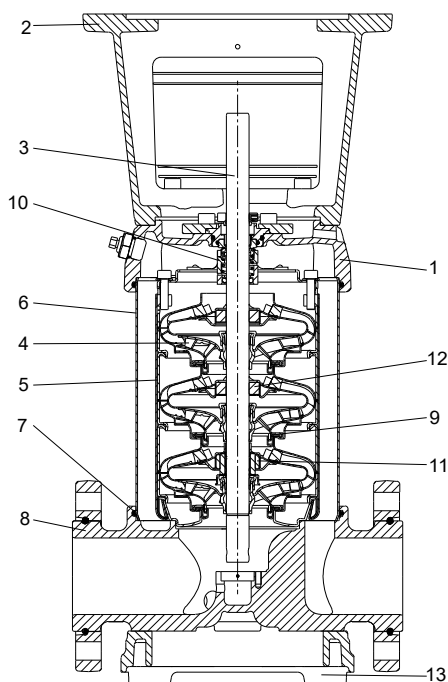

TM060712

Materials, CRNE

Pos.	Designation	Materials	DIN/EN	≈ AISI/ASTM
1	Pump head	Stainless steel	EN 10283 1.4408	CF 8M equal to AISI 316
2	Motor stool	Grey cast iron ²⁰⁾	EN 1561 EN-GJL-200	ASTM 25B
3	Shaft	Stainless steel	EN 10088 1.4462	-
4	Impeller	Stainless steel	EN 10088 1.4401	AISI 316
5	Chamber	Stainless steel	EN 10088 1.4401	AISI 316
6	Sleeve	Stainless steel	EN 10088 1.4401	AISI 316
7	O-ring for sleeve	EPDM or FKM	-	-
8	Base	Stainless steel	EN 10283 1.4408	CF 8M equal to AISI 316
9	Neck ring	Carbon-graphite-filled PTFE	-	-
10	Shaft seal (seal faces)	Silicon carbide/silicon carbide	-	-
11	Bearing ring	Silicon carbide/silicon carbide	-	-
12	Support bushing	Carbon-graphite-filled PTFE	-	-
13	Base plate	Ductile cast iron ²⁰⁾	EN 1563 EN-GJS-500-7	ASTM A536 65-45-12
	Staybolts	Stainless steel	EN 10088 1.4057	AISI 431

²⁰⁾ Stainless steel available on request.

CRE 95, 125, 155

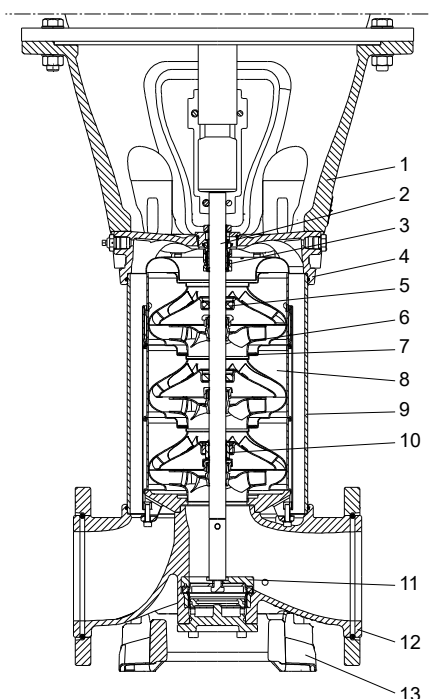

TM065161

Materials, CRE

Pos.	Designation	Materials	DIN/EN	≈ AISI/ASTM
1	Motor stool	Ductile cast iron	EN 1563 EN-GJS-500-7	ASTM A536-84 65-45-12
2	Shaft	Stainless steel	EN 10088 1.4057 ²¹⁾ EN 10088 1.4462 ²²⁾	AISI 431 ²¹⁾ AISI 318 LN ²²⁾
3	Shaft seal (seal faces)	Silicon carbide/silicon carbide	-	-
4	Pump head	Ductile cast iron	EN 1563 EN-GJS-500-7	ASTM A536-84 65-45-12
5	Support bearing (bush)	Carbon-graphite-filled PTFE		
6	Impeller	Stainless steel	EN 10088 1.4301 EN 10088 1.4401	AISI 304 AISI 316
7	Neck ring	PEEK	-	-
8	Chamber	Stainless steel	EN 10088 1.4301 EN 10088 1.4401	AISI 304 AISI 316
9	Sleeve	Stainless steel	EN 10088 1.4301 ²¹⁾ EN 10088 1.4404 ²²⁾	AISI 304 ²¹⁾ AISI 316 L ²²⁾
10	Bearing ring	Tungsten carbide/tungsten carbide	-	-
11	Thrust handling device ²³⁾	Stainless steel	EN 10088 1.4401 EN 10283 1.4408	AISI 316 CF 8M equal to AISI 316
		Silicon carbide/tungsten carbide	-	-
12	Base	Ductile cast iron	EN 1563 EN-GJS-500-7	ASTM A536-84 65-45-12
13	Base plate	Ductile cast iron	EN 1563 EN-GJS-500-7	ASTM A536-84 65-45-12
	Staybolts	Stainless steel	EN 10088 1.4057	AISI 431

²¹⁾ CRE 95.

²²⁾ CRE 125, 155.

²³⁾ Only fitted on pumps with 75 kW motors or larger.

CRNE 95, 125, 155

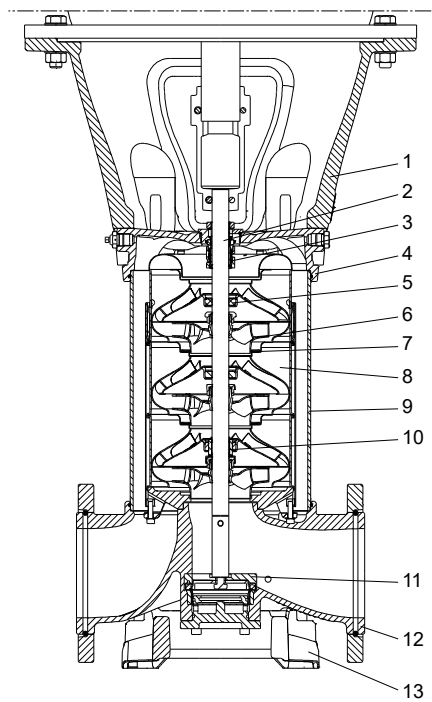

TM065161

Materials, CRNE

Pos.	Designation	Materials	DIN/EN	≈ AISI/ASTM
1	Motor stool	Ductile cast iron	EN 1563 EN-GJS-500-7	ASTM A536-84 65-45-12
2	Shaft	Stainless steel	EN 10088 1.4462	318 LN
3	Shaft seal (seal faces)	Silicon carbide/silicon carbide	-	-
4	Pump head	Stainless steel	EN 10283 1.4408	CF 8M
5	Support bearing (bush)	Carbon-graphite-filled PTFE	-	-
6	Impeller	Stainless steel	EN 10088 1.4401	AISI 316
7	Neck ring	PEEK	-	-
8	Chamber	Stainless steel	EN 10088 1.4401	AISI 316
9	Sleeve	Stainless steel	EN 10088 1.4404	AISI 316 L
10	Bearing ring	Tungsten carbide/tungsten carbide	-	-
11	Thrust handling device ²⁴⁾	Stainless steel	EN 10088 1.4401	AISI 316
		Silicon carbide/tungsten carbide	-	-
12	Base	Stainless steel	EN 10283 1.4408	CF 8M
13	Base plate	Ductile cast iron	EN 1563 EN-GJS-500-7	ASTM A536-84 65-45-12
	Staybolts	Stainless steel	EN 10088 1.4057	AISI 431

²⁴⁾ Only fitted on pumps with 75 kW motors or larger.

8. Operating conditions

Pumped liquids

The pumps are designed to pump non-explosive liquids that do not chemically attack the pump materials.

When pumping liquids with a density and/or viscosity higher than that of water, oversized motors may be required.

Whether a pump is suitable for a particular liquid depends on several factors of which the most important are the chloride content, pH-value, temperature and content of chemicals and oils.

Please note that aggressive liquids may attack or dissolve the protective oxide film of the stainless steel and thus cause corrosion.

CRE and CRIE

The pumps are suitable for non-corrosive liquids.

Use them for liquid transfer, circulation and pressure boosting of cold or hot clean water.

CRNE

The pumps are suitable for industrial liquids.

Use them in systems where all parts in contact with the liquid must be made of high-grade stainless steel.

List of pumped liquids

A number of typical liquids are listed below.

Other pump versions may be applicable, but those stated in the list are considered to be the best choices.

The table is intended as a general guide only and cannot replace actual testing of the pumped liquids and pump materials under specific working conditions.

Therefore, use the list with some caution. Factors such as those mentioned below may affect the chemical resistance of a specific pump version:

- concentration of the pumped liquid
- liquid temperature
- pressure.

Take safety precautions when pumping dangerous liquids.

Notes

D	Often with additives.
E	The density and/or viscosity differ from that/those of water. Take this factor into account when calculating motor output and pump performance.
F	Pump selection depends on many factors. Contact Grundfos.
H	Risk of crystallisation/precipitation in shaft seal.
1	Highly flammable liquid.
2	Combustible liquid.
3	Insoluble in water.
4	Low self-ignition point.

Pumped liquid	Chemical formula	Note	Liquid concentration, liquid temperature	CRE	CRNE
Acetic acid	CH ₃ COOH	-	5 %, 20 °C	-	HQQE
Acetone	CH ₃ COCH ₃	1, F	100 %, 20 °C	-	HQQE
Alkaline degreasing agent		D, F	-	HQQE	-
Ammonium bicarbonate	NH ₄ HCO ₃	E	20 %, 30 °C	-	HQQE
Ammonium hydroxide	NH ₄ OH	-	20 %, 40 °C	HQQE	-
Aviation fuel		1, 3, 4, F	100 %, 20 °C	HQBV	-
Benzoic acid	C ₆ H ₅ COOH	H	0.5 %, 20 °C	-	HQQV
Boiler water		-	< 120 °C	HQQE	-
		F	120-180 °C	-	-
Calcareous water		-	< 90 °C	HQQE	-
Calcium acetate (as coolant with inhibitor)	Ca(CH ₃ COO) ₂	D, E	30 %, 50 °C	HQQE	-
Calcium hydroxide	Ca (OH) ₂	E	Saturated solution, 50 °C	HQQE	-
Chloride-containing water		F	< 30 °C, maximum 500 ppm	-	HQQE
Chromic acid	H ₂ CrO ₄	H	1 %, 20 °C	-	HQQV
Citric acid	HOC(CH ₂ CO ₂ H) ₂ COOH	H	5 %, 40 °C	-	HQQE
Completely desalinated water (demineralised water)		-	120 °C	-	HQQE
Condensate		-	120 °C	HQQE	-
Copper sulphate	CuSO ₄	E	10 %, 50 °C	-	HQQE
Corn oil		D, E, 3	100 %, 80 °C	HQQV	-
Diesel oil		2, 3, 4, F	100 %, 20 °C	HQBV	-
Domestic hot water (potable water)		-	< 120 °C	HQQE	-
Ethanol (ethyl alcohol)	C ₂ H ₅ OH	1, F	100 %, 20 °C	HQQE	-
Ethylene glycol	HOCH ₂ CH ₂ OH	D, E	50 %, 50 °C	HQQE	-
Formic acid	HCOOH	-	5 %, 20 °C	-	HQQE
Glycerine (glycerol)	OHCH ₂ CH(OH)CH ₂ OH	D, E	50 %, 50 °C	HQQE	-
Hydraulic oil (mineral)		E, 2, 3	100 %, 100 °C	HQQV	-
Hydraulic oil (synthetic)		E, 2, 3	100 %, 100 °C	HQQV	-
Isopropyl alcohol	CH ₃ CHOHCH ₃	1, F	100 %, 20 °C	HQQE	-
Lactic acid	CH ₃ CH(OH)COOH	E, H	10 %, 20 °C	-	HQQV
Linoleic acid	C ₁₇ H ₃₁ COOH	E, 3	100 %, 20 °C	HQQV	-
Methanol (methyl alcohol)	CH ₃ OH	1, F	100 %, 20 °C	HQQE	-
Motor oil		E, 2, 3	100 %, 80 °C	HQQV	-
Naphthalene	C ₁₀ H ₈	E, H	100 %, 80 °C	HQQV	-
Nitric acid	HNO ₃	F	1 %, 20 °C	-	HQQE
Oil-containing water		-	< 100 °C	HQQV	-
Olive oil		D, E, 3	100 %, 80 °C	HQQV	-
Oxalic acid	(COOH) ₂	H	1 %, 20 °C	-	HQQE
Ozone-containing water	(O ₃)	-	< 100 °C	-	HQQE
Peanut oil		D, E, 3	100 %, 80 °C	HQQV	-
Petrol		1, 3, 4, F	100 %, 20 °C	HQBV	-
Phosphoric acid	H ₃ PO ₄	E	20 %, 20 °C	-	HQQE
Propanol	C ₃ H ₇ OH	1, F	100 %, 20 °C	HQQE	-
Propylene glycol	CH ₃ CH(OH)CH ₂ OH	D, E	50 %, < 90 °C	HQQE	-
Potassium carbonate	K ₂ CO ₃	E	20 %, 50 °C	HQQE	-
Potassium formate (as coolant with inhibitor)	KOOCH	D, E	30 %, 50 °C	HQQE	-
Potassium hydroxide	KOH	E	20 %, 50 °C	-	HQQE
Potassium permanganate	KMnO ₄	-	5 %, 20 °C	-	HQQE
Rape seed oil		D, E, 3	100 %, 80 °C	HQQV	-
Salicylic acid	C ₆ H ₄ (OH)COOH	H	0.1 %, 20 °C	-	HQQE
Silicone oil		E, 3	100 %	HQQV	-
Sodium bicarbonate	NaHCO ₃	E	10 %, 60 °C	-	HQQE

Pumped liquid	Chemical formula	Note	Liquid concentration, liquid temperature	CRE	CRNE
Sodium chloride (as coolant)	NaCl	D, E	30 %, < 5 °C, pH > 8	HQQE	-
Sodium hydroxide	NaOH	E	20 %, 50 °C	-	HQQE
Sodium hypochlorite	NaOCl	F	0.1 %, 20 °C	-	HQQV
Sodium nitrate	NaNO ₃	E	10 %, 60 °C	-	HQQE
Sodium phosphate	Na ₃ PO ₄	E, H	10 %, 60 °C	-	HQQE
Sodium sulphate	Na ₂ SO ₄	E, H	10 %, 60 °C	-	HQQE
Softened water		-	< 120 °C	-	HQQE
Soya oil		D, E, 3	100 %, 80 °C	HQQV	-
Sulphuric acid	H ₂ SO ₄	F	1 %, 20 °C	-	HQQV
Sulphurous acid	H ₂ SO ₃	-	1 %, 20 °C	-	HQQE
Unsalted swimming-pool water		-	Approx. 2 ppm free chlorine (Cl ₂)	HQQE	-

Viscosity

The pumping of liquids with densities or kinematic viscosities higher than those of water will cause a considerable pressure drop, a drop in the hydraulic performance and a rise in power consumption.

In such situations, the pump must be fitted with a larger motor. If in doubt, contact Grundfos.

Maximum operating pressure and liquid temperature

Pump type	Oval flange		PJE, clamp, union, DIN	
	Maximum permissible operating pressure [bar]	Liquid temperature [°C]	Maximum permissible operating pressure [bar]	Liquid temperature [°C]
CRE, CRIE, CRNE 1	16		25	
CRE, CRIE, CRNE 3	16	-20 - +120	25	
CRE, CRIE, CRNE 5	16		25	-20 - +120
CRE, CRIE 10-1 → 10-10	16		16	
CRE, CRIE 10-12 → 10-17	-	-	25	
CRNE 10	16	-20 - +120	25	
CRE, CRIE 15-1 → 15-5	10		-	-
CRE, CRIE 15-1 → 15-8	-	-	16	
CRE, CRIE 15-9 → 15-12	-	-	25	-20 - +120
CRNE 15	10	-20 - +120	25	
CRE, CRIE 20-1 → 20-5	10		-	-
CRE, CRIE 20-1 → 20-7	-	-	16	
CRE, CRIE 20-8 → 20-10	-	-	25	-20 - +120
CRNE 20	10	-20 - +120	25	
CRE, CRNE 32-1-1 → 32-5	-	-	16	
CRE, CRNE 32-6-2 → 32-10-2	-	-	30	
CRE, CRNE 45-1-1 → 45-4	-	-	16	
CRE, CRNE 45-5-2 → 45-7	-	-	30	-30 - +120
CRE, CRNE 64-1-1 → 64-3	-	-	16	
CRE, CRNE 95-1-1 → 95-2-1	-	-	16	
CRE, CRNE 125-1-1 → 125-1	-	-	16	
CRE, CRNE 155-1-1	-	-	16	

Note that for pump sizes 32, 45, 64, the max. pressure for PJE version is 50 bar and only available in the CRNE version.

Operating range of the shaft seal

All pumps will be delivered with a HQQE/V cartridge shaft seal as standard.

The operating range of the shaft seal depends on operating pressure, pump type, type of shaft seal and liquid temperature. The range shown in figs Operating range of standard shaft seals for CRE, CRIE, CRNE 1-155 and Operating range of standard shaft seals for CR, CRN 125-155 applies to clean water and water with antifreeze liquids. For selection of the right shaft seal, see the section on pumped liquids. If the operating range is exceeded, the life of the shaft seal may be reduced.

Note that if you pump demineralised water with a conductivity below 2 µS/cm with a pump equipped with a silicon carbide/silicon carbide shaft seal, there is an increased risk of electro corrosion. We recommend that you use a silicon carbide/carbon or silicon carbide/tungsten carbide shaft seal instead.

Optional shaft seals

See the section on variants for optional shaft seal solutions.

Related information

[Pumped liquids](#)

[CRE, CRIE, CRNE 1-155](#)

[13. Variants](#)

CRE, CRIE, CRNE 1-155

Ø12, Ø16 and Ø22 shafts seals (0.37 - 55 kW)

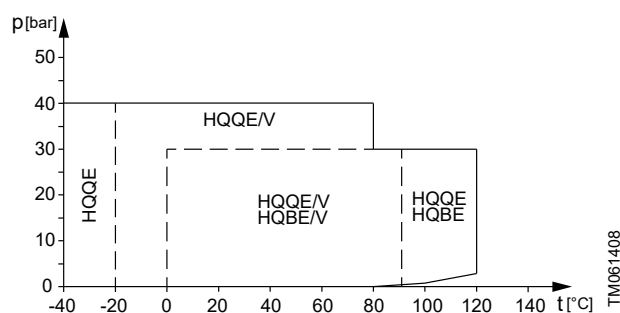

Operating range of standard shaft seals for CRE, CRIE, CRNE 1-155

Standard shaft seal	Motor size [kW]	Description	Liquid temperature [°C]
HQQE	0.37 - 55	O-ring (cartridge) (balanced seal), Silicon carbide/Silicon carbide, EPDM	-40 - +120
HQQV		O-ring (cartridge) (balanced seal), Silicon carbide/Silicon carbide, FKM	-20 - +90
HQBE		O-ring (cartridge) (balanced seal), Silicon carbide/carbon, EPDM	0 - +120
HQBV		O-ring (cartridge) (balanced seal), Silicon carbide/carbon, FKM	0 - +90

Ø28 and Ø28 shaft seals (75-110 kW)

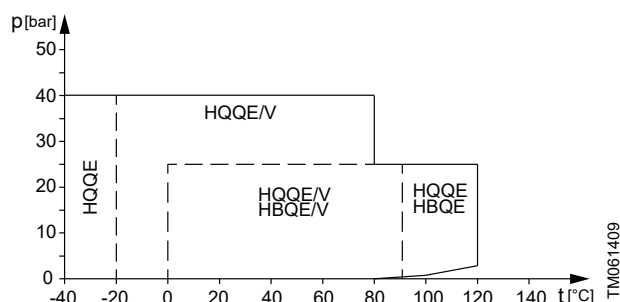

Operating range of standard shaft seals for CR, CRN 125-155

Standard shaft seal	Motor size [kW]	Description	Liquid temperature [°C]
HQQE	75-110	O-ring (cartridge) (balanced seal), Silicon carbide/Silicon carbide, EPDM	-40 - +120
HQQV		O-ring (cartridge) (balanced seal), Silicon carbide/Silicon carbide, FKM	-20 - +90
HQBE		O-ring (cartridge) (balanced seal), Silicon carbide/carbon, EPDM	0 - +120
HQBV		O-ring (cartridge) (balanced seal), Silicon carbide/carbon, FKM	0 - +90

Maximum inlet pressure

The following table shows the maximum permissible inlet pressure. However, the outlet pressure, which is the actual inlet pressure plus the pressure delivered by the pump, must always be lower than the maximum permissible operating pressure.

If the maximum permissible operating pressure is exceeded, the conical bearing in the motor may be damaged and the life of the shaft seal reduced.

Pump type and stages	Maximum inlet pressure [bar]
CRE, CRIE, CRNE 1	
1-2 → 1-25	10
1-27	15
CRE, CRIE, CRNE 3	
3-2 → 3-17	10
3-19 → 3-25	15
CRE, CRIE, CRNE 5	
5-2 → 5-9	10
5-10 → 5-24	15
CRE, CRIE, CRNE 10	
10-1 → 10-5	8
10-6 → 10-17	10
CRE, CRIE, CRNE 15	
15-1 → 15-2	8
15-3 → 15-12	10
CRE, CRIE, CRNE 20	
20-1	8
20-2 → 20-10	10
CRE, CRNE 32	
32-1-1 → 32-2	4
32-3-2 → 32-6	10
32-7-2	15
CRE, CRNE 45	
45-1-1 → 45-1	4
45-2-2 → 45-3	10
45-4-2	15
CRE, CRNE 64	
64-1-1	4
64-1 → 64-2-1	10
64-2 → 64-3-2	15
CRE, CRNE 95	
95-1-1 → 95-2-1	10
CRE, CRNE 125	
125-1-1 → 125-1	10
CRE, CRNE 155	
155-1-1	10

Examples of operating and inlet pressures

The values for operating and inlet pressures must not be considered individually and must comply with the below statement.

The outlet pressure must be equal to or lower than the maximum operating pressure.

See the following definitions and examples.

Definitions

Pressure type	Definition
Maximum operating pressure	The maximum pressure is stated on the nameplate.
Pump differential pressure	The difference between the outlet pressure and inlet pressure.
Inlet pressure	The pressure measured at the pump inlet.
Outlet pressure	The inlet pressure added to the pump differential pressure.

Example 1

Pump, see the section on CRE3:	CRE 3-11 A-A-A
Max. operating pressure:	16 bar
Max. inlet pressure:	10 bar
Pump differential pressure:	10.3 bar ²⁵⁾

²⁵⁾ Flow rate = 0 m³/h

This pump is not allowed to start at an inlet pressure of 10 bar, but at an inlet pressure of 16.0 - 10.3 = 5.7 bar.

Example 2

Pump, see the section on CRE 10:	CRE 10-2 A-A-A
Max. operating pressure:	16 bar
Max. inlet pressure:	8 bar
Pump differential pressure:	2.9 bar ²⁶⁾

²⁶⁾ Flow rate = 0 m³/h

This pump is allowed to start at an inlet pressure of 8 bar, as the outlet pressure is lower than the maximum operating pressure. This results in an operating pressure of 8.0 + 2.9 = 10.9 bar.

If the inlet or operating pressure exceeds the pressure permitted, see the section on variants.

Related information

[CRE 3](#)

[CRE 10](#)

[13. Variants](#)

Control of E-pumps

Control options

It is possible to communicate with E-pumps via the following platforms:

- operating panel on the pump
- Grundfos GO
- Grundfos GO Link
- central management system.

The purpose of controlling an E-pump is to monitor and control the pressure, temperature, flow and liquid level of the system.

Operating panels

The operating panel on the E-pump terminal box makes it possible to change the setpoint settings manually. All settings are saved if the power supply is switched off.

The following operating panels are available as standard:

- HMI 200
- HMI 300

Note that these panels include an integrated radio module.

The following operating panels, without an integrated radio module, are available on request:

- HMI 100
- HMI 101
- HMI 201
- HMI 301

For further information, see the section on variants.

Related information

[13. Variants](#)

HMI 200

This operating panel is available as standard.

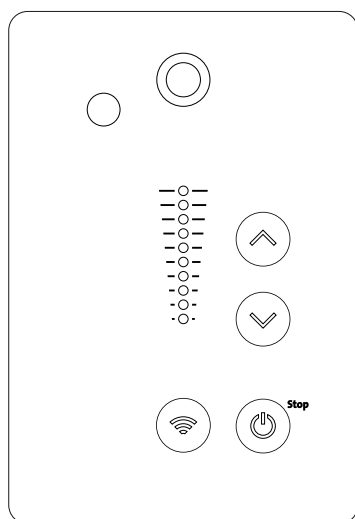

TM084861

HMI 300

This operating panel is available as either standard or an option depending on the region.

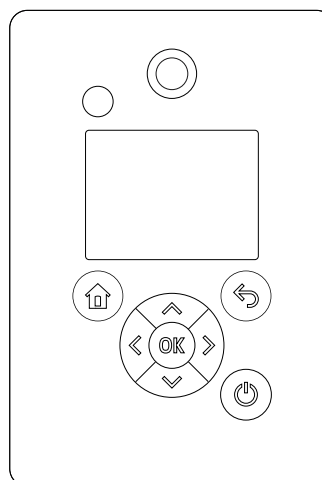

TM084862

Grundfos GO

Grundfos GO enables you to set functions and gives you access to status overviews, technical product information and current operating parameters.

MGE 0.37 to 11 kW

The product is designed for wireless radio or infrared communication with Grundfos GO.

Use Grundfos GO together with this mobile interface:

- Grundfos MI 301.

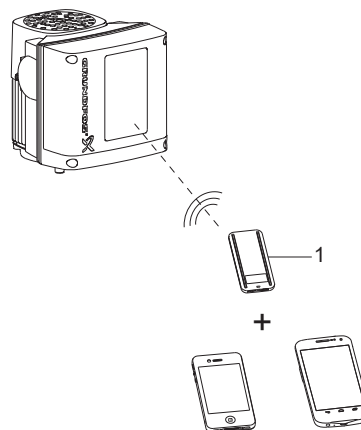

TM066256

Pos.	Description
1	Grundfos MI 301: Separate module enabling radio or infrared communication. Use the module together with an Android or iOS-based smart device via a Bluetooth connection.

MGE 15 to 26 kW

The product is designed for wireless communication with Grundfos GO using Bluetooth (BLE).

Via the built-in Bluetooth module, the product can communicate with Grundfos GO.

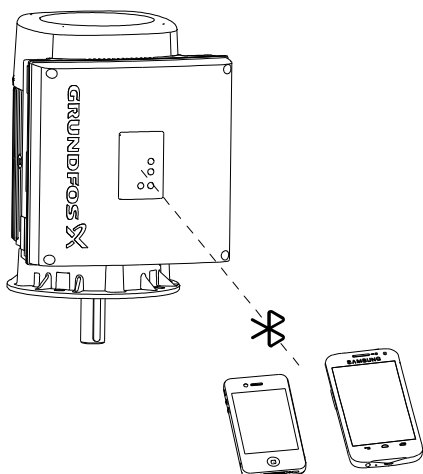

TM082930

Related information

Grundfos GO

Central management system

Communication with the E-pump is possible even if the operator is not present near the E-pump. Communication is enabled by connecting the E-pump to a central building management system. This allows the operator to monitor the pump and change control modes and setpoint settings.

Communication between E-pumps and a central building management system is enabled via a Grundfos CIM module.

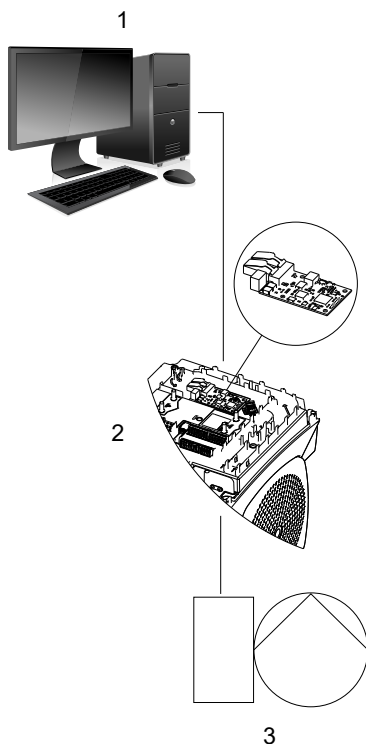

TM084691

Structure of a central management system

Pos.	Description
1	Central management system
2	CIM modules (See the section on CIM communication interface modules)
3	E-pump

Related information

CIM communication interface modules

Control modes

E-pumps are available in two variants:

- with integrated pressure sensor
- without sensor.

E-pumps with an integrated pressure sensor

Use an E-pump with an integrated pressure sensor in applications where you want to control the pressure of the pump, irrespective of the flow rate. For further information, see the section on examples of E-pump applications.

Signals of pressure changes in the pipe system are transmitted continuously from the sensor to the pump. The pump responds to the signals by adjusting its performance up and down to compensate for the pressure difference between the actual and the desired pressure. As this adjustment is a continuous process, a constant pressure is maintained in the pipe system.



TM070573

CRE, CRIE and CRNE pumps

An E-pump with an integrated pressure sensor facilitates installation and startup.

The control mode can be set to either of these:

- constant pressure (factory setting)
- constant curve.

In constant-pressure mode, the pump maintains a preset pressure irrespective of the flow rate. See the figure below.

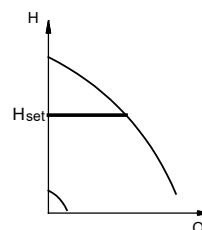

TM009322

Constant-pressure mode

In constant-curve mode, the pump is not controlled. It can be set to pump according to a preset pump characteristic curve within the range from the minimum curve to the maximum curve. See the figure below.

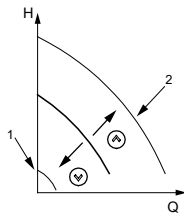

TM009323

Constant-curve mode

Pos.	Description
1	Min.
2	Max.

Related information*Examples of E-pump applications***E-pumps without a sensor**

E-pumps without a sensor are suitable in these situations:

- Uncontrolled operation is required.
- The sensor has been retrofitted to control the flow rate, temperature, differential temperature, liquid level and pH value at some arbitrary point in the system.

E-pumps without a sensor can be set to any of these control modes:

- constant pressure
- constant differential pressure
- constant temperature
- constant differential temperature
- constant flow rate
- constant level
- constant curve
- constant other value.

E-pumps without a sensor can be set to either of these control modes:

- controlled operation
- uncontrolled operation (factory setting).

In controlled-operation mode, the pump adjusts its performance to the desired setpoint. See the figure below.

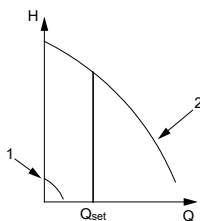

TM027264

Constant-flow mode

Pos.	Description
1	Min.
2	Max.

In uncontrolled-operation mode, the pump operates according to the constant curve set. See the figure below.

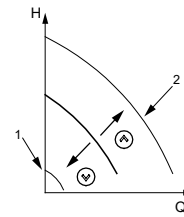

TM009323

Constant-curve mode

Pos.	Description
1	Min.
2	Max.

E-pumps can be fitted with a sensor type meeting the requirements mentioned in the Grundfos E-pumps data booklet available in Grundfos Product Center at www.grundfos.com.

9. Selection

Selection of pumps

Base the selection of pumps on these parameters:

- Duty point of the pump. See the section on duty point of the pump.
- Sizing data such as pressure loss as a result of height differences, friction loss in the pipes, pump efficiency. See the section on sizing data.
- Pump materials. See the section on pump material.
- Pump connections. See the section on pump connections.
- Shaft seal. See the section on shaft seal.

Duty point of the pump

From a duty point, you can select a pump on the basis of the curve charts in the section on performance curves and technical data.

Ideally, the duty point should match the best efficiency on the pump curve.

Related information

- [Pump efficiency](#)
- [CRE 1](#)

Grundfos Product Center

We recommend that you size your pump in Grundfos Product Center, which is a selection program offered by Grundfos. For further information, see the section on Grundfos Product Center.

Grundfos Product Center features a user-friendly and easy-to-use virtual guide which leads you through the selection of the pump for the application in question.

Related information

- [14. Grundfos Product Center](#)

Sizing data

When sizing a pump, take these parameters into account:

- Required flow rate and pressure at the draw-off point
- Pressure loss as a result of height differences (H_{geo})
- Friction loss in the pipes (H_f)

It may be necessary to account for pressure loss in connection with long pipes, bends, valves or similar.

- Best efficiency at the estimated duty point
- NPSH value

For calculation of the NPSH value, see the section on minimum inlet pressure, NPSH.

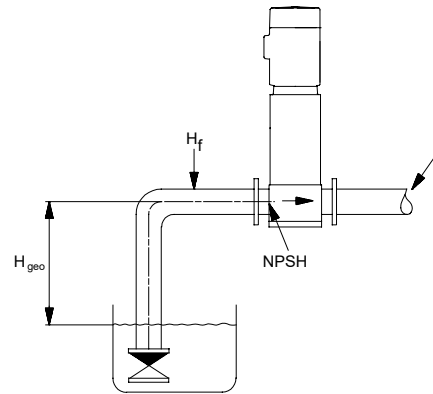

TM026711

Sizing data

Pos.	Description
1	Required flow rate, required pressure

Pump efficiency

Before determining the best efficiency point, identify the operation pattern of the pump. If you expect the pump to always operate at the same duty point, then select a pump which operates at a duty point corresponding to the best efficiency of the pump.

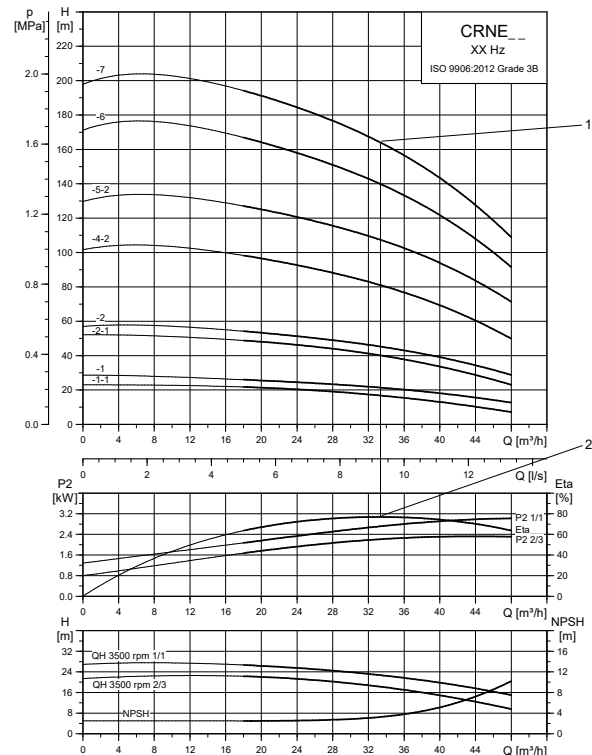

TM1040084

Example of a CRE pump's duty point

Pos.	Description
1	Duty point
2	Best efficiency

As the pump is sized on the basis of the highest possible flow rate, it is important to always have the duty point to the right of the best efficiency point on the efficiency curve (eta). This must be considered in order to keep the efficiency high when the flow rate drops.

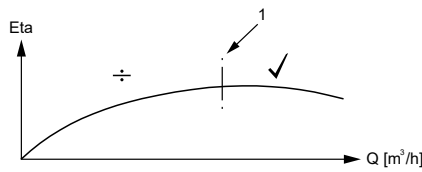

TM0009190

Best efficiency

Pos.	Description
1	Best efficiency point

Affinity equations

Normally, speed-regulated pumps are used in applications characterized by a variable flow rate. Consequently, you cannot select a pump that is constantly operating at its optimum efficiency.

To achieve optimum operating economy, select the pump on the basis of the following criteria:

- The maximum duty point must be as close as possible to the QH curve of the pump.
- The required duty point must be positioned so that P2 is close to the maximum point of the QH curve.

The flow rate of the required duty point must be close to the optimum efficiency (eta) for most operating hours.

Between the minimum and maximum performance curves, speed-regulated pumps have an infinite number of performance curves, each representing a specific speed. You may therefore not be able to select a duty point close to the maximum curve.

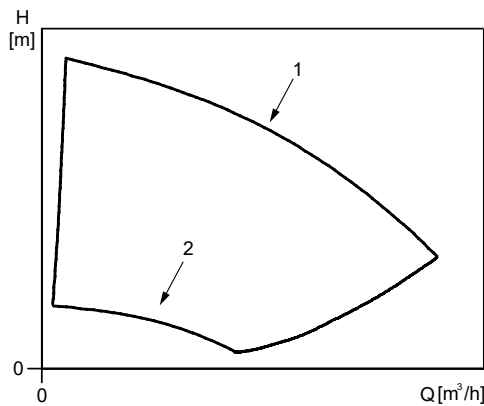

TM014916

Maximum (1) and minimum (2) performance curves

In situations where you cannot select a duty point close to the maximum curve, use the affinity equations below. The head (H), the flow rate (Q) and the input power (P) are the appropriate variables for calculating the motor speed (n).

Note that the approximated formulas apply on condition that the system characteristic remains unchanged for n_n and n_x and that it is based on the formula $H = k \times Q^2$ where k is a constant.

The power equation implies that the pump efficiency is unchanged at the two speeds. In practice, this is not quite correct.

To obtain a precise calculation of the power savings resulting from a reduction of pump speed, take into account the efficiencies of the frequency converter and the motor.

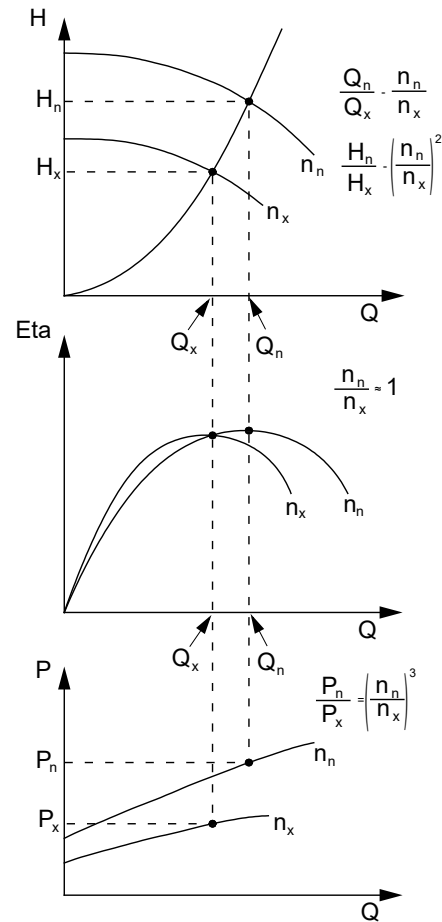

TM0008720

Affinity equations

Legend

H_n	Rated head [m]
H_x	Current head [m]
Q_n	Rated flow rate [m³/h]
Q_x	Current flow rate [m³/h]
n_n	Rated motor speed [min ⁻¹]
n_x	Current motor speed [min ⁻¹]
η_n	Rated efficiency [%]
η_x	Current efficiency [%]
P_n	Rated power [kW]
P_x	Current power [kW]

Pump material

Select the material variant on the basis of the liquid to be pumped.

The product range covers the following basic types:

- CRE, CRIE: Use CRE, CRIE pumps for clean, non-aggressive liquids such as potable water and oils.

- CRNE: Use CRNE pumps for industrial liquids and acids. See the section on pumped liquids, or contact Grundfos.

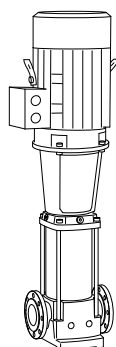

CR pump

Related information

Pumped liquids

Pump connections

Selection of a pump connection depends on the rated pressure and pipes. To meet any requirement, the pumps offer a wide range of flexible connections, such as the following:

- oval flange A (BSP)
- DIN flange
- PJE coupling
- clamp coupling
- union (+GF+)
- other connections on request.

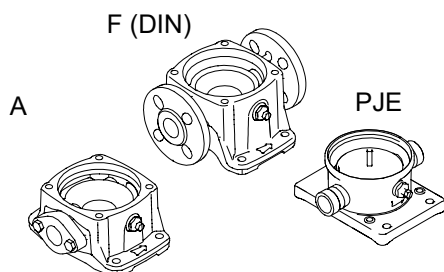

Pump connections

Shaft seal

As standard, the product range is fitted with a Grundfos shaft seal (cartridge type) which is suitable for the most common applications.

The following key parameters must be taken into account when selecting the shaft seal:

- type of pumped liquid
- liquid temperature
- maximum pressure.

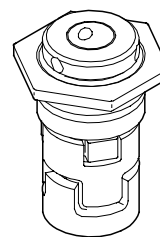

Shaft seal (cartridge type)

We offer a wide range of shaft seal variants to meet specific demands according to the pumped liquid.

Servicing shaft seals

Replacement shaft seals are available as complete service kits ²⁷⁾.

Shaft seals fitted on CR, CRN 125-155 pumps with Ø28 mm or Ø36 mm shaft ends are serviceable. This means that the wear parts in these shaft seals are available as service kits ²⁷⁾ and can be replaced without having to renew the complete shaft seal.

Operating pressure and inlet pressure

Do not exceed the limit values for these pressures:

- maximum operating pressure
- maximum inlet pressure.

Minimum inlet pressure, NPSH

We recommend calculating the inlet pressure "H" in these situations:

- The liquid temperature is high.
- The flow is significantly higher than the rated flow.
- Water is drawn from depths.
- Water is drawn through long pipes.
- Inlet conditions are poor.

To avoid cavitation, make sure that there is a minimum pressure on the inlet side of the pump.

The maximum suction lift "H" in metres head can be calculated as follows:

H	=	$p_b \times 10.2 - NPSH - H_f - H_v$
p_b	=	Barometric pressure in bar. p_b can be set to 1 bar at sea level. In closed systems, p_b indicates the system pressure in bar.
NPSH	=	Net Positive Suction Head in metres head. To be read from the NPSH curve at the highest flow the pump will be delivering.
H_f	=	Friction loss in inlet pipe in metres head at the highest flow the pump will be delivering.
H_v	=	Vapour pressure in metres head To be read from the vapour pressure scale. H_v depends on the liquid temperature t_m .

If the calculated "H" is positive, the pump can operate at a suction lift of maximum "H" metres head.

If the calculated "H" is negative, an inlet pressure of minimum "H" metres head is required.

TM012100

TM021201

TM020538

²⁷⁾ All service kits include detailed instructions on how to carry out the replacement.

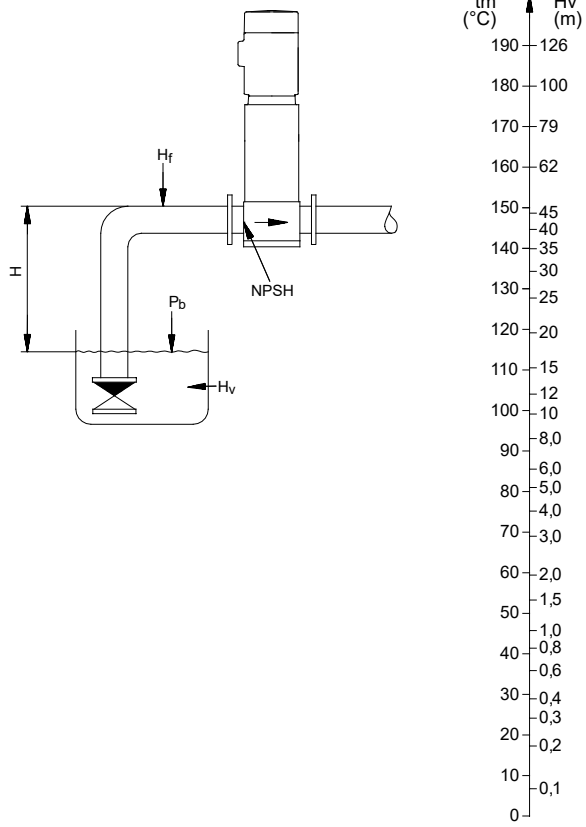

Minimum inlet pressure, NPSH

To avoid cavitation, never select a pump with a duty point too far to the right on the NPSH curve.

Always check the NPSH value of the pump at the highest possible flow.

Related information

[13. Variants](#)

How to read the curve charts

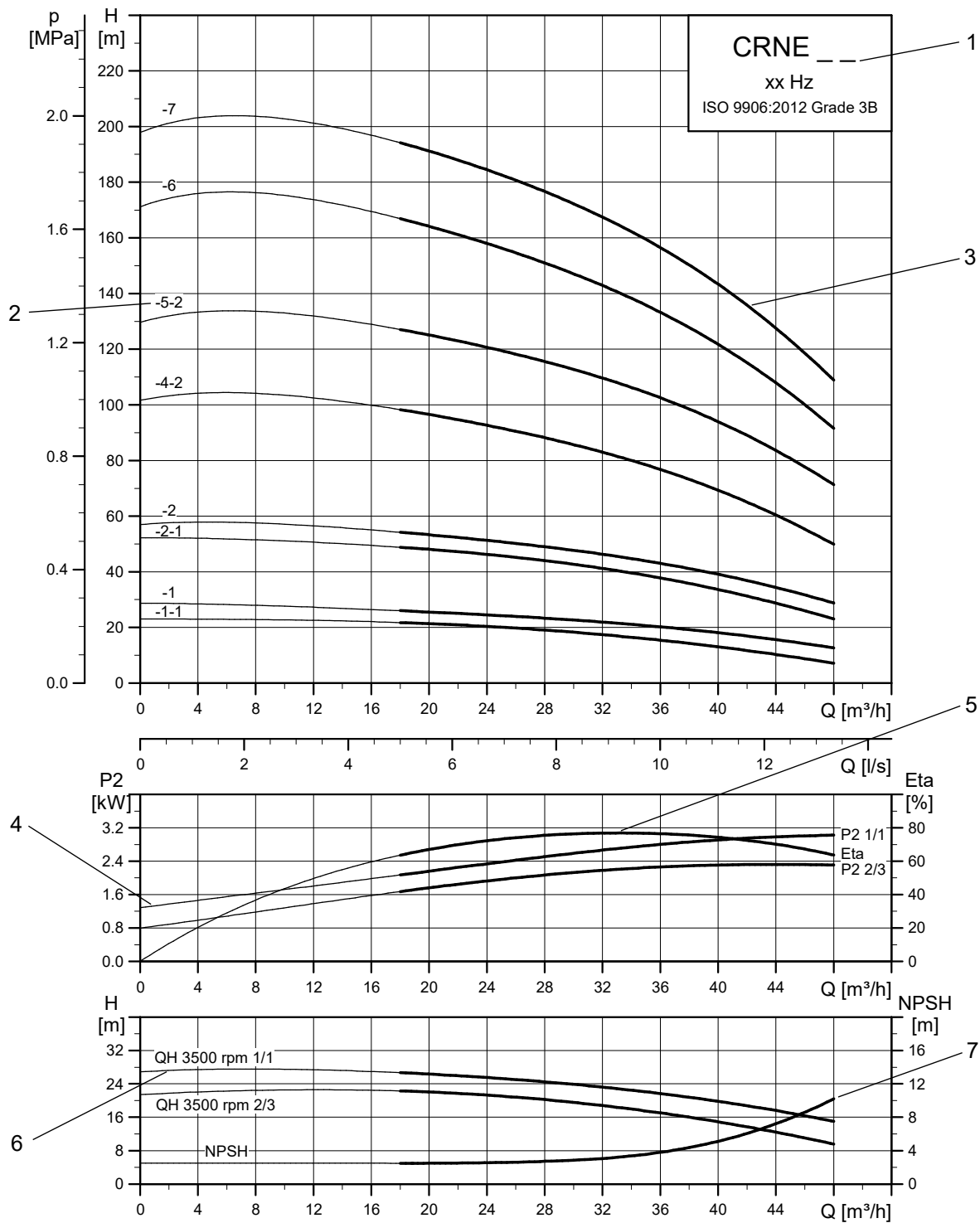

Pos.	Description
1	Pump type. Frequency. ISO standard.
2	Number of stages. First figure: number of stages. Second figure: number of reduced-diameter impellers.
3	QH curve of the individual pump. The bold curves indicate the recommended duty range for best efficiency.
4	The power curves indicate pump input power per stage . Curves are shown for full (1/1) and for reduced-diameter (2/3) impellers.
5	The eta curve shows the efficiency of a pump with an average number of stages. The efficiency of pumps with reduced-diameter impellers is approximately 2 % lower than the eta curve shown in the chart.
6	QH curve for each individual impeller. Curves are shown for full (1/1) and for reduced-diameter (2/3) impellers.
7	The NPSH curve is a maximum curve for all the variants shown.

Guidelines to performance curves

The guidelines below apply to the performance curves:

- Tolerances to ANSI or ISO standards, such as ISO 9906:2012, Grade 3B, if indicated on the curve chart.
- The motors used for the measurements are standard Grundfos-specified motors.
- Measurements have been made with airless water at a temperature of 20 °C.
- The curves apply to the following kinematic viscosity: $\nu = 1 \text{ mm}^2/\text{s}$ (1 cSt).
- Due to the risk of overheating, the pumps must not be used at a flow rate below the minimum flow rate.
- The QH curves apply to a rated motor speed of a three-phase mains-operated motor. For realistic curves, go to Grundfos Product Center (<http://product-selection.grundfos.com>) and insert data.

The curve below shows the minimum flow rate as a percentage of the rated flow rate in relation to the liquid temperature. The dotted line shows a CR pump fitted with an air-cooled top assembly.

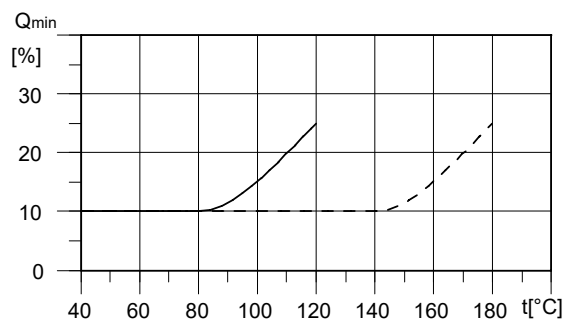

TMD012816

Minimum flow rate

10. Performance curves and technical data

CRE 1

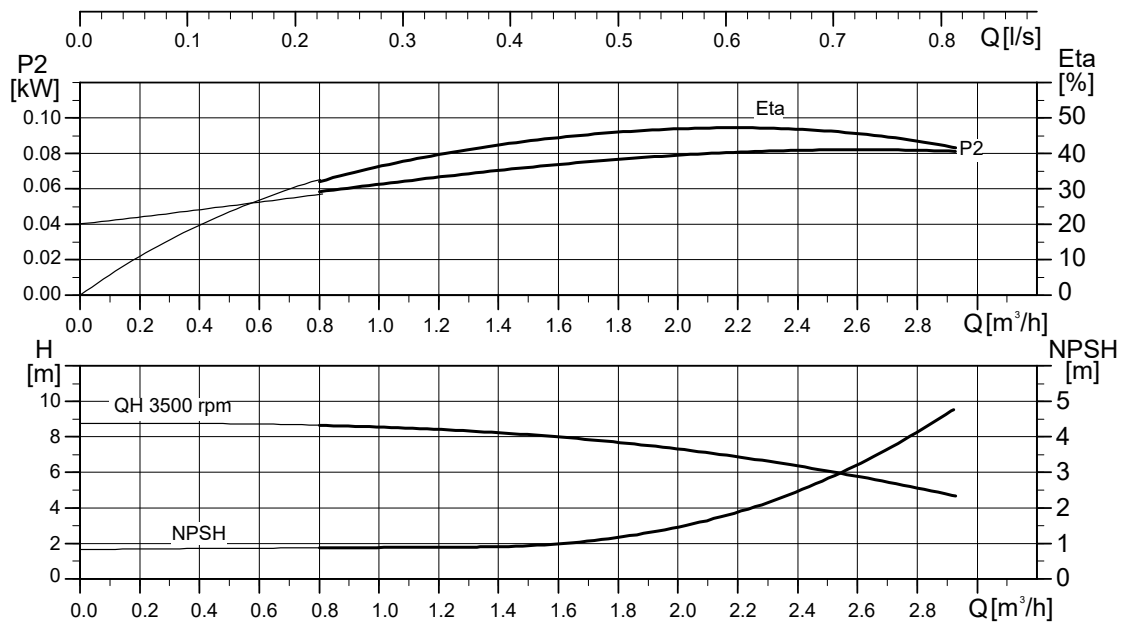
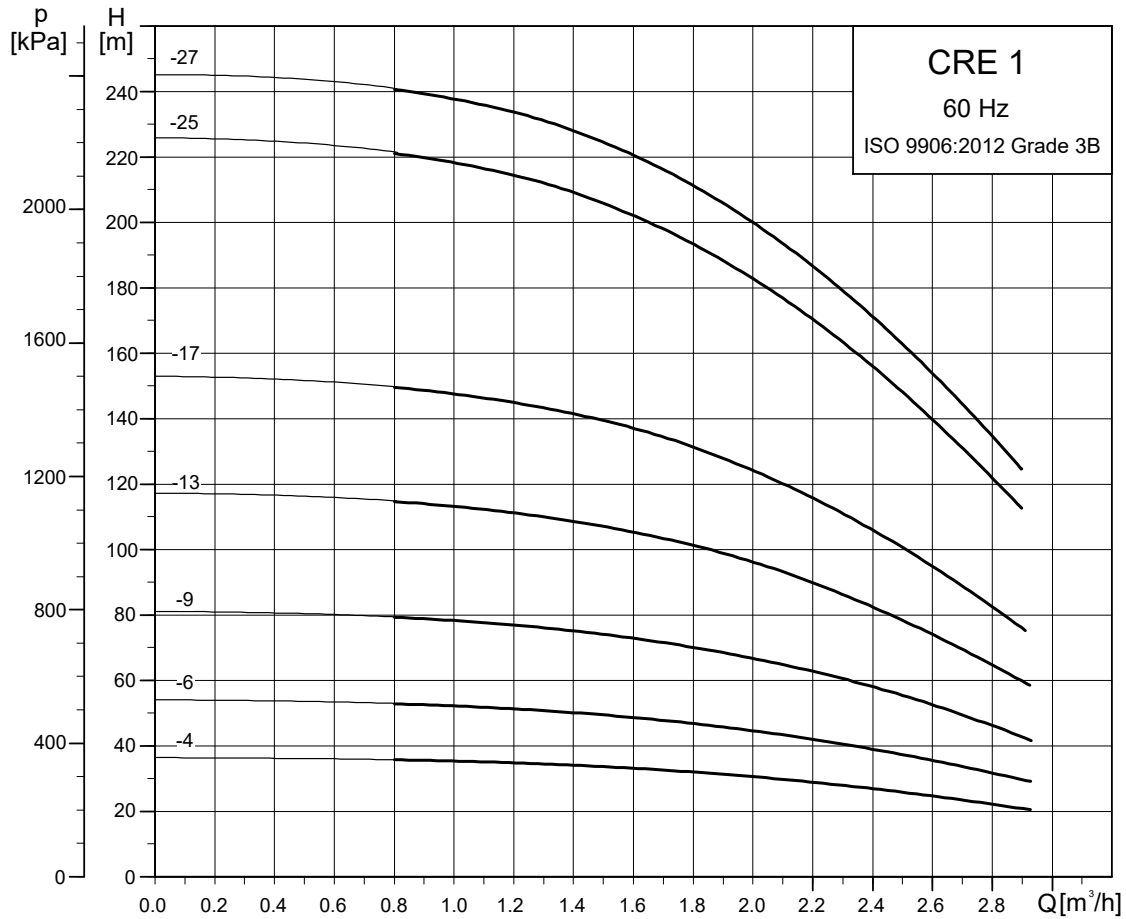

TM056833

Dimensional sketches

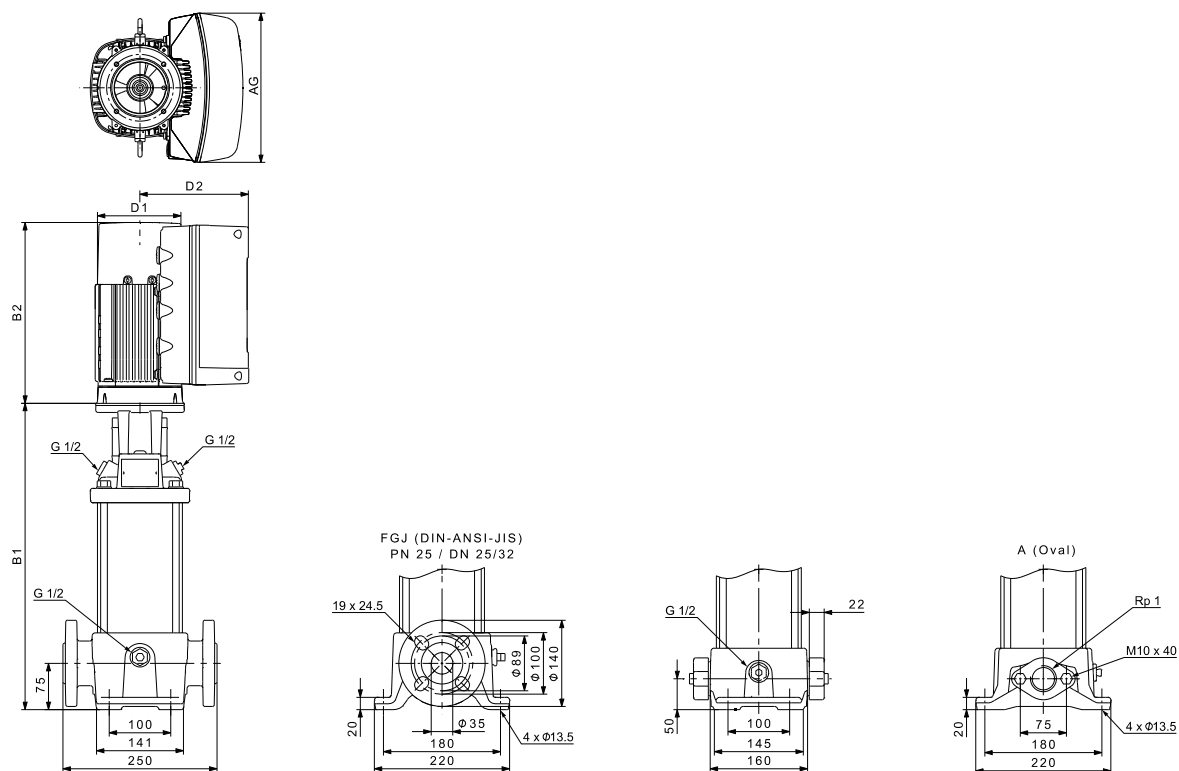

TM059394

Dimensions and weights

Pump type	P ₂ [kW]	CRE								
		Dimension [mm]						Net weight [kg]		
		Oval flange		DIN flange		D1	D2	AG	Oval flange	DIN flange
B1	B1+B2	B1	B1+B2							
CRE 1-4	0.37	272	486	297	511	122	158	212	22	26
CRE 1-6	0.55	308	522	333	547	122	158	212	22	27
CRE 1-9	0.75	368	582	393	607	122	158	212	24	29
CRE 1-13	1.1	440	654	465	679	122	158	212	27	31
CRE 1-17	1.5	528	802	553	827	122	158	268	33	38
CRE 1-25	2.2	-	-	697	971	178	167	268	-	42
CRE 1-27	3	-	-	737	1072	191	201	291	-	59

Pumps fitted with single-phase MGE motors (0.37, 0.55, 0.75 or 1.1 kW) can as an option be fitted with three-phase MGE motors.

Pumps fitted with 1.5 kW three-phase MGE motors can as an option be fitted with single-phase MGE motors.

See Grundfos Product Center for dimensions.

CRIE, CRNE 1

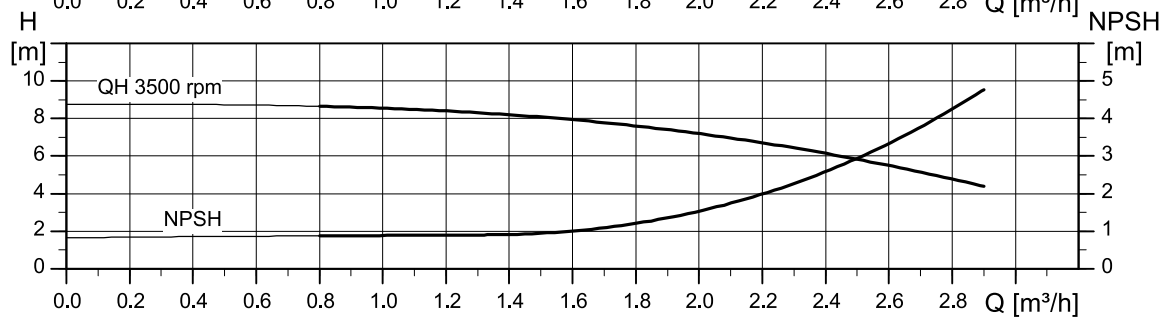
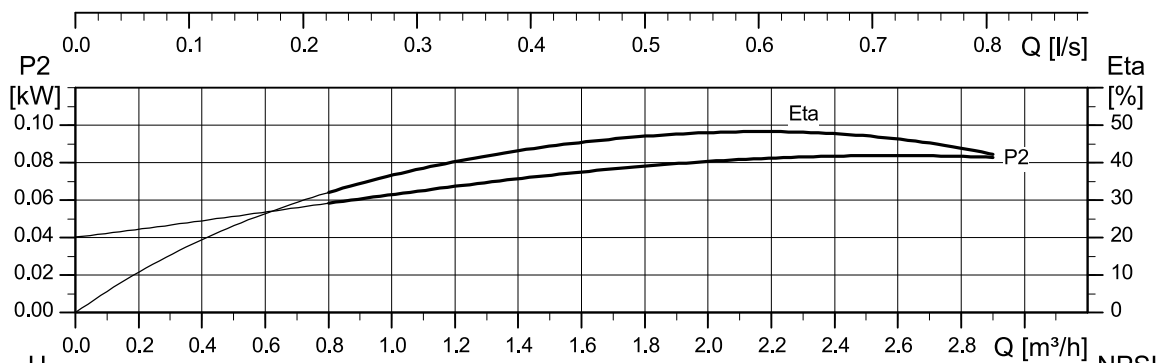
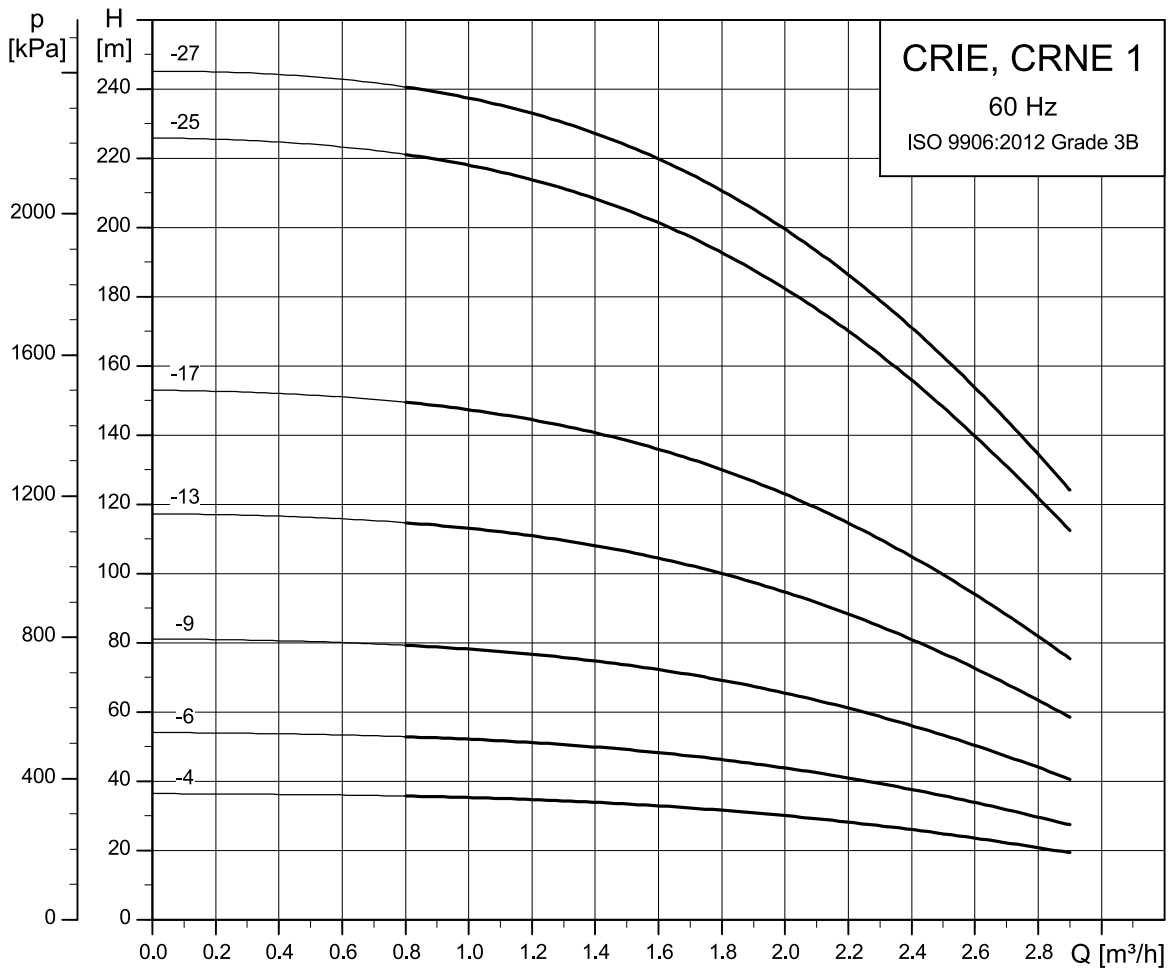

TM056834

Dimensional sketches

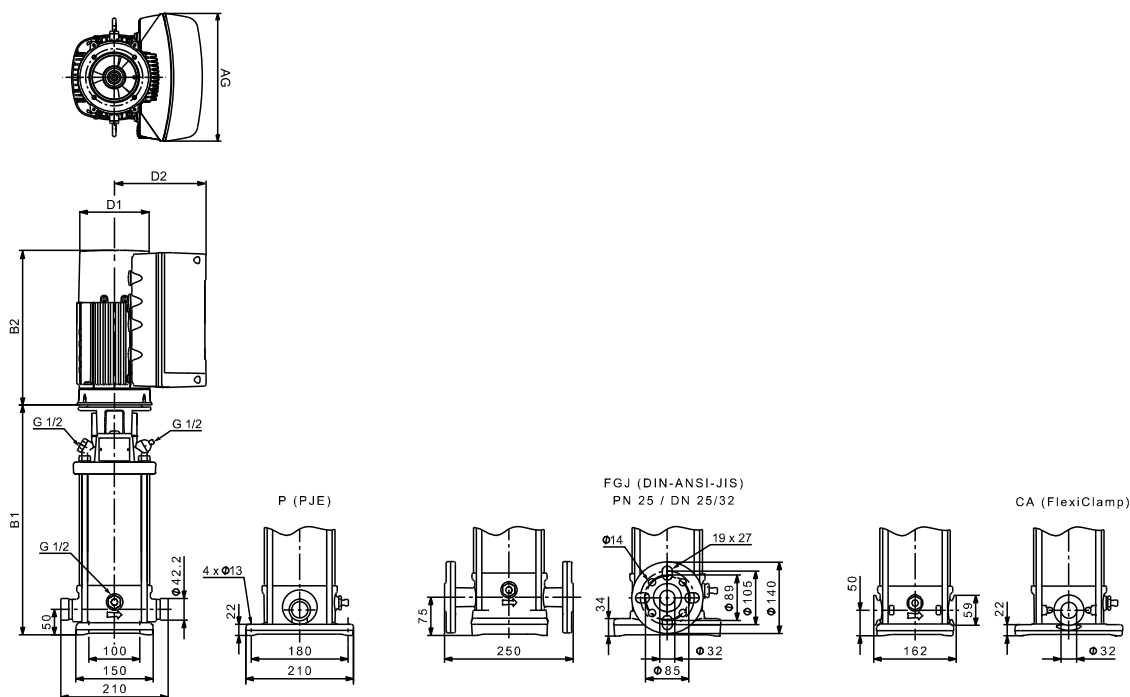

TM059395

Dimensions and weights

Pump type	P ₂ [kW]	CRE								
		Dimension [mm]						Net weight [kg]		
		PJE/CA		DIN flange		D1	D2	AG	PJE/CA	DIN flange
		B1	B1+B2	B1	B1+B2					
CRIE, CRNE 1-4	0.37	275	489	300	514	122	158	212	20	24
CRIE, CRNE 1-6	0.55	311	525	336	550	122	158	212	21	25
CRIE, CRNE 1-9	0.75	371	585	396	610	122	158	212	23	27
CRIE, CRNE 1-13	1.1	443	657	468	682	122	158	212	26	30
CRIE, CRNE 1-17	1.5	531	805	556	830	122	158	268	31	35
CRIE, CRNE 1-25	2.2	675	949	700	974	122	158	268	36	40
CRIE, CRNE 1-27	3	716	1050	741	1075	191	201	291	44	48

Pumps fitted with single-phase MGE motors (0.37, 0.55, 0.75 or 1.1 kW) can as an option be fitted with three-phase MGE motors.

Pumps fitted with 1.5 kW three-phase MGE motors can as an option be fitted with single-phase MGE motors.

See Grundfos Product Center for dimensions.

CRE 3

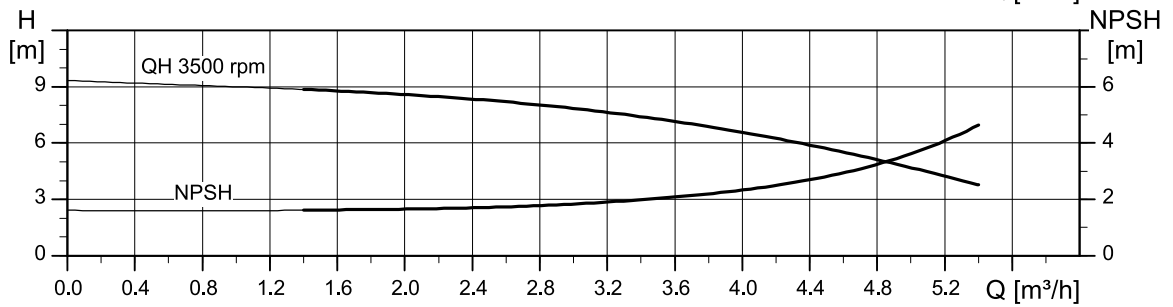
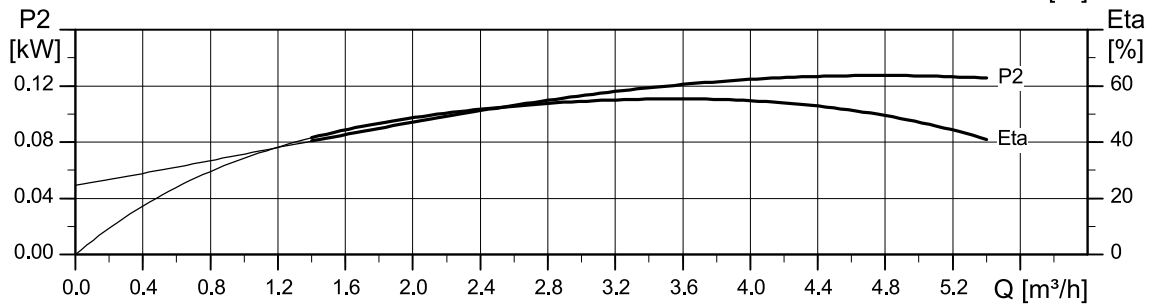
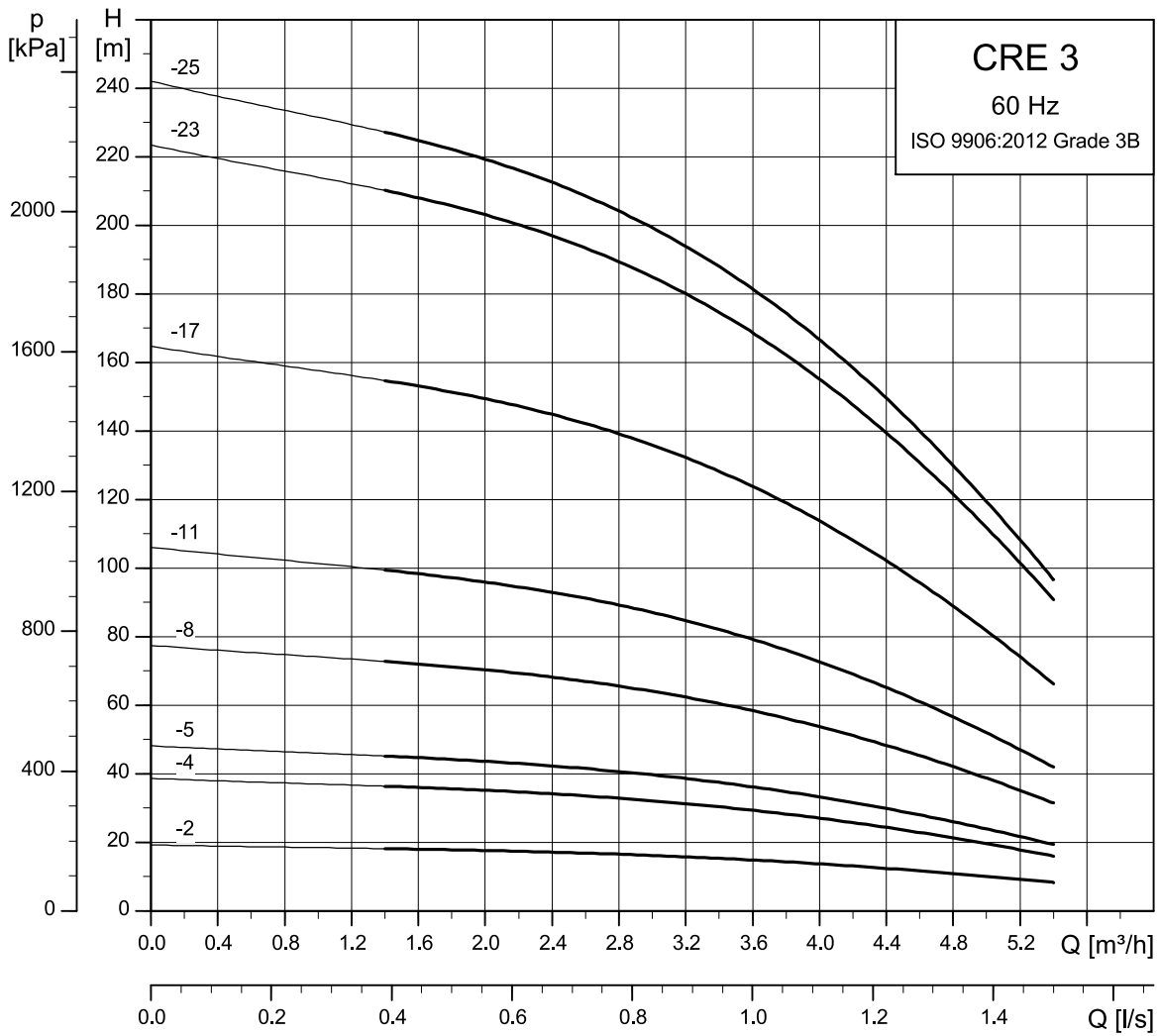

TM056835

Dimensional sketches

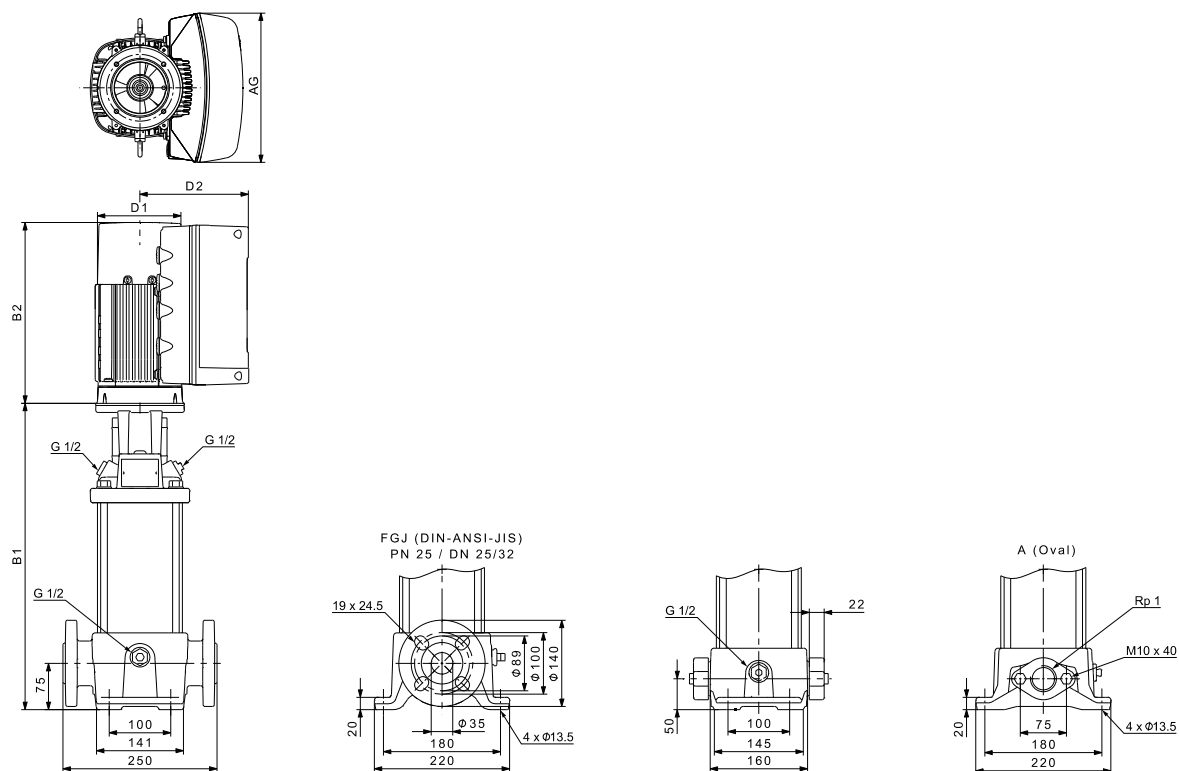

TM059394

Dimensions and weights

Pump type	P ₂ [kW]	CRE								
		Dimension [mm]				Net weight [kg]				
		Oval flange		DIN flange		D1	D2	AG	Oval flange	DIN flange
B1	B1+B2	B1	B1+B2							
CRE 3-2	0.37	254	468	279	493	122	158	212	21	26
CRE 3-4	0.55	272	486	297	511	122	158	212	22	26
CRE 3-5	0.75	296	510	321	535	122	158	212	23	27
CRE 3-8	1.1	350	564	375	589	122	158	212	25	29
CRE 3-11	1.5	420	694	445	719	122	158	268	31	35
CRE 3-17	2.2	528	849	553	827	122	158	268	46	39
CRE 3-23	3	-	-	665	999	191	201	291	-	48
CRE 3-25	4	-	-	701	1035	191	201	291	-	57

Pumps fitted with single-phase MGE motors (0.37, 0.55, 0.75 or 1.1 kW) can as an option be fitted with three-phase MGE motors.

Pumps fitted with 1.5 kW three-phase MGE motors can as an option be fitted with single-phase MGE motors.

See Grundfos Product Center for dimensions.

CRIE, CRNE 3

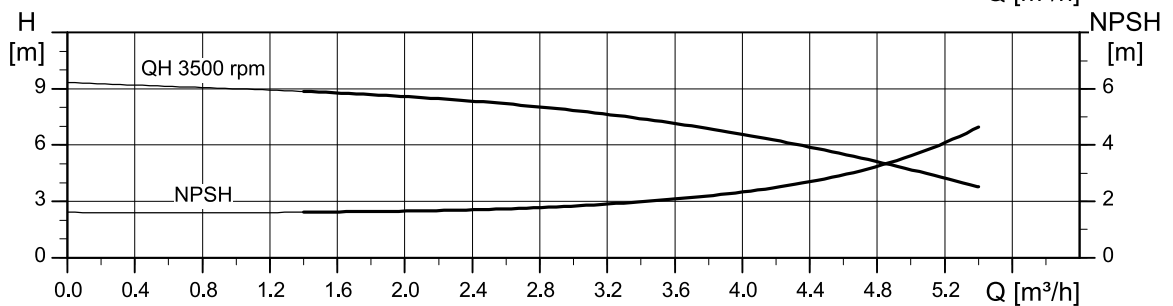
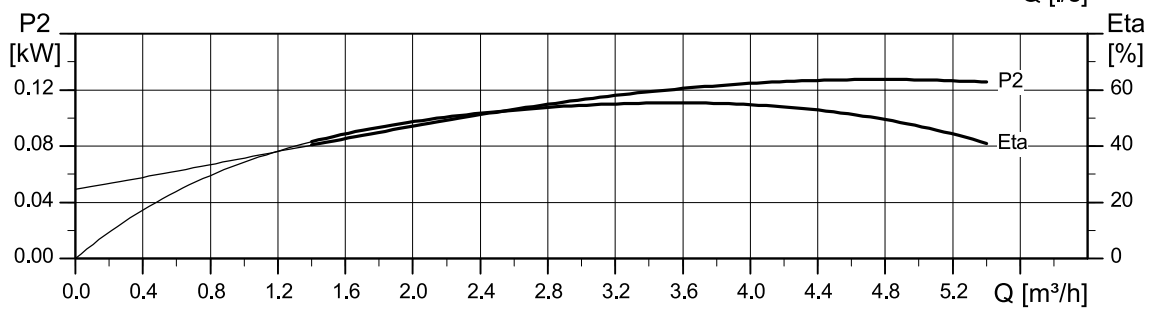
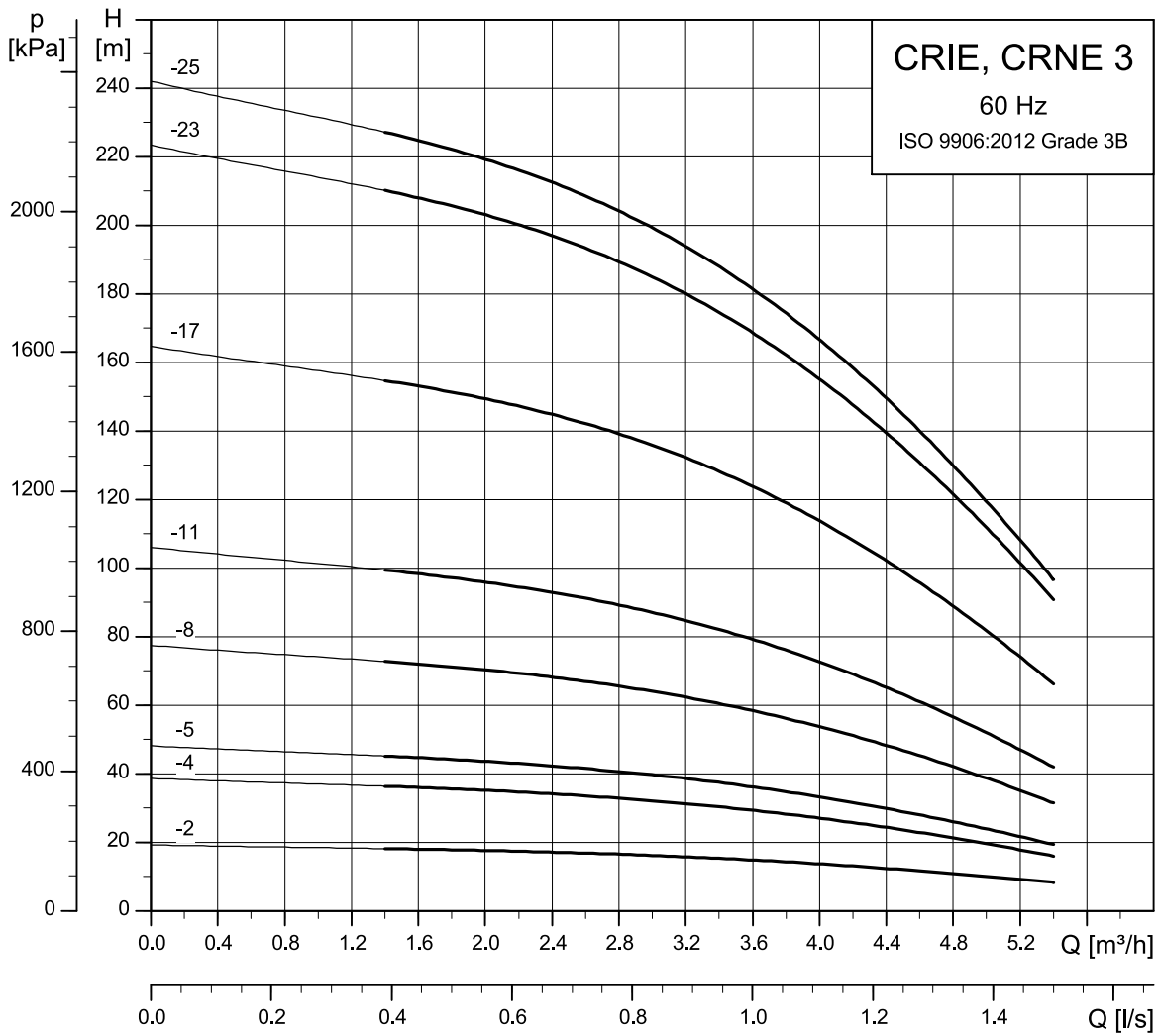

TM056836

Dimensional sketches

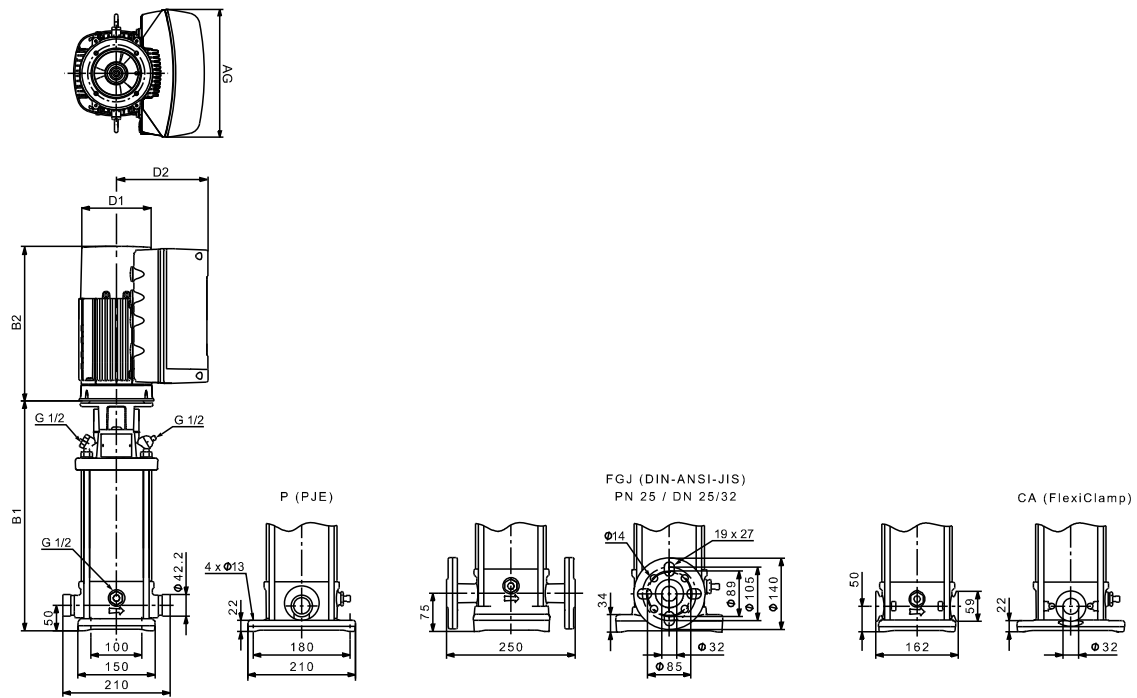

TM059395

Dimensions and weights

Pump type	P ₂ [kW]	CRIE/CRNE								
		Dimension [mm]						Net weight [kg]		
		PJE/CA		DIN flange		D1	D2	AG	PJE/CA	DIN flange
		B1	B1+B2	B1	B1+B2					
CRIE, CRNE 3-2	0.37	257	471	282	496	122	158	212	19	23
CRIE, CRNE 3-4	0.55	275	489	300	514	122	158	212	20	24
CRIE, CRNE 3-5	0.75	299	513	324	538	122	158	212	22	26
CRIE, CRNE 3-8	1.1	353	567	378	592	122	158	212	24	28
CRIE, CRNE 3-11	1.5	423	657	448	682	122	158	268	27	31
CRIE, CRNE 3-17	2.2	531	805	556	830	122	158	268	33	37
CRIE, CRNE 3-23	3	644	978	669	1003	191	201	291	42	46
CRIE, CRNE 3-23	3	644	978	705	1039	191	201	291	42	55

Pumps fitted with single-phase MGE motors (0.37, 0.55, 0.75 or 1.1 kW) can as an option be fitted with three-phase MGE motors.

Pumps fitted with 1.5 kW three-phase MGE motors can as an option be fitted with single-phase MGE motors.

See Grundfos Product Center for dimensions.

CRE 5

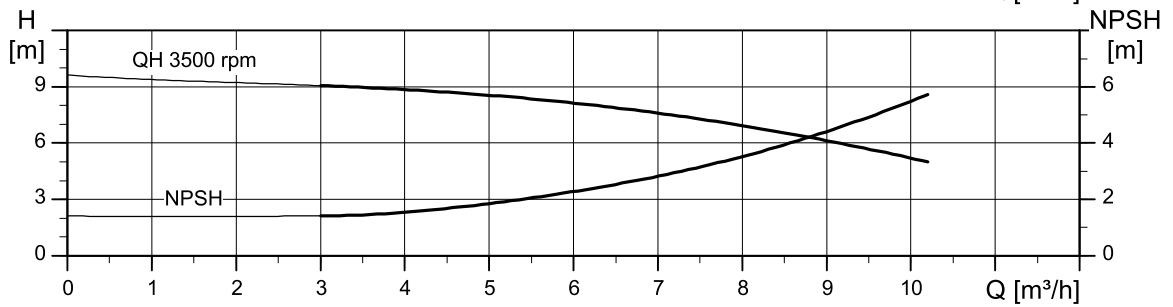
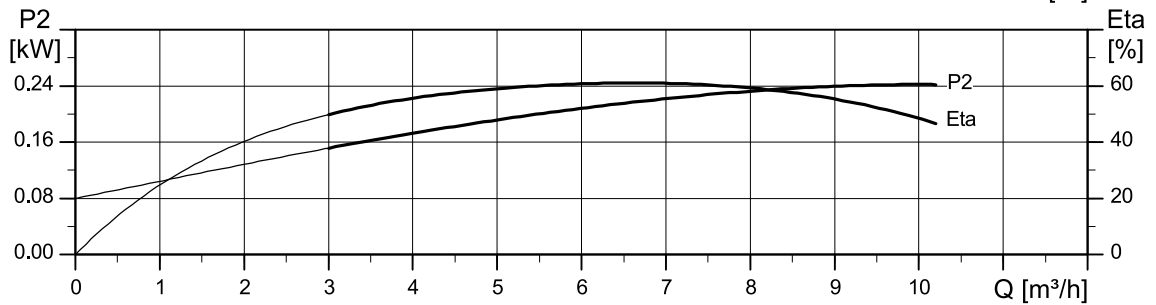
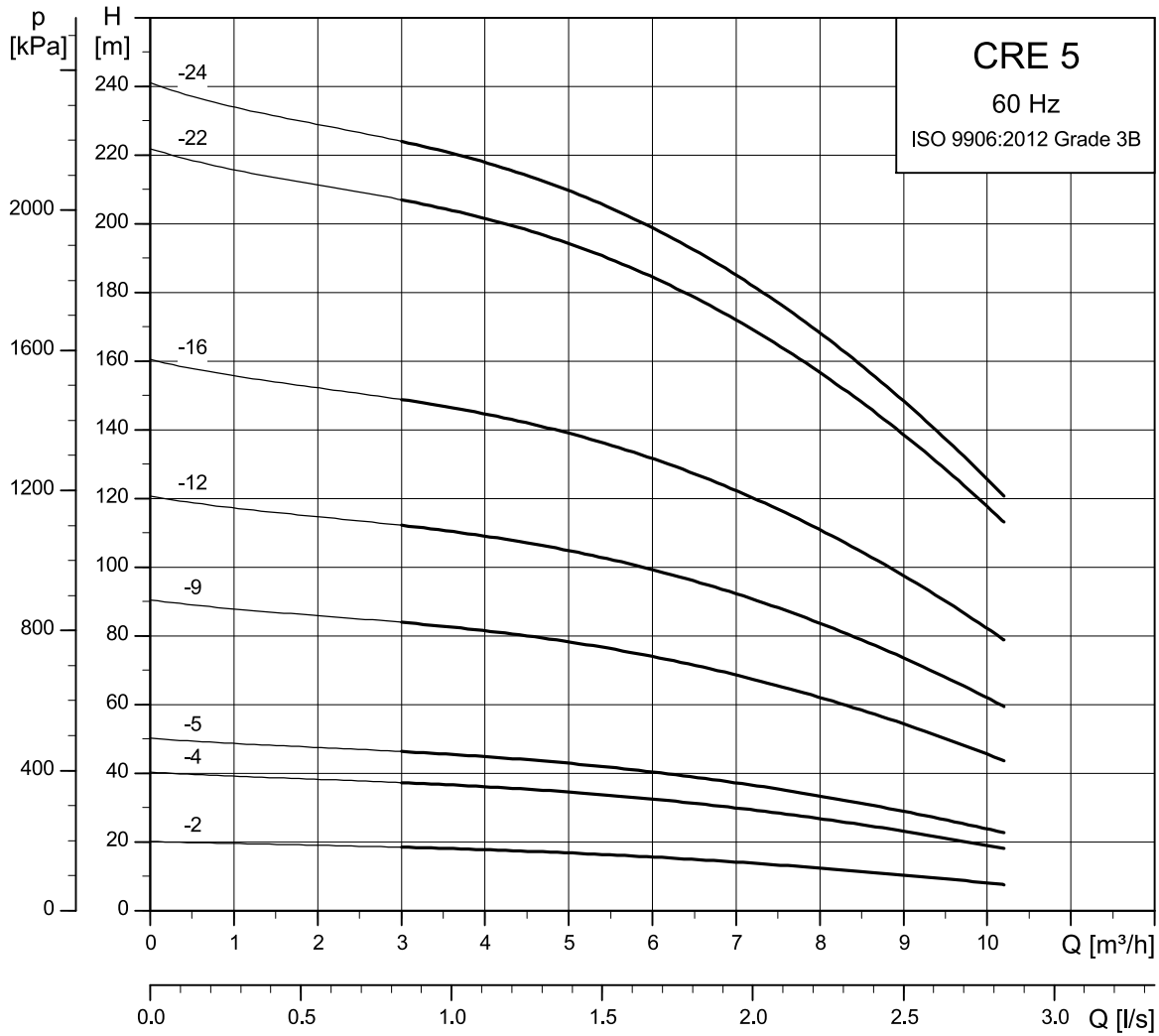

TM056837

Dimensional sketches

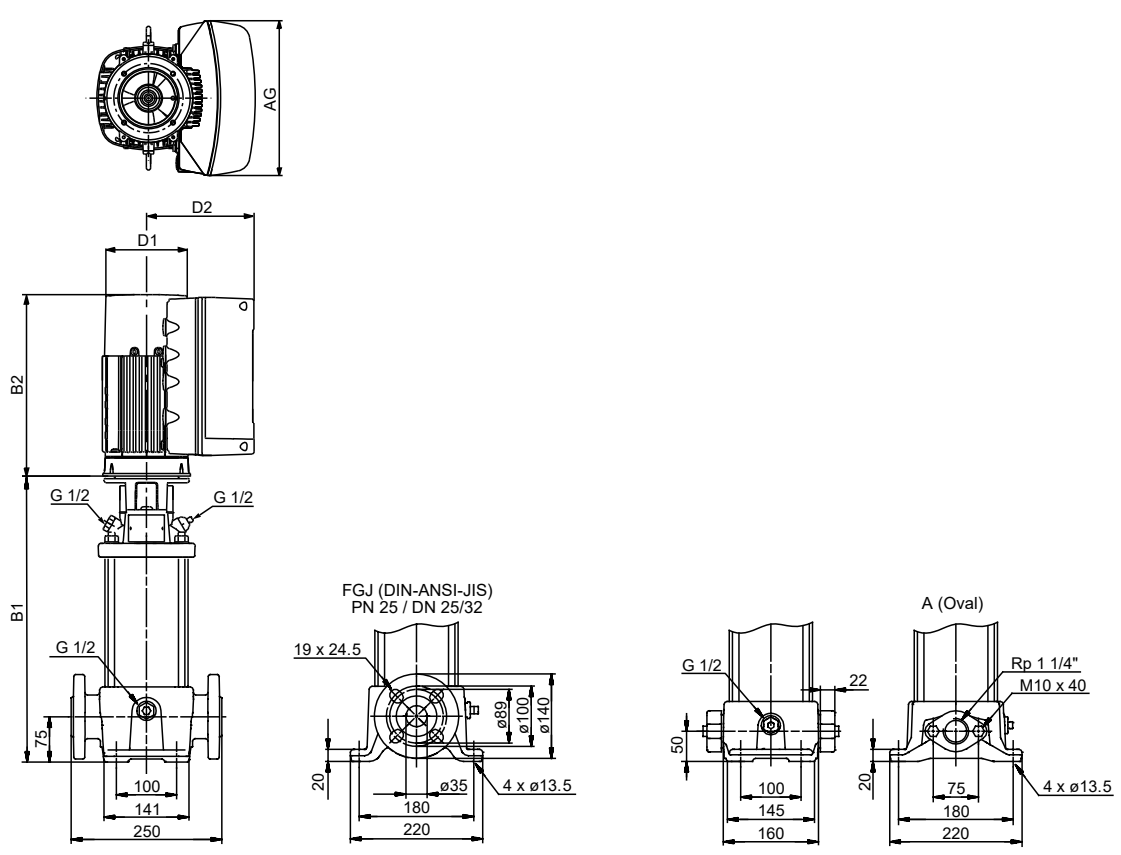

TM067709

Dimensions and weights

Pump type	P ₂ [kW]	CRE									
		Dimension [mm]				Net weight [kg]					
		Oval flange		DIN flange		D1	D2	D3	AG	Oval flange	DIN flange
B1	B1+B2	B1	B1+B2								
CRE 5-2	0.55	254	468	279	493	122	158	105	212	21	26
CRE 5-4	1.1	314	528	339	553	122	158	120	212	24	28
CRE 5-5	1.5	357	631	382	656	122	158	135	268	29	34
CRE 5-9	2.2	465	739	490	764	122	158	135	268	33	37
CRE 5-12	3	550	884	575	909	191.3	201	160	291	41	46
CRE 5-16	4	658	992	683	1017	191.3	201	160	291	51	56
CRE 5-22	5.5	-	-	875	1240	191.3	201	300	291	-	74
CRE 5-24	7.5	-	-	929	1318	255	237	300	346	-	81

Pumps fitted with single-phase MGE motors (0.37, 0.55, 0.75 or 1.1 kW) can as an option be fitted with three-phase MGE motors.

Pumps fitted with 1.5 kW three-phase MGE motors can as an option be fitted with single-phase MGE motors.

See Grundfos Product Center for dimensions.

CRIE, CRNE 5

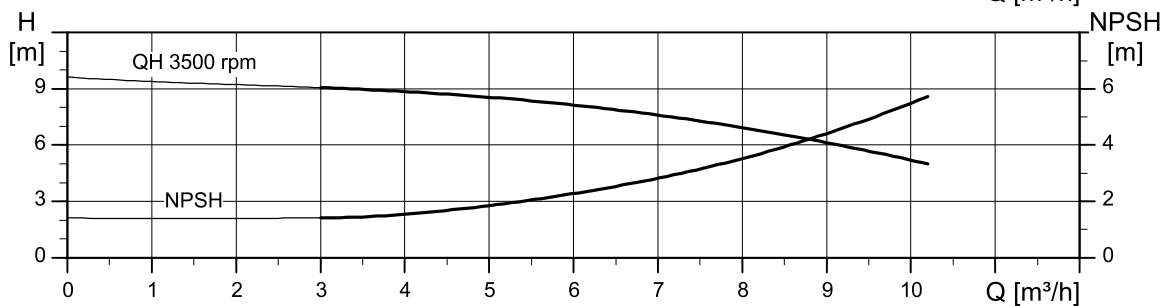
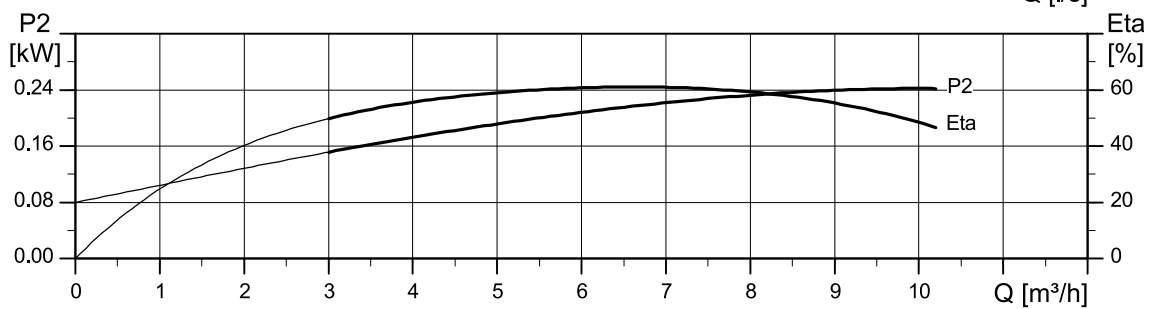
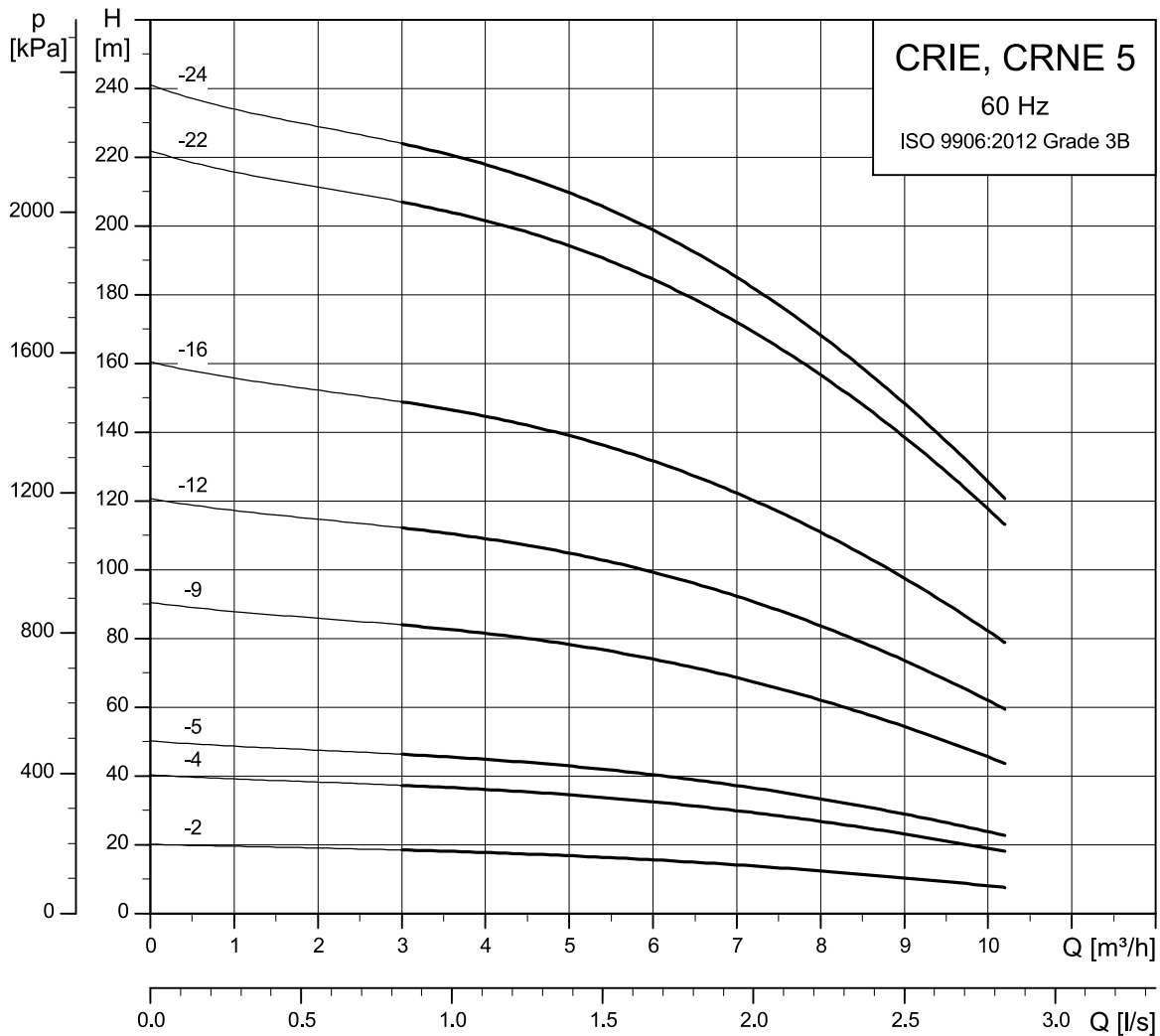

TM056838

Dimensional sketches

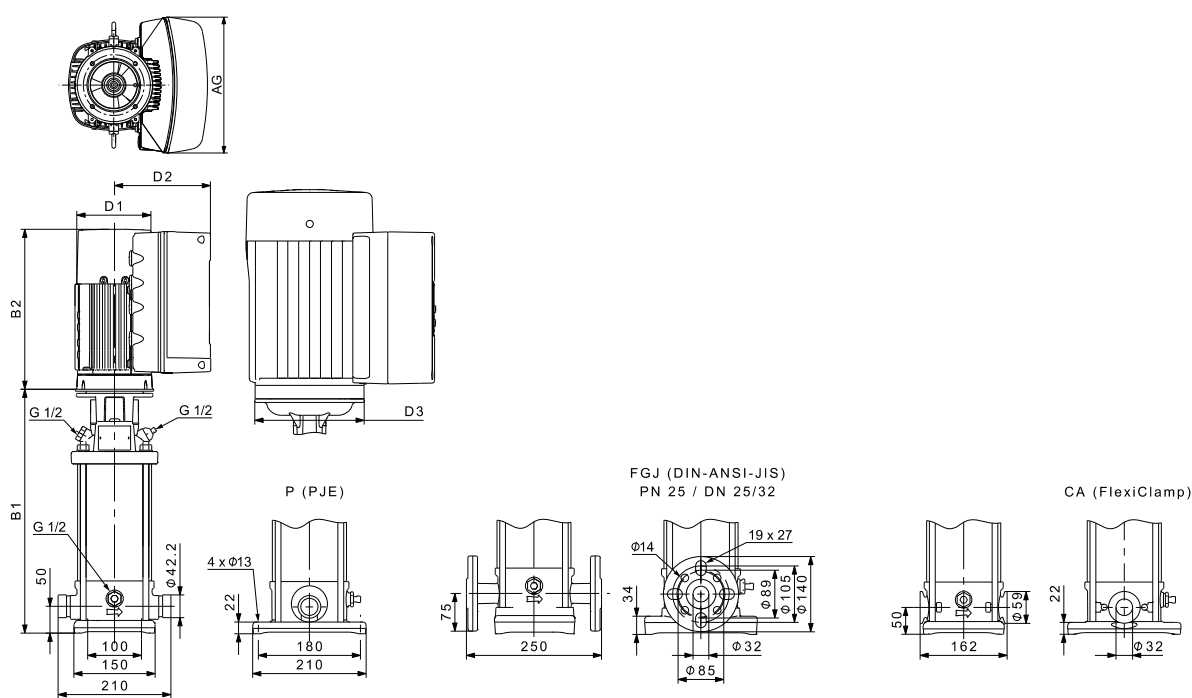

TM0569397

Dimensions and weights

Pump type	P ₂ [kW]	CRIE/CRNE									
		Dimension [mm]								Net weight [kg]	
		PJE/CA		DIN flange		D1	D2	D3	AG	PJE/CA	DIN flange
B1	B1+B2	B1	B1+B2								
CRIE, CRNE 5-2	0.55	257	471	282	496	122	158	105	212	19	23
CRIE, CRNE 5-4	1.1	317	531	342	556	122	158	120	212	23	27
CRIE, CRNE 5-5	1.5	360	634	385	659	122	158	135	268	27	31
CRIE, CRNE 5-9	2.2	468	742	493	767	122	158	135	268	31	35
CRIE, CRNE 5-12	3	554	888	579	913	191	201	160	291	40	44
CRIE, CRNE 5-16	4	662	996	687	1021	191	201	160	291	50	54
CRIE, CRNE 5-22	5.5	853	1218	878	1243	191	201	300	291	67	71
CRIE, CRNE 5-24	7.5	907	1296	932	1321	255	237	300	346	74	78

Pumps fitted with single-phase MGE motors (0.37, 0.55, 0.75 or 1.1 kW) can as an option be fitted with three-phase MGE motors.

Pumps fitted with 1.5 kW three-phase MGE motors can as an option be fitted with single-phase MGE motors.

See Grundfos Product Center for dimensions.

CRE 10

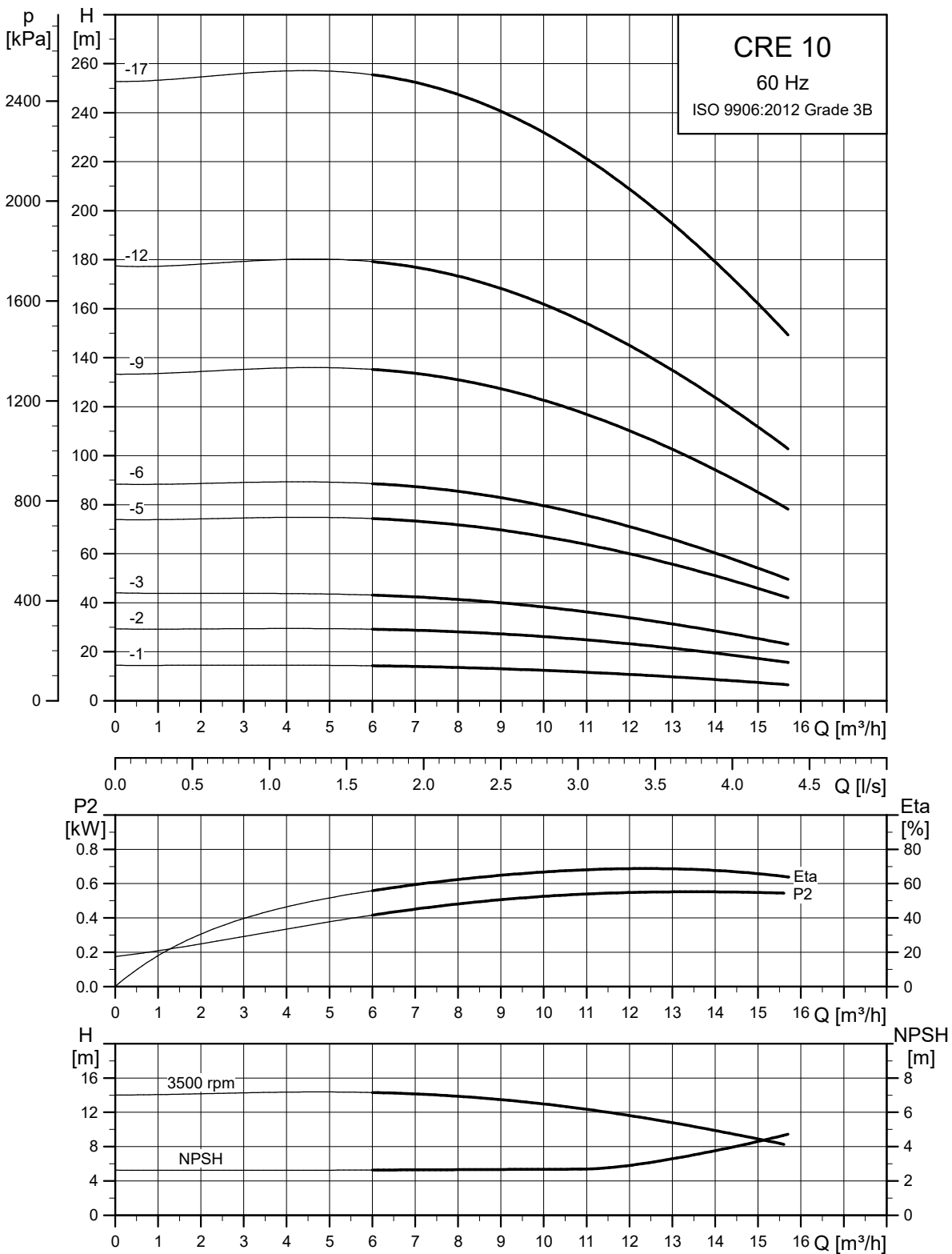

Performance curves and technical data

TM056839

Dimensional sketches

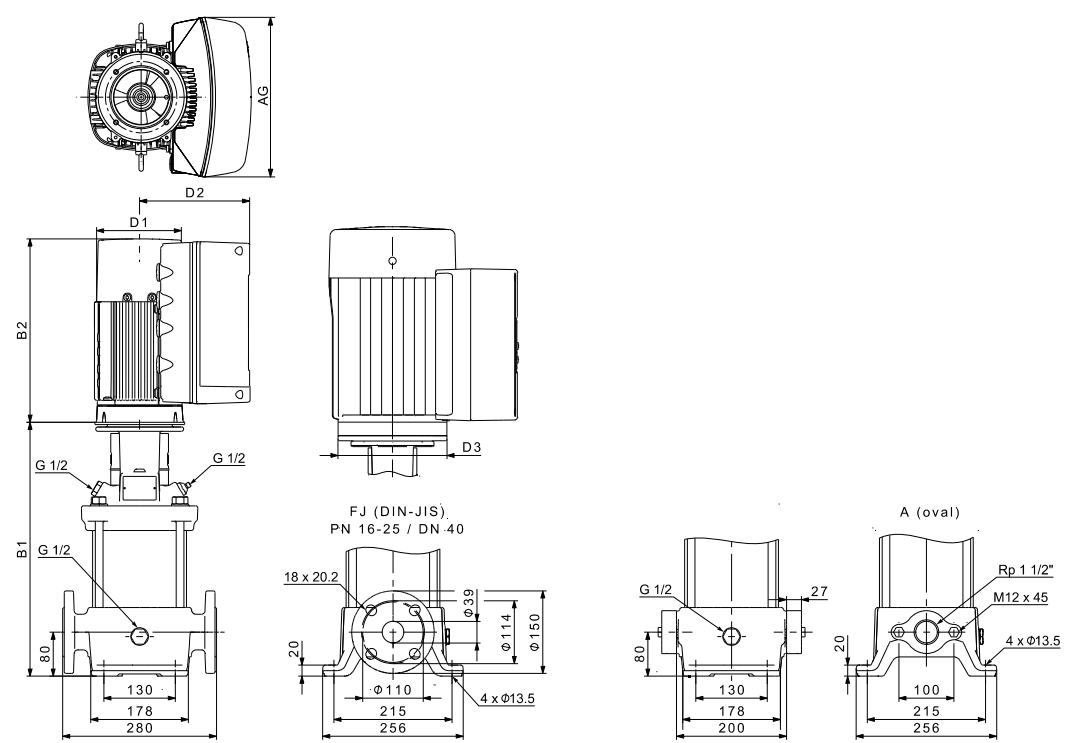

TM059398

Dimensions and weights

Pump type	P ₂ [kW]	CRE									
		Dimension [mm]						Net weight [kg]			
		Oval flange		DIN flange		D1	D2	D3	AG	Oval flange	DIN flange
B1	B1+B2	B1	B1+B2	Oval flange	DIN flange						
CRE 10-1	0.75	347	561	347	561	122	158	120	212	35	37
CRE 10-2	1.5	363	637	363	637	122	158	135	268	40	43
CRE 10-3	2.2	393	667	393	667	122	158	135	268	43	45
CRE 10-5	3	458	792	458	792	191	201	160	291	51	54
CRE 10-6	4	488	822	488	822	191	201	160	291	60	63
CRE 10-9	5.5	610	975	610	975	191	201	300	291	84	86
CRE 10-12	7.5	-	-	700	1089	255	237	300	346	-	95

Pumps fitted with single-phase MGE motors (0.37, 0.55, 0.75 or 1.1 kW) can as an option be fitted with three-phase MGE motors.
 Pumps fitted with 1.5 kW three-phase MGE motors can as an option be fitted with single-phase MGE motors.
 See Grundfos Product Center for dimensions.

CRIE, CRNE 10

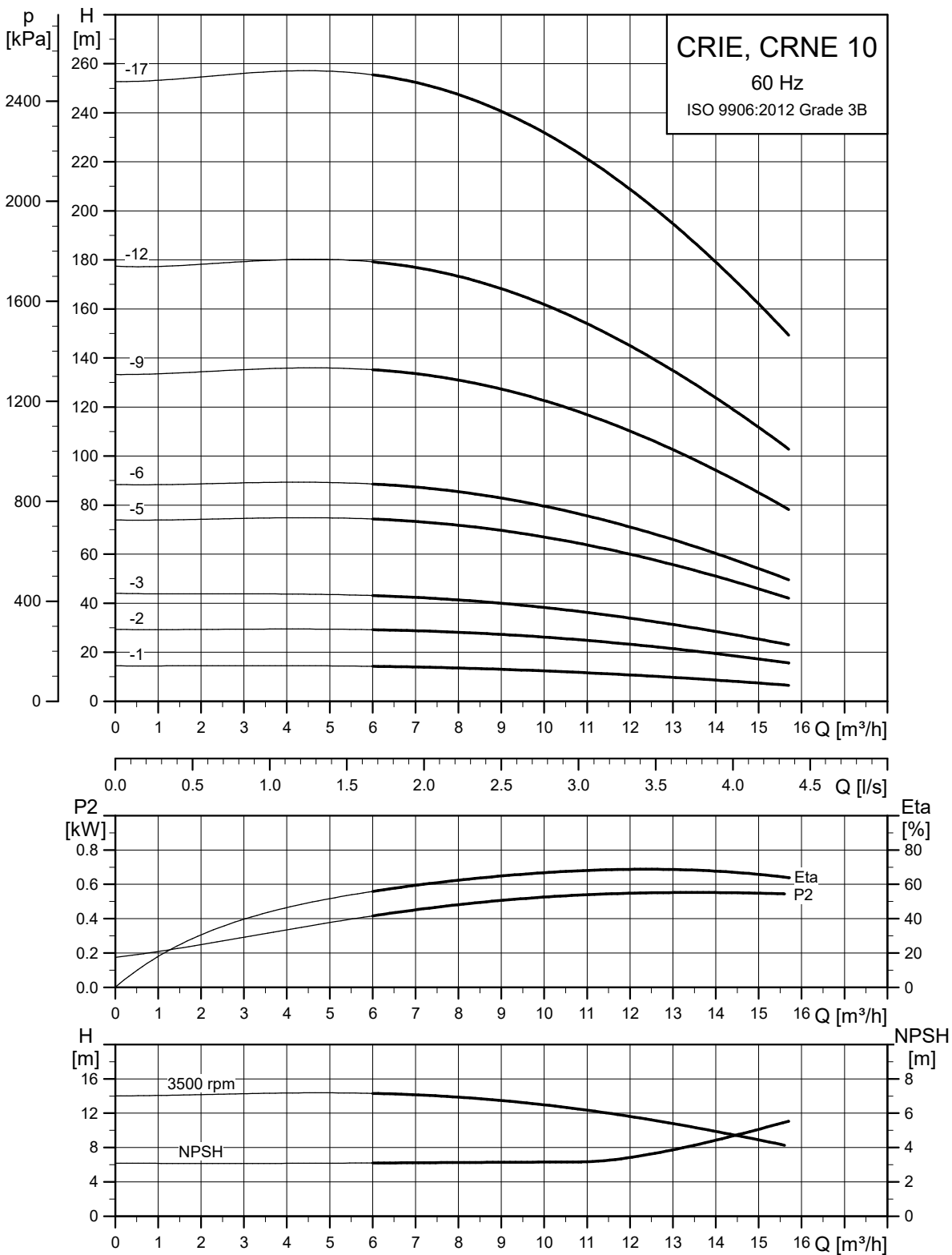

TM056840

Dimensional sketches

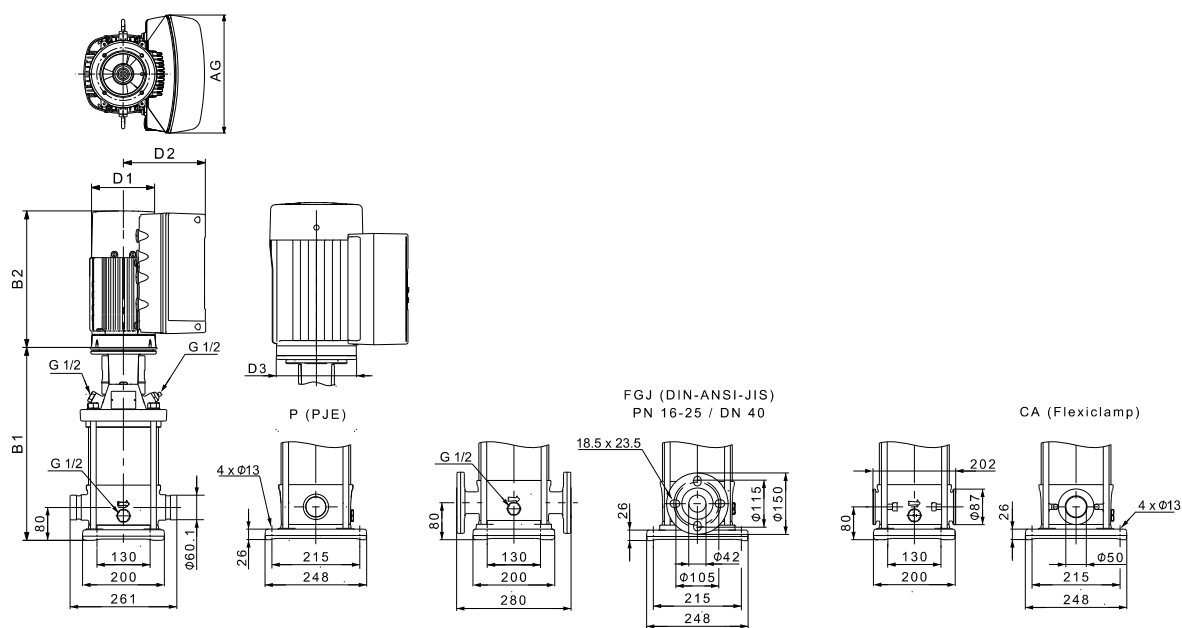

TM059401

Dimensions and weights

Pump type	P ₂ [kW]	CRIE/CRNE									
		Dimension [mm]								Net weight [kg]	
		PJE/CA		DIN flange		D1	D2	D3	AG	PJE/CA	DIN flange
B1	B1+B2	B1	B1+B2								
CRIE, CRNE 10-1	0.75	357	571	357	571	122	158	120	212	32	35
CRIE, CRNE 10-2	1.5	373	647	373	647	122	158	135	268	38	41
CRIE, CRNE 10-3	2.2	403	677	403	677	122	158	135	268	40	44
CRIE, CRNE 10-5	3	468	802	468	802	191	201	160	291	49	53
CRIE, CRNE 10-6	4	498	832	498	832	191	201	160	291	58	62
CRIE, CRNE 10-9	5.5	620	985	620	985	191	201	300	291	81	85
CRIE, CRNE 10-12	7.5	710	1099	710	1099	255	237	300	346	91	94

Pumps fitted with single-phase MGE motors (0.37, 0.55, 0.75 or 1.1 kW) can as an option be fitted with three-phase MGE motors.

Pumps fitted with 1.5 kW three-phase MGE motors can as an option be fitted with single-phase MGE motors.

See Grundfos Product Center for dimensions.

CRE 15

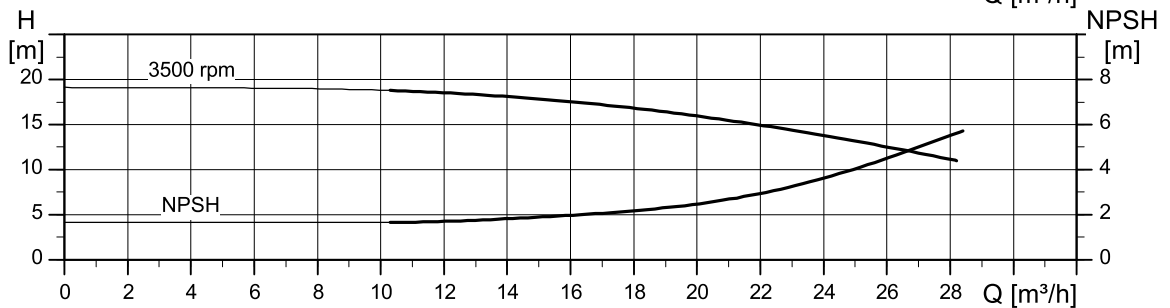
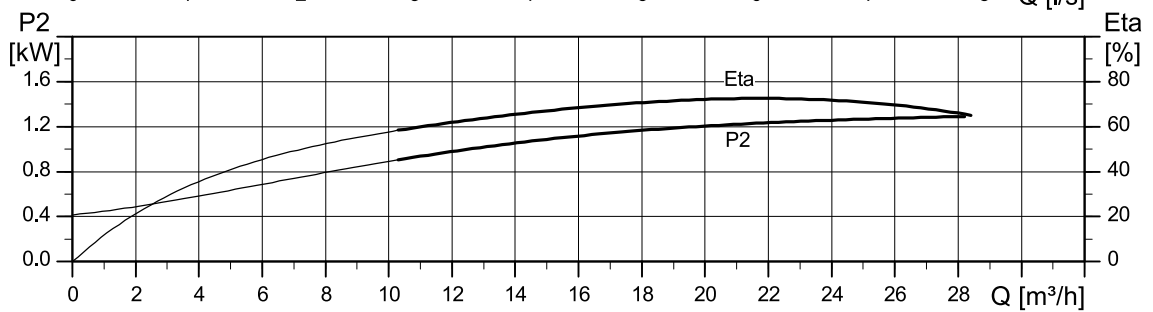
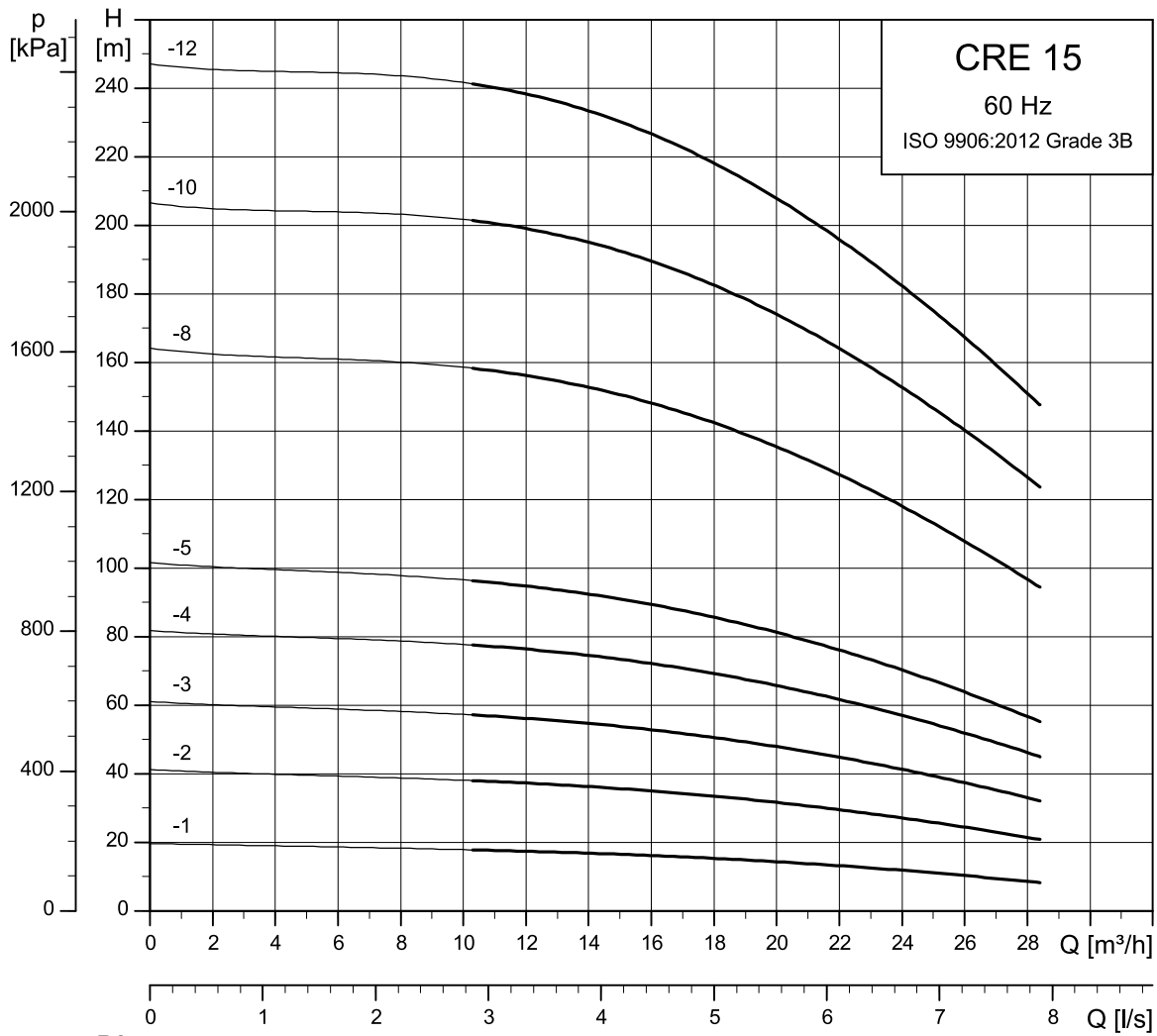

TM056841

Dimensional sketches

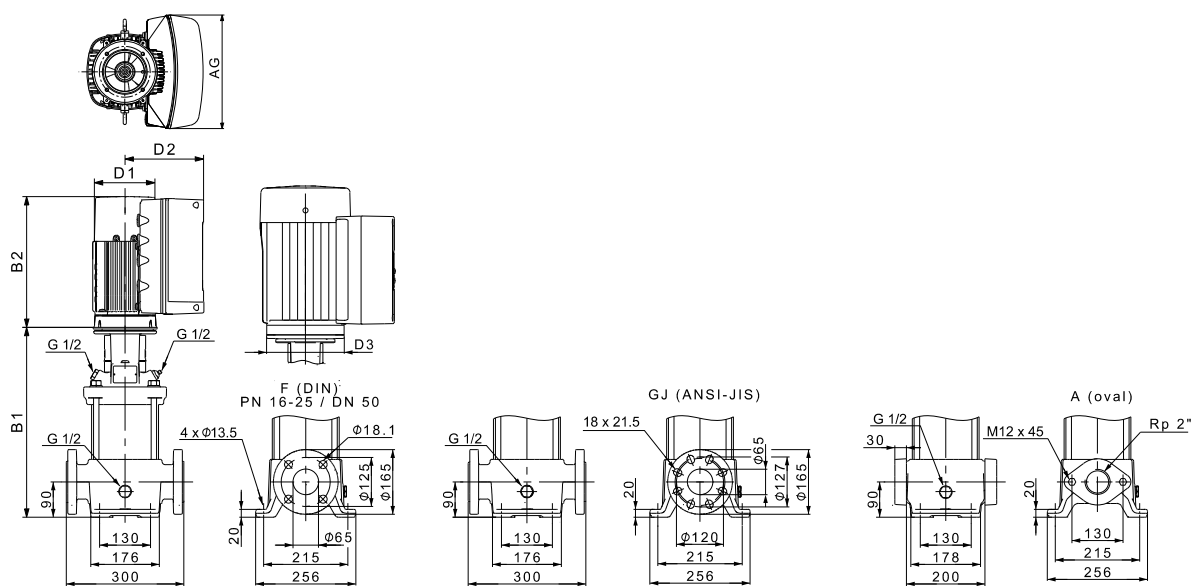

TM059399

Dimensions and weights

Pump type	P ₂ [kW]	CRE									
		Dimension [mm]								Net weight [kg]	
		Oval flange		DIN flange		D1	D2	D3	AG	Oval flange	DIN flange
		B1	B1+B2	B1	B1+B2						
CRE 15-1	1.5	415	689	415	689	122	158	135	268	46	47
CRE 15-2	3	420	754	420	754	191	201	160	291	54	55
CRE 15-3	4	465	799	465	799	191	201	160	291	63	64
CRE 15-4	5.5	542	907	542	907	191	201	300	291	85	86
CRE 15-5	7.5	587	976	587	976	255	237	300	346	93	93
CRE 15-8	11	-	-	799	1205	255	237	350	346	-	122
CRE 15-10	15	-	-	904	1386	318	303	350	420	-	160
CRE 15-12	18.5	-	-	994	1476	318	303	350	420	-	168

Pumps fitted with 1.5 kW three-phase MGE motors can as an option be fitted with single-phase MGE motors.
See Grundfos Product Center for dimensions.

CRIE, CRNE 15

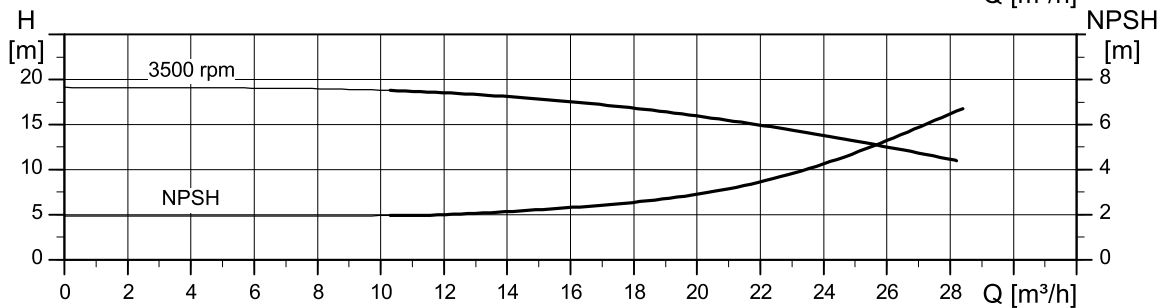
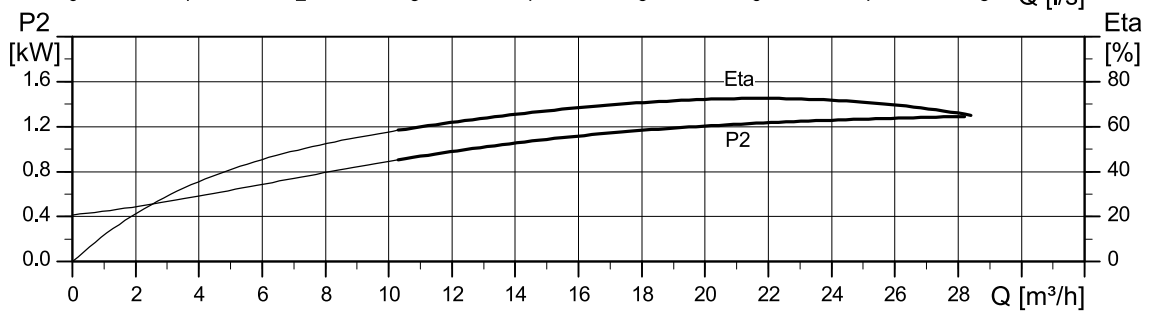
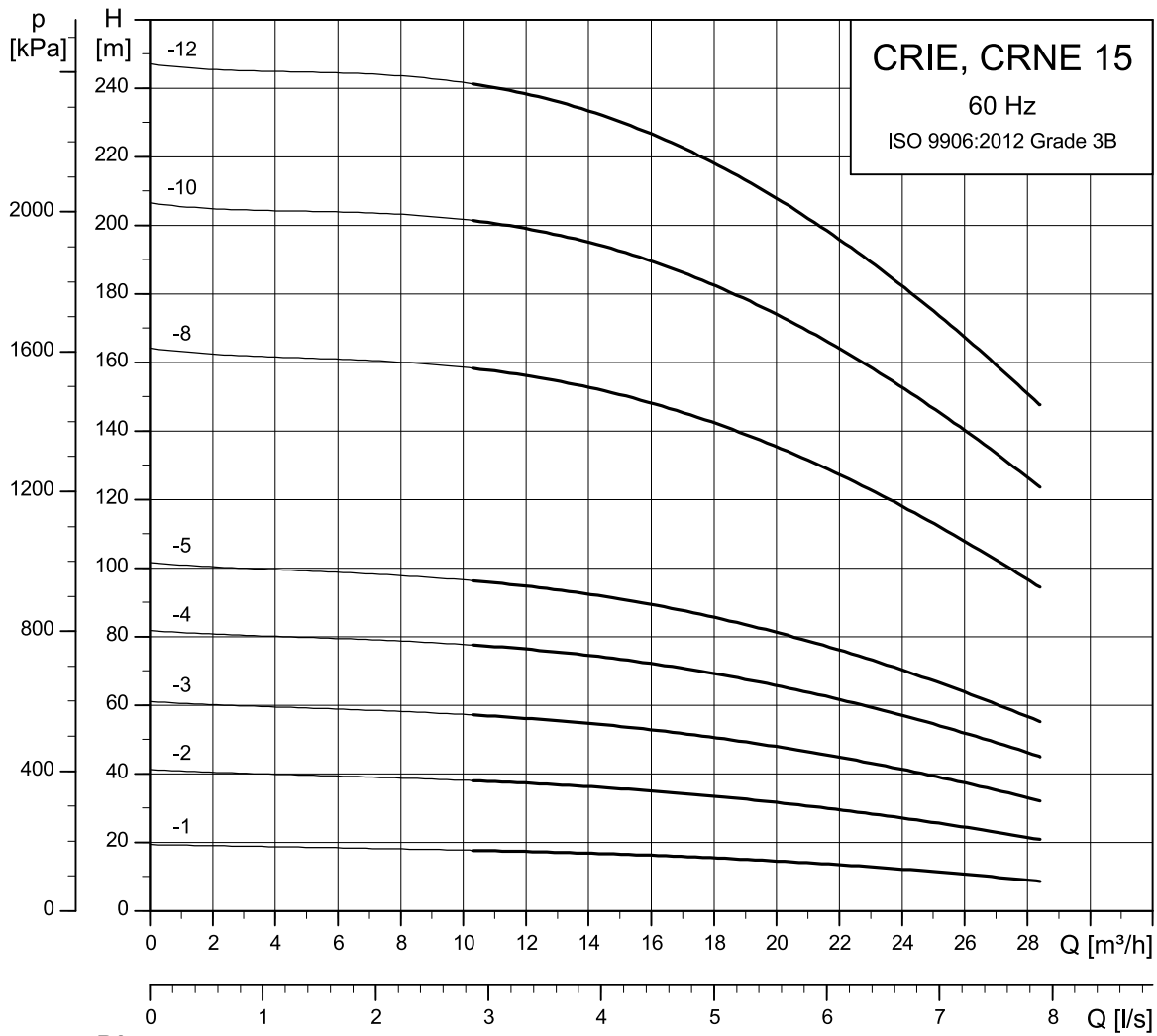

TM056842

Dimensional sketches

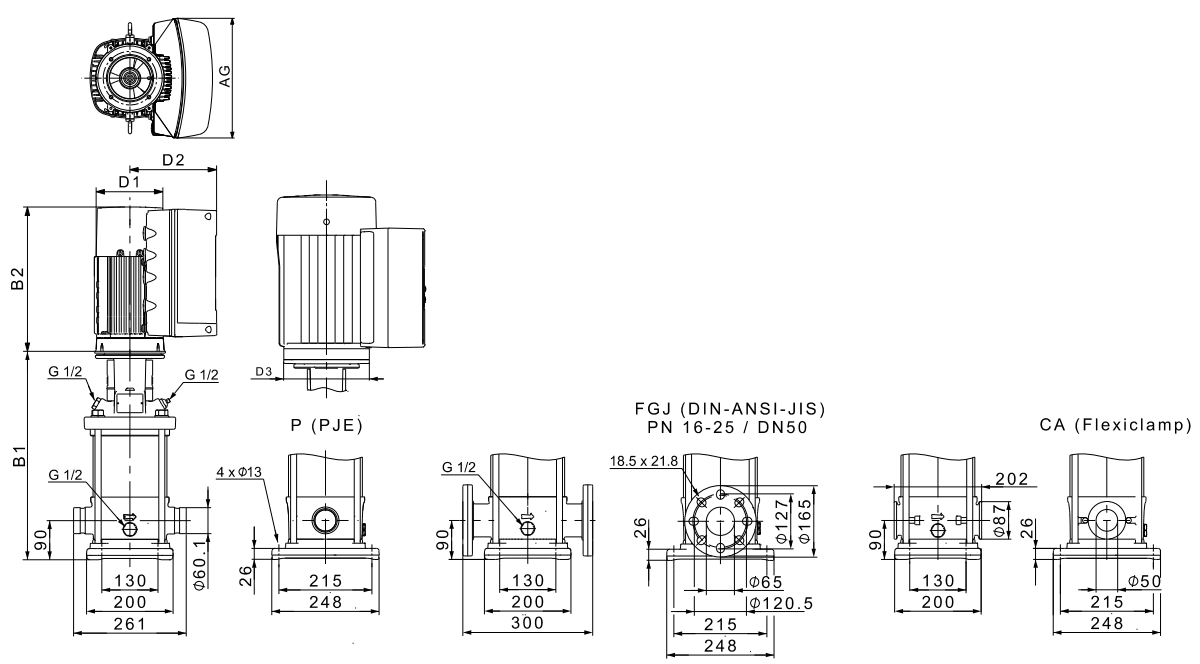

TM059400

Dimensions and weights

Pump type	P ₂ [kW]	CRIE/CRNE									
		Dimension [mm]								Net weight [kg]	
		PJE/CA		DIN flange		D1	D2	D3	AG	PJE/CA	DIN flange
		B1	B1+B2	B1	B1+B2						
CRIE, CRNE 15-1	1.5	413	687	413	687	122	158	135	268	39	43
CRIE, CRNE 15-2	3	418	752	418	752	191	201	160	291	48	52
CRIE, CRNE 15-3	4	463	797	463	797	191	201	160	291	57	61
CRIE, CRNE 15-4	5.5	540	905	540	905	191	201	300	291	78	83
CRIE, CRNE 15-5	7.5	585	974	585	974	255	237	300	346	86	91
CRIE, CRNE 15-8	11	797	1203	797	1203	255	237	350	346	115	120
CRIE, CRNE 15-10	15	902	1384	902	1384	318	303	350	420	152	157
CRIE, CRNE 15-12	18.5	992	1474	992	1474	318	303	350	420	160	165

Pumps fitted with 1.5 kW three-phase MGE motors can as an option be fitted with single-phase MGE motors.
See Grundfos Product Center for dimensions.

CRE 20

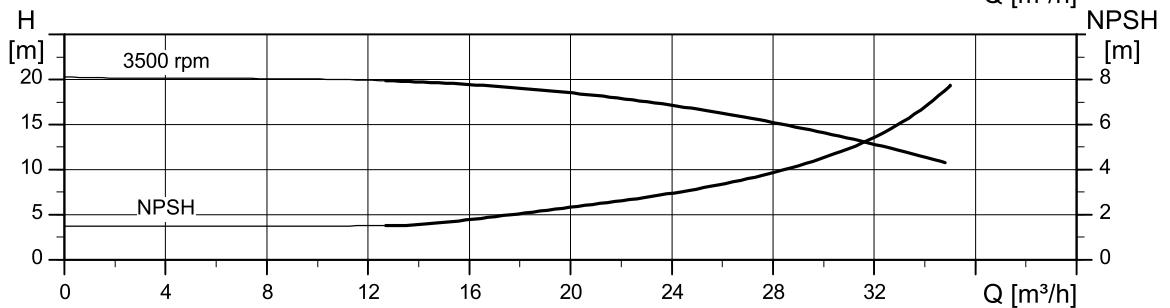
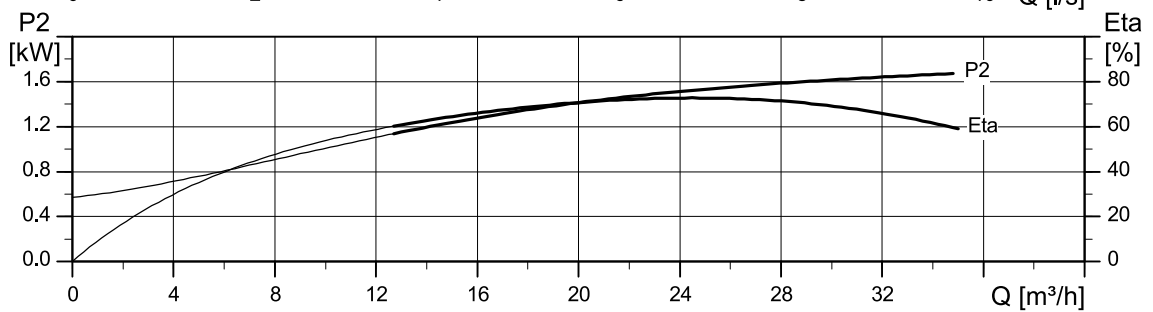
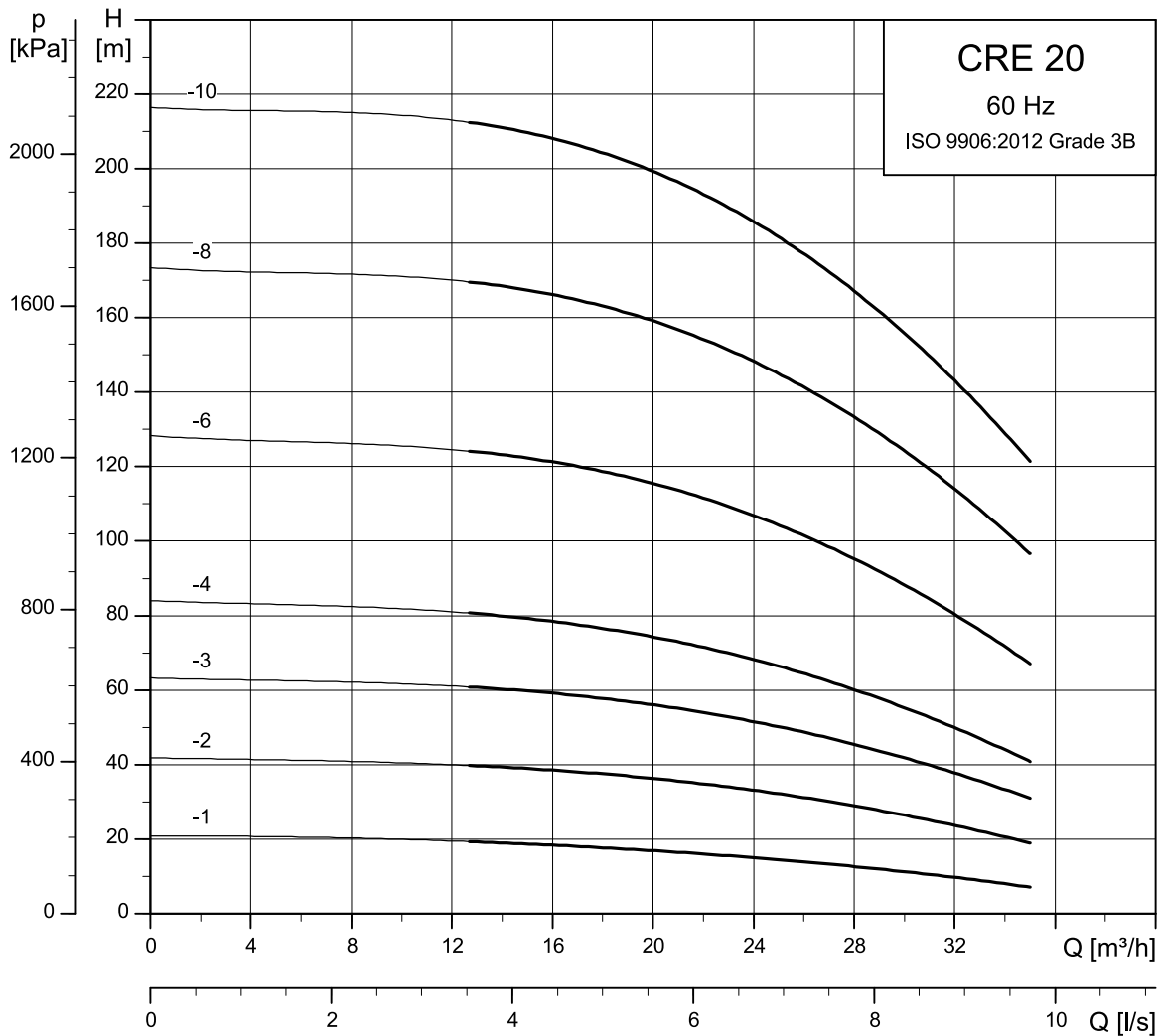

TM056843

Dimensional sketches

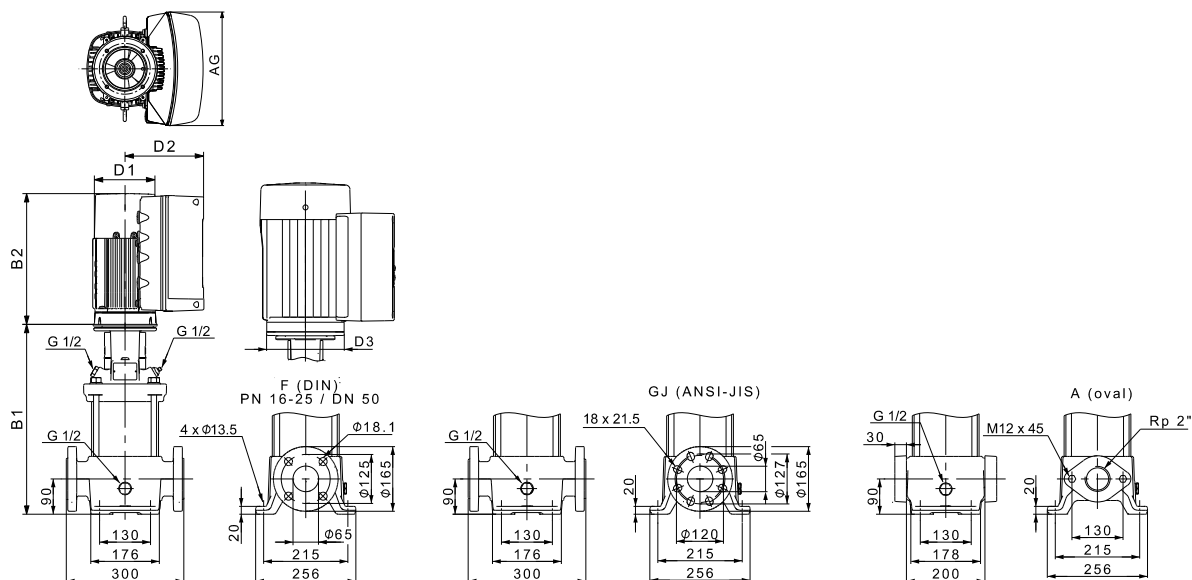

TM059399

Dimensions and weights

Pump type	P ₂ [kW]	CRE									
		Dimension [mm]								Net weight [kg]	
		Oval flange		DIN flange		D1	D2	D3	AG	Oval flange	DIN flange
		B1	B1+B2	B1	B1+B2						
CRE 20-1	2.2	415	689	415	689	122	158	135	268	47	48
CRE 20-2	4	420	754	420	754	191	201	160	291	62	63
CRE 20-3	5.5	497	862	497	862	191	201	300	291	84	84
CRE 20-4	7.5	542	931	542	931	255	237	300	346	91	92
CRE 20-6	11	-	-	724	1130	255	237	350	346	-	132
CRE 20-8	15	-	-	814	1296	318	303	350	420	-	157
CRE 20-10	18.5	-	-	904	1386	318	303	350	420	-	165

CRIE, CRNE 20

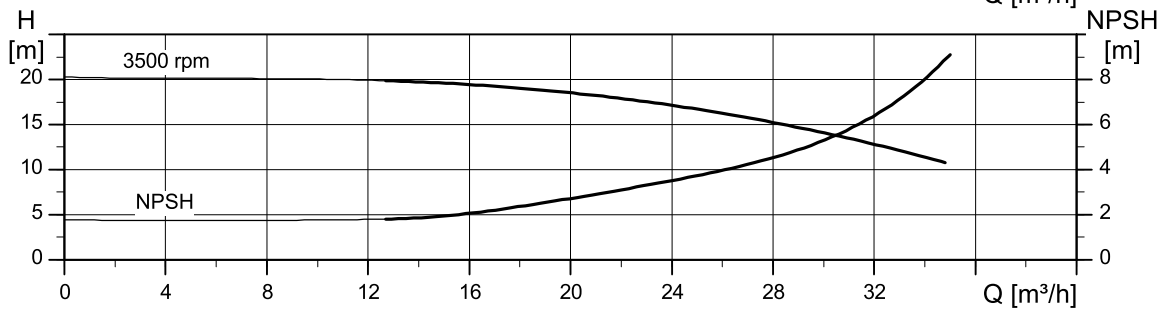
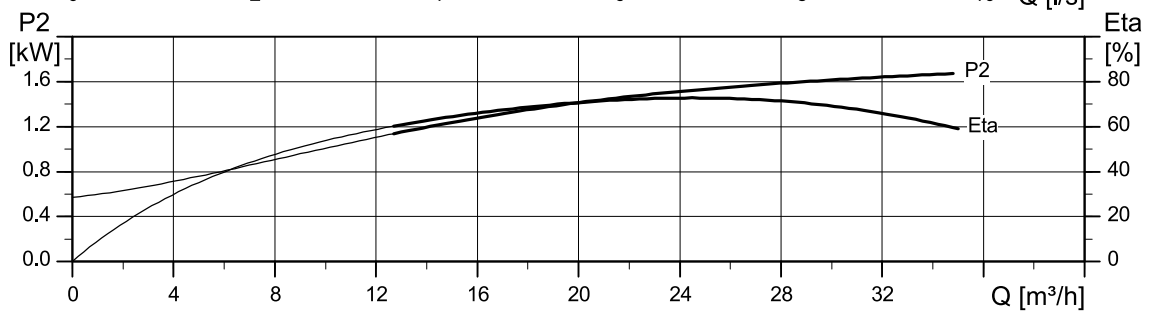
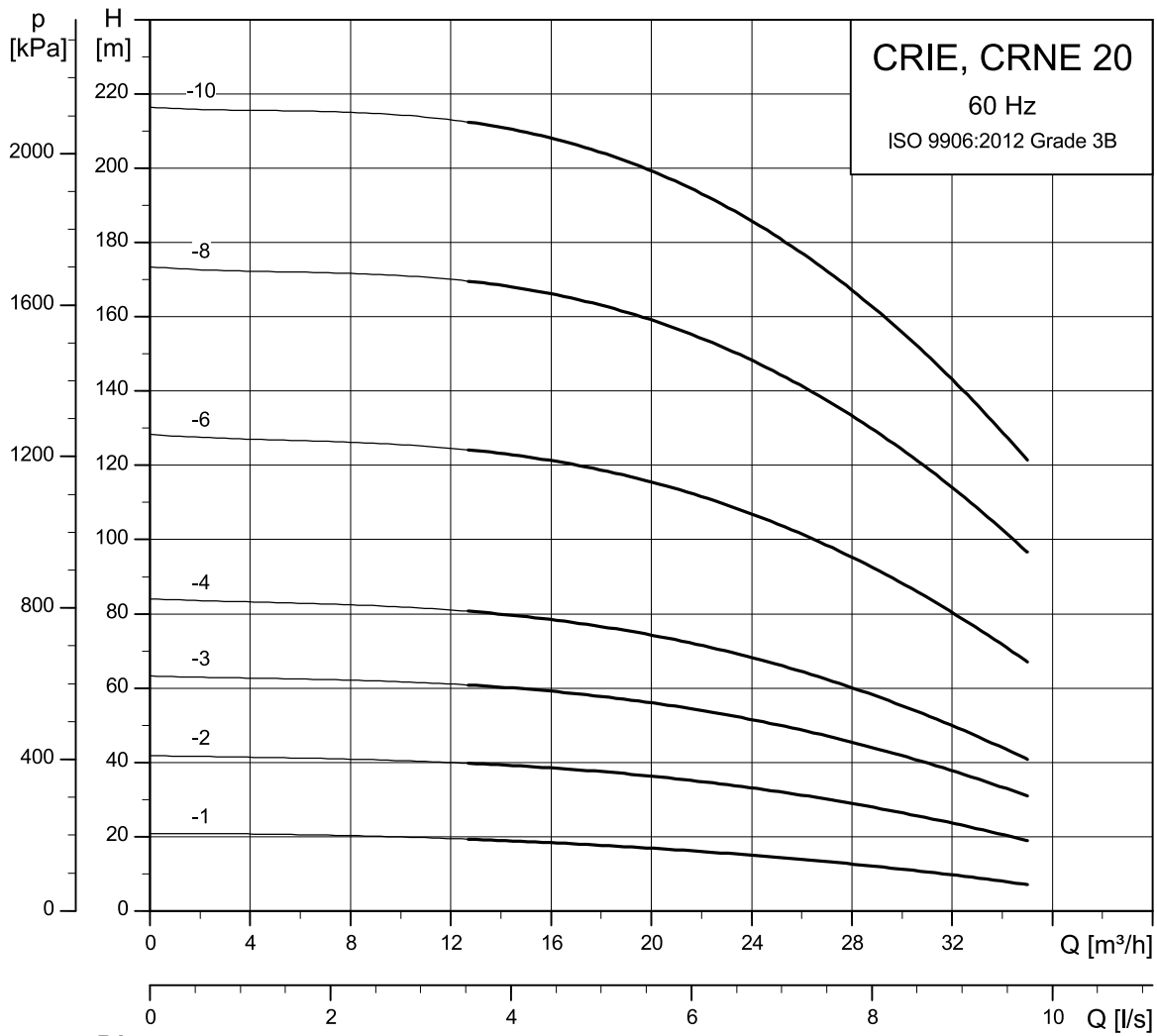

TM056844

Dimensional sketches

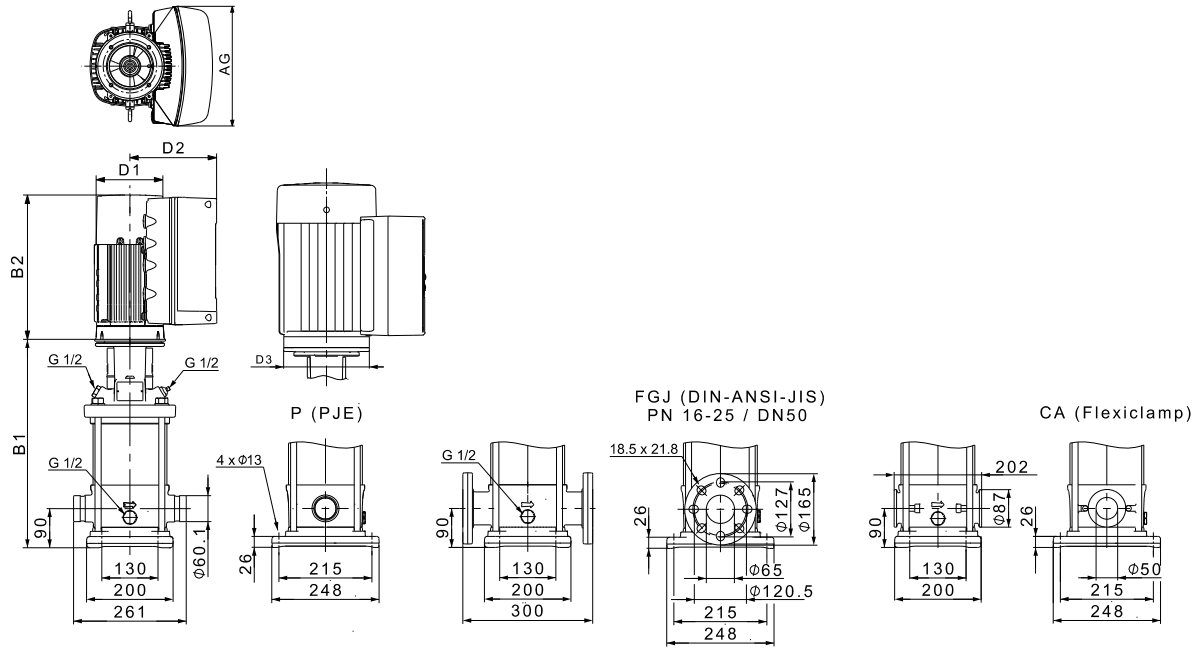

TM059400

Dimensions and weights

Pump type	P ₂ [kW]	CRIE/CRNE									
		Dimension [mm]								Net weight [kg]	
		PJE/CA		DIN flange		D1	D2	D3	AG	PJE/CA	DIN flange
		B1	B1+B2	B1	B1+B2						
CRIE, CRNE 20-1	2.2	413	687	413	687	122	158	135	268	40	45
CRIE, CRNE 20-2	4	418	752	418	752	191	201	160	291	55	60
CRIE, CRNE 20-3	5.5	495	860	495	860	191	201	300	291	77	82
CRIE, CRNE 20-4	7.5	540	929	540	929	255	237	300	346	85	89
CRIE, CRNE 20-6	11	722	1128	722	1128	255	237	350	346	125	130
CRIE, CRNE 20-8	15	812	1294	812	1294	318	303	350	420	149	153
CRIE, CRNE 20-10	18.5	902	1384	902	1384	318	303	350	420	157	161

CRE 32

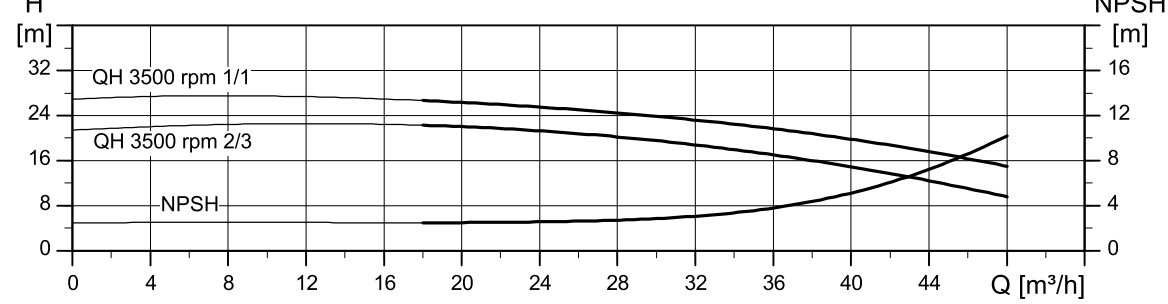
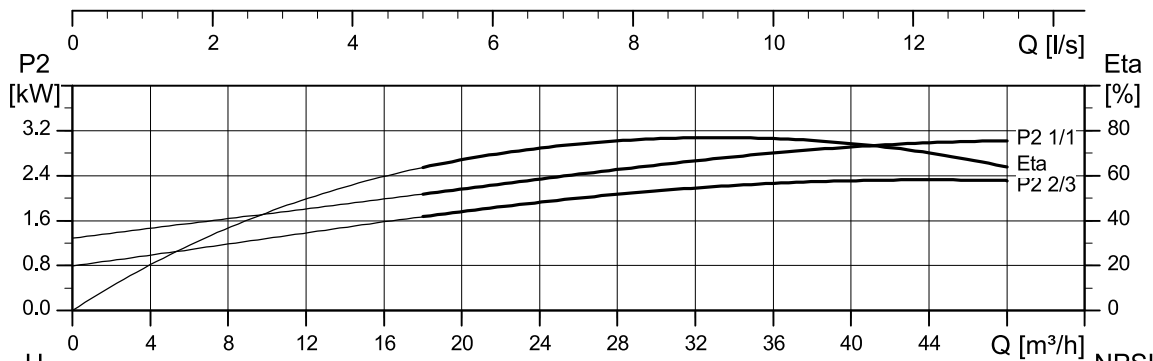
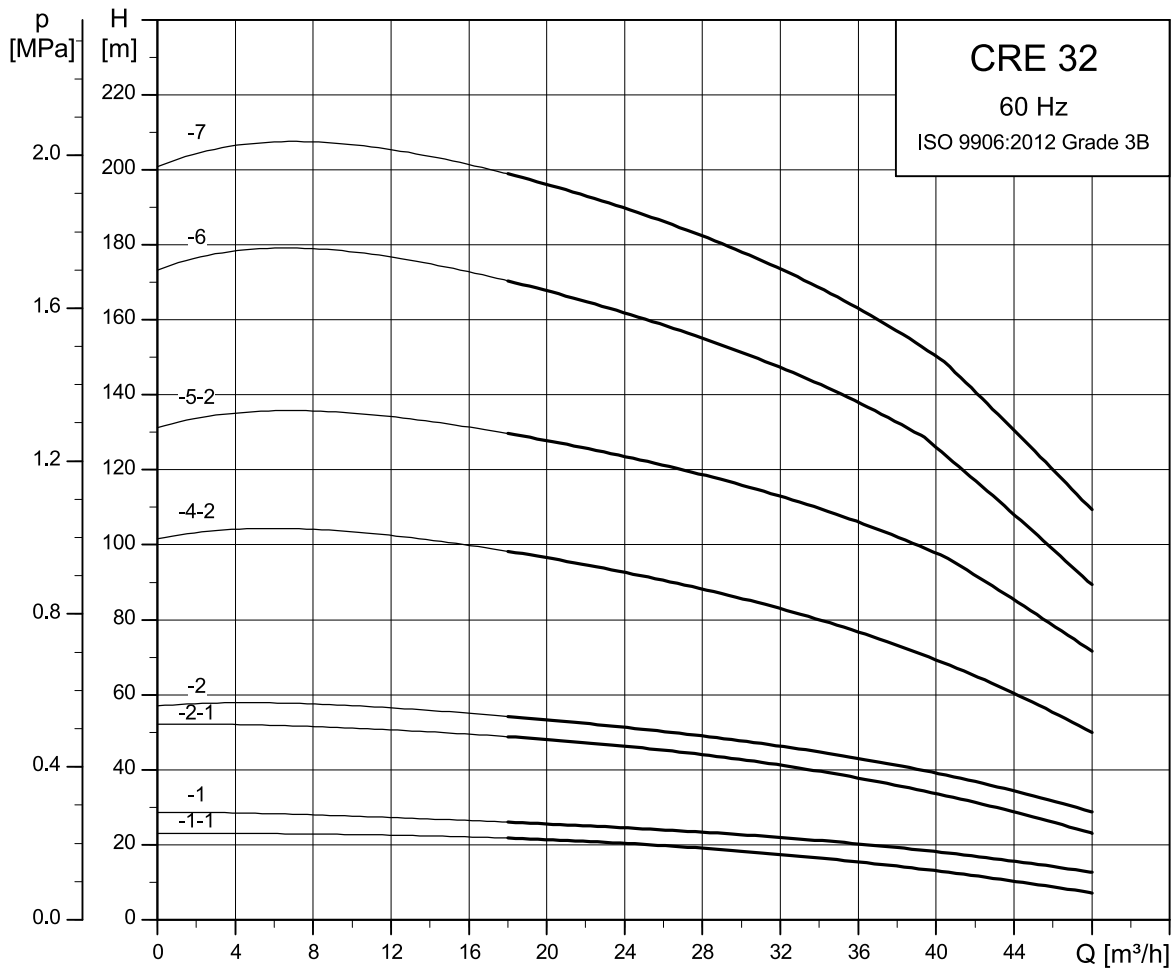

TM056845

Dimensional sketches

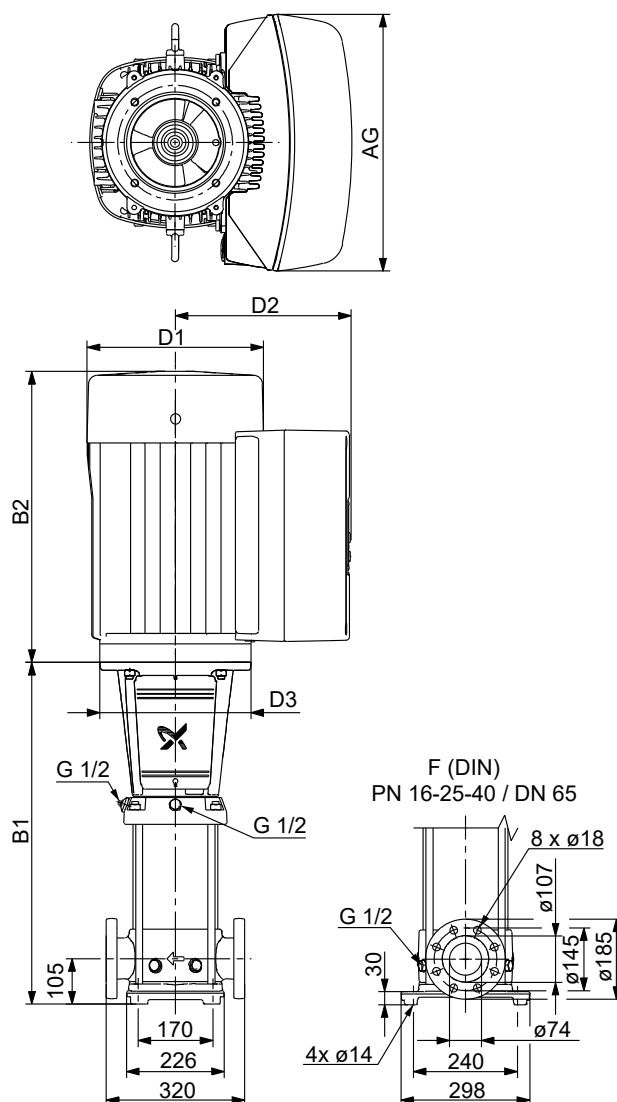

TM059384

Dimensions and weights

Pump type	P ₂ [kW]	CRE						Net weight [kg]
		Dimension [mm]						
		B1	B1+B2	D1	D2	D3	AG	
CRE 32-1-1	2.2	505	779	122	158	135	268	63
CRE 32-1	3	505	839	191	201	160	291	69
CRE 32-2-1	5.5	575	940	191	201	300	291	91
CRE 32-2	7.5	575	964	255	237	300	346	97
CRE 32-4-2	11	825	1231	255	237	350	346	129
CRE 32-5-2	15	895	1377	318	303	350	420	153
CRE 32-6	18.5	965	1447	318	303	350	420	160
CRE 32-7	22	1035	1543	318	303	350	420	177

CRNE 32

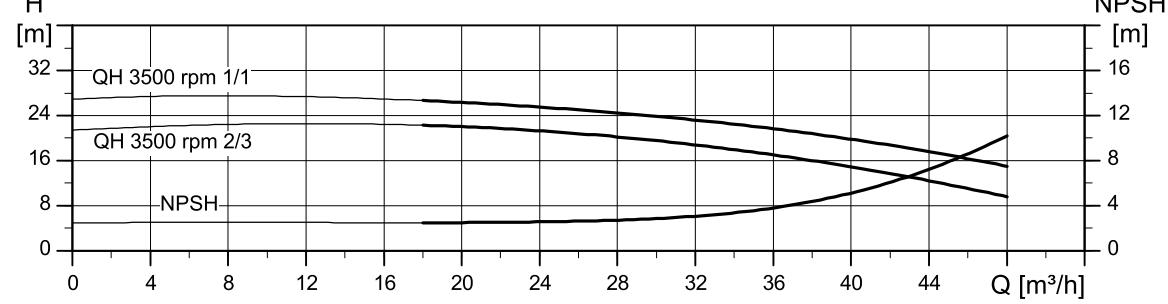
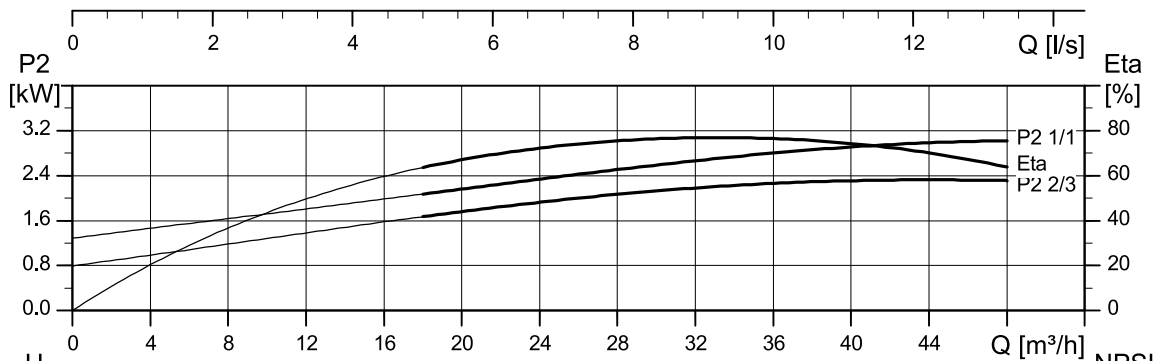
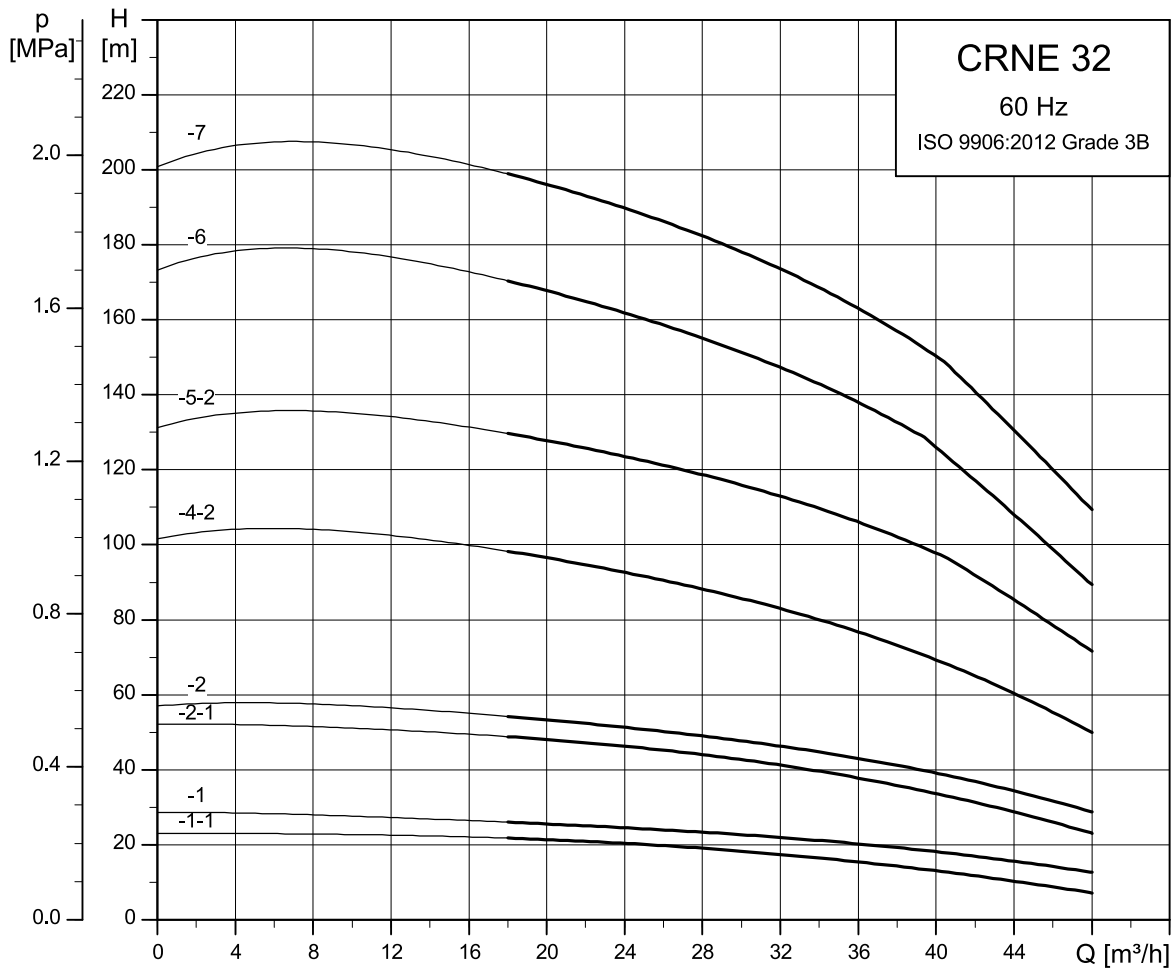

TM056846

Dimensional sketches

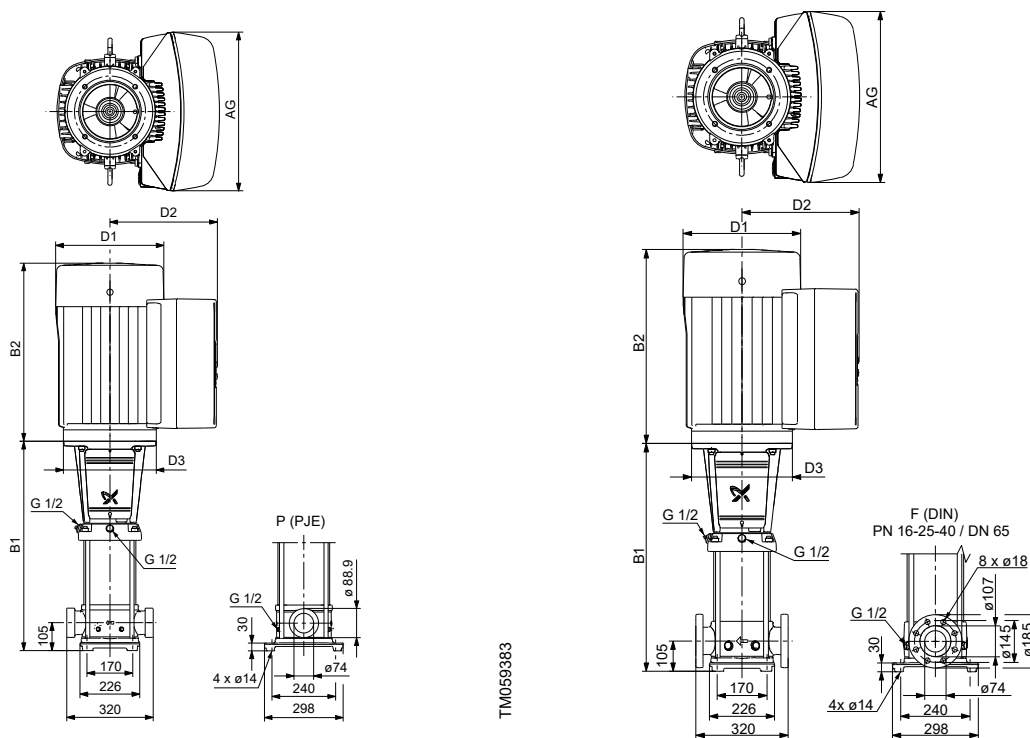

Dimensions and weights

Pump type	P ₂ [kW]	CRNE									
		Dimension [mm]								Net weight [kg]	
		PJE		DIN flange		D1	D2	D3	AG	PJE/CA	DIN flange
		B1	B1+B2	B1	B1+B2						
CRNE 32-1-1	2.2	505	779	505	779	122	158	135	268	65	65
CRNE 32-1	3	505	839	505	839	191	201	160	291	71	71
CRNE 32-2-1	5.5	575	940	575	940	191	201	300	291	93	93
CRNE 32-2	7.5	575	964	575	964	255	237	300	346	99	99
CRNE 32-4-2	11	825	1231	825	1231	255	237	350	346	132	132
CRNE 32-5-2	15	895	1377	895	1377	318	303	350	420	155	155
CRNE 32-6	18.5	965	1447	965	1447	318	303	350	420	162	162
CRNE 32-7	22	1035	1543	1035	1543	318	303	350	420	179	179

CRE 45

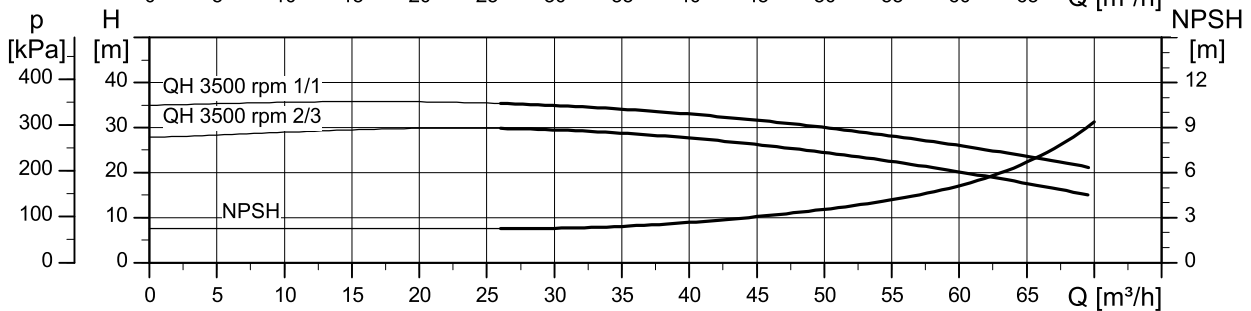
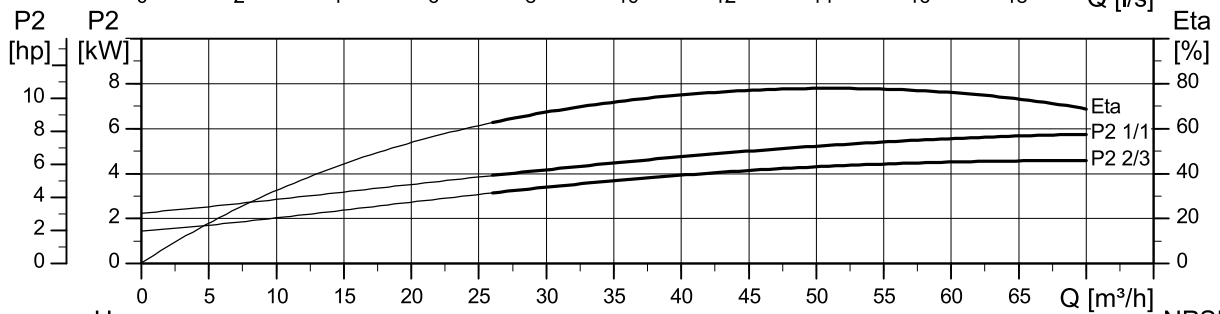
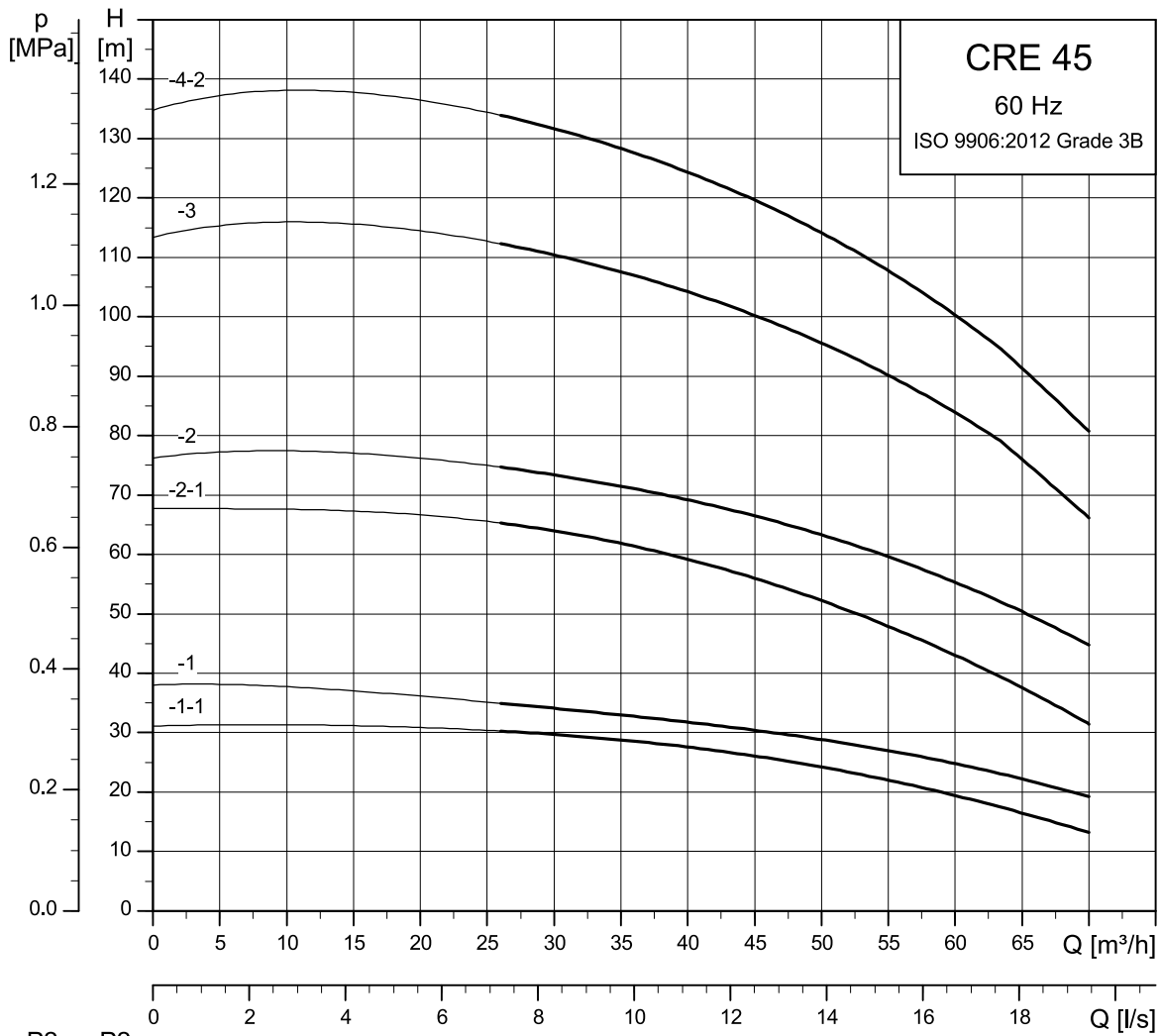

TM056847

Dimensional sketches

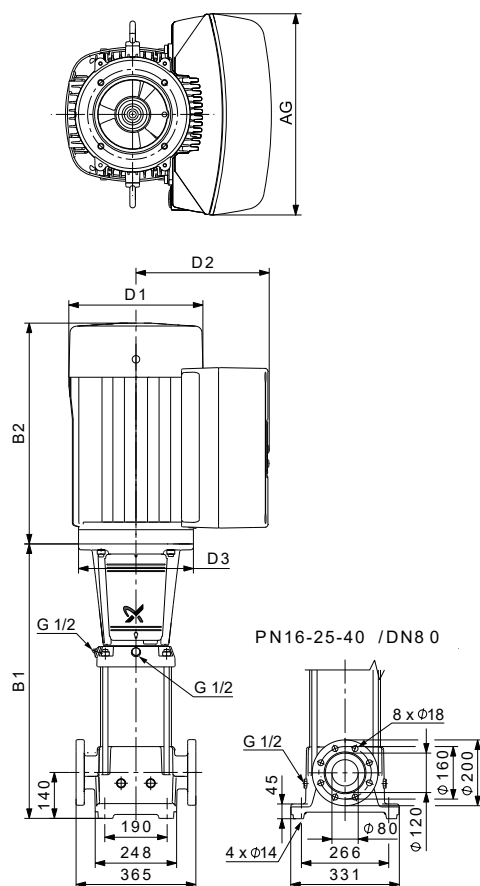

TM059385

Dimensions and weights

Pump type	P ₂ [kW]	CRE						Net weight [kg]
		Dimension [mm]						
		B1	B1+B2	D1	D2	D3	AG	
CRE 45-1-1	5.5	559	924	191	201	300	291	98
CRE 45-1	7.5	559	948	255	237	300	346	104
CRE 45-2-2	11	749	1155	255	237	350	346	134
CRE 45-2-1	11	749	1155	255	237	350	346	134
CRE 45-2	15	749	1231	318	303	350	420	154
CRE 45-3	18.5	829	1311	318	303	350	420	162
CRE 45-4-2	22	909	1417	318	303	350	420	180

CRNE 45

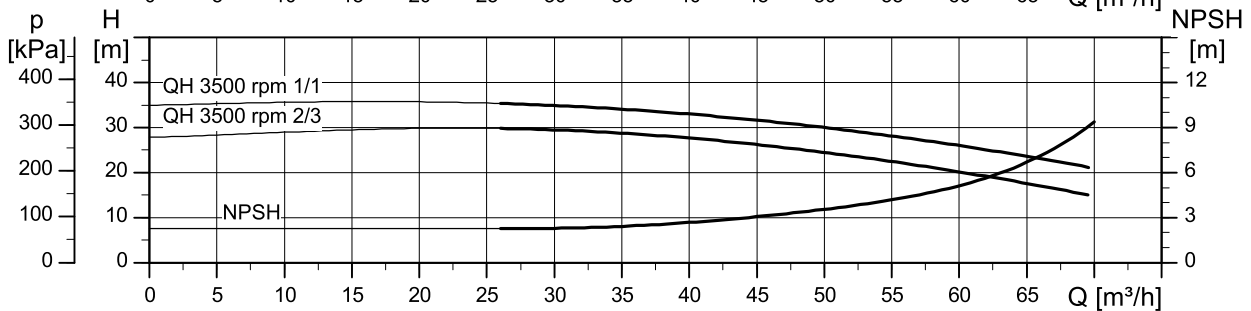
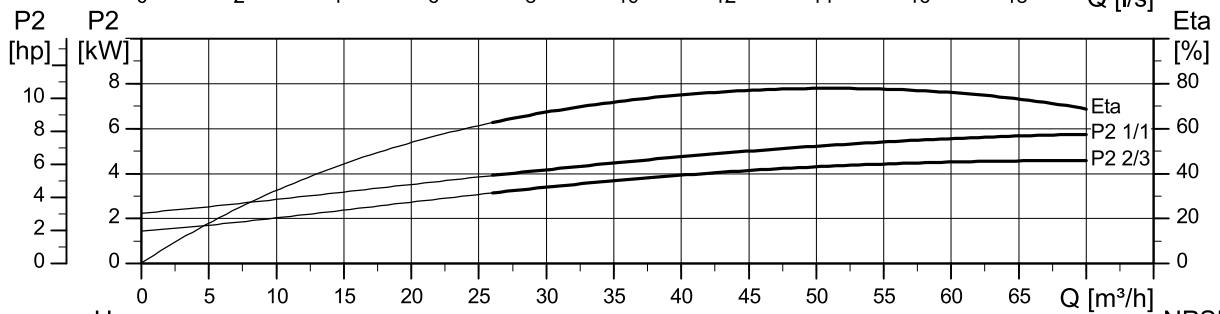
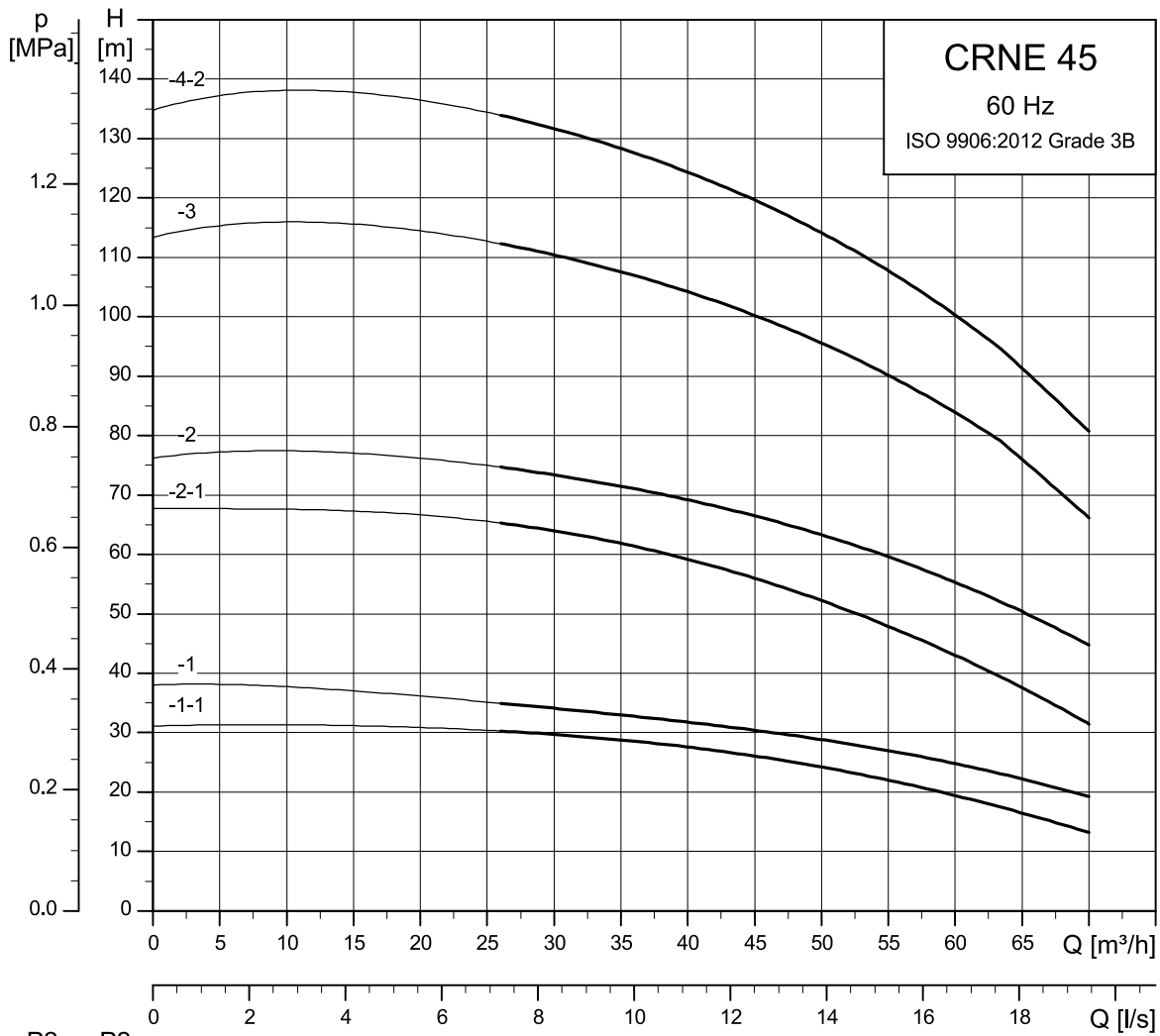

TM056848

Dimensional sketches

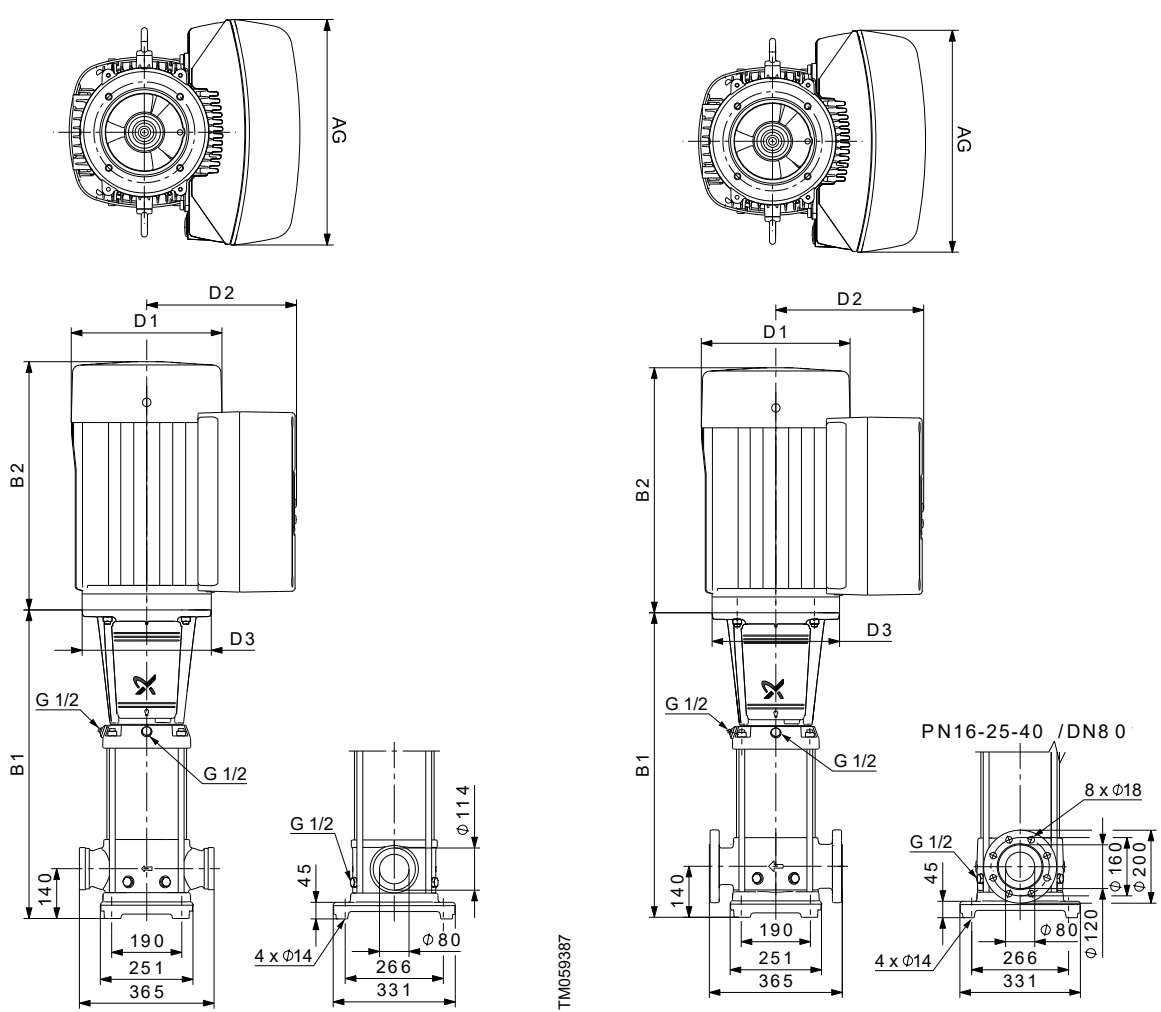

Dimensions and weights

Pump type	P ₂ [kW]	CRNE									
		Dimension [mm]								Net weight [kg]	
		PJE		DIN flange		D1	D2	D3	AG	PJE/CA	DIN flange
		B1	B1+B2	B1	B1+B2						
CRNE 45-1-1	5.5	559	924	559	924	191	201	300	291	98	98
CRNE 45-1	7.5	559	948	559	948	255	237	300	346	104	104
CRNE 45-2-2	11	749	1155	749	1155	255	237	350	346	134	134
CRNE 45-2-1	11	749	1155	749	1155	255	237	350	346	134	134
CRNE 45-2	15	749	1231	749	1231	318	303	350	420	154	154
CRNE 45-3	18.5	829	1311	829	1311	318	303	350	420	163	163
CRNE 45-4-2	22	909	1417	909	1417	318	303	350	420	180	180

CRE 64

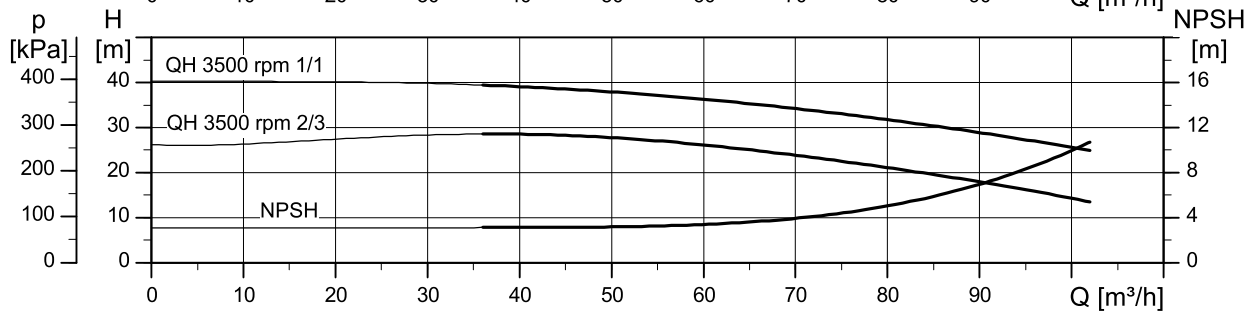
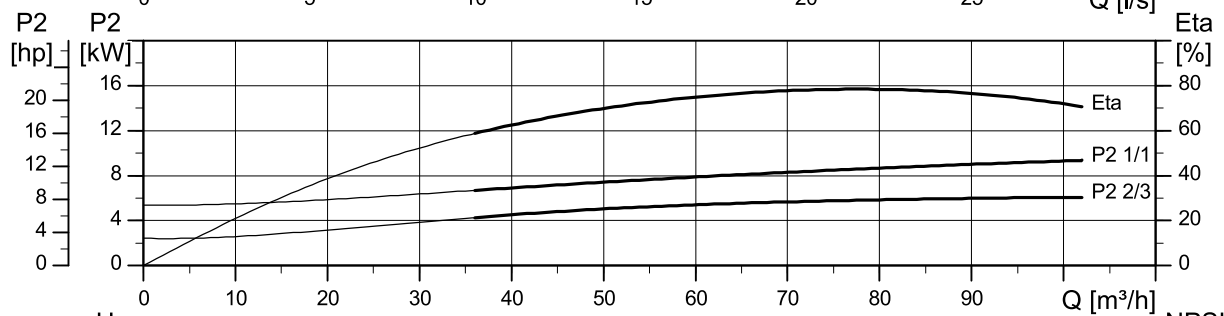
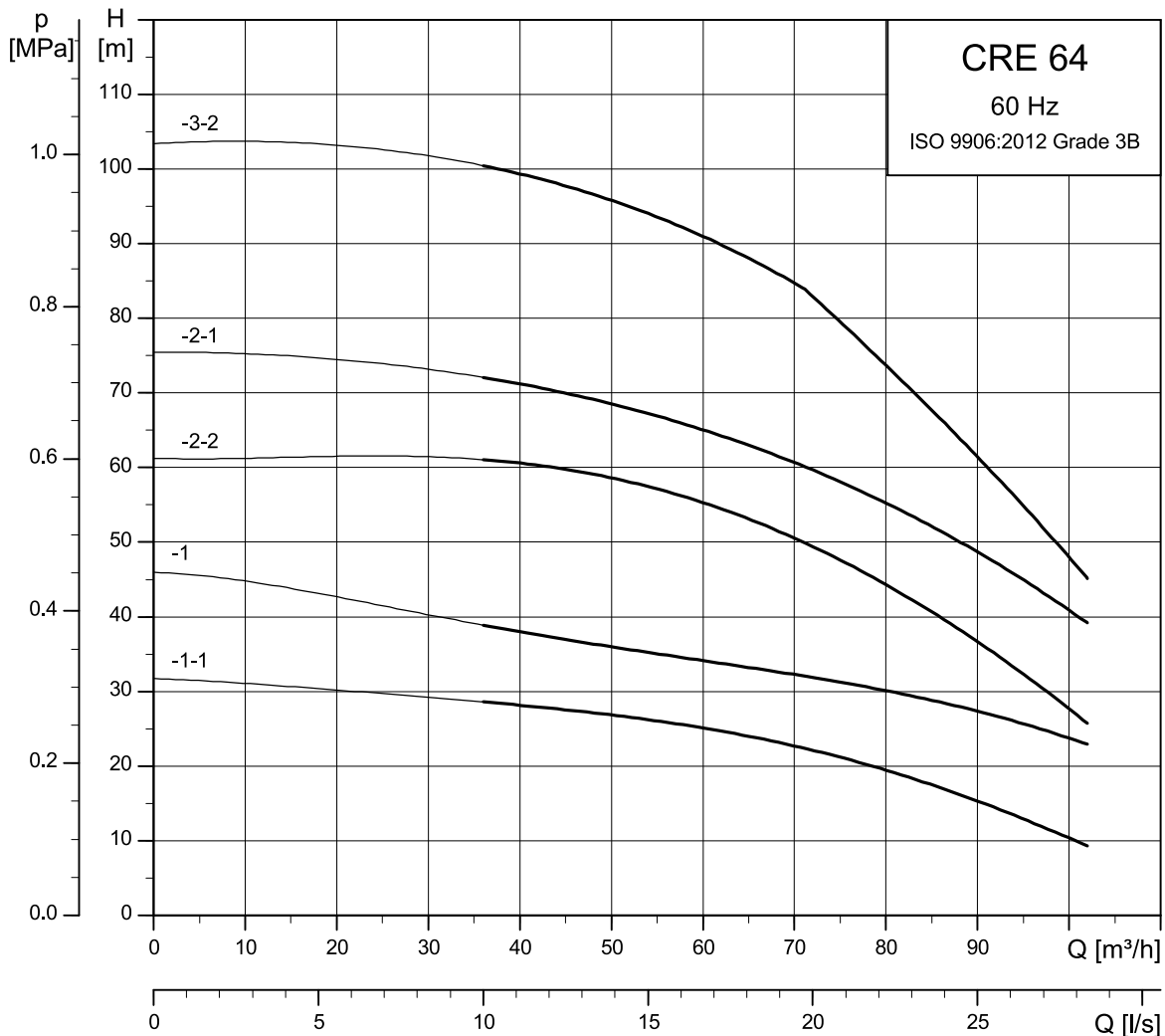

TM056849

Dimensional sketches

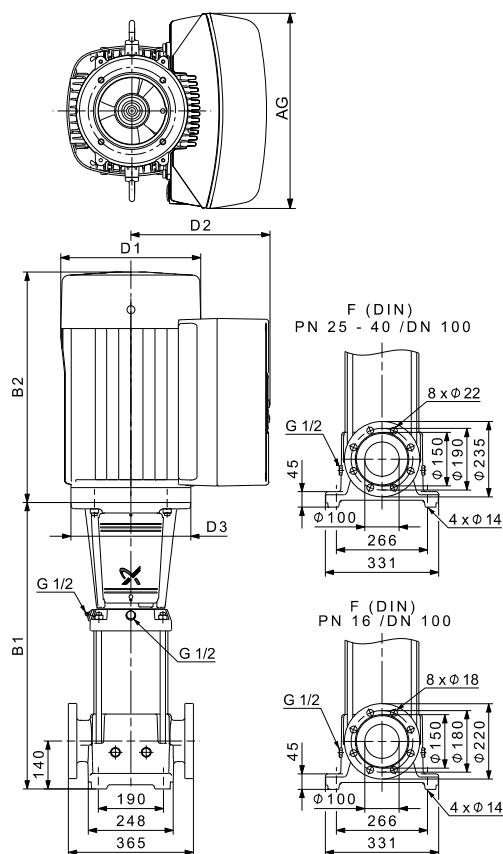

TM059388

Dimensions and weights

Pump type	P ₂ [kW]	CRE						Net weight [kg]
		Dimension [mm]						
		B1	B1+B2	D1	D2	D3	AG	
CRE 64-1-1	7.5	561	950	255	237	300	346	106
CRE 64-1	11	671	1077	255	237	350	346	132
CRE 64-2-2	15	754	1236	318	303	350	420	157
CRE 64-2-1	18.5	754	1236	318	303	350	420	162
CRE 64-3-2	22	836	1344	318	303	350	420	180

CRNE 64

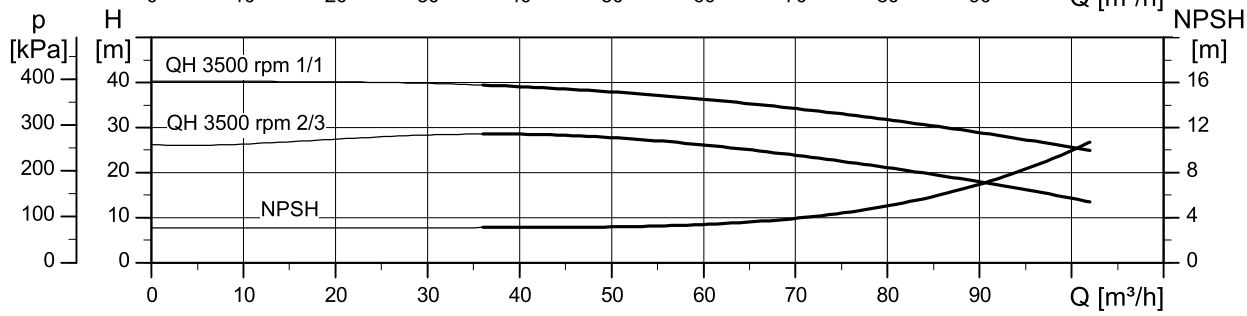
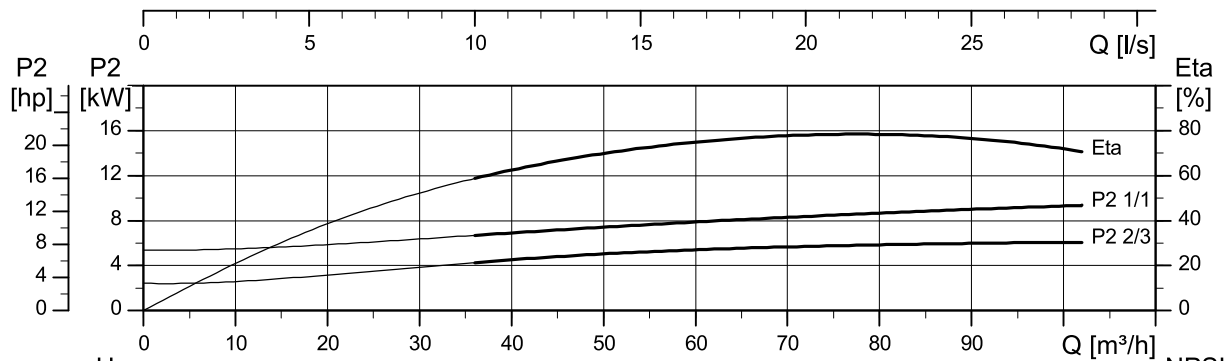
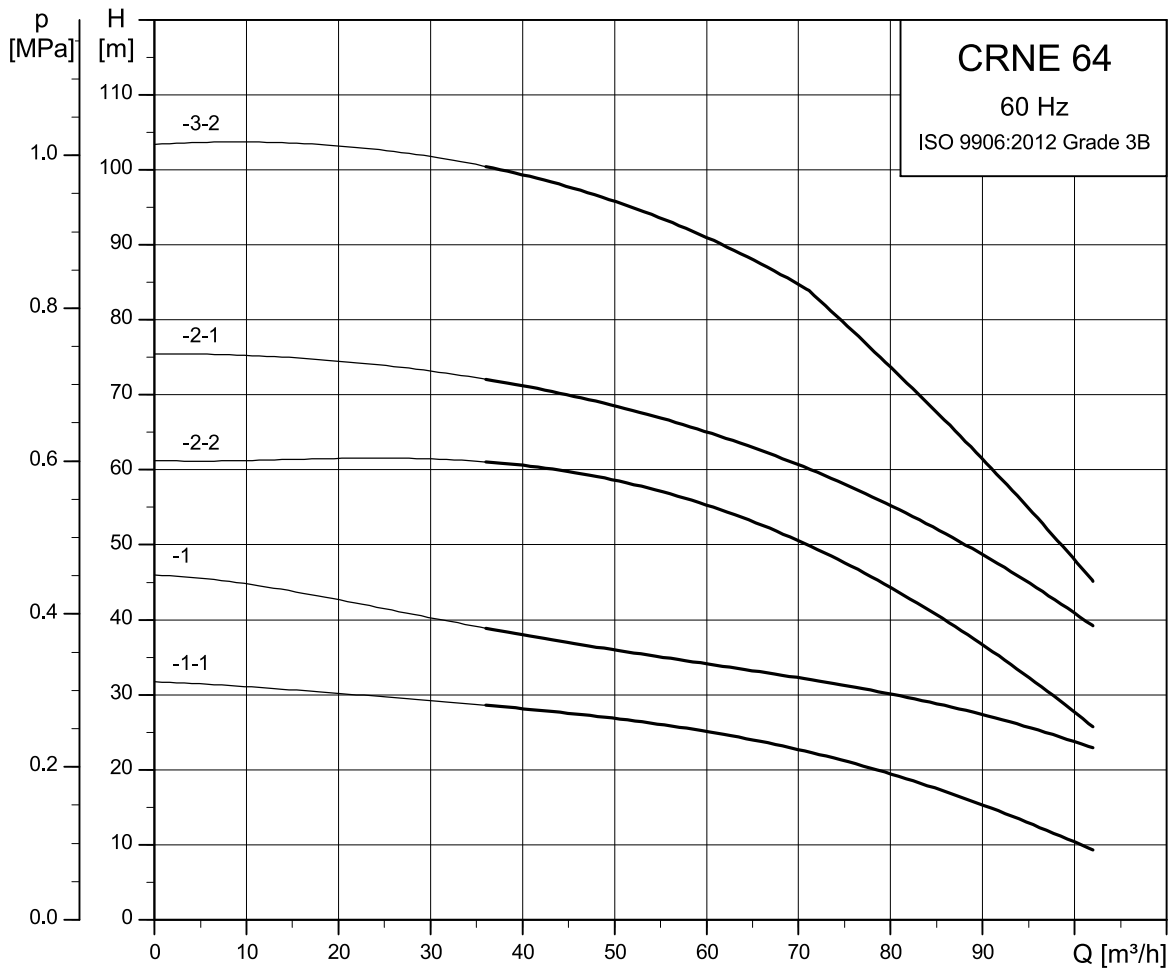

TM056850

Dimensional sketches

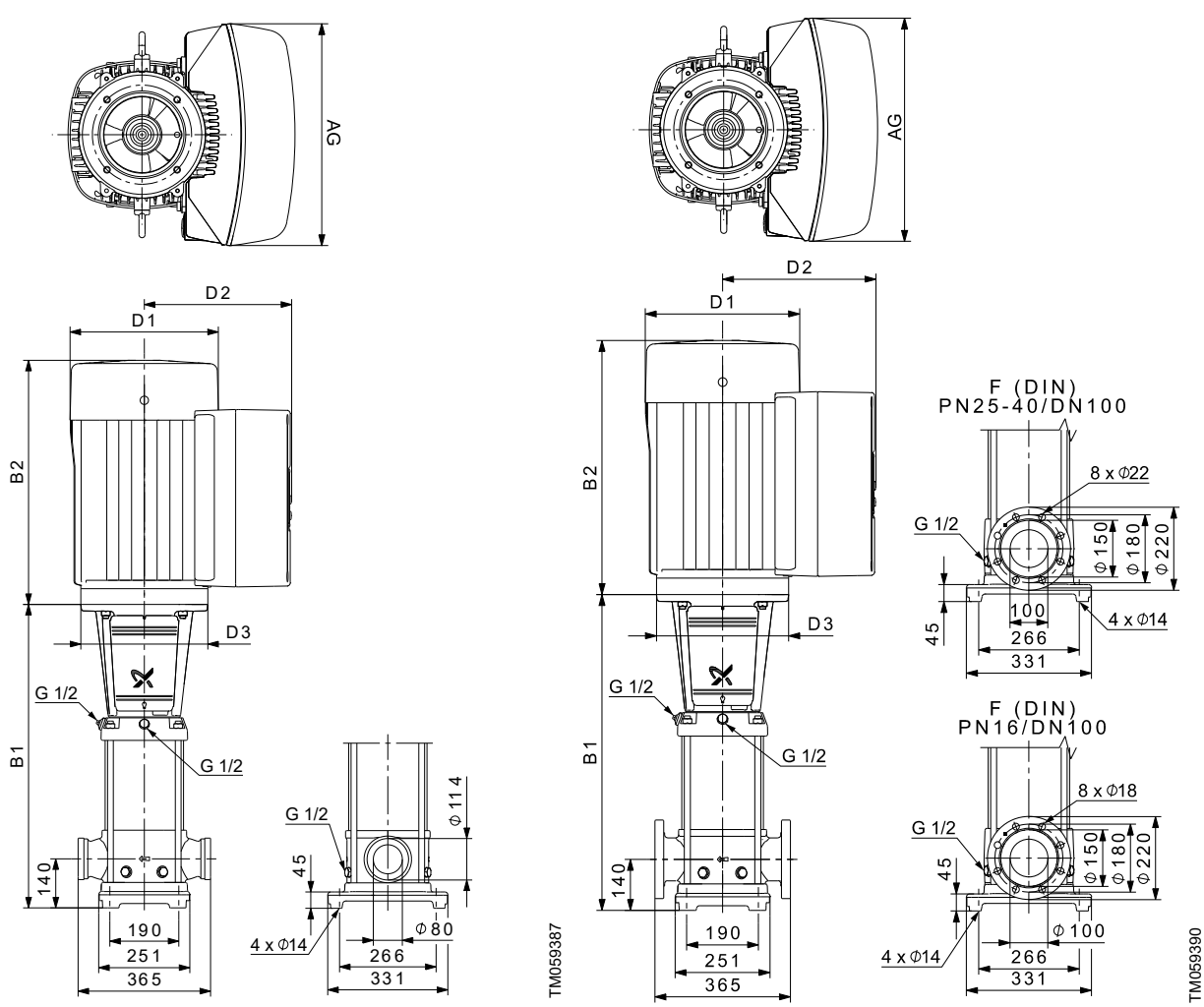

Dimensions and weights

Pump type	P ₂ [kW]	CRNE								Net weight [kg]	
		Dimension [mm]									
		PJE		DIN flange		D1	D2	D3	AG	PJE/CA	DIN flange
B1	B1+B2	B1	B1+B2								
CRNE 64-1-1	7.5	561	950	561	950	255	237	300	346	106	106
CRNE 64-1	11	671	1077	671	1077	255	237	350	346	132	132
CRNE 64-2-2	15	754	1236	754	1236	318	303	350	420	157	157
CRNE 64-2-1	18.5	754	1236	754	1236	318	303	350	420	161	161
CRNE 64-3-2	22	836	1344	836	1344	318	303	350	420	236	179

CRE 95

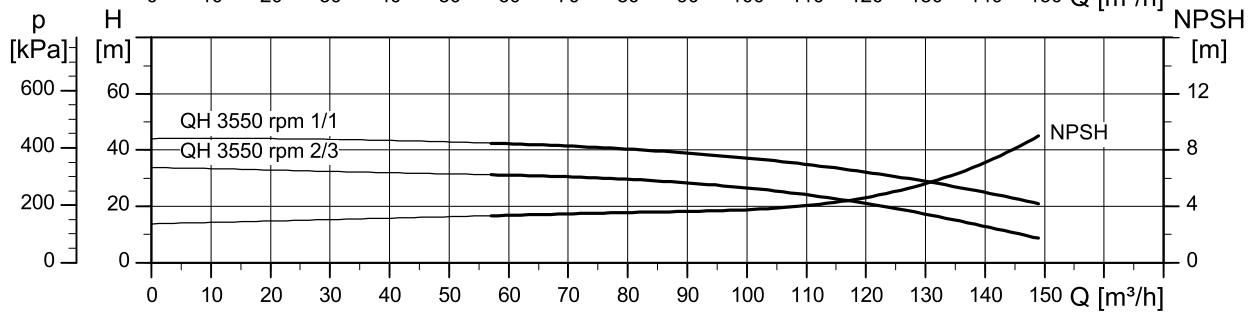
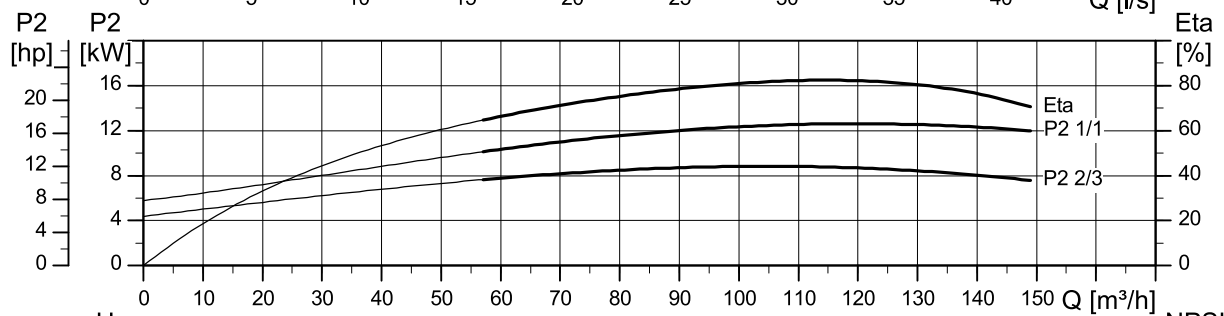
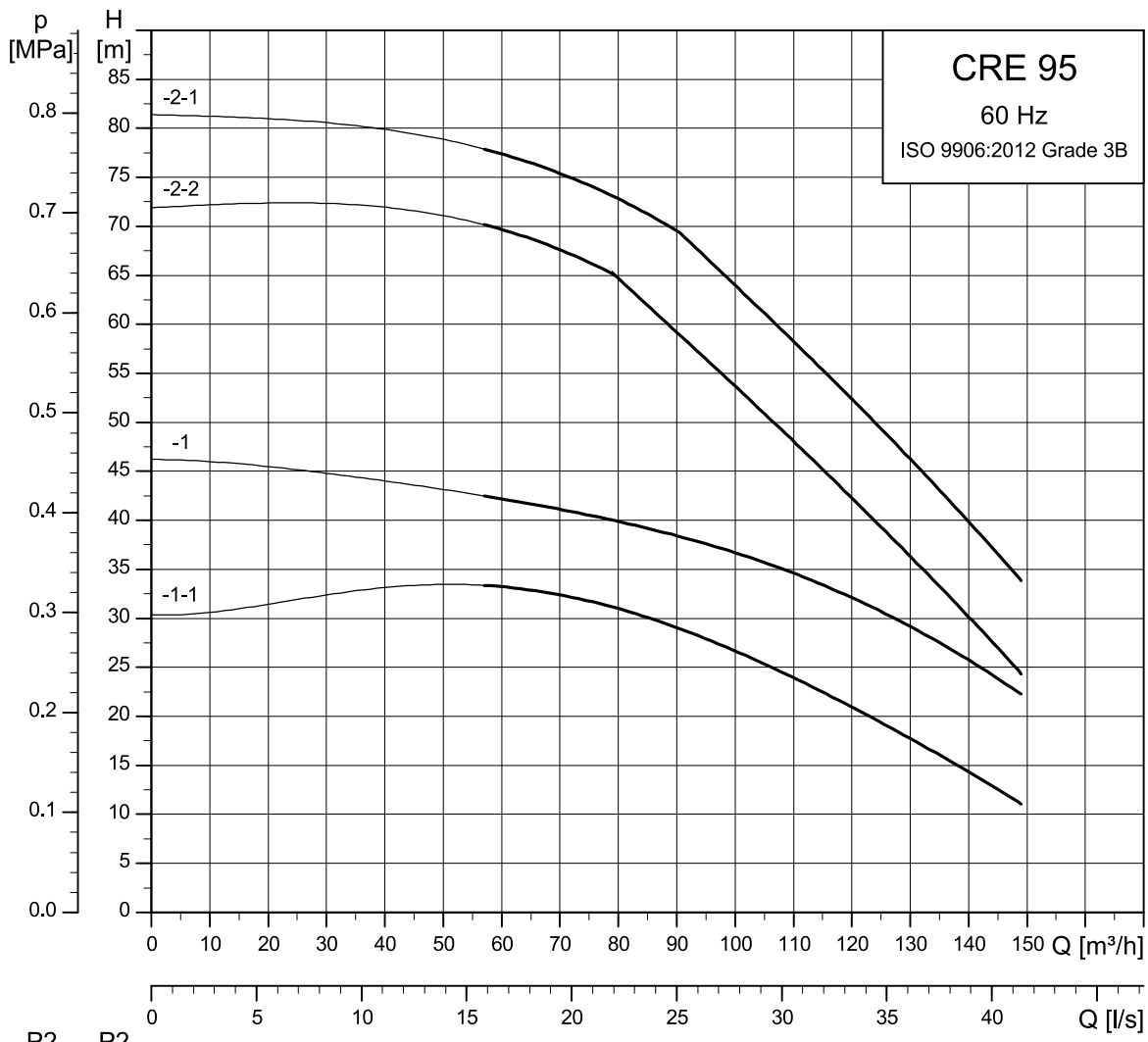

TM074489

Dimensional sketches

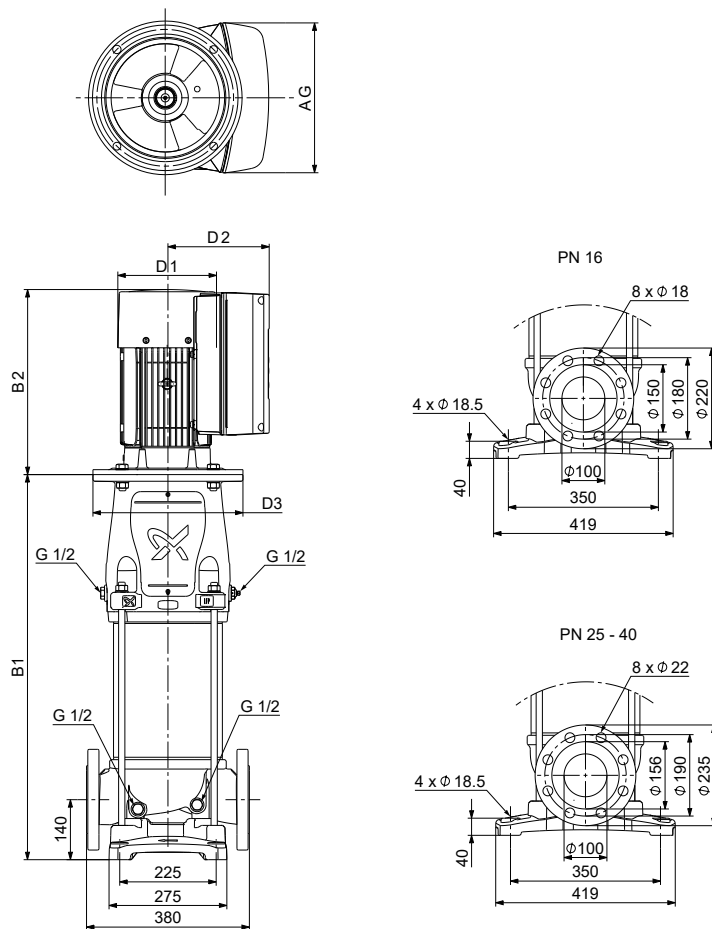

TM074392

Dimensions and weights

Pump type	P ₂ [kW]	CRE						Net weight [kg]
		Dimension [mm]						
		B1	B1+B2	D1	D2	D3	AG	
CRE 95-1-1	11	691	1097	255	237	350	346	165
CRE 95-1	15	691	1173	318	303	350	420	183
CRE 95-2-2	18.5	795	1277	318	303	350	420	193
CRE 95-2-1	22	795	1303	318	303	350	420	207

CRNE 95

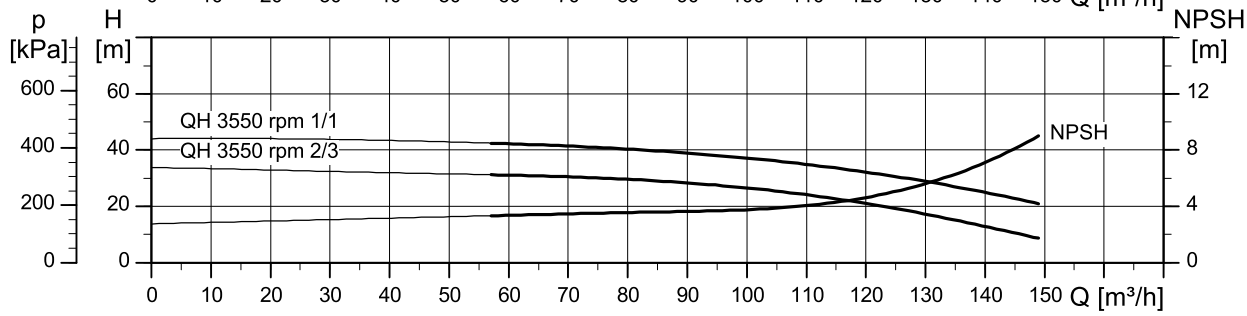
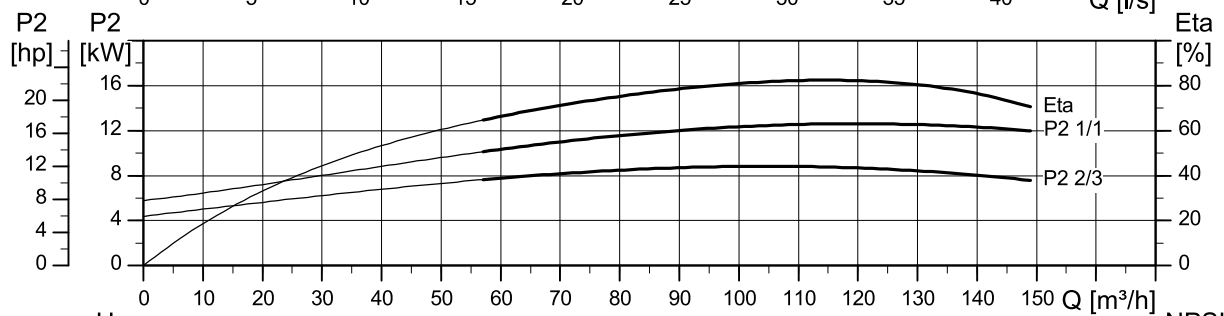
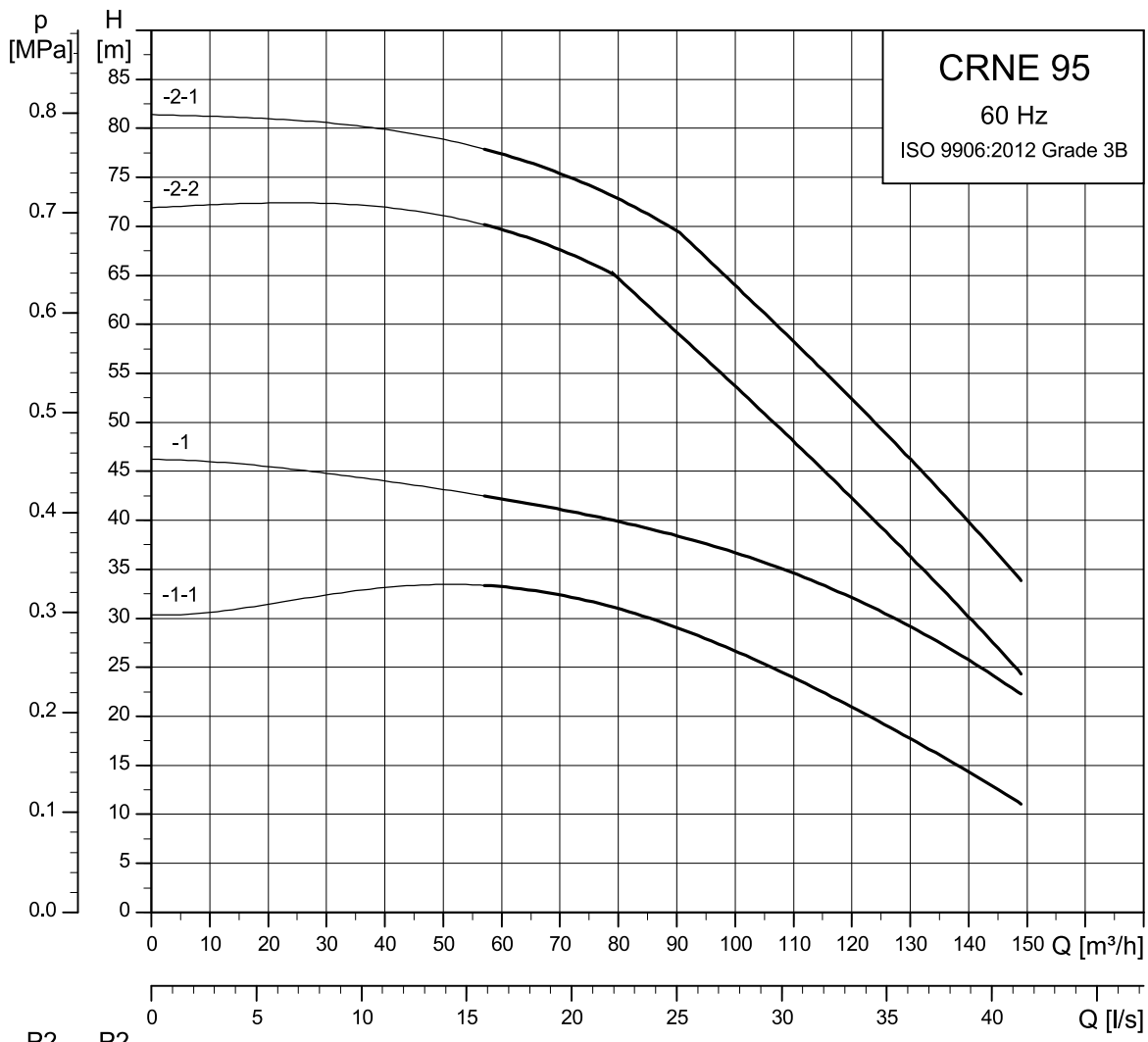

TM074490

CRE 125

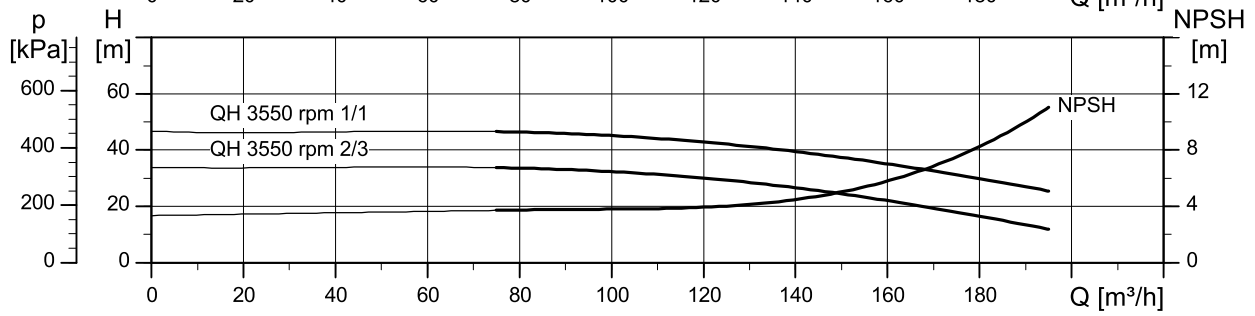
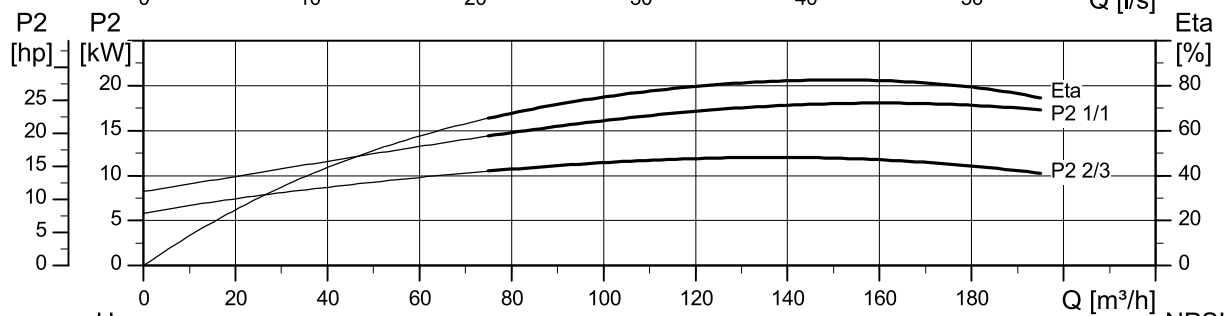
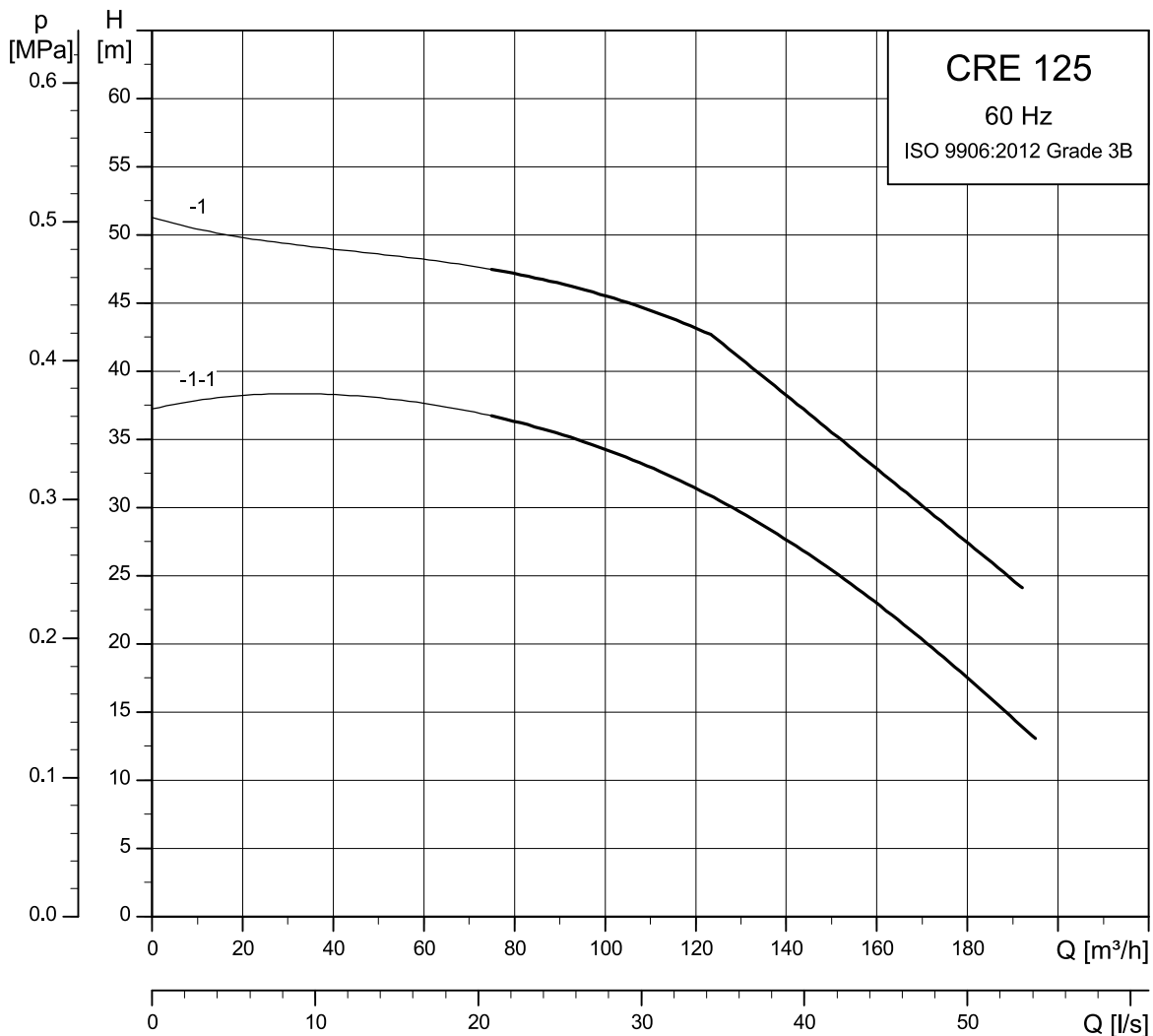

TM074491

Dimensional sketches

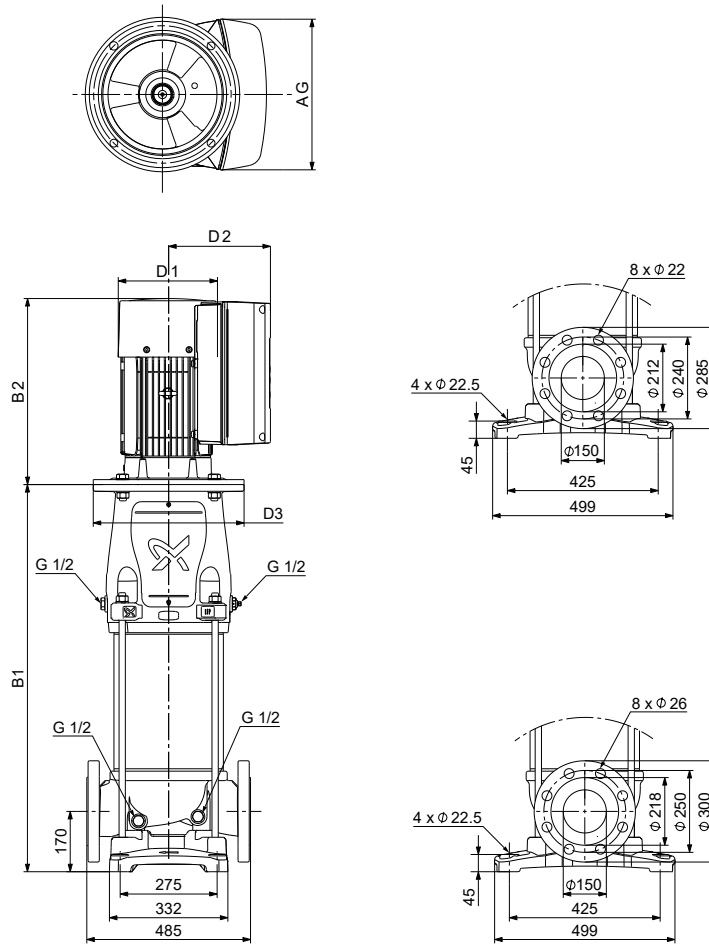

TM074393

Dimensions and weights

Pump type	P ₂ [kW]	CRE						Net weight [kg]
		Dimension [mm]						
		B1	B1+B2	D1	D2	D3	AG	
CRE 125-1-1	15	783	1265	318	303	350	420	228
CRE 125-1	22	783	1291	318	303	350	420	246

CRNE 125

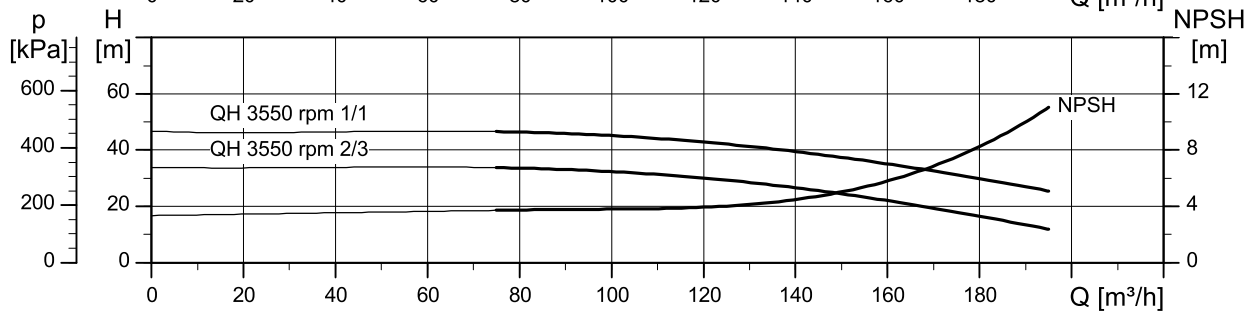
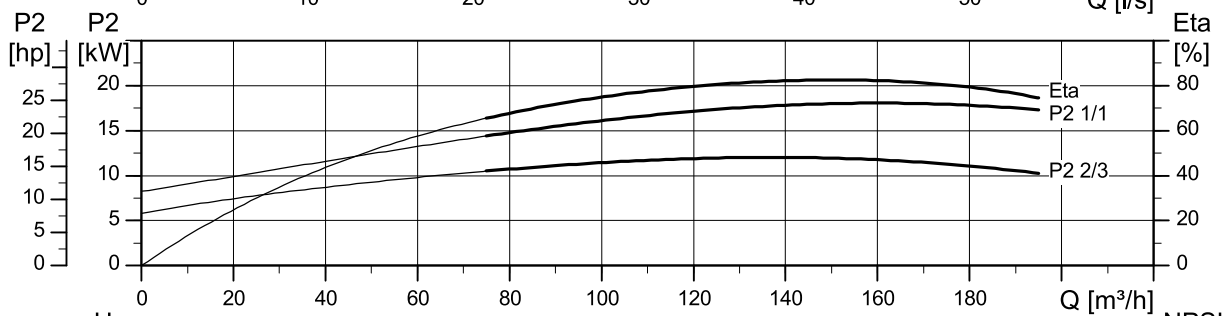
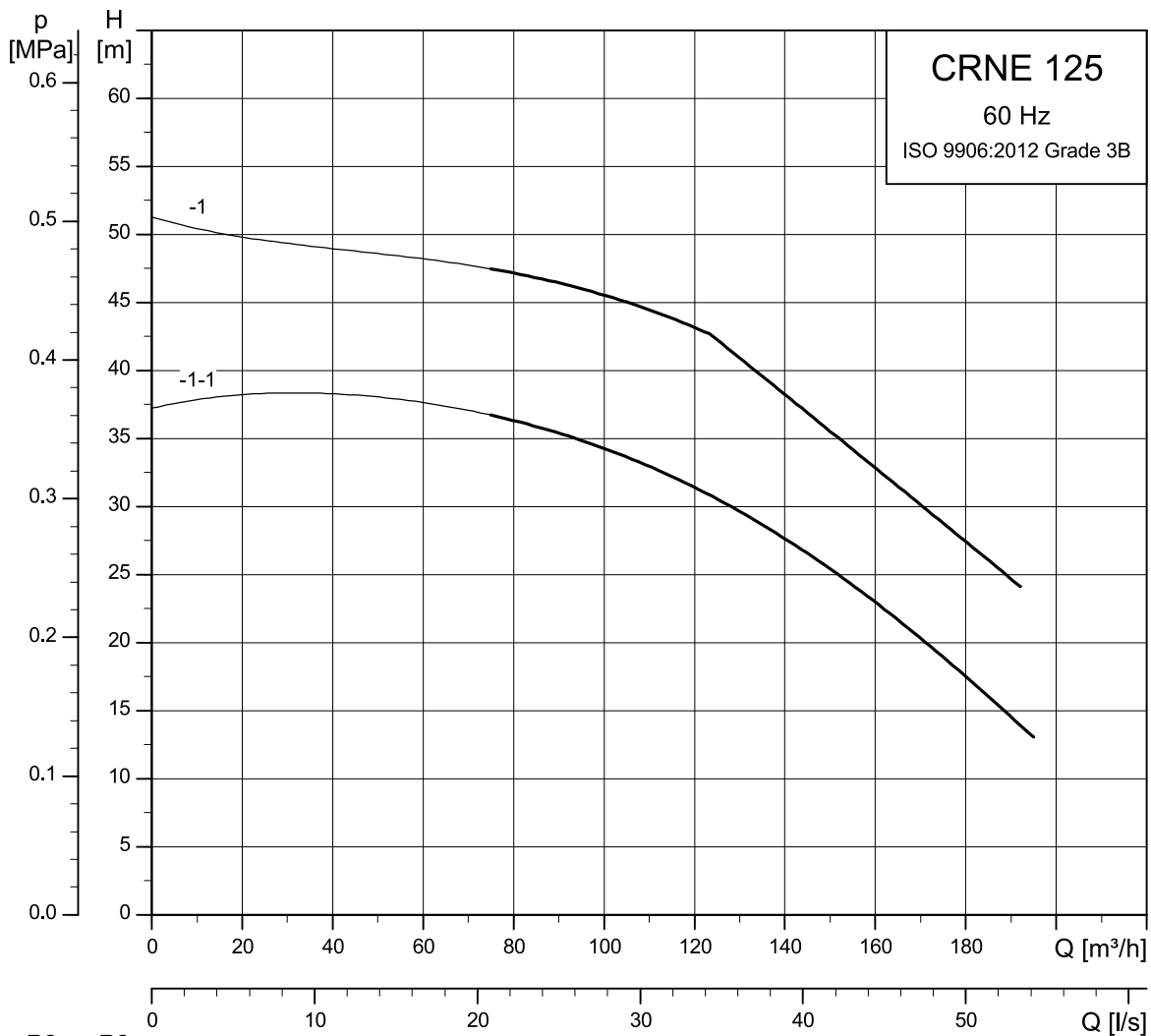

TM074492

Dimensional sketches

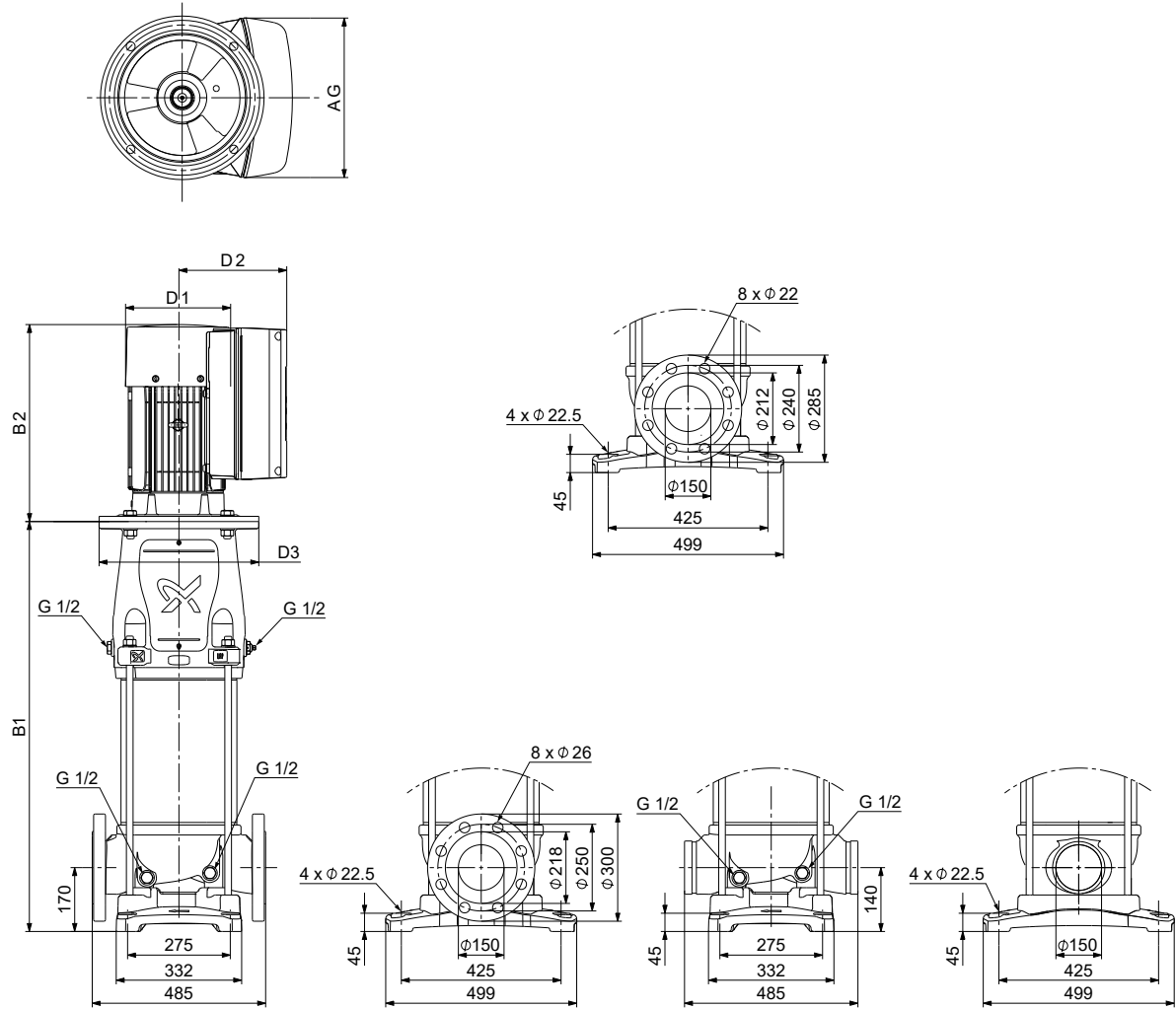

TM074391

Dimensions and weights

Pump type	P ₂ [kW]	CRNE						Net weight [kg]
		Dimension [mm]						
		B1	B1+B2	D1	D2	D3	AG	
CRNE 125-1-1	15	783	1265	318	303	350	420	228
CRNE 125-1	22	783	1291	318	303	350	420	246

CRE 155

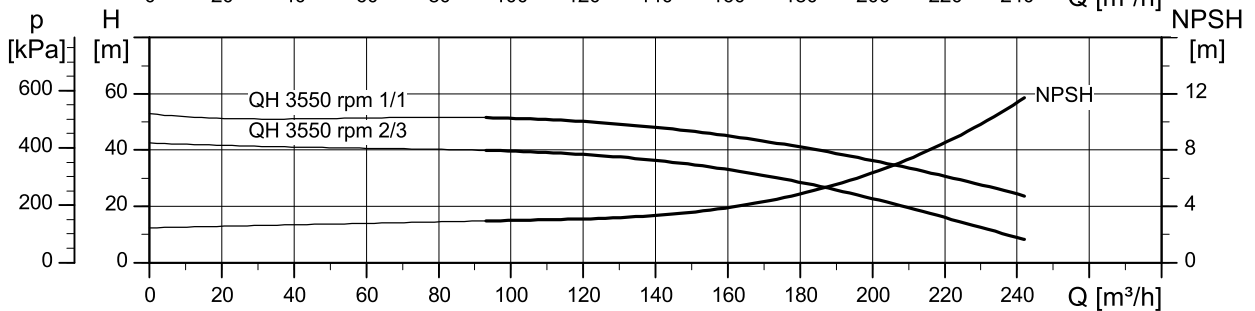
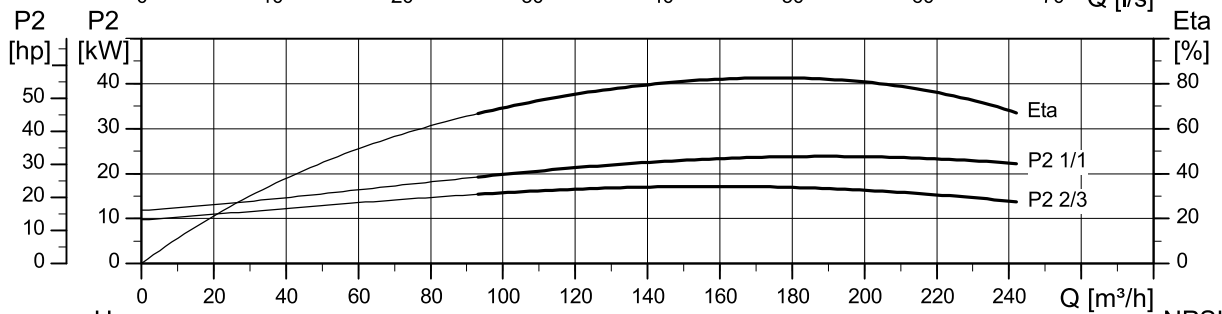
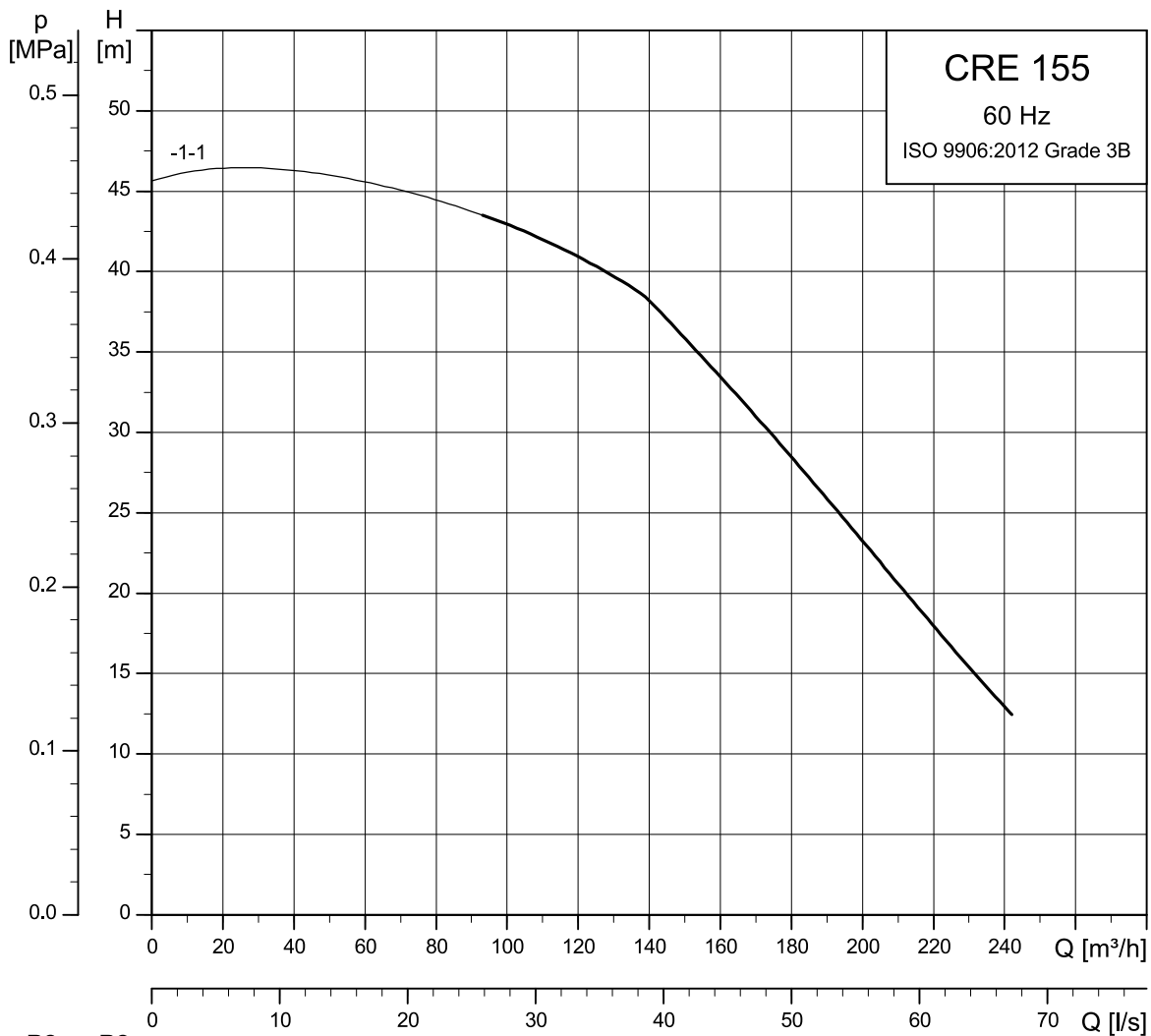

TM074493

Dimensional sketches

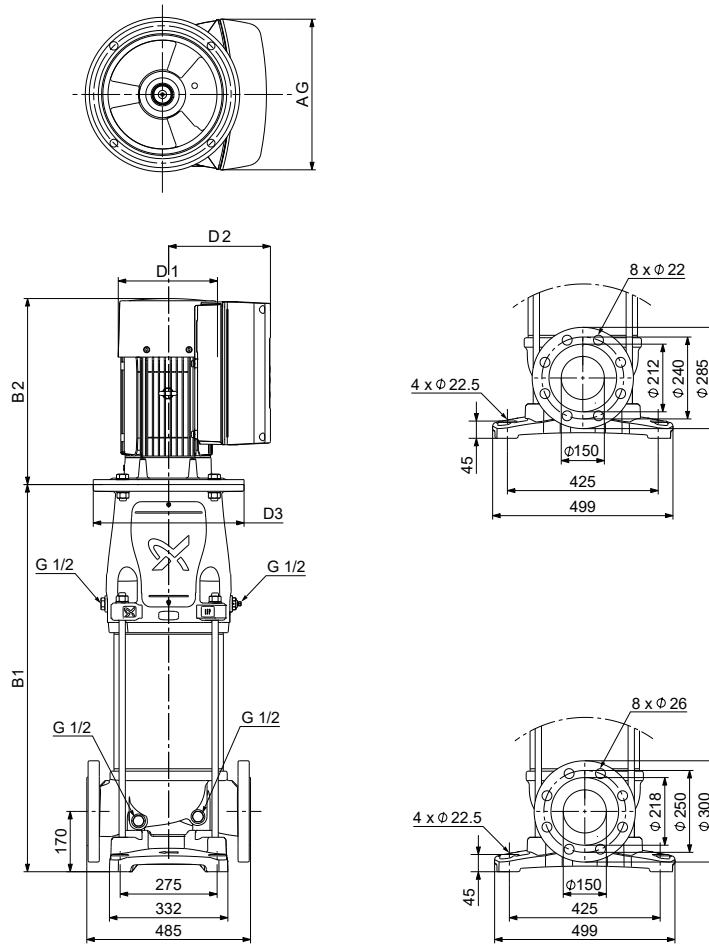

TM074393

Dimensions and weights

Pump type	P ₂ [kW]	CRE						Net weight [kg]
		Dimension [mm]						
		B1	B1+B2	D1	D2	D3	AG	
CRE 155-1-1	18.5	783	1265	318	303	350	420	233

CRNE 155

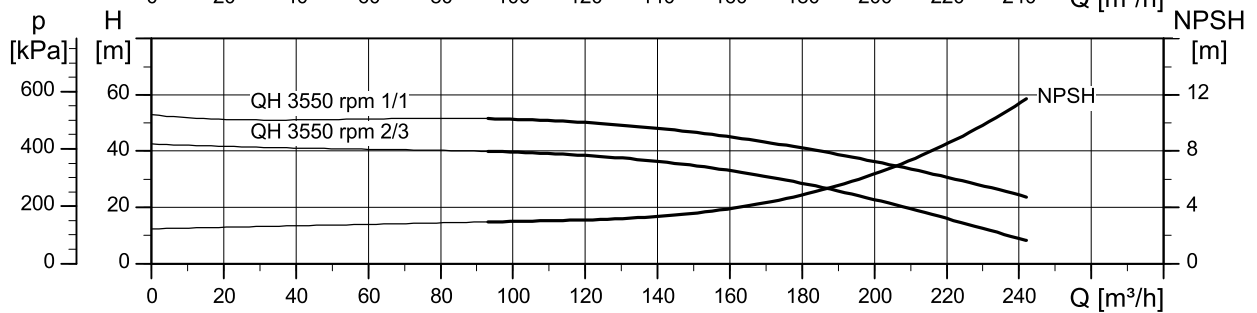
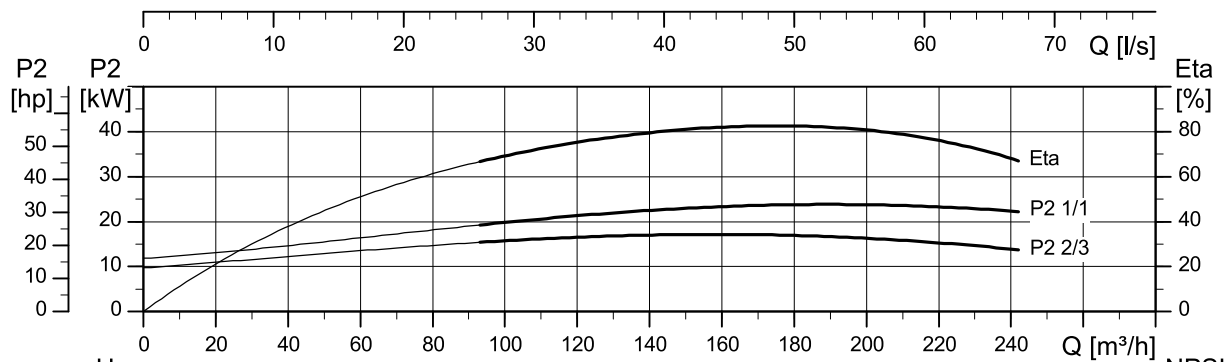
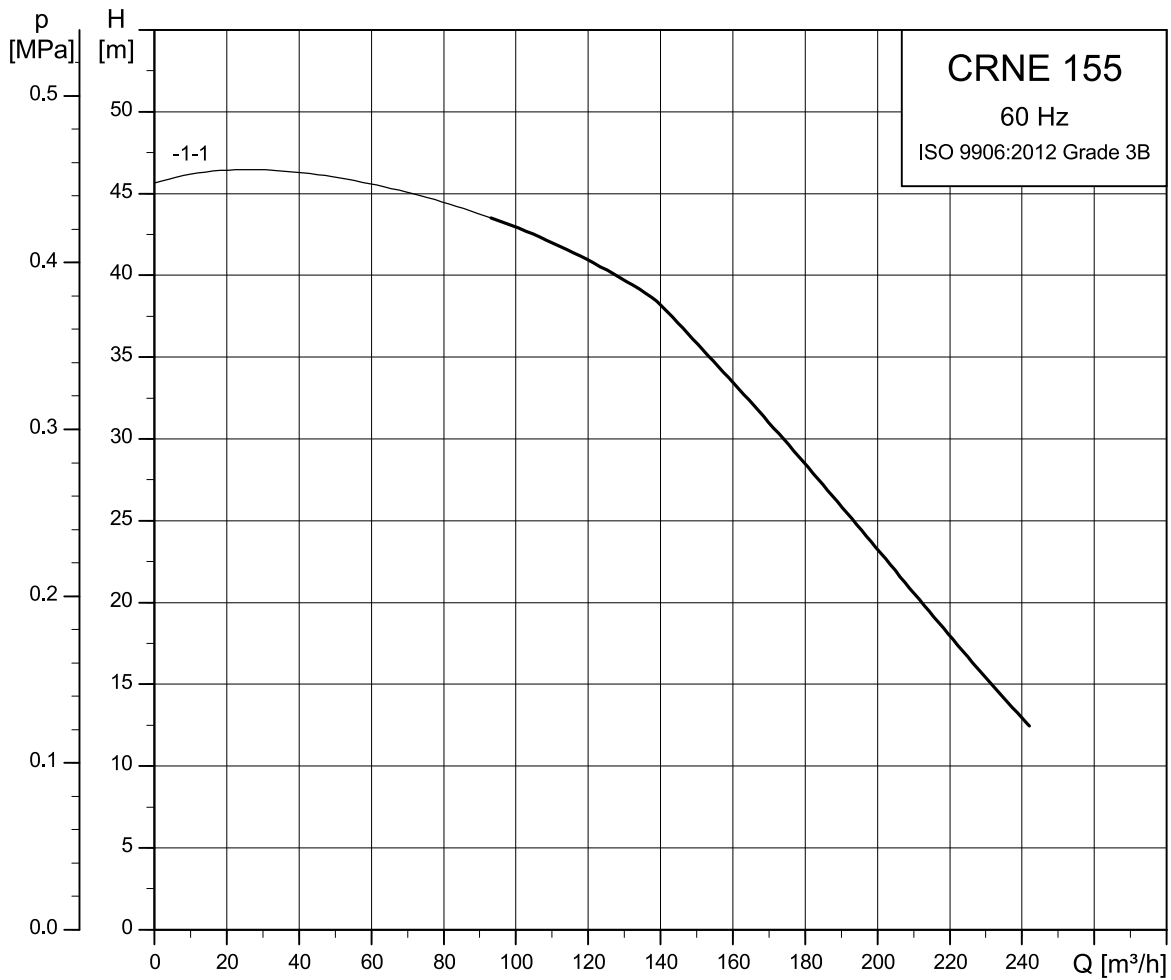

TM074494

Dimensional sketches

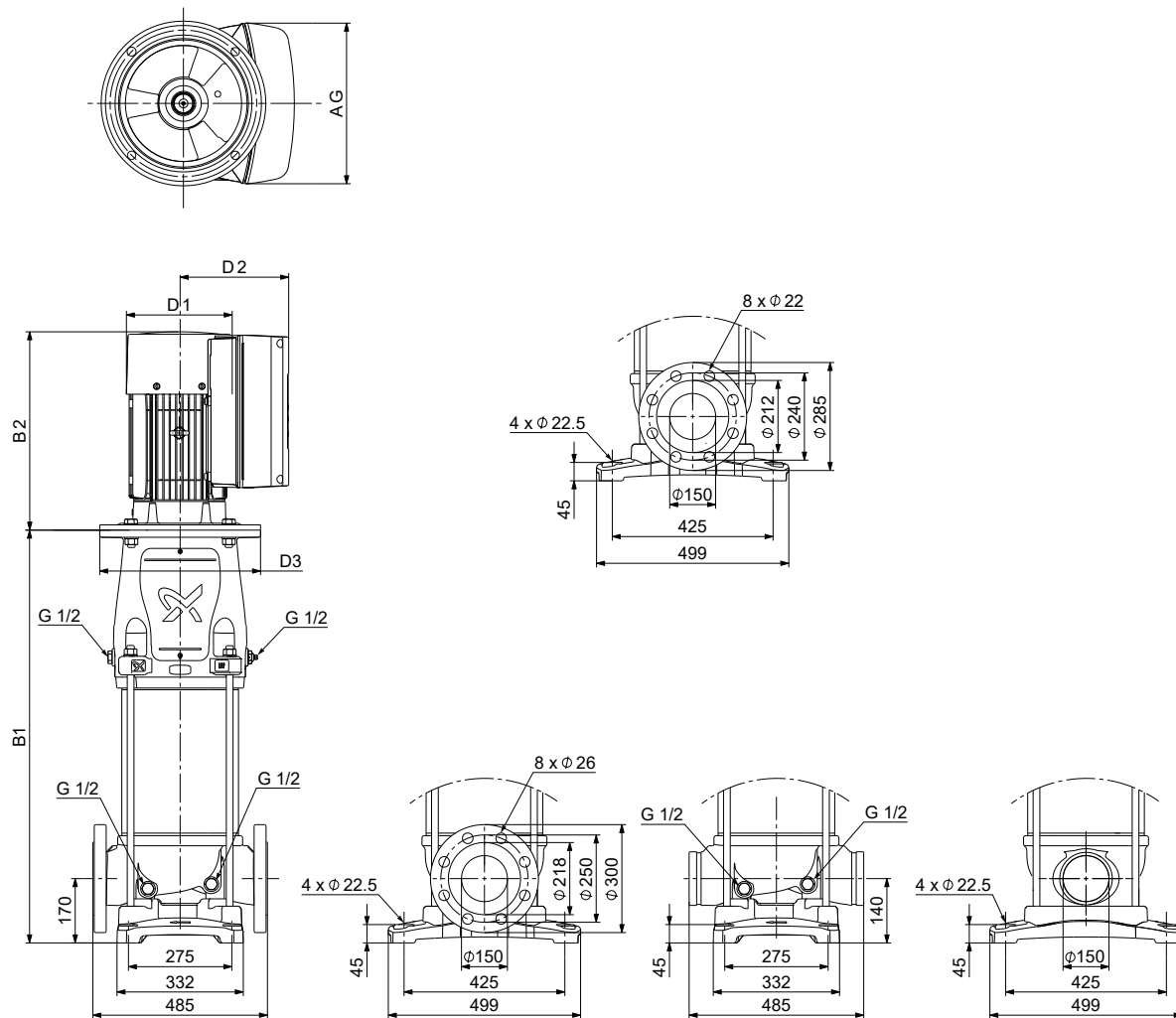

TM074391

Dimensions and weights

Pump type	P ₂ [kW]	CRNE						Net weight [kg]
		Dimension [mm]						
		B1	B1+B2	D1	D2	D3	AG	
CRNE 155-1-1	18.5	783	1265	318	303	350	420	233

11. Motor data

E-motors, 50/60 Hz

Motor make	P2 [kW]	Frame size	Phase	Standard voltage [V]	I _{1/1} [A]	Cos φ _{1/1}	η [%]	Motor efficiency class
Grundfos MGE	0.37 ²⁸⁾	71	1	200-240	2.4 - 2.1	0.96	84	IE5
	0.55 ²⁸⁾	71	1	200-240	3.45 - 2.9	0.98	85.3	IE5
	0.75 ²⁸⁾	80	1	200-240	4.7 - 3.9	0.99	85.2	IE5
	1.1 ²⁸⁾	80	1	200-240	6.7 - 5.6	0.99	86.9	IE5
	1.5 ²⁸⁾	90	1	200-240	9.1 - 7.6	0.99	87.4	IE5
	0.37	71	3	380-500	1.05 - 1.0	0.68 - 0.54	84.5	IE5
	0.55	71	3	380-500	1.35 - 1.3	0.77 - 0.61	85.9	IE5
	0.75	80	3	380-500	1.7 - 1.6	0.83 - 0.67	85.9	IE5
	1.1	80	3	380-500	2.2 - 1.9	0.89 - 0.79	89.1	IE5
	1.5	90	3	380-500	2.9 - 2.4	0.92 - 0.85	88.9	IE5
	2.2	90	3	380-500	4.15 - 3.4	0.93 - 0.87	90.1	IE5
	3	100	3	380-500	5.8 - 4.8	0.91 - 0.86	90.7	IE5
	4	112	3	380-500	7.6 - 6.2	0.92 - 0.87	92.2	IE5
	5.5	132	3	380-500	10.3 - 8.2	0.92 - 0.88	92.7	IE5
	7.5	132	3	380-500	14.1 - 11.2	0.93 - 0.89	92.5	IE5
	11	160	3	380-500	20.3 - 16.0	0.93 - 0.90	93.1	IE5
	15	160	3	380-500	26.7-22.0	0.94 - 0.92	92.8	IE5
	18.5	160	3	380-500	33.0-27.8	0.94 - 0.92	92.8	IE5
	22	180	3	380-500	39.2-31.5	0.94 - 0.93	92.9	IE5

²⁸⁾ Pumps are normally fitted with three-phase MGE motors. Dimension tables in the section on performance curves and technical data show pumps with three-phase MGE motors.

12. Accessories

Pipe connection

Various sets of counterflanges and couplings are available for pipe connection.

Adapter kit

DN 150 flanges are available for CRE, CRNE 125 and 155 pumps. To use DN 150 flanges, you must order two adapter kits per pump.

Pump type	Pipe connection	Adapter kits required	Product number	Adapter kit
CRE 125	150 mm, nominal	2	96638169	
CRE 155	150 mm, nominal	2	96638180	
CRNE 125				
CRNE 155				

We offer an optional 6-inch pump base for the CRN 95, 125 and 155 pump ranges with DN 150 connections according to DIN, ANSI and JIS standards. This base eliminates the need for an adapter kit.

For more information, see the data booklet for CR Custom-built pumps in Grundfos Product Center at www.grundfos.com.

Counterflanges for CRE

A set consists of one counterflange, one gasket, bolts and nuts.

Pump type	Description	Rated pressure	Pipe connection	Product number	Counterflange	
CRE 1s CRE 1 CRE 3 CRE 5	Threaded	16 bar EN 1092-2	Rp 1	409901		
	For welding	25 bar EN 1092-2	25 mm, nominal	409902		
	CRE 1s CRE 1 CRE 3 CRE 5	Threaded	16 bar EN 1092-2	Rp 1 1/4	419901	
		For welding	25 bar EN 1092-2	32 mm, nominal	419902	
CRE 10		Threaded	16 bar EN 1092-2	Rp 1 1/2	429902	
		Threaded	16 bar EN 1092-2	Rp 2	429904	
	For welding	25 bar EN 1092-2	40 mm, nominal	429901		
	For welding	40 bar special flange	50 mm, nominal	429903		

Pump type	Description	Rated pressure	Pipe connection	Product number	Counterflange
CRE 15 CRE 20	Threaded	16 bar EN 1092-2	Rp 2	339903	
	Threaded	16 bar special flange	Rp 2 1/2	339904	
	For welding	25 bar EN 1092-2	50 mm, nominal	339901	
	For welding	40 bar special flange	65 mm, nominal	339902	
CRE 15 CRE 20	Threaded	16 bar special flange	Rp 2 1/2 ²⁹⁾	96509578	
CRE 32	Threaded	16 bar EN 1092-2	Rp 2 1/2	349902	
	Threaded	16 bar special flange	Rp 3	349901	
	For welding	16 bar EN 1092-2	65 mm, nominal	349904	
	For welding	40 bar DIN 2635	65 mm, nominal	349905	
	For welding	16 bar special flange	80 mm, nominal	349903	
CRE 45	Threaded	16 bar	Rp 3	350540	
	For welding	16 bar	80 mm, nominal	350541	
	For welding	40 bar	80 mm, nominal	350542	
CRE 64	Threaded	16 bar EN 1092-2	Rp 4	369901	
	For welding	16 bar EN 1092-2	100 mm, nominal	369902	
	For welding	25 bar EN 1092-2	100 mm, nominal	369905	

Pump type	Description	Rated pressure	Pipe connection	Product number	Counterflange	
CRE 95	For welding	16 bar EN 1092-2	100 mm, nominal	99432754		
	For welding	25/40 bar EN 1092-2	100 mm, nominal	99432755		
CRE 125 CRE 155	For welding	16 bar EN 1563	150 mm, nominal	99432761		
	For welding	25/40 bar EN 1563	150 mm, nominal	99432760		

TM065157

TM038891

TM065171

²⁹⁾ Flange with 20 mm higher collar. With this collar, the installation dimensions of a CR 20 will be identical to those of a CR 32. If a CR 32 is replaced by a CR 20, the base must be raised by 15 mm.

Counterflanges for CRNE

Counterflanges for CRN pumps are made of stainless steel EN 1.4401 (≈AISI 316).
A set consists of one counterflange, one gasket, bolts and nuts.

Pump type	Description	Rated pressure	Pipe connection	Product number	Counterflange
CRNE 1s CRNE 1 CRNE 3 CRNE 5	Threaded	16 bar EN 1092-1	Rp 1	405284	
	For welding	25 bar EN 1092-1	25 mm, nominal	405285	
CRNE 1s CRNE 1 CRNE 3 CRNE 5	Threaded	16 bar EN 1092-1	Rp 1 1/4	415304	
	For welding	25 bar EN 1092-1	32 mm, nominal	415305	
CRNE 10	Threaded	16 bar EN 1092-1	Rp 1 1/2	425245	
CRNE 10	Threaded	16 bar EN 1092-1	Rp 2	96509570	
CRNE 10	For welding	25 bar EN 1092-1	40 mm, nominal	425246	
CRNE 10	For welding	25 bar special flange	50 mm, nominal	96509571	
CRNE 15 CRNE 20	Threaded	16 bar EN 1092-1	Rp 2	335254	

Pump type	Description	Rated pressure	Pipe connection	Product number	Counterflange	
CRNE 15 CRNE 20	Threaded	16 bar special flange	Rp 2 1/2	96509575		TM051005
CRNE 15 CRNE 20	For welding	25 bar EN 1092-1	50 mm, nominal	335255		TM030402
CRNE 15 CRNE 20	For welding	25 bar special flange	65 mm, nominal	96509573		TM027203
CRNE 32	Threaded	16 bar	Rp 2 1/2	349910		TM050994
	Threaded	16 bar special flange	Rp 3	349911		
	For welding	16 bar	65 mm, nominal	349906		
	For welding	40 bar	65 mm, nominal	349908		
					16 bar 16/40 bar 16/25 bar	
CRNE 45	Threaded	16 bar	Rp 3	350543		TM050996
	For welding	16 bar	80 mm, nominal	350544		
	For welding	40 bar	80 mm, nominal	350545		
					16 bar 16/40 bar	
CRNE 64	Threaded	16 bar	Rp 4	369904		TM050995
	For welding	16 bar	100 mm, nominal	369903		
	For welding	40 bar	100 mm, nominal	369906		
					16 bar 16 bar 40 bar	

Pump type	Description	Rated pressure	Pipe connection	Product number	Counterflange	
CRNE 95	For welding	16 bar EN 1.4408	100 mm, nominal	99432731		TM065157
	For welding	25/40 bar EN 1.4408	100 mm, nominal	99432732		
CRNE 125 CRNE 155	For welding	16 bar EN 1.4408	150 mm, nominal	99432733		TM038891
	For welding	25/40 bar EN 1.4408	150 mm, nominal	99432734		

PJE couplings for CRNE

Materials in contact with the pumped liquid are made of stainless steel EN 1.4401 (≈AISI 316) and rubber.

A set consists of two coupling halves (Victaulic type 77), one gasket, one pipe stub (for welding or threaded), bolts and nuts.

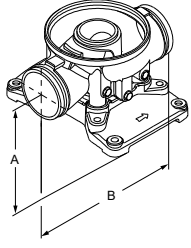
Pump type	Pipe stub	Maximum pressure [bar]	A [mm]	B [mm]	Pipe connection	Rubber parts	Number of coupling sets required	Product number	Coupling
CRNE 1s	Threaded	69	50	320	R 1 1/4	EPDM	2	419911	
CRNE 1						FKM	2	419905	
CRNE 3	For welding	69	50	280	DN 32	EPDM	2	419912	
CRNE 5						FKM	2	419904	
CRNE 10	Threaded	69	80	377	R 2	EPDM	2	339911	
CRNE 15						FKM	2	339918	
CRNE 20	For welding	69	80	371	DN 50	EPDM	2	339910	
						FKM	2	339917	
CRNE 32	For welding	69	105	420	DN 80	EPDM	2	98144746	
						FKM	2	98144749	
CRNE 45	For welding	69	140	465	DN 100	EPDM	2	98144752	
CRNE 64						FKM	2	98144755	
CRNE 95	For welding	69	140	465	DN 100	EPDM	2	98144752	
						FKM	2	98144755	
CRNE 125	For welding	69	-	-	DN 150	EPDM	2	-	
CRNE 155			FKM	-		-	FKM	2	-

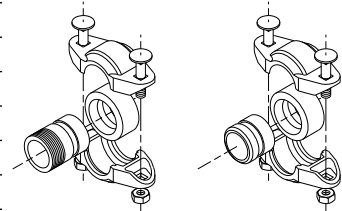

TM069172

TM003808

FlexiClamp base connections

All sets comprise the necessary number of bolts and nuts as well as a gasket or O-ring.

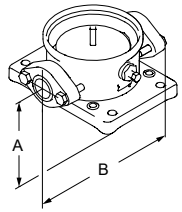
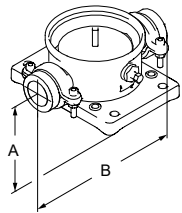
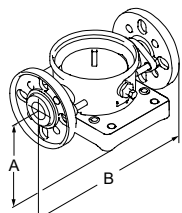
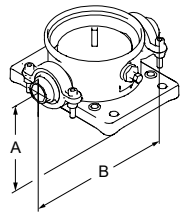
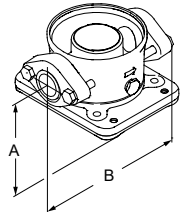
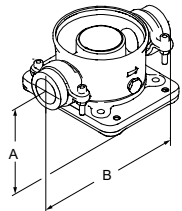
Pump type	Connection	Pipe connection	PN	A [mm]	B [mm]	Rubber parts	Number of coupling sets required	Product number	Base connection	
CRIE, CRNE 1s CRIE, CRNE 1 CRIE, CRNE 3 CRIE, CRNE 5	Oval (cast iron)	Rp 1	16	50	210	Klingsil	1	96449748	 TM027368	
		Rp 1 1/4	16	50	210	Klingsil	1	96449749		
	Oval (stainless steel)	Rp 1	16	50	210	Klingsil	2	96449746		
		Rp 1 1/4	16	50	210	Klingsil	2	96449747		
		Union	G 2	25	50	228	EPDM	2		96449743
CRIE, CRNE 1s CRIE, CRNE 1 CRIE, CRNE 3 CRIE, CRNE 5	Union	G 2	25	50	228	FKM	2	96449744	 TM027369	
CRIE, CRNE 1s CRIE, CRNE 1 CRIE, CRNE 3 CRIE, CRNE 5	DIN (stainless steel)	DN 25	16	75	250	EPDM	2	96449745	 TM027370	
		DN 32				FKM				
		DN 25	16	75	250	EPDM	2	96449900		
		DN 32				FKM				
CRIE, CRNE 1s CRIE, CRNE 1 CRIE, CRNE 3 CRIE, CRNE 5	Clamp, threaded pipe stub	Rp 1	25	50	208	EPDM	2	405280	 TM027371	
		Rp 1	25	50	208	FKM	2	405281		
		Rp 1 1/4	25	50	208	EPDM	2	415296		
		Rp 1 1/4	25	50	208	FKM	2	415297		
		1" NPT	25	50	208	EPDM	2	405291		
		1" NPT	25	50	208	FKM	2	405292		
		1 1/4" NPT	25	50	208	EPDM	2	415311		
		1 1/4" NPT	25	50	208	FKM	2	415312		
		Clamp, pipe stub for welding	28.5	25	50	-	EPDM	2		405282
			28.5	25	50	-	FKM	2		405283
			37.2	25	50	-	EPDM	2		415300
			37.2	25	50	-	FKM	2		415301
CRIE, CRNE 10	Oval (cast iron)	Rp 1 1/4	16	80	260	Klingsil	2	96498775	 TM027372	
		Rp 1 1/2	16	80	260	Klingsil	2	96498727		
		Rp 2	16	80	260	Klingsil	2	96498836		
	Oval (stainless steel)	Rp 1 1/4	16	80	260	Klingsil	2	96498776		
		Rp 1 1/2	16	80	260	Klingsil	2	96498728		
		Rp 2	16	80	260	Klingsil	2	96498835		
CRIE, CRNE 10	Union	G 2 3/4	25	80	288	EPDM	2	96500275	 TM027374	
		G 2 3/4	25	80	288	FKM	2	96500276		

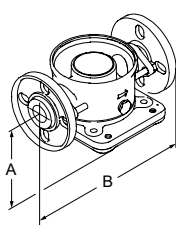
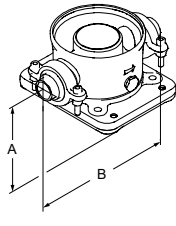
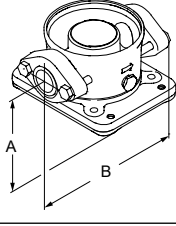
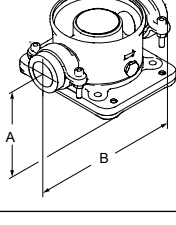
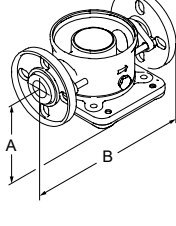
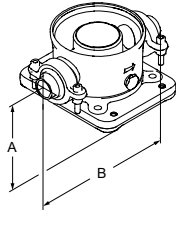
Pump type	Connection	Pipe connection	PN	A [mm]	B [mm]	Rubber parts	Number of coupling sets required	Product number	Base connection
CRIE, CRNE 10	FGJ (cast iron)	DN 40	16	80	316	EPDM	2	96498840	 TM027373
		DN 40	16	80	316	FKM	2	96500119	
	FGJ (stainless steel)	DN 40	16	80	316	EPDM	2	96500263	
		DN 40	16	80	316	FKM	2	96500264	
	FGJ (cast iron)	DN 50	16	80	316	EPDM	2	96500265	
		DN 50	16	80	316	FKM	2	96500266	
FGJ (stainless steel)	DN 50	16	80	316	EPDM	2	96500267		
CRIE, CRNE 10	Clamp, threaded pipe stub	Rp 1 1/2	25	80	259	EPDM	2	425238	 TM027375
		Rp 1 1/2	25	80	259	FKM	2	425239	
		Rp 2	25	80	259	EPDM	2	335241	
		Rp 2	25	80	259	FKM	2	335242	
		Rp 2 1/2	25	80	346	EPDM	2	96508600	
	Clamp, pipe stub for welding	Rp 2 1/2	25	80	346	FKM	2	96508601	
		48.3 (DN 40)	25	80	-	EPDM	2	425242	
		48.3 (DN 40)	25	80	-	FKM	2	425243	
		60.3 (DN 50)	25	80	-	EPDM	2	335251	
		60.3 (DN 50)	25	80	-	FKM	2	335252	
CRIE, CRNE 15 CRIE, CRNE 20	Oval (cast iron)	Rp 1 1/4	10	90	260	Klingersil	2	96498775	 TM027372
		Rp 1 1/2	10	90	260	Klingersil	2	96498727	
		Rp 2	10	90	260	Klingersil	2	96498836	
	Oval (stainless steel)	Rp 1 1/4	10	90	260	Klingersil	2	96498776	
		Rp 1 1/2	10	90	260	Klingersil	2	96498728	
		Rp 2	10	90	260	Klingersil	2	96498835	
CRIE, CRNE 15 CRIE, CRNE 20	Union	G 2 3/4	25	90	288	EPDM	2	96500275	 TM027374
		G 2 3/4	25	90	288	FKM	2	96500276	
CRIE, CRNE 15 CRIE, CRNE 20	FGJ (cast iron)	DN 40	10	90	334	EPDM	2	96498840	 TM027373
		DN 40	10	90	334	FKM	2	96500119	
	FGJ (stainless steel)	DN 40	10	90	334	EPDM	2	96500263	
		DN 40	10	90	334	FKM	2	96500264	
	FGJ (cast iron)	DN 50	10	90	334	EPDM	2	96500265	
		DN 50	10	90	334	FKM	2	96500266	
FGJ (stainless steel)	DN 50	10	90	334	EPDM	2	96500267		
CRIE, CRNE 15 CRIE, CRNE 20	Clamp, threaded pipe stub	Rp 1 1/2	25	90	259	EPDM	2	425238	 TM027375
		Rp 1 1/2	25	90	259	FKM	2	425239	
		Rp 2	25	90	259	EPDM	2	335241	
		Rp 2	25	90	259	FKM	2	335242	
		Rp 2 1/2	25	90	346	EPDM	2	96508600	
	Clamp, pipe stub for welding	Rp 2 1/2	25	90	346	FKM	2	96508601	
		48.3 (DN 40)	25	90	-	EPDM	2	425242	
		48.3 (DN 40)	25	90	-	FKM	2	425243	
		60.3 (DN 50)	25	90	-	EPDM	2	335251	
		60.3 (DN 50)	25	90	-	FKM	2	335252	

Potentiometer

The potentiometer is suitable for setpoint setting and start and stop of the CRE, CRIE, CRNE pump.

Product	Product number
External potentiometer with cabinet for wall mounting	625468

EMC filter

The EMC filter is required when 11 to 22 kW E-pumps are installed in residential areas.

Product	Product number
EMC filter (11 kW)	96478309
EMC filter (15 kW)	
EMC filter (18.5 kW)	
EMC filter (22 kW)	

LiqTec

The LiqTec dry-running protection unit protects the pump and process against dry running and temperatures exceeding 130 ± 5 °C. Connected to the motor PTC sensor, LiqTec also monitors the motor temperature. LiqTec is prepared for DIN rail mounting in control cabinets.

Enclosure class: IPX0.

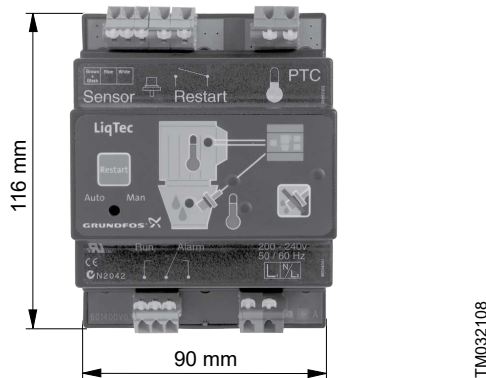

Pump type	Voltage [V]	LiqTec	Sensor 1/2"	Cable 5 m	Extensi on cable 15 m	Product number
CRE,	200-240	•	•	•	-	96556429
CRIE,	80-130	•	•	•	-	96556430
CRNE	-	-	-	-	•	96443676

- Available.
- Not available.

Kit, sensor cpl. MkII

This kit includes a sensor and cable only suitable for MGE motors.

Product	Product number
Sensor cpl. MkII with sensor and cable	99337830

Sensors

Sensor	Type	Supplier	Measuring range	Product number
Flowmeter	SITRANS FM MAGFLO MAG 5100 W	Siemens	1-5 m ³ (DN 25)	ID8285
	SITRANS FM MAGFLO MAG 5100 W		3-10 m ³ (DN 40)	ID8286
	SITRANS FM MAGFLO MAG 5100 W		6-30 m ³ (DN 65)	ID8287
	SITRANS FM MAGFLO MAG 5100 W		20-75 m ³ (DN 100)	ID8288
Temperature sensor	TTA (0) 25	Carlo Gavazzi	0-25 °C	96432591
	TTA (-25) 25		-25 to +25 °C	96430194
	TTA (50) 100		50-100 °C	96432592
	TTA (0) 150		0-150 °C	96430195
Accessory for temperature sensor. All with 1/2 RG connection	Protecting tube ∅9 x 50 mm			96430201
	Protecting tube ∅9 x 100 mm			96430202
	Cutting ring bush			96430203
Temperature sensor, ambient temperature	WR 52	tmg DK: Plesner	-50 to +50 °C	ID8295
Differential-temperature sensor	ETSD	Honsberg	0-20 °C	96409362
			0-50 °C	96409363

Note that all sensors have 4-20 mA signal output.

Grundfos Vortex Flow sensor, VFI

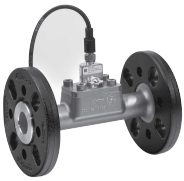
Grundfos Vortex Flow sensor, VFI ³⁰⁾	Type	Flow range [m ³ /h]	Pipe connection	O-ring		Connection type		Product number	
				EPDM	FKM	Cast-iron flange	Stainless-steel flange		
	VFI 1.3-25 DN32 020 E	1.3 - 25	DN 32	•		•		97686141	
	VFI 1.3-25 DN32 020 F				•		•	97686142	
	VFI 1.3-25 DN32 020 E				•			•	97688297
	VFI 1.3-25 DN32 020 F					•		•	97688298
	VFI 2-40 DN40 020 E	2 - 40	DN 40	•		•		97686143	
	VFI 2-40 DN40 020 F				•		•	97686144	
	VFI 2-40 DN40 020 E				•			•	97688299
	VFI 2-40 DN40 020 F					•		•	97688300
	VFI 3.2-64 DN50 020 E	2 - 64	DN 50	•		•		97686145	
	VFI 3.2-64 DN50 020 F					•	•	97686146	
	VFI 3.2-64 DN50 020 E				•			•	97688301
	VFI 3.2-64 DN50 020 F					•		•	97688302
VFI 5.2-104 DN65 020 E	5.2 - 104	DN 65	•		•		97686147		
VFI 5.2-104 DN65 020 F					•	•	97686148		
VFI 5.2-104 DN65 020 E				•			•	97688303	
VFI 5.2-104 DN65 020 F					•		•	97688304	
VFI 8-160 DN80 020 E	8 - 160	DN 80	•		•		97686149		
VFI 8-160 DN80 020 F					•	•	97686150		
VFI 8-160 DN80 020 E				•			•	97688305	
VFI 8-160 DN80 020 F					•		•	97688306	
VFI 12-240 DN100 020 E	12 - 240	DN 100	•		•		97686151		
VFI 12-240 DN100 020 F					•	•	97686152		
VFI 12-240 DN100 020 E				•			•	97688308	
VFI 12-240 DN100 020 F					•		•	97688309	

- Sensor tube with sensor, sensor tube of 1.4408 and sensor of 1.4404
- 4-20 mA output signal
- 2 flanges
- 5 m cable with M12 connection in one end
- quick guide.

³⁰⁾ For more information about the VFI sensor, see the Grundfos Direct Sensors™ data booklet, publication number 97790189 in Grundfos Product Center at www.grundfos.com.

Grundfos pressure sensor kits

Content	Liquid temperature	Pressure [bar]	Product number
Grundfos pressure transmitter, type ISP44, with 2.5 m cable. Connection: G 1/2 A (DIN 16288 - B6kt) Quick guide	-40 to +100 °C ³¹⁾	0-4	92618271
		0-6	92652122
		0-10	92652150
		0-16	92652152
		0-25	92618276

³¹⁾ Liquid temperature ranges from -40 to +130 °C at ambient temperatures up to 25 °C.

DPI differential-pressure sensor kit

Content	Pressure [bar]	Product number
1 sensor incl. 0.9 m screened cable (7/16" connections)	0 - 0.6	96611522
1 original DPI bracket for wall mounting	0 - 1.0	96611523
1 Grundfos bracket for mounting on motor	0 - 1.6	96611524
2 M4 screws for mounting of sensor on bracket	0 - 2.5	96611525
1 M6 screw (self-cutting) for mounting on MGE 90/100	0 - 4.0	96611526
1 M8 screw (self-cutting) for mounting on MGE 112/132	0 - 6.0	96611527
3 capillary tubes (short/long)		
2 fittings (1/4" - 7/16")		
5 cable clips (black)		
Installation and operating instructions (00480675)	0-10	96611550
Service kit instructions.		

Adjustable anti-vibration feet

Adjustable anti-vibration feet



TM043245

The adjustable support foot reduces any vibrations from the system to the floor, allowing the system to be height-adjusted by ± 20 mm.

Description	Pump type	Product number
1 pcs. anti-vibration foot	CR(I)E 3 and 5	96412344
	CR(I)E 10 to 20	96412345
	CRE 32 to 95	96412347

Remote controls

Grundfos GO

Use Grundfos GO for the following types of wireless communication with the pump:

- infrared
- radio
- Bluetooth.

MGE 0.37 to 11 kW

These motors will connect to the pump through wireless infrared or radio communication.

MI 301

MI 301 is a module with built-in infrared and radio communication. It is required for Grundfos GO communication. MI 301 can be used together with Android or iOS-based smart devices with a Bluetooth connection. MI 301 has a rechargeable Li-ion battery and must be charged separately.



TM053890

MI 301

Supplied with the product:

- Grundfos MI 301
- sleeve
- battery charger
- quick guide.

Product numbers

Grundfos GO variant	Product number
Grundfos MI 301	98046408

MGE 15 to 26 kW

These motors will connect to the pump via Bluetooth (BLE).

Related information

- [TOPIC NOT IN MAP (empty topicRef)]
href=concept-x1jwf0c.dita

CIM communication interface modules

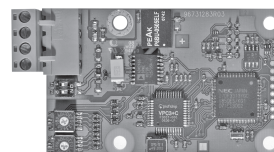

GRA6121

Grundfos CIM communication interface module

The CIM modules enable communication of operating data, such as measured values and setpoints, between the pumps and a building management system. The CIM modules are add-on communication modules which are fitted in the terminal box of the pumps.

Note that CIM modules must be fitted by authorised persons.

We offer the following CIM modules:

CIM 100

For communication via LONWorks.

CIM 150

For communication via PROFIBUS DP.

CIM 200

For communication via Modbus RTU.

CIM 300

For communication via BACnet MS/TP.

CIM 500

Ethernet module for communication via PROFINET, Modbus TCP, BACnet IP, EtherNet/IP GRM IP, Grundfos iSOLUTIONS Cloud.

Available CIM modules

Description	Fieldbus protocol	Product number
CIM 100	LONWorks	96824797
CIM 150	PROFIBUS DP	96824793
CIM 200	Modbus RTU	96824796
CIM 300	BACnet MS/TP	96893770
CIM 500	Ethernet	98301408
Antenna (puc)	3G/4G	99518079

For further information about data communication via CIM modules and fieldbus protocols, see the CIM documentation available in Grundfos Product Center at www.grundfos.com.

13. Variants

Different variants are available on request.

Although the Grundfos CRE, CRIE, CRNE product range offers a number of pumps for different applications, customers require specific pump solutions to satisfy their needs. See the following documents:

- Grundfos "CR Custom-built pumps" data booklet
- Grundfos "CRN high pressure" data booklet.

Find below the range of options available for customising the CRE pumps to meet the customers' demands.

Contact Grundfos for further information or for requests other than the ones mentioned below.

Motors

Variant	Description
Oversize motor	Ambient temperatures above 50 °C or installation at altitudes of more than 1000 metres above sea level require the use of an oversize motor, such as derating.
Low speed motor	We offer low speed (2000 rpm) motors.
IP66	The motor is completely dust-proof. The motor is protected against heavy seas or high-pressure water jets from any direction.
IT network (Earthing system)	This motor variant is designed for supply by an electric distribution system which has no connection to earth. This type of earthing system is called an IT network.
Advanced display	The pumps can be fitted with an HMI 301 operating panel as an option. The operating panel does not include a radio module.
Standard display	The pumps can be fitted with an HMI 201 operating panel as an option. The operating panel does not include a radio module.
Simple display	The pumps can be fitted with HMI 100 or HMI 101 operating panel as an option. HMI 100 includes a radio module. HMI 101 does not include a radio module. Grundfos GO is required to configure and set the pump.
Standard functional module (FM 200)	We offer FM 200 as an alternative to FM 300, fitted as standard. FM 200 offers fewer in- and output options compared to FM 300. The module has these connections: <ul style="list-style-type: none"> • two analog inputs • two digital inputs or one digital input and one open-collector output • Grundfos Digital Sensor input and output • two signal relay outputs • GENIbus connection.

Shaft seals

Variant	Description
Shaft seal with FFKM O-ring	We recommend shaft seals with FFKM or FXM O-ring for applications where the pumped liquid may damage the standard O-ring material.
Seal with flush, quench seal	We recommend seals with flush/quench seals for applications involving crystallising, hardening or sticky liquids.
Air-cooled shaft seal system	We recommend air-cooled shaft seal systems for applications involving extremely high temperatures. No conventional mechanical shaft seal can withstand liquid temperatures of up to 180 °C for any length of time. To ensure a low liquid temperature around the standard shaft seal, the pump is fitted with a special air-cooled shaft seal chamber. No separate cooling is required.
Double seal with pressure chamber	We recommend double seals with pressure chamber for applications involving poisonous or explosive liquids. It protects the surrounding environment and the people working in the vicinity of the pump. It consists of two seals mounted in a back-to-back arrangement inside a separate pressure seal chamber. As the pressure in the chamber is higher than the pump pressure, leakage is prevented. A dosing pump or a special pressure intensifier generates the seal chamber pressure.
CR MAGdrive	Magnetically driven pumps for industrial applications. Key applications are industrial processes involving the handling of aggressive, environmentally dangerous or volatile liquids, for example organic compounds and solvents.

Pumps

Variant	Description
Horizontally mounted pump	For safety or height reasons, certain applications, for instance on ships, require the pump to be mounted in a horizontal position. For easy installation, the pump is fitted with brackets that support motor and pump.
Low-temperature pump	Exposed to temperatures down to -40 °C, coolant pumps may require neck rings with a different diameter in order to prevent impeller drag.
High-speed pump up to 47 bar	For high-pressure applications, we offer a unique pump capable of generating a pressure of up to 47 bar. The pump is fitted with a high-speed motor, type MGE. The direction of rotation is the opposite of that of standard pumps, and the chamber stack is turned upside-down, as a result of which the pumped liquid flows in the opposite direction.
High-pressure pump up to 47 bar	For high-pressure applications, we offer a unique double pump system capable of generating a pressure of up to 47 bar.
Low-NPSH pump (improved suction)	We recommend the Low-NPSH pump for boiler-feed applications where cavitation may occur due to poor inlet conditions.
Pump with bearing flange	The bearing flange is suitable for applications where the inlet pressure is higher than the maximum pressure recommended. The bearing flange increases the life of motor bearings. We recommend this pump for standard motors.
Pump for pharmaceutical and biotechnological applications	CRNE pumps designed for applications requiring the sterilisation and CIP capability of pipes, valves and pumps. (CIP = clean-in-place).

Connections and other variants

Variant	Description
Pipe connections	In addition to the wide range of standard flange connections, a 16 bar DIN standard clamping flange is available. Customised flanges are available according to specifications.
TriClamp connection	TriClamp connections are of a hygienic design with a sanitary coupling for use in the pharmaceutical and food industry.
Electropolished pump	To substantially reduce the risk of corrosion of the materials. For use in the pharmaceutical and food industry.

14. Grundfos Product Center

Online search and sizing tool to help you make the right choice.
 From the international view, you can select your specific country to view the product range available to you.
 International view: <https://product-selection.grundfos.com>

All the information you need in one place

Performance curves, technical specifications, pictures, dimensional drawings, motor curves, wiring diagrams, spare parts, service kits, 3D drawings, documents, system parts. The Product Center displays any recent and saved items - including complete projects - right on the main page.

Downloads

On the product pages, you can download installation and operating instructions, data booklets, service instructions, etc., in PDF format.

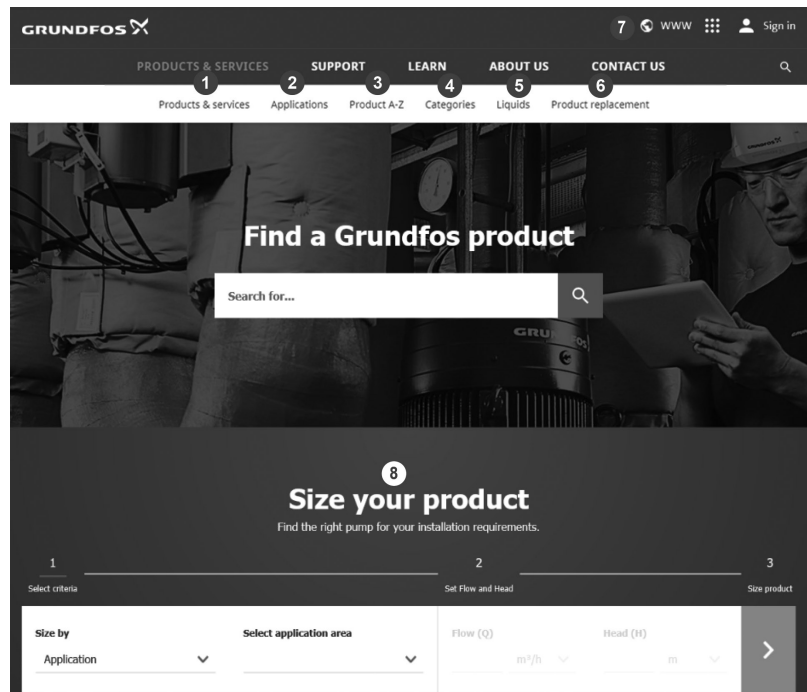

When you select your country, you will see the menus below. Note that some menus may not be available depending on the country.

Example: <https://product-selection.grundfos.com/uk>

Pos.	Description
1	Products & services enables you to find products and documents by typing a product number or name into the search field.
2	Applications enables you to choose an application to see how Grundfos can help you design and optimise your system.
3	Products A-Z enables you to look through a list of all the Grundfos products.
4	Categories enables you to look for a product category.
5	Liquids enables you to find pumps designed for aggressive, flammable or other special liquids.
6	Product replacement enables you to find a suitable replacement.
7	WWW enables you to select the country, which changes the language, the available product range and the structure of the website.
8	Sizing enables you to size a product based on your application and operating conditions.

Grundfos GO

Mobile solution for professionals on the GO!

Grundfos GO is the mobile tool box for professional users on the go. It is the most comprehensive platform for mobile pump control and pump selection, including sizing,

replacement and documentation. It offers intuitive, handheld assistance and access to Grundfos online tools, and it saves valuable time for reporting and data collection.



GET IT ON
Google play

Available on the
App Store

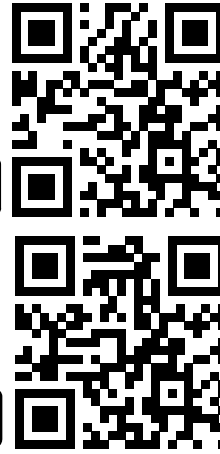

15. Document quality feedback

To provide feedback about this document, scan the QR code using your phone's camera or a QR code app.



FEEDBACK98423696

[Click here to submit your feedback](#)

98423696 06.2023

ECM: 1368720

GRUNDFOS Holding A/S
Poul Due Jensens Vej 7
DK-8850 Bjerringbro
Tel: +45 87 50 14 00
www.grundfos.com

GRUNDFOS 