



Modular electric deck oven

2 decks composition

serieP electric consists of one or more independent baking chambers and an optional leavening or stand. The baking surface is made of refractory bricks allowing the perfect heat distribution over the whole surface and making this oven particularly suitable for direct pizza baking on floor or on trays. In alternative to refractory brick, embossed stainless steel surface is available, especially indicated for bakery combined with steamer (optional). The baking chamber comes in two heights: 18 cm or 30 cm. Temperature management is electronic, power control of ceiling and floor is independent. The oven door is hinged at the bottom, with a tempered glass window to check the product during baking. The stand consists of a painted metal structure, while the leavening prover has a stainless steel structure, equipped with a heating thermostat. The leavening prover can reach the maximum temperature of 65°C (149°F), whereas the maximum temperature of the baking chamber is 450°C (842°F).



OPERATION

- Heated by armoured heating elements
- Electronic temperature management with independent adjustment of ceiling and floor
- Maximum temperature reached 450°C (842°F)
- Continuous temperatures monitoring in baking chamber by thermocouple
- Vapour ducting using manual butterfly valve

CONSTRUCTION

- Structure made in folded stainless steel
- Side panels in painted sheet metal
- Hood in stainless steel
- Steam duct in stainless steel plate
- Stainless steel door, tempered glass
- Aluminated steel top and side structure
- Dual halogen lighting
- Rock wool heat insulation

ACCESSORIES

- Leavening prover on wheels height 600, 800mm
- Stand with wheels height 600, 800, 950mm
- Leavening with humidifier 250W
- Steamer
- Spacer element height 300mm
- Refractory brick or buckle plate surface
- Additional tray holder guides for compartment and stand
- Motor for hood vapours extraction 500 m3/h
- Self-condensing hood
- Frontless hood

INTERNAL BAKING DIMENSIONS

Internal height	180-300mm
Internal depth	830mm
Internal width	605mm
Baking surface	0,5m ²

STANDARD EQUIPMENT

- 20 customizable programs
- Timer
- Economizer
- Independent maximum temperature safety device

TOP VIEW

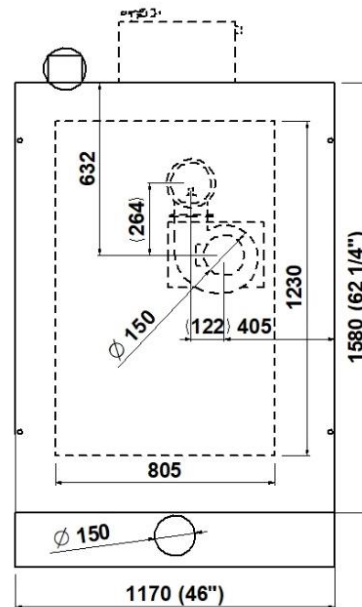

1 baking chamber height 18cm
(assembled with stand height 950mm)

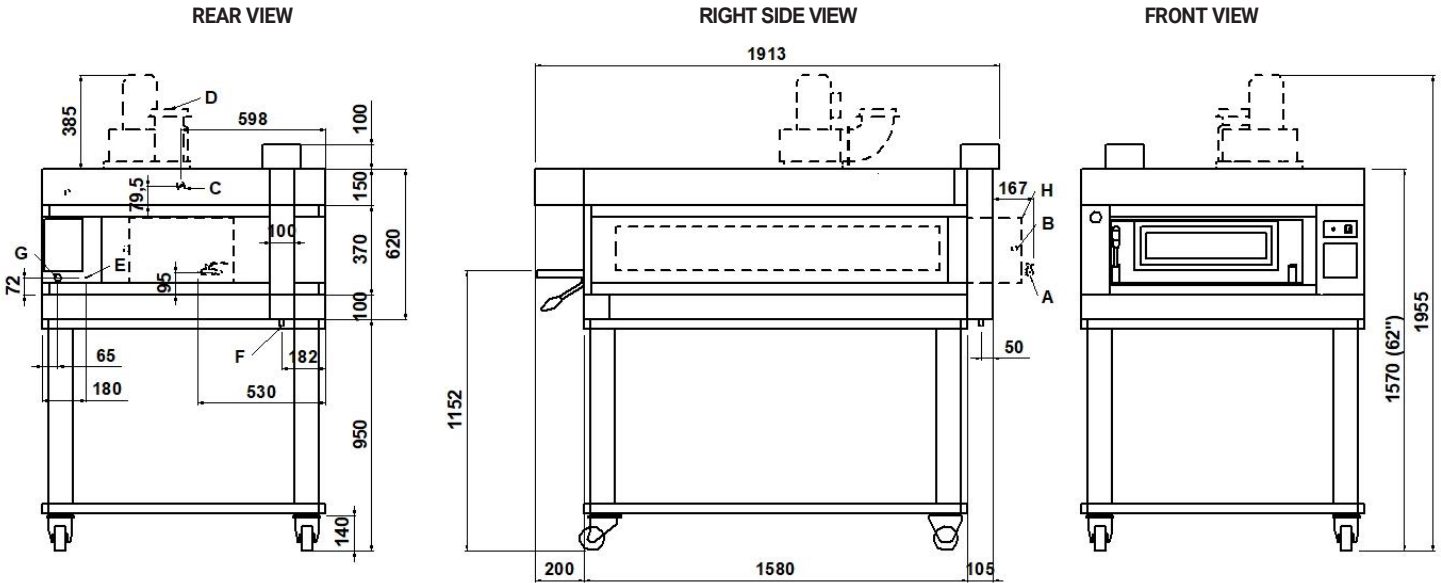

NOTE: The dimensions indicated in the views are in millimeters.

A Ø8 steamer water outlet	B 3/4" male steamer water inlet	C Ø16 hood condensate exhaust	D Ø150 steam exhaust
E M6 equipotential screws	F Ø12 condensate exhaust	G fairleads	H Steamer 1600W (see data sheet)

DIMENSIONS

External height	620mm
External depth	1941mm
External width	1170mm
Weight	211kg

SHIPPING INFORMATION

Packed in wooden crate	
Height	870mm
Depth	2141mm
Width	1370mm
Weight	(211+50)kg

FEEDING AND POWER

Standard feeding	V208 3ph
Feeding on request	V230 1ph
Frequency	50/60Hz
Max power	11kW
*Average power cons	5,5kWh

TOTAL BAKING CAPACITY

Tray (600x400)mm	4
Pizza diameter 300mm	9
Pizza diameter 450mm	3

When combined with leavening compartment or stand:	
Max height	1820mm
Max weight	(305+60)kg

No cord set supplied	
Power supply (optional prover)	
A.C. V230 1ph 60 Hz	
Max power	1,5kW
*Average power cons	0,8kWh
Conn. Cable type H07RN-F 3x1,5mm ²	



2 baking chambers height 18cm
(assembled with prover height 800mm)

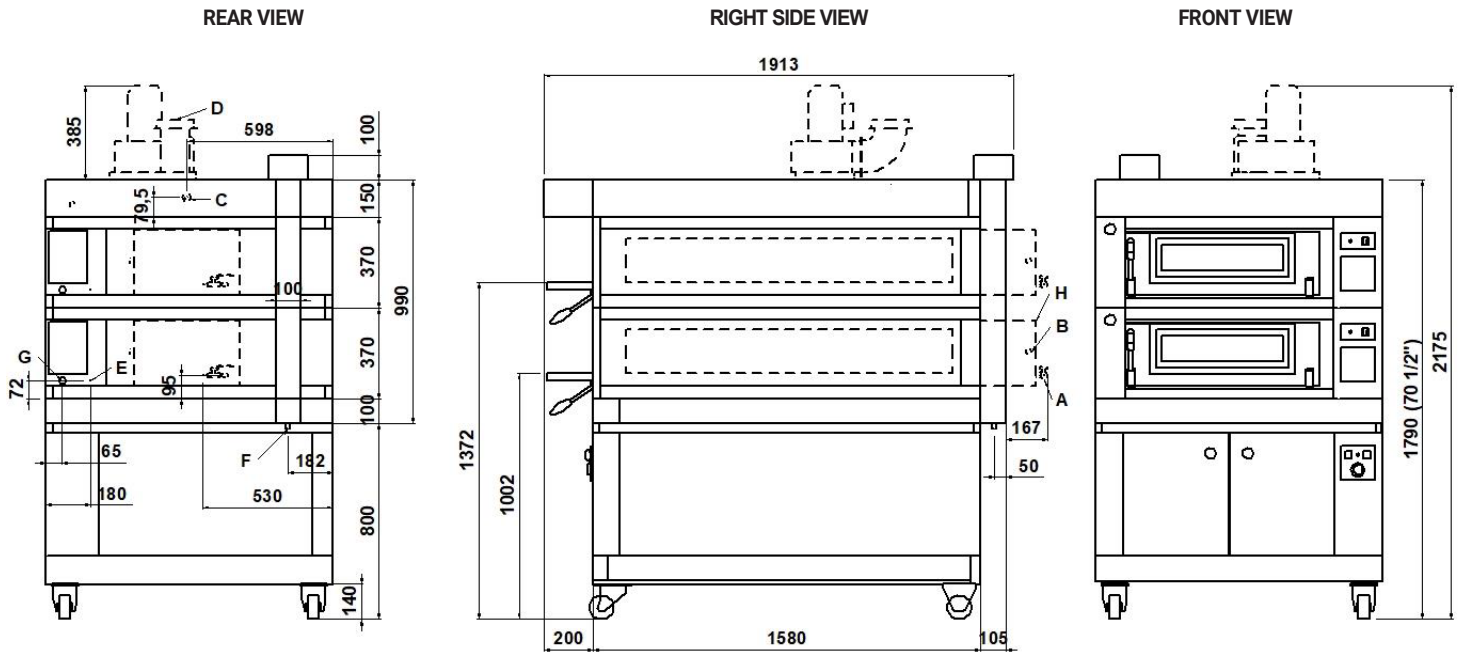

NOTE: The dimensions indicated in the views are in millimeters.

A Ø8 steamer water outlet	B 3/4" male steamer water inlet	C Ø16 Hood condensate exhaust	D Ø150 steam exhaust
E M6 equipotential screws	F Ø12 condensate exhaust	G fairleads	H Steamer 1600W (see data sheet)

DIMENSIONS

External height	990mm
External depth	1941mm
External width	1170mm
Weight	347kg

SHIPPING INFORMATION

Packed in wooden crate	
Height	1240mm
Depth	2141mm
Width	1370mm
Weight	(347+60)kg

FEEDING AND POWER

Standard feeding	V208 3ph
Feeding on request	V230 1ph
Frequency	50/60Hz
Max power	22kW
*Average power cons	11kWh

TOTAL BAKING CAPACITY

Tray (600x400)mm	8
Pizza diameter 300mm	18
Pizza diameter 450mm	6

When combined with leavening compartment or stand:	
Max height	2200mm
Max weight	(441+70)kg

No cord set supplied	
Power supply (optional prover)	
A.C. V230 1ph 60 Hz	
Max power	1,5kW
*Average power cons	0,8kWh
Conn. Cable type H07RN-F 3x1,5mm ²	



3 baking chambers height 18cm
(assembled with prover height 600mm)

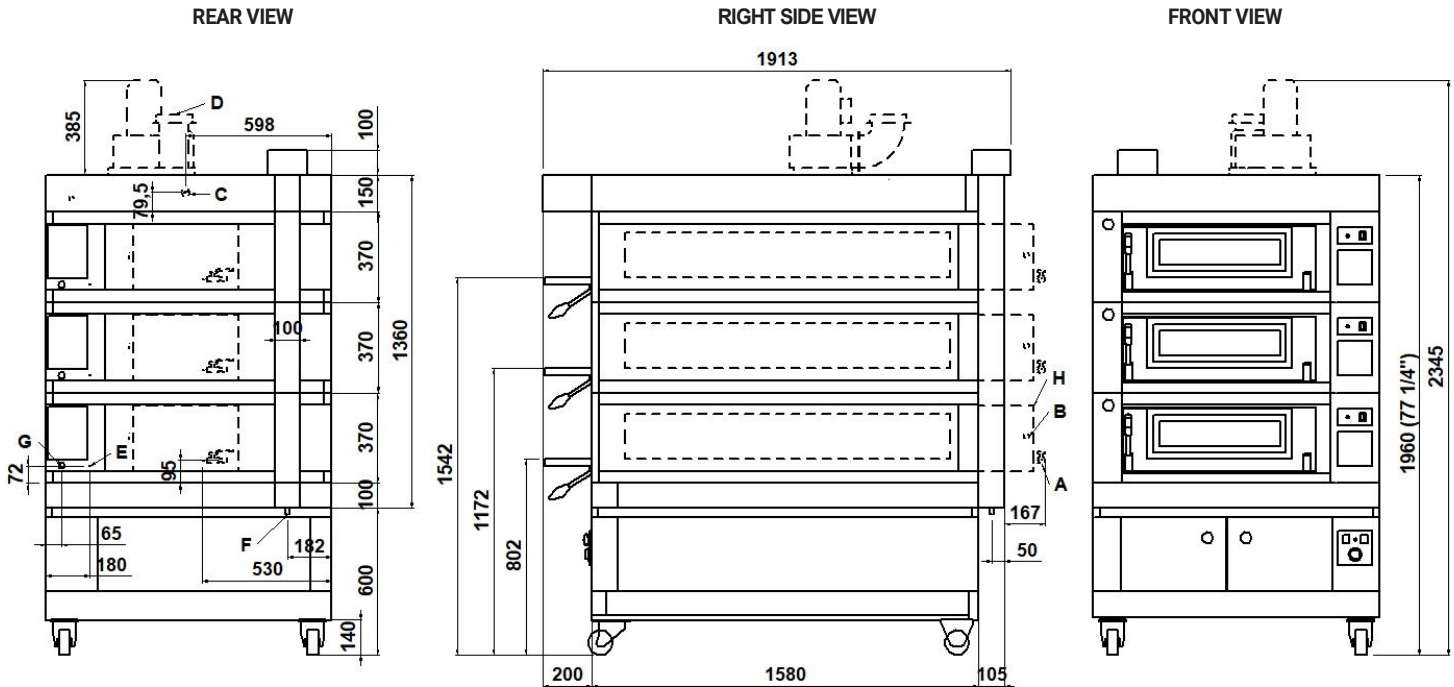

NOTE: The dimensions indicated in the views are in millimeters.

A Ø8 steamer water outlet	B 3/4" male steamer water inlet	C Ø16 Hood condensate exhaust	D Ø150 steam exhaust
E M6 equipotential screws	F Ø12 condensate exhaust	G fairleads	H Steamer 1600W (see data sheet)

DIMENSIONS

External height	1360mm
External depth	1941mm
External width	1170mm
Weight	483kg

SHIPPING INFORMATION

Packed in wooden crate	
Height	1610mm
Depth	2141mm
Width	1370mm
Weight	(483+70)kg

FEEDING AND POWER

Standard feeding	V208 3ph
Feeding on request	V230 1ph
Frequency	50/60Hz
Max power	33kW
*Average power cons	16,5kWh

TOTAL BAKING CAPACITY

Tray (600x400)mm	12
Pizza diameter 300mm	27
Pizza diameter 450mm	9

When combined with leavening compartment or stand:	
Max height	2560mm
Max weight	(570+80)kg

No cord set supplied

Power supply (optional prover)	
A.C. V230 1ph 60 Hz	
Max power	1,5kW
*Average power cons	0,8kWh
Conn. Cable type H07RN-F 3x1,5mm ²	



2 baking chambers height 18+30 cm
(assembled with prover height 800mm)

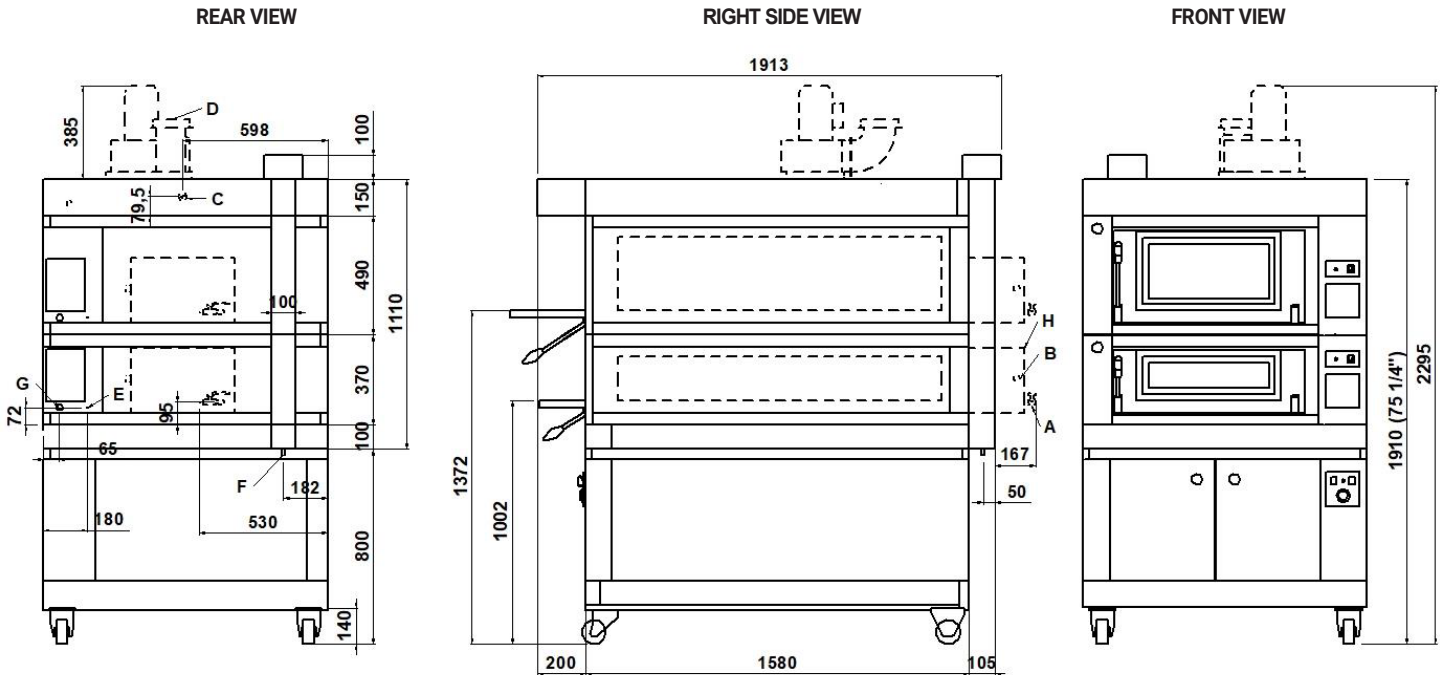

NOTE: The dimensions indicated in the views are in millimeters.

A Ø8 steamer water outlet	B 3/4" male steamer water inlet	C Ø16 Hood condensate exhaust	D Ø150 steam exhaust
E M6 equipotential screws	F Ø12 condensate exhaust	G fairleads	H Steamer 1600W (see data sheet)

DIMENSIONS

External height	1110mm
External depth	1941mm
External width	1170mm
Weight	370kg

SHIPPING INFORMATION

Packed in wooden crate	
Height	1360mm
Depth	2141mm
Width	1370mm
Weight	(370+60)kg

FEEDING AND POWER

Standard feeding	V208 3ph
Feeding on request	V230 1ph
Frequency	50/60Hz
Max power	22kW
*Average power cons	22kWh

TOTAL BAKING CAPACITY

Tray (600x400)mm	8
Pizza diameter 300mm	18
Pizza diameter 450mm	6

When combined with leavening compartment or stand:	
Max height	2320mm
Max weight	(470+70)kg

No cord set supplied

Power supply (optional prover)	
A.C. V230 1ph 60 Hz	
Max power	1,5kW
*Average power cons	0,8kWh
Conn. Cable type H07RN-F 3x1,5mm ²	



3 baking chambers height 18+18+30 cm
(assembled with stand prover 600mm)

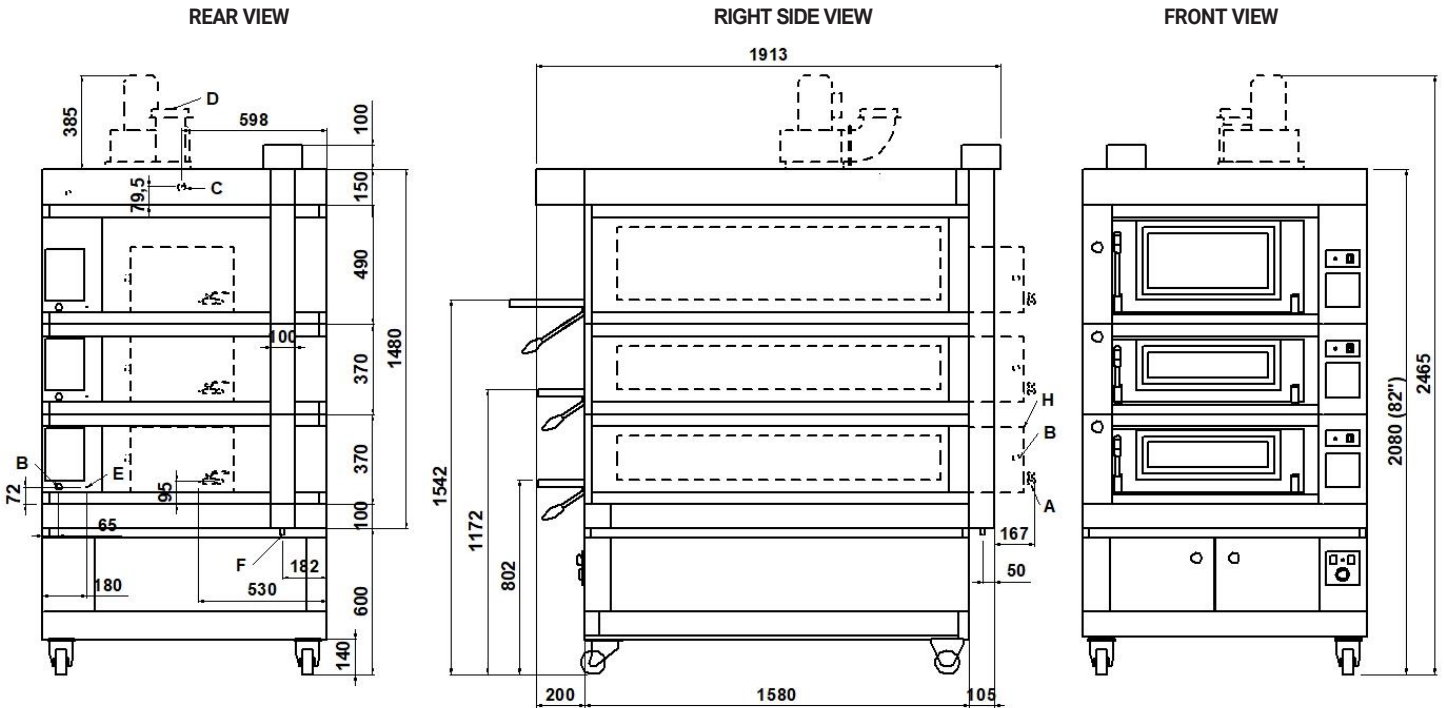

NOTE: The dimensions indicated in the views are in millimeters.

A Ø8 steamer water outlet	B 3/4" male steamer water inlet	C Ø16 Hood condensate exhaust	D Ø150 steam exhaust
E M6 equipotential screws	F Ø12 condensate exhaust	G fairleads	H Steamer 1600W (see data sheet)

DIMENSIONS

External height	1480mm
External depth	1941mm
External width	1170mm
Weight	505kg

SHIPPING INFORMATION

Packed in wooden crate	
Height	1730mm
Depth	2141mm
Width	1370mm
Weight	(505+70)kg

FEEDING AND POWER

Standard feeding	V208 3ph
Feeding on request	V230 1ph
Frequency	50/60Hz
Max power	33kW
*Average power cons	16,5kWh

TOTAL BAKING CAPACITY

Tray (600x400)mm	12	When combined with leavening compartment or stand:	
Pizza diameter 300mm	27		
Pizza diameter 450mm	9		
		Max height	2680mm
		Max weight	(595+80)kg

No cord set supplied	
Power supply (optional prover)	
A.C. V230 1ph 60 Hz	
Max power	1,5kW
*Average power cons	0,8kWh
Conn. Cable type H07RN-F 3x1,5mm ²	



P80
TECHNICAL DATA

SHIPPING INFORMATION H18		P80_1_18	P80_2_18	P80_3_18
Packed in wooden crate	Height	870mm	1240mm	1610mm
	Weight	(211+50)kg	(347+60)kg	(483+70)kg
When combined with prover or stand	Max. height	1820mm	2200mm	2560mm
	Max. weight	(305+60)kg	(441+70)kg	(570+80)kg
SHIPPING INFORMATION H30		P80_1_30	P80_2_30	P80_3_30
Packed in wooden crate	Height	990mm	1480mm	1970mm
	Weight	(225+50)kg	(375+60)kg	(525+70)kg
When combined with prover or stand	Max. height	1940mm	2440mm	2920mm
	Max. weight	(319+60)kg	(469+70)kg	(612+80)kg

FEEDING AND POWER (REFERRED TO 1 BAKING CHAMBER)	Max power	Pizzeria	kW	11
	*Average power consumption		kWh	5,5
	Max power	Pastry	kW	8,5
	*Average power consumption		kWh	4,3
	Max power	Boosted heating elements	kW	10,2
	*Average power consumption		kWh	5,1

