



Modular electric deck oven

2 decks composition

serieS is the most advanced and customizable oven in the world, ideal for **perfect baking of pizza, bakery, pastry, and gastronomy.**

Customize serieS choosing dimensions, number, and type of baking chamber, **material** for baking surface (refractory deck, or embossed steel deck, or bakingstone), door opening, Steel or Icon finish, and so much more. serieS meets all production needs thanks to specific and integrable baking chambers:

Multibake, Romanbake, Stonebake, Pastrybake e Steambake. Power consumption reduced by 35% and baking speed increased by 20% are the features that make serieS the evolution of baking; the professional oven for those who want to extend their business with a single tool



OPERATION

- Heated by highly performing armoured heating elements or spiral heating (stonebake)
- Temperature management using P.I.D. permit the automatic energy regulation to the quantity of the baked product Adaptive-Power® Technology
- Separated temperature management of ceiling and floor Dual-Temp® Technology
- Separated power management of ceiling and floor Dual-Power® Technology
- Automatic cleaning program for carbonization
- Maximum temperature reached 450°C
- Continuous temperatures monitoring in baking chamber by 2 thermocouples
- Vapour ducting using manual butterfly valve

CONSTRUCTION

- Structure made in folded stainless steel
- Side panels in painted sheet metal
- Channel hood
- Steam duct in stainless steel plate
- Stainless steel door, tempered glass element, door handle in stainless
- steel Aluminated steel top and side structure or refractory (stonebake)
- Refractory brick baking surface
- Dual halogen lighting
- Rock wool heat insulation

ACCESSORIES

- Leavening prover on wheels height 600, 800mm
- Stand with wheels height 400, 600, 800, 950, 1050mm
- Leavening with humidifier 250W
- Spacer element height 300mm
- Refractory brick or bakingstone or buckle plate surface
- Additional tray holder guides for compartment and stand
- Motor for hood vapours extraction 500 m3/h
- Max power optimizer (Fource®)
- Reverse door
- Lateral tool-holder for compartment
- Oversized hood, frontless hood
- Remote-Master® Technology for remote management and control

INTERNAL BAKING DIMENSIONS

Internal height	160-300mm
Internal depth	735mm
Internal width	1245mm
Baking surface	0,9m ²

STANDARD EQUIPMENT

- Color multilanguage display TFT 5"
- 100 customized programs with baking steps
- Eco-Standby BYTM Technology for break
- Power-Booster™ Technology for workload peaks
- Half-Load™ Technology for partial load
- Front and rear power balance Delta-Power™ Technology
- Customized Hotkey with recurring control
- Self-diagnosis with error message display
- Independent double baking Timer and Multitimer
- Weekly Timer with the possibility to program two lightings and two power off every day
- Independent security device of maximum temperature
- USB input and wi-fi module for sw update

TOP VIEW

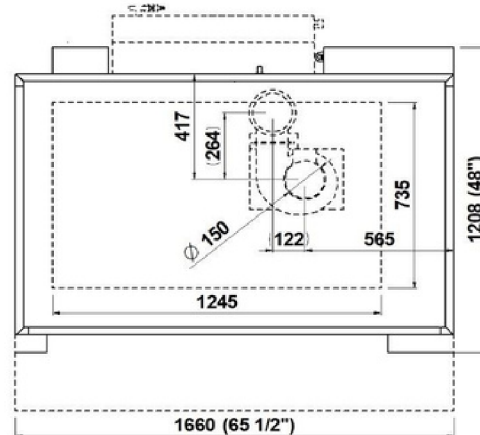

672 Dupont St, Toronto, ON, M6G 1Z6

Tel: 416.535.1555 Toll Free: 877.323.6226 Fax: 416.535.3843



1 baking chamber height 16cm
(assembled with stand height 950mm)

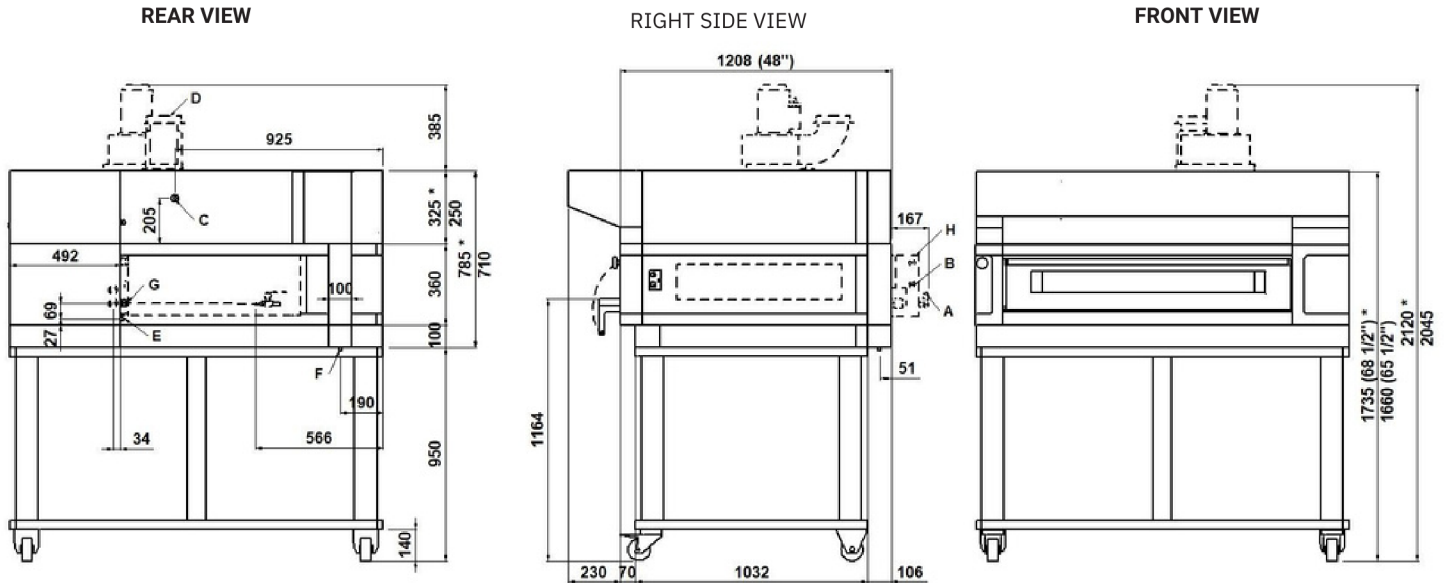

NOTE: The dimensions indicated in the views are in millimeters. *Dimensions refer to the oversized hood.

A B C Ø8 3/4" male Ø16	steamer water outlet	steamer water inlet	D Ø150 steam exhaust
E F G M6 Ø12 equipotential screws condensate exhaust fairleads			H Steamer 3200W (see data sheet)

DIMENSIONS

External height	820mm
External depth	1208mm
External width	1660mm
Weight	270kg

SHIPPING INFORMATION

Packed in wooden crate
Height 860mm
Depth 1643mm
Width 1870mm
Weight (270+50)kg

FEEDING AND POWER

Standard feeding V208 3ph
Feeding on request V230 1ph
Frequency 50/60Hz
Max power 12kW
*Average power cons 3,6kWh
No cord set supplied
Power supply (optional proofer)
A.C. V230 1ph 60 Hz
Max power 1,5kW
*Average power cons 0,8kWh

TOTAL BAKING CAPACITY

Tray (600x400)mm	3
Pizza diameter 350mm	6
Pizza diameter 450mm	3

When combined with leavening compartment or stand:
Max height 1810mm
Max weight (366+60)kg



2 baking chambers height 16cm
(assembled with proofer height 800mm)

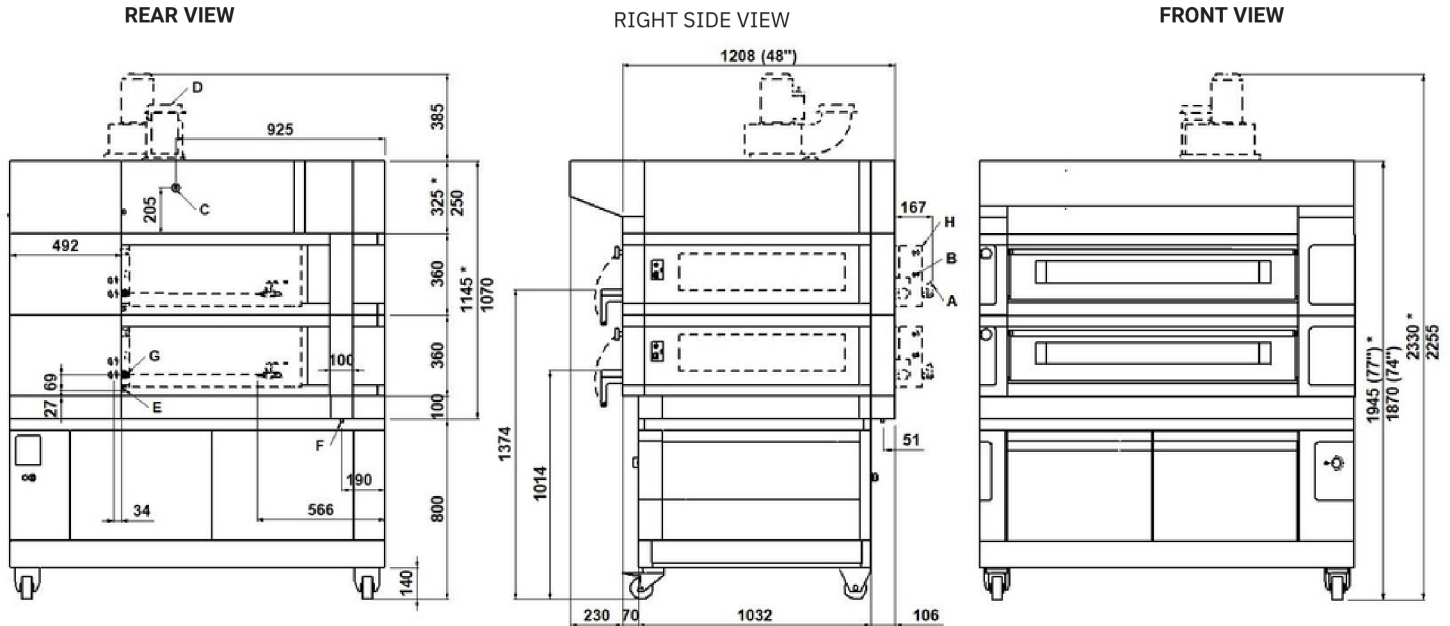

NOTE: The dimensions indicated in the views are in millimeters. *Dimensions refer to the oversized hood.

A B C Ø8 3/4" male Ø16	steamer water outlet	steamer water inlet	Hood condensate exhaust	D Ø150 steam exhaust
E F G M6 Ø12	equipotential screws	condensate exhaust	fairleads	H Steamer 3200W (see data sheet)

DIMENSIONS

External height	1180mm
External depth	1208mm
External width	1660mm
Weight	441kg

TOTAL BAKING CAPACITY

Tray (600x400)mm	6
Pizza diameter 350mm	12
Pizza diameter 450mm	6

SHIPPING INFORMATION

Packed in wooden crate
 Height 1220mm
 Depth 1643mm
 Width 1870mm
 Weight (441+60)kg

When combined with leavening compartment or stand:
 Max height 2020mm
 Max weight (537+70)kg

FEEDING AND POWER

Standard feeding V208 3ph Feeding on request V230 1ph
 Frequency 50/60Hz
 Max power 24kW
 *Average power cons 7,2kWh
 No cord set supplied
 Power supply (optional proofer)
 A.C. V230 1ph 60 Hz
 Max power 1,5kW
 *Average power cons 0,8kWh



3 baking chambers height 16cm
(assembled with prover height 600mm)

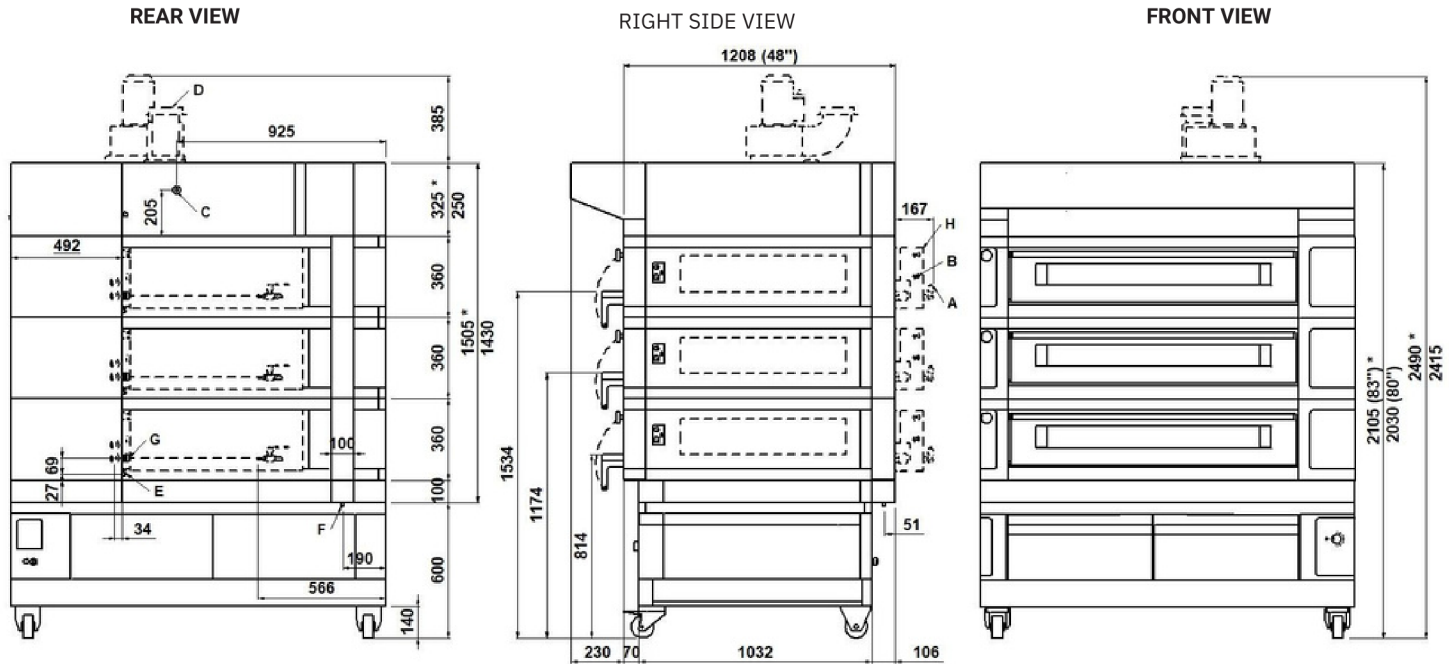

NOTE: The dimensions indicated in the views are in millimeters. *Dimensions refer to the oversized hood.

A B C Ø8 3/4" male Ø16	steamer water outlet	steamer water inlet	D Ø150 steam exhaust
E F G M6 Ø12 equipotential screws condensate exhaust fairleads			H Steamer 3200W (see data sheet)

DIMENSIONS

External height	1540mm
External depth	1208mm
External width	1660mm
Weight	612kg

TOTAL BAKING CAPACITY

Tray (600x400)mm	9
Pizza diameter 350mm	18
Pizza diameter 450mm	9

SHIPPING INFORMATION

Packed in wooden crate
Height 1580mm
Depth 1643mm
Width 1870mm
Weight (612+70)kg

When combined with leavening compartment or Stand:
Max height 2180mm
Max weight (699+80)kg

FEEDING AND POWER

Standard feeding V208 3ph Feeding onquest reqV240 1ph
Frequency 50/60Hz Max power 36kW
*Average power cons 10,8kWh
No cord set supplied Power supply (optional proofer)
A.C. V230 1N 50/60 Hz
Max power 1,5kW
*Average power cons 0,8kWh



2 baking chambers height 16+30 cm
(assembled with prover height 800mm)

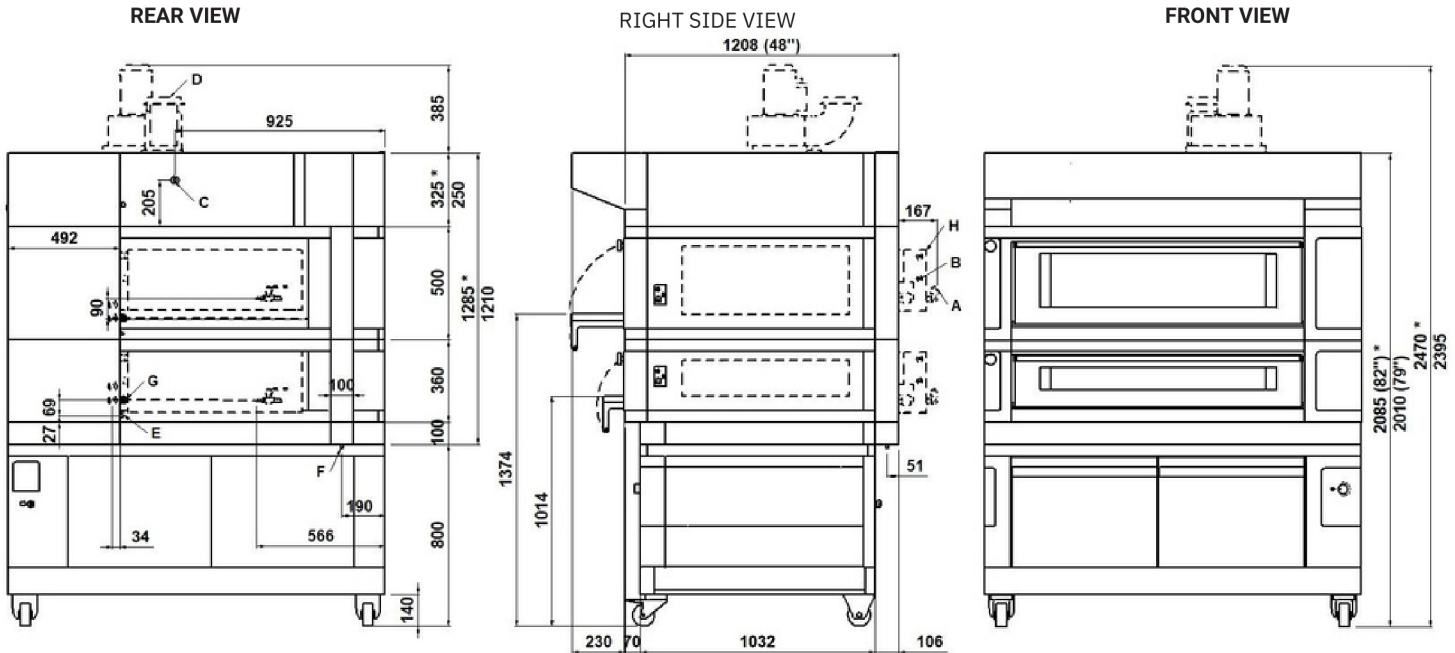

NOTE: The dimensions indicated in the views are in millimeters. *Dimensions refer to the oversized hood.

A B C Ø8 3/4" male Ø16	steamer water outlet steamer water inlet Hood condensate exhaust	D Ø150 steam exhaust
E F G M6 Ø12 equipotential screws condensate exhaust fairleads		H Steamer 3200W (see data sheet)

DIMENSIONS

External height	1320mm
External depth	1208mm
External width	1660mm
Weight	461kg

TOTAL BAKING CAPACITY

Tray (600x400)mm	
Pizza diameter 350mm	6
Pizza diameter 450mm	12
	6

SHIPPING INFORMATION

Packed in wooden crate
Height 13600mm
Depth 1643mm
Width 1870mm
Weight (461+60)kg

When combined with leavening compartment or Stand:
Max height 2160mm
Max weight (595+70)kg

FEEDING AND POWER

Standard feeding V208 3ph Feeding on request V230 1ph
Frequency 50/60Hz
Max power 24kW
*Average power cons 7,2kWh

No cord set supplied

Power supply (optional proofer)
A.C. V230 1ph 60 Hz
Max power 1,5kW
*Average power cons 0,8kWh



3 baking chambers height 16+16+30 cm
(assembled with prover height 600mm)

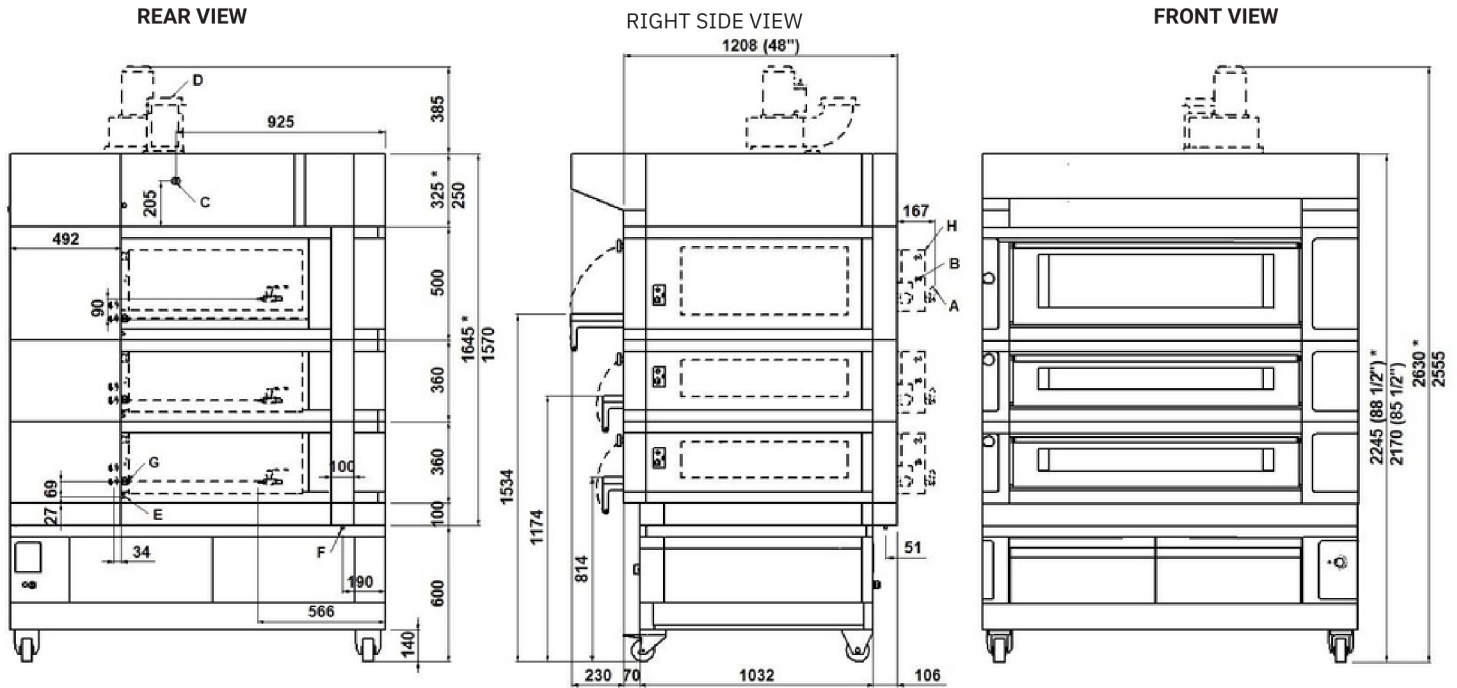

NOTE: The dimensions indicated in the views are in millimeters. *Dimensions refer to the oversized hood.

A B C Ø8 3/4" male Ø16	steamer water outlet	steamer water inlet	D Ø150 steam exhaust
E F G M6 Ø12 equipotential screws	condensate exhaust	fairleads	H Steamer 3200W (see data sheet)

DIMENSIONS

External height	1790mm
External depth	1208mm
External width	1660mm
Weight	652kg

TOTAL BAKING CAPACITY

Tray (600x400)mm	9
Pizza diameter 350mm	18
Pizza diameter 450mm	9

SHIPPING INFORMATION

Packed in wooden crate
 Height 1860mm
 Depth 1643mm
 Width 1870mm
 Weight (652+70)kg

When combined with leavening compartment or Stand:
 Max height 2180mm
 Max weight (740+80)kg

FEEDING AND POWER

Standard feeding V208 3ph Feeding onquest V230 1ph
 reqFrequency 50/60Hz
 Max power 36kW
 *Average power cons 10,8kWh
 No cord set supplied
 Power supply (optional proofer)
 A.C. V230 1ph 60 Hz
 Max power 1,5kW
 *Average power cons 0,8kWh



S120

TECHNICAL DATA

SHIPPING INFORMATION H16		S120E_1_16	S120E_2_16	S120E_3_16
Packed in wooden crate	Height	860mm	1220mm	1580mm
	Icon height	960mm	1320mm	1680mm
	Weight	(270+50)kg	(441+60)kg	(612+70)kg
When combined with prover or Stand	Max. height	1810mm	2020mm	2180mm
	Max. icon height	1910mm	2120mm	2280mm
	Max. weight	(366+60)kg	(537+70)kg	(699+80)kg
SHIPPING INFORMATION H30		S120E_1_30	S120E_2_30	S120E_3_30
Packed in wooden crate	Height	1000mm	1500mm	2000mm
	Icon height	1100mm	1600mm	2100mm
	Weight	(288+50)kg	(477+60)kg	(666+70)kg
When combined with prover or Stand	Max. height	1950mm	2400mm	2600mm
	Max. icon height	2050mm	2500mm	2700mm
	Max. weight	(384+60)kg	(573+70)kg	(753+80)kg
SHIPPING INFORMATION STONEBAKE		S120R_1_16	S120R_2_16	S120R_3_16
Packed in wooden crate	Height	860mm	1220mm	
	Icon height	960mm	1320mm	1580mm
	Weight	(324+50)kg	(549+60)kg	1680mm
When combined with prover or Stand	Max. height	1810mm	2020mm	(774+70)kg
	Max. icon height	1910mm	2120mm	2180mm
	Max. weight	(420+60)kg	(645+70)kg	2280mm

(861+80)kg

FEEDING AND POWER (REFERRED TO 1 BAKING CHAMBER)	Max power	Multibake	kW	12
	*Average power consumption		kWh	3,6
	Max power	Stonebake	kW	12
	*Average power consumption		kWh	3,6
	Max power	Romanbake		14,2
	*Average power consumption		kW	4,3
	Max power	Steambake	kWh	15,2
	*Average power consumption		kW	4,6
	Max power	Pastrybake	kWh	8,1
	*Average power consumption		kW	2,4
			kWh	

MAX TEMPERATURE	Multibake/Stonebake/Romanbake	°C/°F	450°C	842°F
	Steambake		350°C	662°F
	Pastrybake		270°C	518°F

