

PRESIDENT – THERMOSIPHONIC

MODEL:	ITEM:
FAEMA President Thermo 3 Buttons A2	F01-UP210D9BT999A
FAEMA President Thermo 3Buttons A2 AS	F01-UP210D9BTG9BA
FAEMA President Thermo 3Buttons A3	F01-UP310D9BT999A
FAEMA President Thermo 3Buttons A3 AS	F01-UP310D9BTG9BA

Date:

Project:







Location:

CUSTOMIZATION
 AVAILABLE

Unique design and new technology that never fails to assure great quality in every cup.



FEATURES

-  Temperature with Knobs
-  Smart Boiler
-  New Interface
-  New stainless steel portafilters
-  PGS
-  AutoSteam Milk 4 (optional)

Thermo Balance System with the NEW External Adjustable Temperature by group.

Choosing the most suited termic system is not easy. That is why the New FAEMA President offers 2 versions: **Thermosiphonic version** that guarantees the termic regulation of each group; and a **GTI version** with independent coffee boilers.



Even More Exclusive

Design and style make the NEW President a truly unique machine. However, it is made even more exclusive by the endless customization options. The thermosiphonic version is possible to customize the base and all the bodywork thanks to the easy-to-remove system.



Timeless style: the best coordination between the various stainless steel and black matt finishing for a unique character.



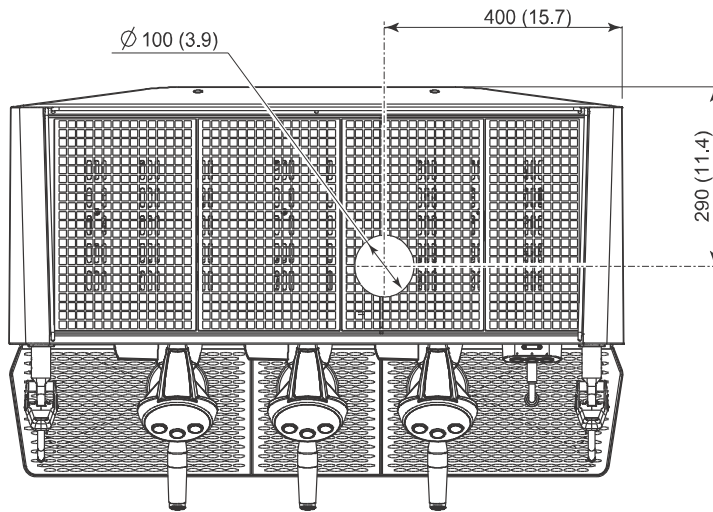
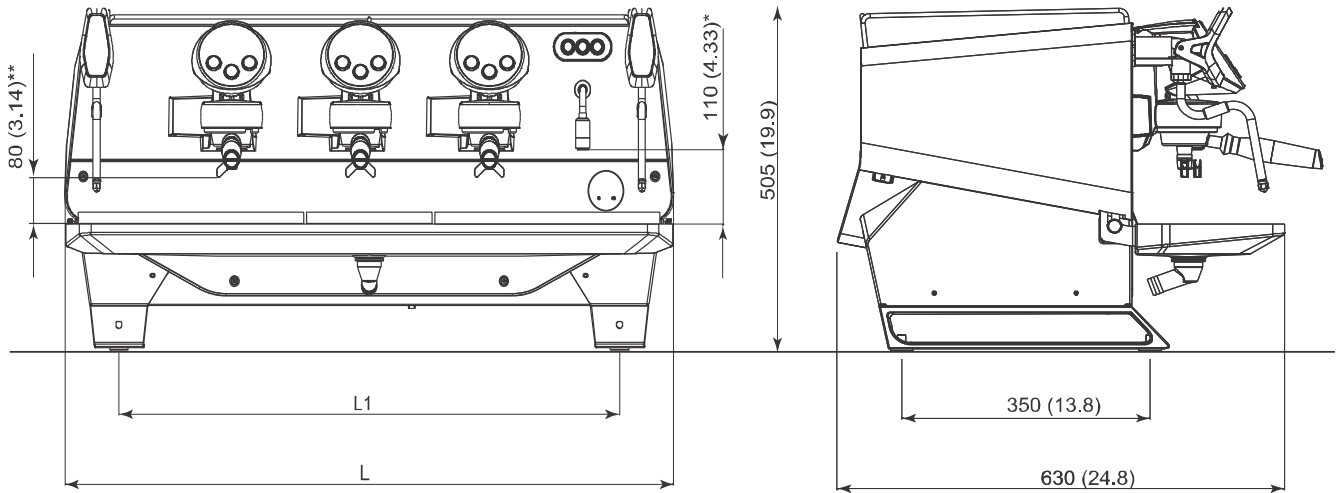

** pos.1= 80 (3.14)
pos.2= 115 (4.5)
pos.3= 140 (5.5)

* pos.1= 110 (4.33)
pos.2= 145 (5.7)
pos.3= 170 (6.7)

Customization Body & Base finishes



The machine Body (A)
Base Finishes (B)

(A) Steel or Chrome
(B) Matte Black

	THERMOSIPHONIC PRESIDENT		
	A2	A3	A4
Features			
Steam wands	2	2	2
Hot water wands	1	1	1
Hot water selections	3	3	3
Boiler capacity (L)	7	7	7
Electric cup warmer (3-temp settings)	✓	✓	✓
Technical Information			
Dimensions: Width x Depth x Height (mm)	820 x 630 x 505	1040 x 630 x 505	1260 x 630 x 505
Weight (kg)	77	90	113
Power at 220-240V~60Hz (W)	6200 - 7400	7500 - 8800	7500 - 8800
220-240V3~60Hz (W)			



A2- Group A3- Group

Receptacle



NEMA L6-30R

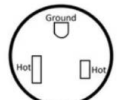

NEMA 6-50R
50 Amp
250 Volt

FAEMA Canada reserves the right to modify the characteristics of the products illustrated in this publication without prior notice for misprints and other errors. There may be colour deviations due to the printing process.