

SPRIZZA AUTOMATIC

Cold system pizza spinner

Date _____

Project _____

Location _____

| MODEL | ITEM CODE |
|--------------|-----------------|
| SPRIZZA 40 | S02-SPRIZZA40 |
| SPRIZZA 50 | S02-SPRIZZA50 |
| SPRIZZA AUTO | S02-SPRIZZAAUTO |



Models:

- SPRIZZA AUTOMATIC



General technical characteristics:

- Cold system for spreading the pizza dough;
- Patented micro-rolling system;
- Execution of the edge;
- Adjustable pizza thickness;
- Automatic start and stop;
- Capacity production 200-250 pcs/hr
- CE, ETL and EAC certification.

Optional accessories:

- Special tension.

Warranty:

- One year, ☒



Technical Data

Dimensions

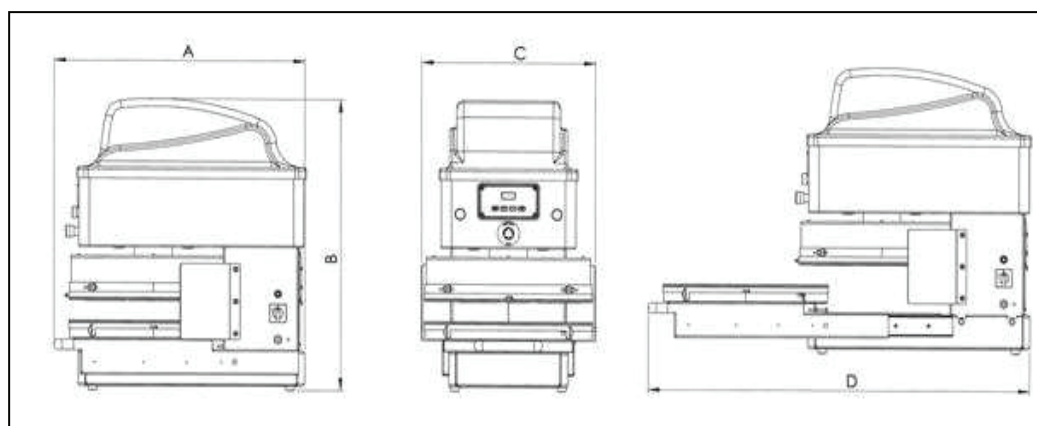

| MODEL | A | B | C | D | Power [kW] | Plate [mm] |
|----------------|-------------|-------------|-------------|--------------|------------|------------|
| SPZ AUTOMATICA | 724mm (29") | 768mm (30") | 503mm (20") | 1124mm (44") | 0.75 | 440 (17") |

Voltage:
230-400V/1-3/50Hz
(*Optional:* special voltages)

Transmission: belt.

Protections: emergency button.

Control panel: is positioned a display on the front of the machine , which serves to set the time and thickness . It has the ability to save 19 programs .

Shipping information

| Model | Net weight | Gross weight | |
|------------------|------------------|------------------|------------------|
| | | Pallet | Cage |
| SPZ AUTOMATIC | 120kg (705lb) | 130kg (286lb) | 170kg (374lb) |

Information on the packaging

| MODEL | Box on pallet | | Cage/Crate | |
|---------------|----------------------------|------------------------------|----------------------------|------------------------------|
| | Dimensions [mm] | Volume [m ³] | Dimensions [mm] | Volume [m ³] |
| SPZ AUTOMATIC | 750x900x1100 (29"x35"x43") | 0.74 (26.2 ft ³) | 980x830x1160 (38"x32"x45") | 0.94 (33.2 ft ³) |

