

SL50 - SILVER LINE

Spiral mixers with fixed bowl

Date	_____
Project	_____
Location	_____

MODEL	ITEM CODE
SL 50	S02-SL50



General technical characteristics:

- Two motors: 1 for the spiral and 1 for the bowl;
- Bowl inversion only in the first speed;
- Stainless steel bowl, spiral and shaft;
- Bowl jogs button;
- Security key for manual use;
- Bowl protection;
- Electromechanical control panel with 2 timers, (for the two spiral speeds);
- Machine mounted on wheels;
- Outer greasing system;
- CE, EAC and ETL certification.

Warranty:

- One year, ☒

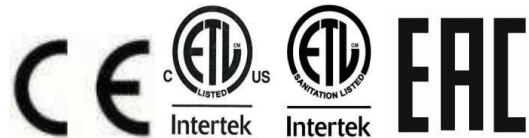

Optionals accessories:

- Programmable electronic control panel with 2 timers;
- PLC panel control;
- Special tensions;
- Drain bowl cap;
- Bowl and spiral control speed;
- Stainless steel version;
- Temperature probe;
- Scraper;
- Water dosing.



Technical Data

Dimensions

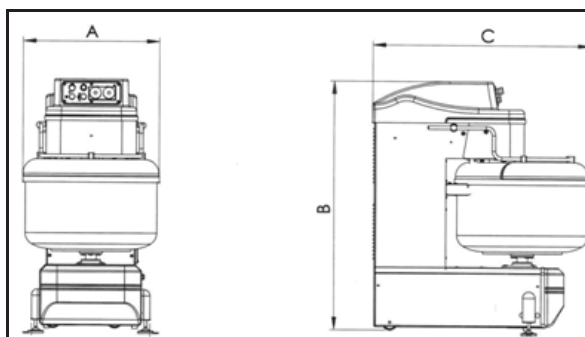

MODEL	A: Width	B: Height	C: Depth	Bowl (liters)	Power (kW)	Max flour (kg)
SL 50	530mm (22")	1140mm (45")	920mm (36")	67	1.9/2.6	30
SL 60	590mm (23")	1140mm (45")	950mm (37")	81	1.9/2.6	35
SL 60 PLUS	710mm (27")	1310mm (51")	1140mm (45")	100	2.0/3.7	40
SL 80	710mm (27")	1310mm (51")	1140mm (45")	130	2.0/3.7	50
SL 120	780mm (31")	1450mm (57")	1370mm (54")	170	2.6/4.8	75
SL 160	910mm (36")	1500mm (59")	1500mm (59")	230	5.9/10.3	100
SL 200	980mm (37")	1500mm (59")	1570mm (62")	290	5.9/10.3	125
SL 280	1100mm (43")	1500mm (59")	1600mm (63")	420	6.5/11.0	175

Voltage:

SL 60: 220V/1-3/60Hz

(Optional: special voltages)

Transmission: belts and chain.

Protections: protection cover , emergency button and hand anti – crushing.

Control panel: 2 manual (or digital) timers one for the first and one for the second speed . Command key for manual use and for reversing the rotation bowl.

Speeds: Bowl 13-15rpm; Spiral: 90-110 rpm (1st speed), 180-220rpm (2nd speed).

Shipping information

Model	Net weight	Gross weight	
		Pallet	Cage
SL 50	215kg (473lb)	225kg (496lb)	265kg (584lb)
SL 60	220kg (485lb)	230kg (507lb)	270kg (595lb)
SL 60 PLUS	320kg (705lb)	330kg (727lb)	370kg (815lb)
SL 80	330kg (727lb)	340kg (749lb)	380kg (837lb)
SL 120	490kg (1080lb)	500kg (1102lb)	540kg (1190lb)
SL 160	690kg (1521lb)	700kg (1543lb)	740kg (1631lb)
SL 200	750kg (1653lb)	-	800kg (1763lb)
SL 280	830kg (1829lb)	-	880kg (1940lb)

Information on the packaging

	Box on pallet		Cage/Crate	
	Dimensions [mm]	Volume [m ³]	Dimensions [mm]	Volume [m ³]
SL 50/60	940x650x1600 (37"x26"x63")	0.98 (34.6 ft ³)	1060x900x1550 (42"x35"x61")	1.48 (52.3 ft ³)
SL 60 PLUS	1370x840x1630 (54"x33"x64")	1.88 (66.4 ft ³)	1450x950x1610 (57"x37"x63")	2.22 (78.4 ft ³)
SL 80	1370x840x1630 (54"x33"x64")	1.88 (66.4 ft ³)	1450x950x1610 (57"x37"x63")	2.22 (78.4 ft ³)
SL 120	1370x840x1630 (54"x33"x64")	1.88 (66.4 ft ³)	1450x950x1610 (57"x37"x63")	2.22 (78.4 ft ³)
SL 160/200	-	-	1680x1130x1780 (66"x44"x70")	3.38 (119.4 ft ³)
SL 280	-	-	1980x1280x1780 (77"x50"x70")	4.52 (159.6 ft ³)

