



E65S

ICONIC.INNOVATIVE.POWERFUL



Authorized Dealer





THE KING OF GRINDERS



MAHLKÖNIG E65S

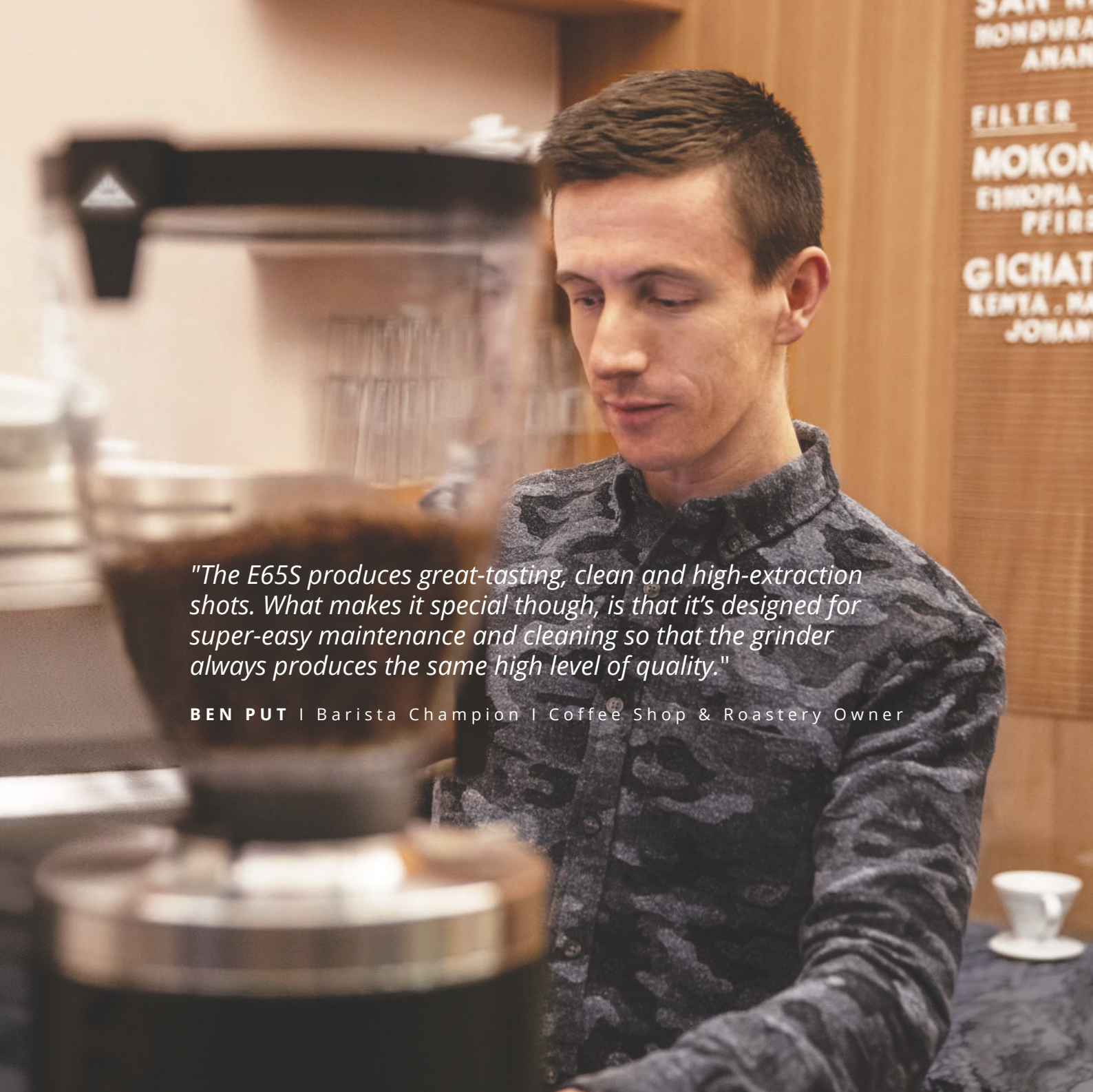

"The E65S produces great-tasting, clean and high-extraction shots. What makes it special though, is that it's designed for super-easy maintenance and cleaning so that the grinder always produces the same high level of quality."

BEN PUT | Barista Champion | Coffee Shop & Roastery Owner

MAHLKÖNIG E65S

DISCOVER THE NEXT GENERATION OF ESPRESSO GRINDING

The Mahlkönig E65S is the perfect synergy of proven premium espresso grinding technology and pioneering features, designed to meet the modern demands of coffee professionals around the globe.

"The King of Grinders" has equipped the new model with a multifunctional push and turn button, an innovative icon menu and presets for up to 6 individually programmable recipes. The modern slim body with a cutting-edge multi-color design features first class components and coatings for a premium look and feel.

But its design pleases more than just the eye: the E65S produces the most pleasant and silent grinding, while its overall construction is robust and well prepared to sustain high workloads. The perfect choice for coffee shops and restaurants.

E65S

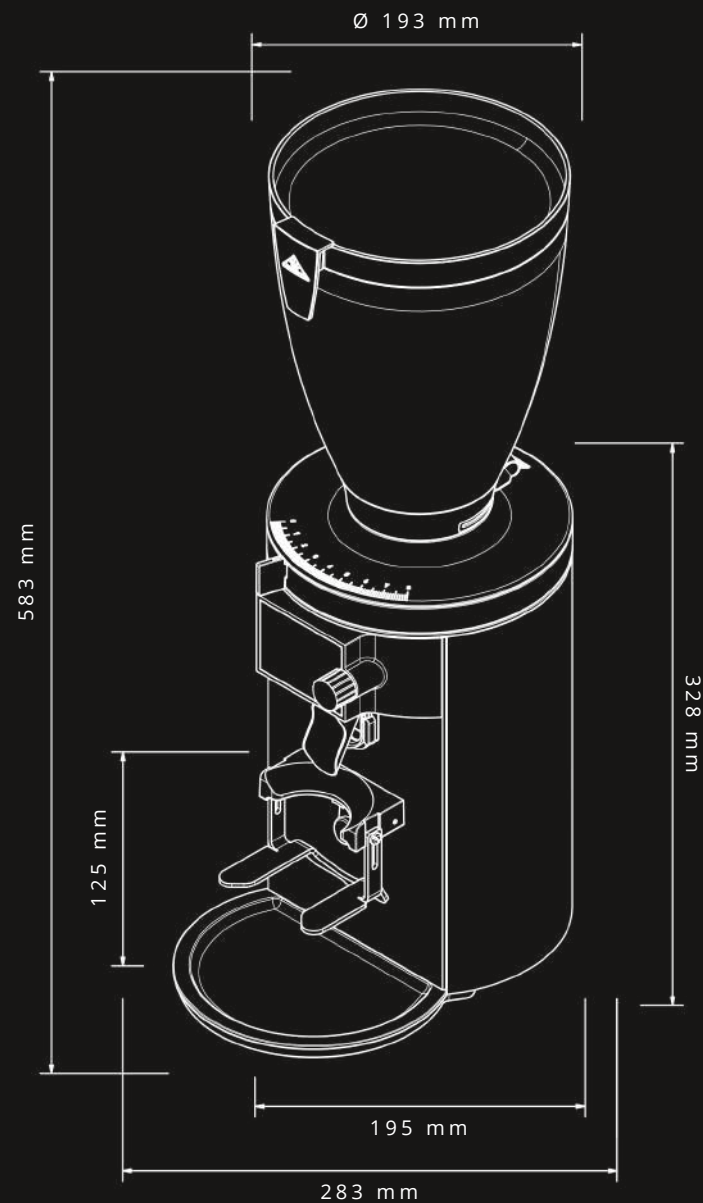

modern slim design

smart clip on lid

indestructible bean hopper

quick and easy grind adjustment

intuitive user interface

proven premium grinding profile

high performance motor

innovative temperature control

precise and impressively-consistent dosing

near-silent grinding

adjustable and removable spout

sturdy portafilter holder and knob

functional magnetic drip tray

small footprint



KEY FEATURES

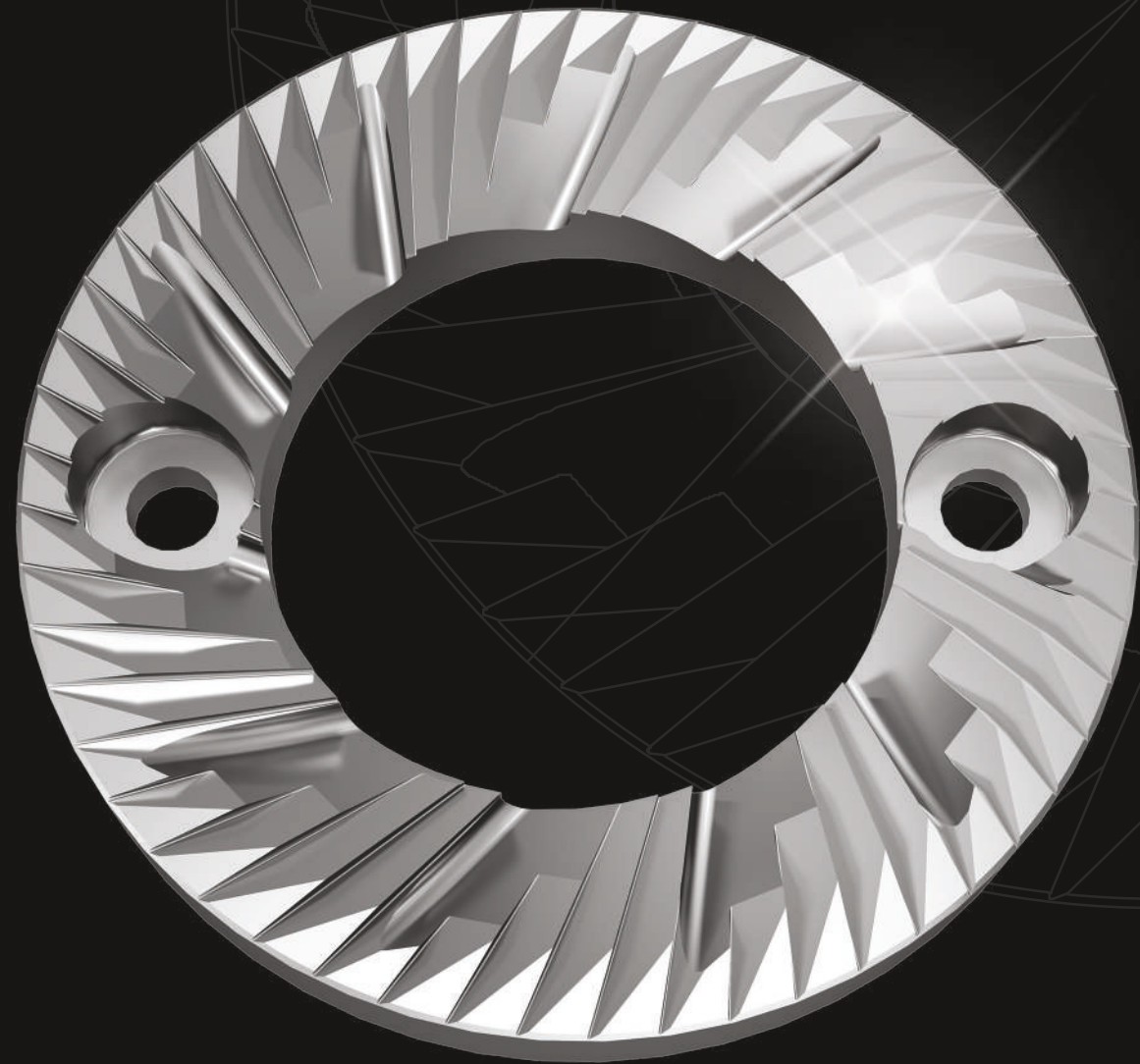

**At the heart of the grinder:
premium grinding technology.**

When it comes to manufacturing the centrepiece of grinding technology, we leave nothing to chance. Hence, we keep the engineering and production departments for our burrs exclusively in-house.

Whilst continuously analysing recent and upcoming market requirements, our engineers use their expertise and skills to shape the innovative spirit of Mahlkönig. Using the latest computer-controlled technology, each burr acquires its individual shape and finishing touch under the watchful eyes of our experienced production team in Hamburg.

For almost 100 years, Mahlkönig has been compiling a comprehensive catalogue of different tooth profiles and grinding surface patterns, allowing us to select the perfect set of espresso burrs for the E65S. Manufactured from high-quality hardened steel, each set of burrs lasts for approx. 1000 kg of beans, depending on the roast. The sophisticated design of the 65 mm burrs guarantees optimal particle size, allowing the espresso to release its full taste and aroma.



Precise and consistent dosing is the key to a steady in-cup quality.

The grinding chamber of the E65S cuts retention to a minimum, which not only avoids cross-contaminations of different varieties, but also ensures the most precise dosing consistency.

Extensive heavy-duty laboratory tests have shown that the E65S deviates by only 0.4 g during an extreme workload cycle of 100 shots straight.



CONSISTENT



PRECISE

Have the precious aroma of your beans protected by the innovative motor temperature control.

Mahlkönig's engineering team has equipped the motor of the E65S with a ground-breaking temperature control. The smart construction is designed to create an airflow taking in fresh air that cools down the motor continuously. An additional fan gets activated when the E65S is grinding higher loads, in order to prevent your espresso beans from suffering from any possible negative influence by rising temperatures.

Even under heavy-duty laboratory tests, where the E65S was used to grind 100 shots straight, the temperature of the ground coffee never reached the 50-degree mark.

The motor is designed to handle high workloads:

Max. nominal power	ON/OFF	Duty Cycle (DC)	Performance (DS*2 = 20 g)
220-240 V 50/60 Hz	5 s ON / 15 s OFF	25 % DC S3*1 (20 s)	3 DS*2/min
100 V 50/60 Hz	5 s ON / 25 s OFF	16.7 % DC S3*1 (30 s)	2 DS*2/min
110-127 V 60 Hz	4 s ON / 26 s OFF	13.3 % DC S3*1 (30 s)	2 DS*2/min

*1 S3: Intermittent periodic duty
*2 DS: Double shot



Pioneering grind-adjustment technology lets you set and keep the perfect degree of fineness.

The ultrafine thread inside the grind-adjustment mechanism of the E65S enables the utmost precision when it comes to obtaining the right degree of fineness for your espresso beans. The adjustment range spans 180 to 580 µm, whilst the 80 step indicating scale offers meticulous repeatability. An auto-lock system keeps the adjustment in place. However, to ensure the setting doesn't get changed unintentionally, there an additional dial on the back of the grinder to lock the perfect degree of fineness if required.

Our revolutionary spout, designed for perfectly-centred espresso grinding.

The re-designed spout adapts to every portafilter within seconds by being simply pushed or pulled into place. Made from specially selected anti-static material, honed into a uniquely effective shape, it allows the grounds to flow very fluffy into the portafilter.

Grinding has never sounded so good.

We all want our customers to fully enjoy espresso without disturbance. With this in mind, a team of Mahlkönig engineers and acoustics experts developed the body of the E65S with a strong focus on noise reduction and frequency optimization. The sturdy grinder housing, foam-insulated side covers and a special foil behind the front cover, all help to reduce and deepen the grinding sound to below 70 dB(A).



< 70 dB(A)





Changing perceptions: Large display for optimal control.

The E65S features a 61.2 mm color display for the most comfortable navigation through the settings, statistics and service intervals.

Set the dose with the ease of a push and a turn of a button.

The multifunctional push and turn button lets you navigate through the intuitive icon menu and set the timer within seconds. Offering up to 6 easily programmable recipes, the E65S is well-prepared for even the most varied menu. Once it's time to grind, you simply choose the dose you need, insert the portafilter and the E65S immediately serves the perfect shot of grounds.

Quality leaves nothing to chance.

The E65S software was designed to guarantee smooth workflows at the bar by featuring its preset service alerts and a variety of statistics. The alerts will notify you to clean the grinder with GRINDZ or to exchange the burrs, by calculating the ground volume history. Since a well-maintained grinder guarantees the best taste in every cup, the E65S software will make all the difference.

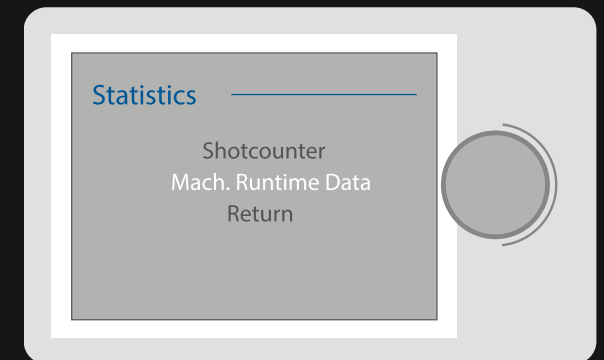



The perfect match for any espresso bar.

The slimline body design with its compact footprint brings outstanding grinding quality even to the smallest of bars. However, with its modern style and clean look the E65S can equally shine like a star on your spacious counter, demonstrating first-class grinding quality and modern design.

Whether you are in need of a premium espresso grinder to fit into a very small space or you are looking for an eye-catching highlight to complete your brewing stage: the E65S is made for you.

Polished aluminum, matte black

Polished aluminum, matte black & white



Absolutely indestructible: the bean hopper

The new ultra-robust bean hopper of the E65S is practically unbreakable. Relying on screws instead of adhesive, the bean hopper and adapter will never come apart during use and the integrated finger protection inside the bean hopper guarantees user safety. Simply fill it with up to approx. 1200 g of beans and start grinding. If required, two optional sizes of bean hopper are available - the smaller approx. 250 g unit or the larger approx. 1800 g version. The standard 1200 g hopper features our new smart clip on the lid that can be used to hold a note - for example, an information card for the customer to learn more about the coffee or brewing/recipe instructions to be kept in mind by the barista.

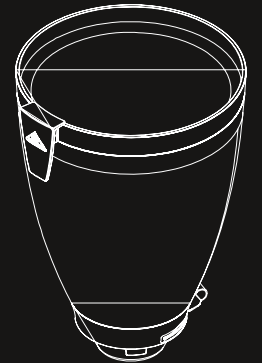

Perfectly adaptable: the portafilter holder

The rock steady portafilter holder is incredibly simple to adjust by loosening and tightening just two screws, allowing it to fit any portafilter with ease. Its sturdy stainless steel construction will neither bend nor bow. This, along with the robust start-stop button, guarantee trouble-free use, even during the busiest of rush hours.

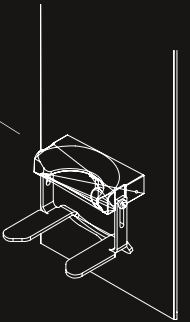

Clean bar counter: the drip tray

The drip tray with its optimal size, shape and position help to keep your bar clean and free from unwanted grounds. Held in place by two strong magnets it self-adjusts and easily slips into position, making it simple to detach, clean and put back into place.

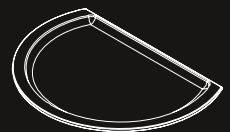

TECHNICAL DETAILS

Voltage // frequencies // phases // nominal power	220-240 V // 50/60 Hz // 1~ // 440 W 110-127 V // 60 Hz // 1~ // 580 W 100 V // 50/60 Hz // 1~ // 510 W
Idle speed	1400 rpm (50 Hz) 1700 rpm (60 Hz)
Burr diameter	65 mm
Burr material	Special steel
Average grinding capacity*	4-7 g/s
Bean hopper capacity	approx. 1200 g
Dimensions (w x h x d)	19,5 x 58,3 x 28,3 cm
Dimensions of packing (w x h x d)	69,7 x 28,7 x 44,5 cm
Net weight	11,2 kg
Gross weight	12,7 kg
Certifications	CE, CB, ETL Safety, ETL Sanitation
Standards	Conforms to IEC/EN 60335-1 except IPX1 IEC/EN 60335-2-64 except IPX1 Certified to Standard ANSI/UL 763 CSA C22.2 No. 195 NSF/ANSI 8
Standard colors	Polished aluminum, matte black Polished aluminum, matte black & white
Special equipment (bean hopper)	approx. 250 g or approx. 1800 g



*Depends on the grinding goods and the chosen degree of fineness. | All measured values under laboratory conditions.
Other electric specifications available on request. | Subject to change without prior notice.



08 | 2020

