



Modular electric deck oven

2 decks composition

Amalfi consists of one or more independent baking chambers and an optional leavening or stand. The baking chamber is entirely made of refractory bricks with coiled heating elements inside, allowing the perfect heat distribution over the whole surface. This oven is particularly suitable for directly pizza baking, specific for more delicate toppings and indicated for indirect baking on trays. Temperature management is electronic, power control of ceiling and floor is independent. The oven door is hinged at the bottom, with a tempered glass window to check the product during baking. The stand consists of a painted metal structure, while the leavening proofer has a stainless steel structure equipped with a heating thermostat. The leavening proofer can reach the maximum temperature of 149°F, whereas the maximum temperature of the baking chamber is 842°F.



OPERATION

- Heated by spiral heating elements
- Electronic temperature management with independent adjustment of ceiling and floor
- Maximum temperature reached 842°F
- Continuous temperatures monitoring in baking chamber by thermocouple
- Vapour ducting using manual butterfly valve

CONSTRUCTION

- Structure made in folded stainless steel
- Side panels in painted sheet metal
- Hood in stainless steel
- Steam duct in stainless steel plate
- Stainless steel door, tempered glass
- Refractory top and side structure
- Dual halogen lighting
- Rock wool heat insulation

ACCESSORIES

- Leavening proofer on wheels height 23 1/2", 31 1/2"
- Stand with wheels height 23 1/2", 31 1/2", 37 1/2"
- Spacer element height 11 13/16"
- Additional tray holder guides for compartment and stand
- Self-condensing hood
- Frontless hood

INTERNAL BAKING DIMENSIONS

Internal height	7"
Internal depth	45 1/4"
Internal width	43 1/2"
Baking surface	13,8ft ²

STANDARD EQUIPMENT

- 20 customizable programs
- Timer
- Economiser
- Independent maximum temperature safety device

TOP VIEW

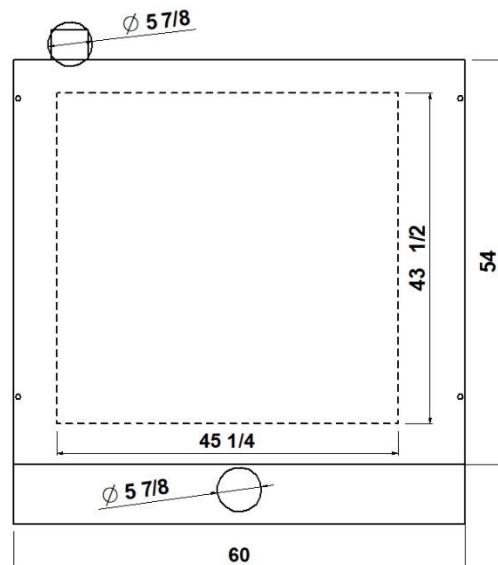

1 baking chamber height 7"
(assembled with stand height 37 1/2")

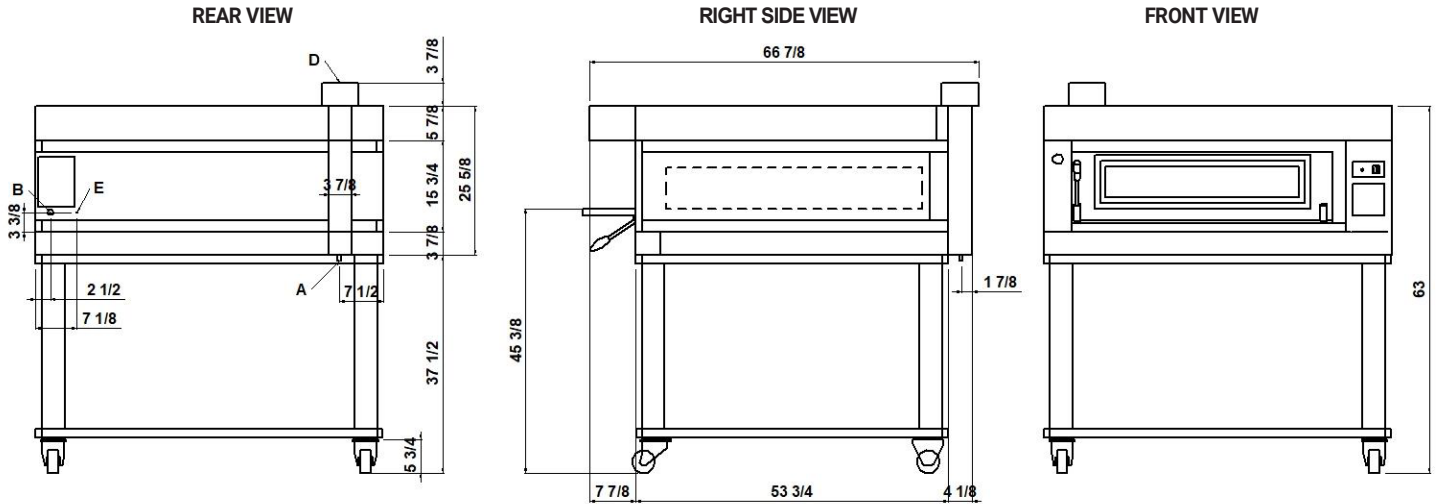

NOTE: The dimensions indicated in the views are in inches.

A	B	D	E
Ø 1/2"	fairleads	Ø 5 7/8"	M6
condensate exhaust		steam exhaust	equipotential screws

DIMENSIONS

External height	25 5/8" (650mm)
External depth	54" (1365mm)
External width	60" (1520mm)
Weight	781lb (354kg)

TOTAL BAKING CAPACITY

Tray 26"x18" (600x400)mm	4
Pizza diameter 12"	12
Pizza diameter 18"	5

SHIPPING INFORMATION

Packed in wooden crate

Height	36" (900mm)
Depth	76" (1930mm)
Width	68" (1720mm)
Weight	891lb (404kg)

When combined with leavening compartment or stand:

Max height	73" (1850mm)
Max weight	1244lb (564kg)

FEEDING AND POWER

Standard feeding	V208 3ph
Feeding on request	V240 1ph
Frequency	60Hz
Max power	13,7kW/DECK
*Average power cons	6,9kWh

No cord set supplied

Power supply (optional proofer)
A.C. V(208/240) 1ph 60 Hz

Max power	1,8kW
*Average power cons	0,9kWh



2 baking chambers height 7"
(assembled with proofer height 31 1/2")

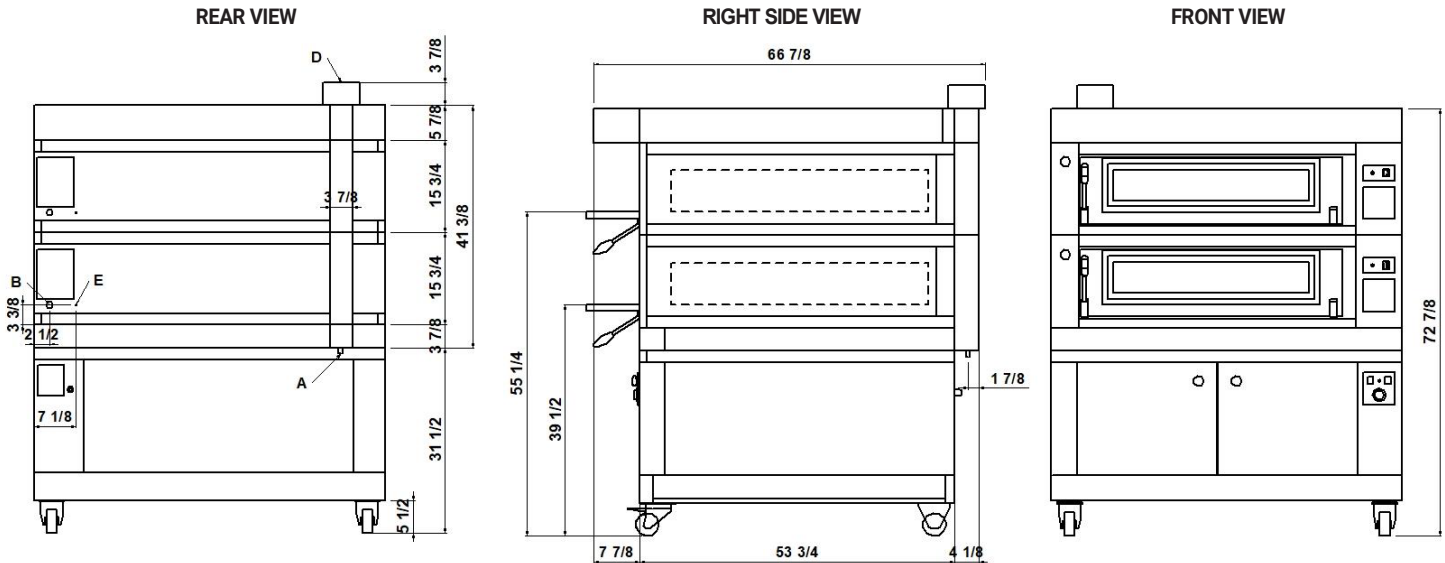

NOTE: The dimensions indicated in the views are in inches.

A Ø 1/2" condensate exhaust	B fairleads	D Ø 5 7/8" steam exhaust	E M6 equipotential screws
--	-----------------------	---------------------------------------	--

DIMENSIONS

External height	41 3/8" (1050mm)
External depth	54" (1365mm)
External width	60" (1520mm)
Weight	1336lb (606kg)

TOTAL BAKING CAPACITY

Tray 26"x18" (600x400)mm	8
Pizza diameter 12"	24
Pizza diameter 18"	10

SHIPPING INFORMATION

Packed in wooden crate

Height	51 1/2" (1300mm)
Depth	76" (1930mm)
Width	68" (1720mm)
Weight	1160lb (526kg)

When combined with leavening compartment or stand:

Max height	89" (2250mm)
Max weight	1845lb (836kg)

FEEDING AND POWER

Standard feeding	V208 3ph
Feeding on request	V240 1ph
Frequency	60Hz
Max power	13,7kW/DECK
*Average power cons	6,9kWh

No cord set supplied

Power supply (optional proofer)
A.C. V(208/240) 1ph 60 Hz

Max power	1,8kW
*Average power cons	0,9kWh



3 baking chambers height 7"

(assembled with proofer height 23 1/2")

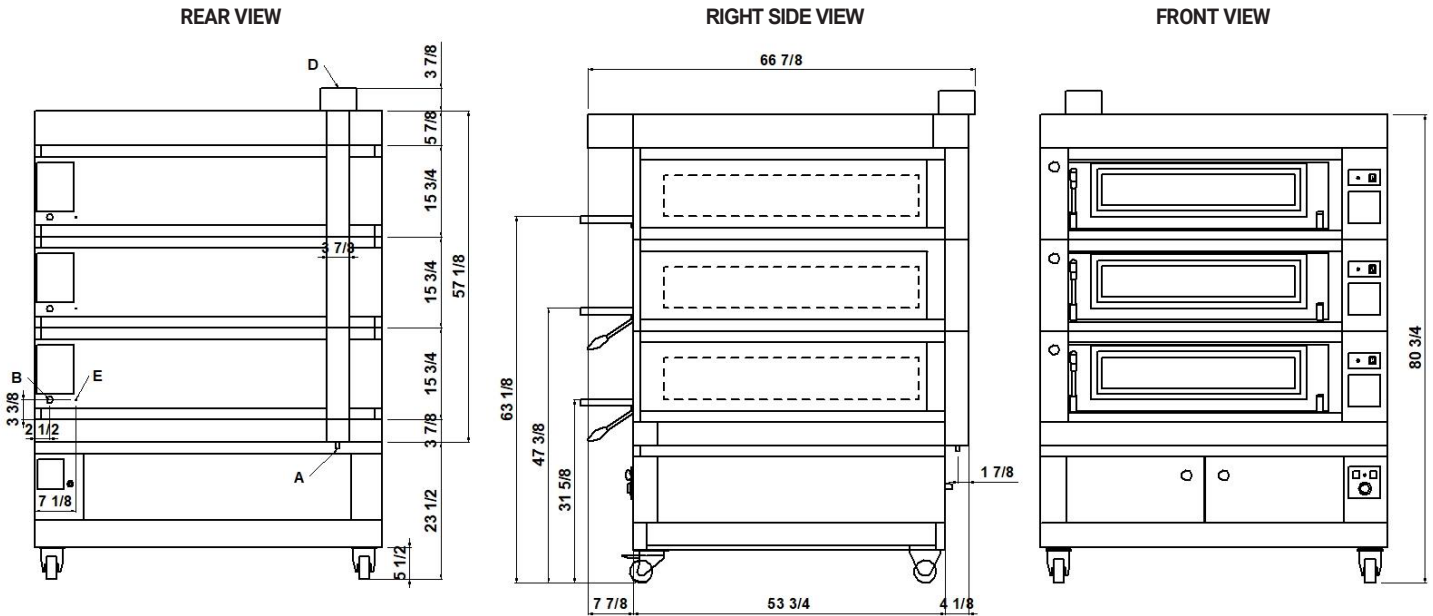

NOTE: The dimensions indicated in the views are in inches.

A	B	D	E
Ø 1/2"		Ø 5 7/8"	M6
condensate exhaust	fairleads	steam exhaust	equipotential screws

DIMENSIONS

External height	57 1/8" (1450mm)
External depth	54" (1365mm)
External width	60" (1520mm)
Weight	1892lb (858kg)

TOTAL BAKING CAPACITY

Tray 26"x18" (600x400)mm	12
Pizza diameter 12"	36
Pizza diameter 18"	15

SHIPPING INFORMATION

Packed in wooden crate

Height	71" (1800mm)
Depth	76" (1930mm)
Width	68" (1720mm)
Weight	2046lb (928kg)

When combined with leavening compartment or stand:

Max height	109" (2750mm)
Max weight	2399lb (1088kg)

FEEDING AND POWER

Standard feeding	V208 3ph
Feeding on request	V240 1ph
Frequency	60Hz
Max power	13,7kW/DECK
*Average power cons	6,9kWh

No cord set supplied

Power supply (optional proofer)
A.C. V(208/240) 1ph 60 Hz

Max power	1,8kW
*Average power cons	0,9kWh



Amalfi D
TECHNICAL DATA

FEEDING AND POWER (EACH DECK NEEDS TO BE CONNECTED INDEPENDENTLY AND THE LOAD SHOWN BELOW ARE PER DECK)	A.C. V208 3ph 60Hz	Standard feeding	Max power	kW	13,7
			*Medium cons/hour	kWh	6,9
			Ampère Max	A/DECK	33
			Connecting cable	AWG/DECK	7
	A.C. V240 1ph 60Hz	Feeding on request	Max power	kW	13,7
			*Medium cons/hour	kWh	6,9
			Ampère Max	A	38,1
			Connecting cable	AWG/DECK	7
	Upon Request A.C. V208 3ph 60Hz boosted heating elements	Standard feeding	Max power	kW	16,0
			*Medium cons/hour	kWh	8,0
			Ampère Max	A/DECK	38,5
			Connecting cable	AWG/DECK	7
	Upon Request A.C. V240 1ph 60Hz boosted heating elements	Feeding on request	Max power	kW	16,0
			*Medium cons/hour	kWh	8,0
			Ampère Max	A/DECK	44,5
			Connecting cable	AWG/DECK	7
A.C. V(208/240) 1ph 60Hz	Proofer	Max power	kW	1,8	
		*Medium cons/hour	kWh	0,9	
		Ampère Max	A/DECK	7,5	
		Connecting cable	AWG/DECK	14	

