

Kombi

Orange

User Manual



Fleet (Line Markers) Limited Fleet House, Spring Lane, Malvern, Worcestershire, WR14 1AT

Tel: + 44 (0) 1684 573535 Fax: + 44 (0) 1684 892784

www.flmuk.com sales@flmuk.com

INTRODUCTION

Thank you for choosing the Kombi Orange Line Marker from Fleet (Line Markers) Limited. Founded in the 1950's, Fleet are regarded as the world's leading expert in the field of line marking.

Of course it's not just the machines that Fleet are famous for, our range of line marking paints are used around the world, wherever the pitch, whatever the occasion.

For more details on any of the products in Fleet's range please visit www.flmuk.com

CONTENTS

	Assembly
	Operation
	Maintenance
	Storage
	Troubleshooting
	Parts list
	Warranty

ASSEMBLING YOUR KOMBI ORANGE LINE MARKER

PREPARING FOR USE

1. Carefully remove the machine and accessories from packaging.
2. Insert handlebar section; adjust to suit user's height and tighten using thumb screws.
3. Bar ends can be adjusted to suit hand position using the supplied 5mm allen key.
4. Connect control panel using the coiled power cable. (Fig 1)

(Fig 1)

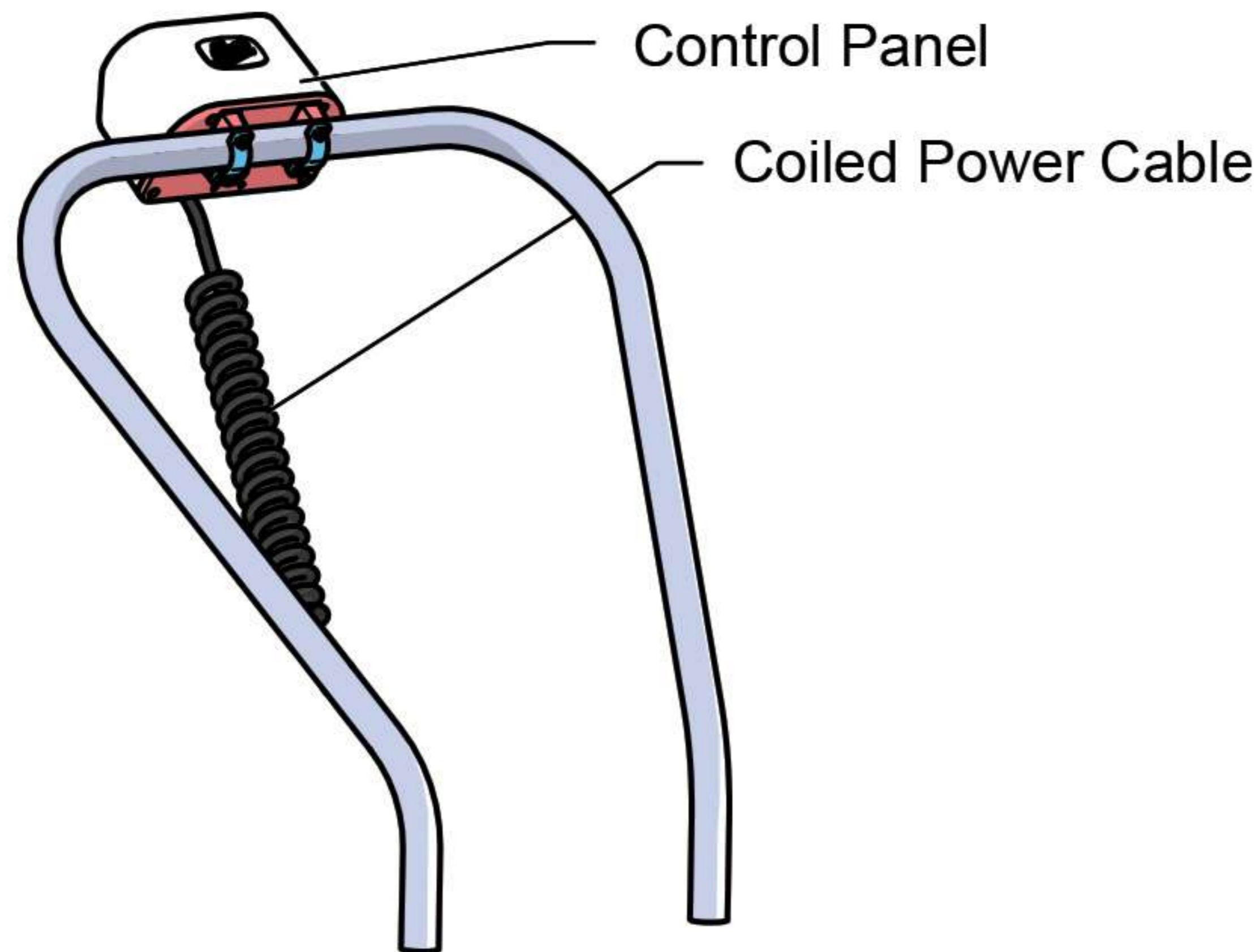

NOTE: failure to align keyways and forcing plug into socket **WILL** cause damage and **VOID WARRANTY**

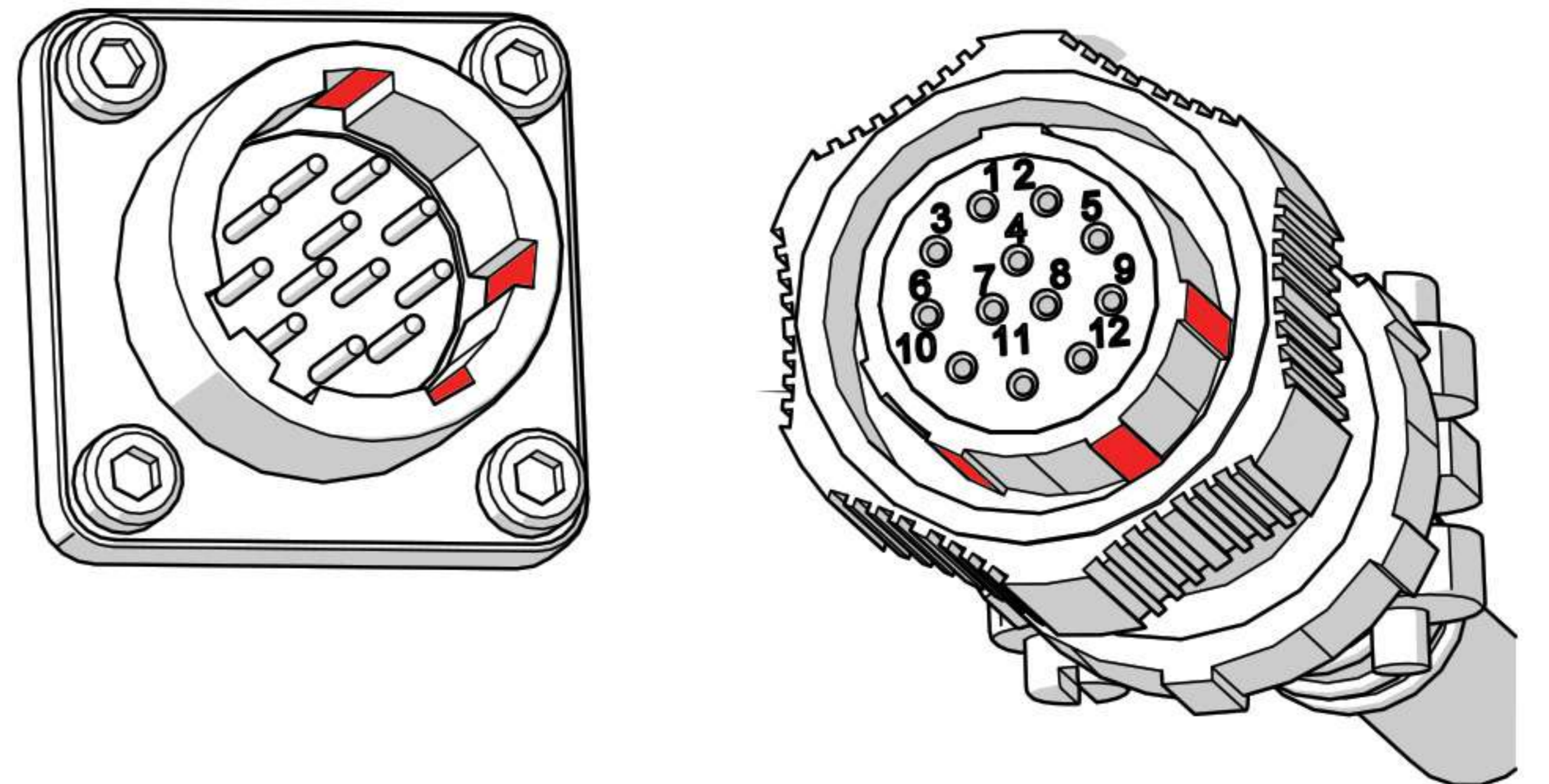

5. Lift bonnet, take out packing wedge and remove docking battery.
6. Position charging station near a 230/240V AC power supply, dock the battery and switch on. (Fig 2)

CAUTION. Only use the supplied charger. Use of other equipment may cause fire or damage the battery. Maintain battery charge at all times, charge once a month if stored for long periods without use.

(Fig 2)

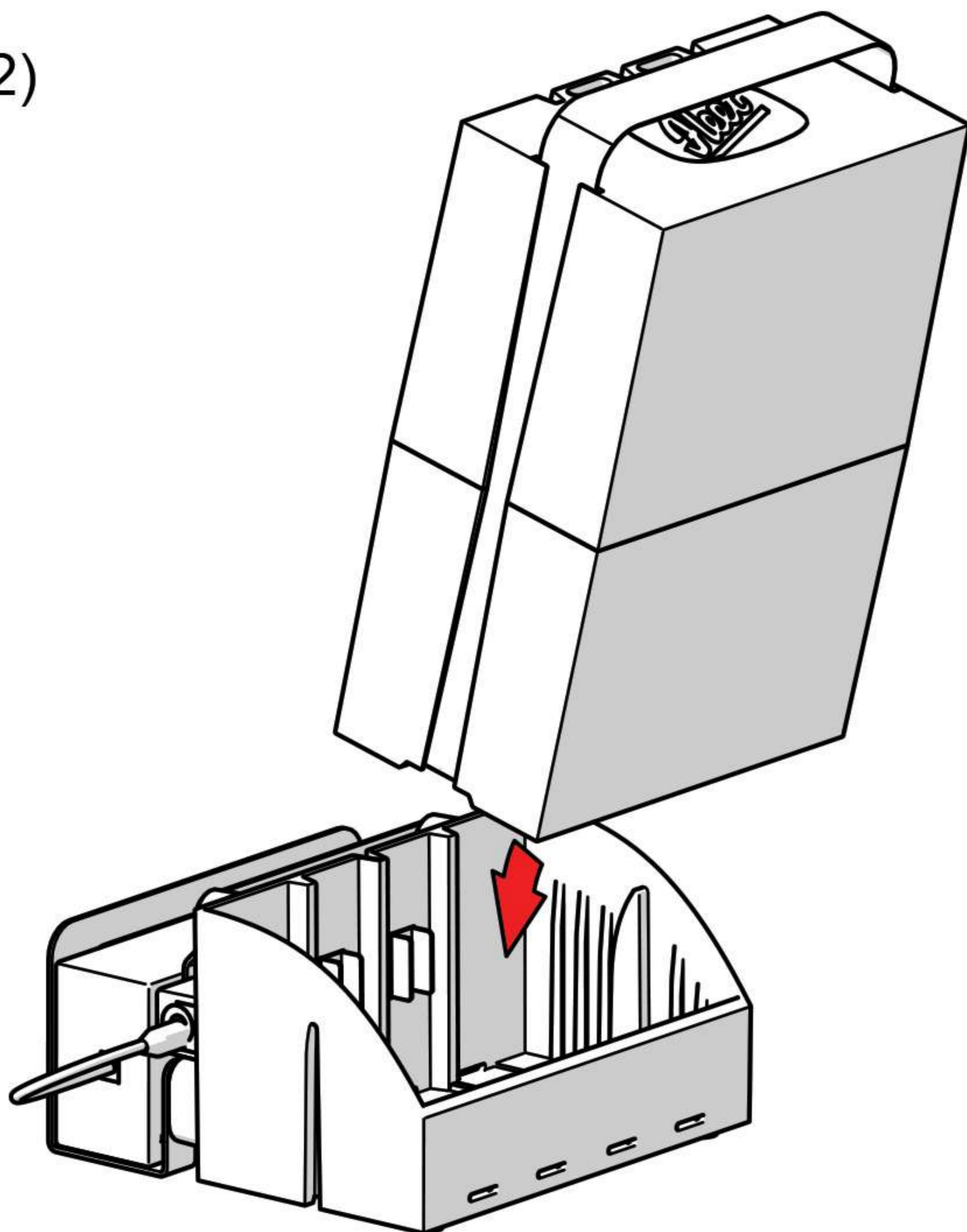

(Fig 3)

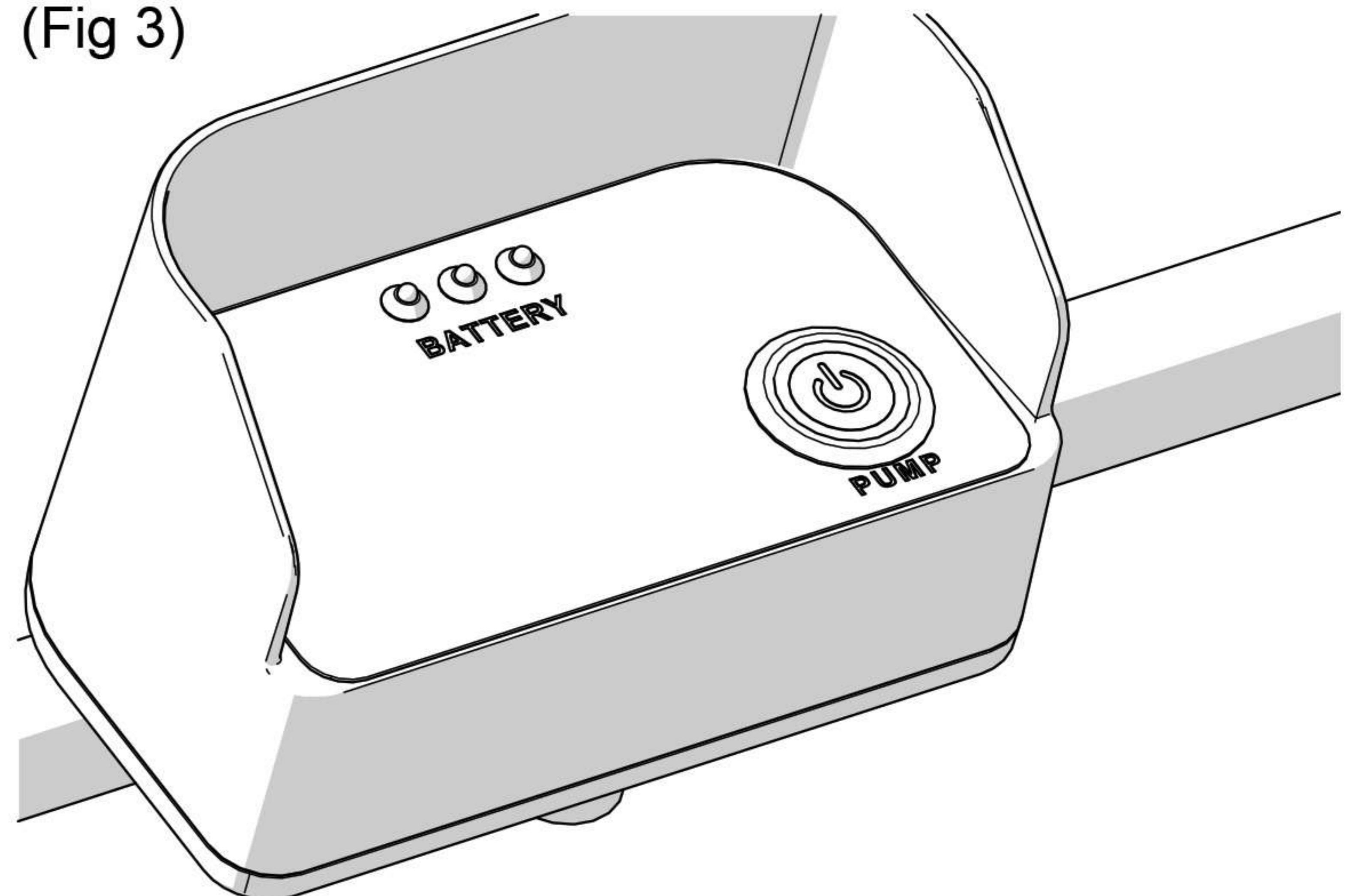

NOTE: When green light is no longer showing, approx 15 minutes of charge will remain.

7. When charging, the LED on the charger illuminates red. When the battery is fully charged, the LED illuminates green. Once green, remain charging for a further 60 minutes, a full charge can take 4-6 hours on average.
8. Once charged, dock battery within the machine. Battery status can be monitored during use by the LED display on the control panel. (Fig 3).

KNIB AND NOZZLE ASSEMBLY

The knib and nozzle assembly is located inside the paint tank of the machine and requires some assembly before use.

Refer to the diagram below and follow these steps.

1. Remove packaging from tank.
2. Place arms (A) & (B) over the pivot bar (C).
3. Fit a washer (D) on each end of the pivot bar shaft, secure using R Clip (E).
4. Insert nozzle support arm (F) into support pillar (G) and secure with thumb screw (H).

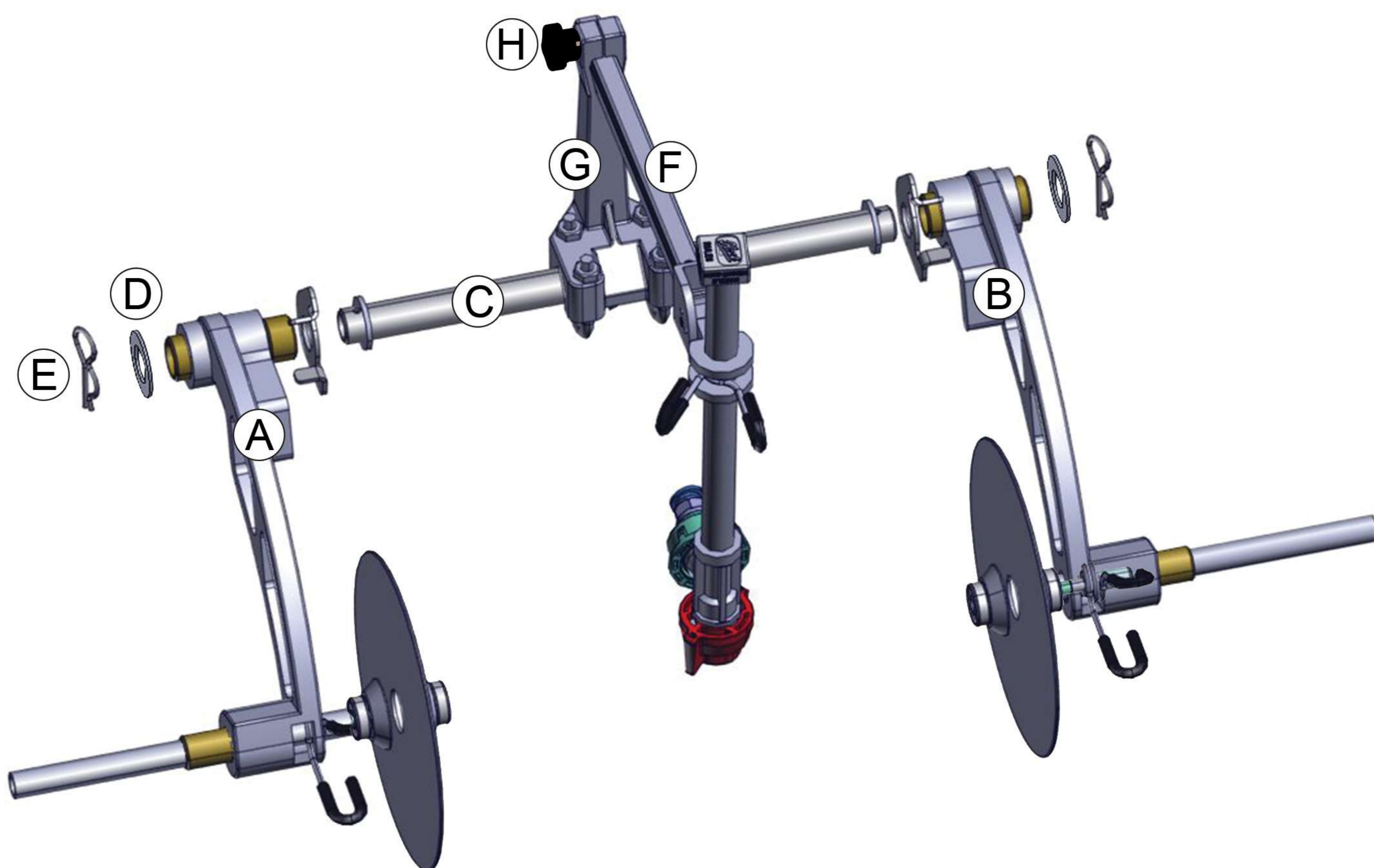

The knib and nozzle assembly can be fitted to the central post at the front of the machine or to either side of the front axle.

Front mounted knib and nozzle assembly

1. Fit the knib and nozzle assembly onto the tapered stem at the front of the machine.
2. Compress knib retainer clip and position the arm on the flat of the support pillar.
3. Hinge the nozzle assembly to the vertical position.
4. Ensure that the nozzle is centred between the line forming disks, adjust if necessary using the thumb screw.
5. Connect blue coiled hose to front bulkhead connector.

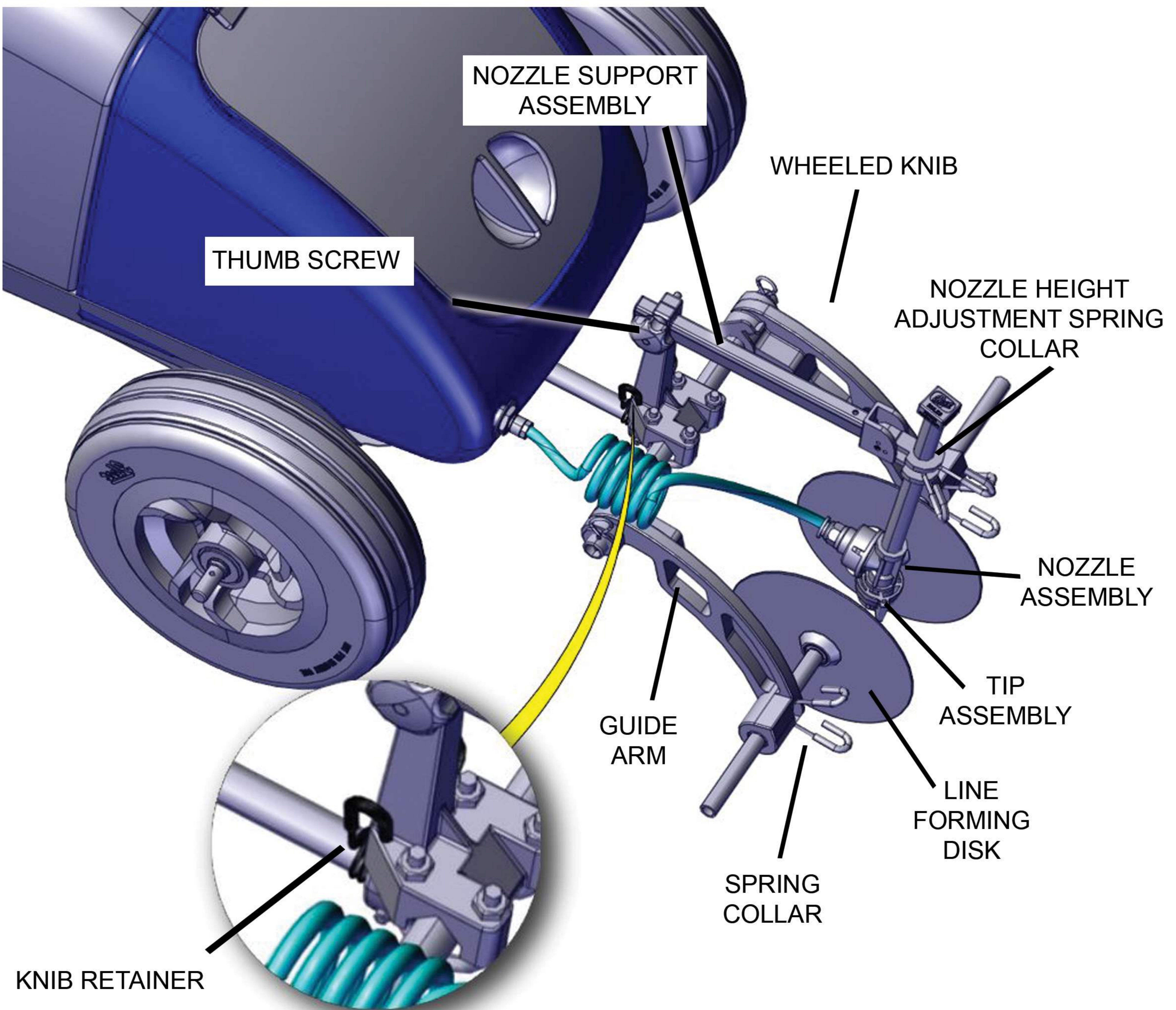

(Fig 4) Knib and nozzle assembly mounted on the front of the machine.

Side mounting your knib

1. Remove the R clip from the required side of the knib. (Fig 5)
2. Fit the pivot bar of the knib over the axle and align the holes. Refit the R clip to secure the knib to the axle.
3. Hinge the nozzle post to the vertical position and ensure that the nozzle is centred between the line forming disks. Adjust if necessary.

Note: Further adjustment of the nozzle position can be achieved by adjusting the U bolts.

4. Arrange the blue coiled hose away from the wheel and connect to side bulkhead fitting (Fig 6)

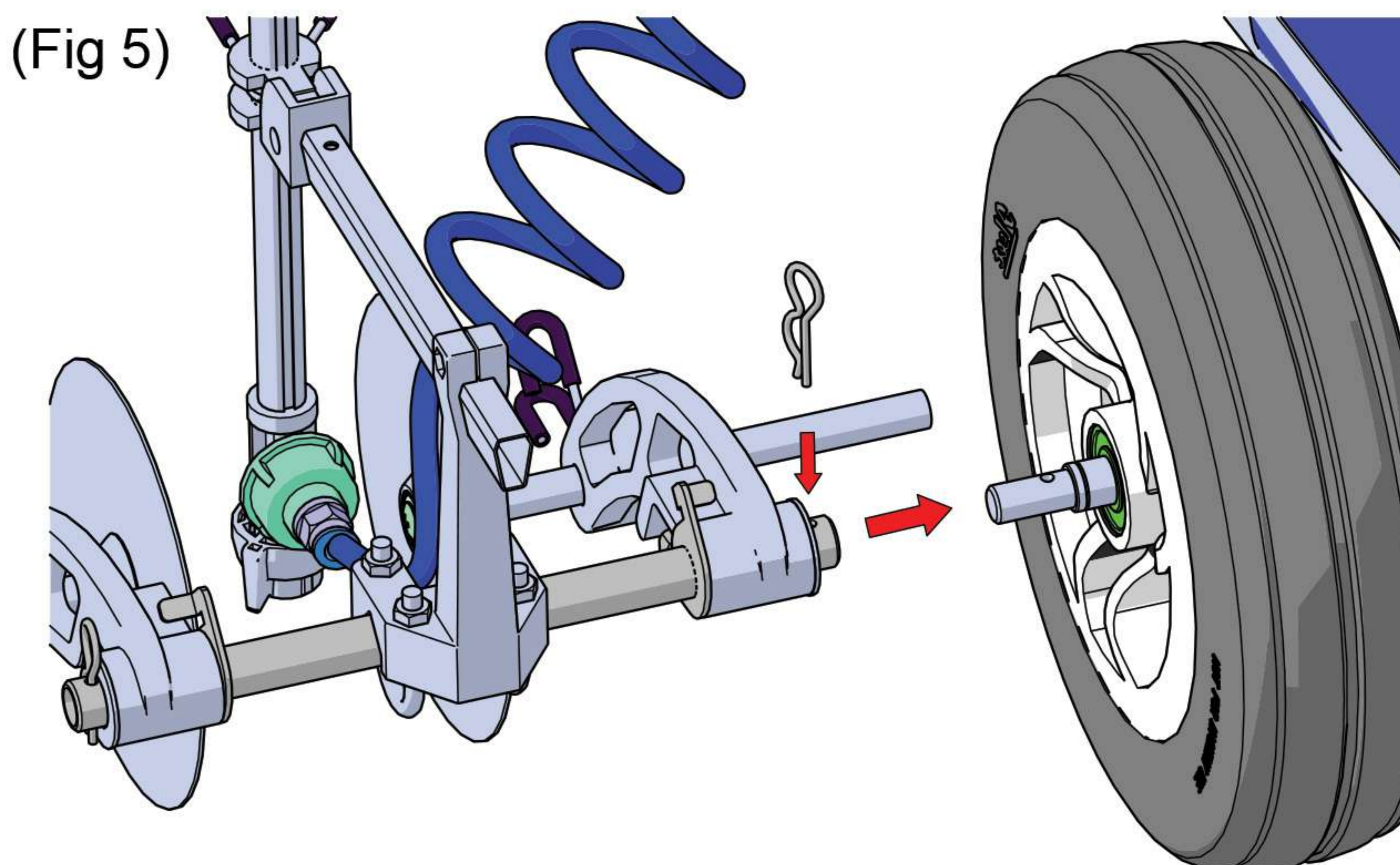

(Fig 6)

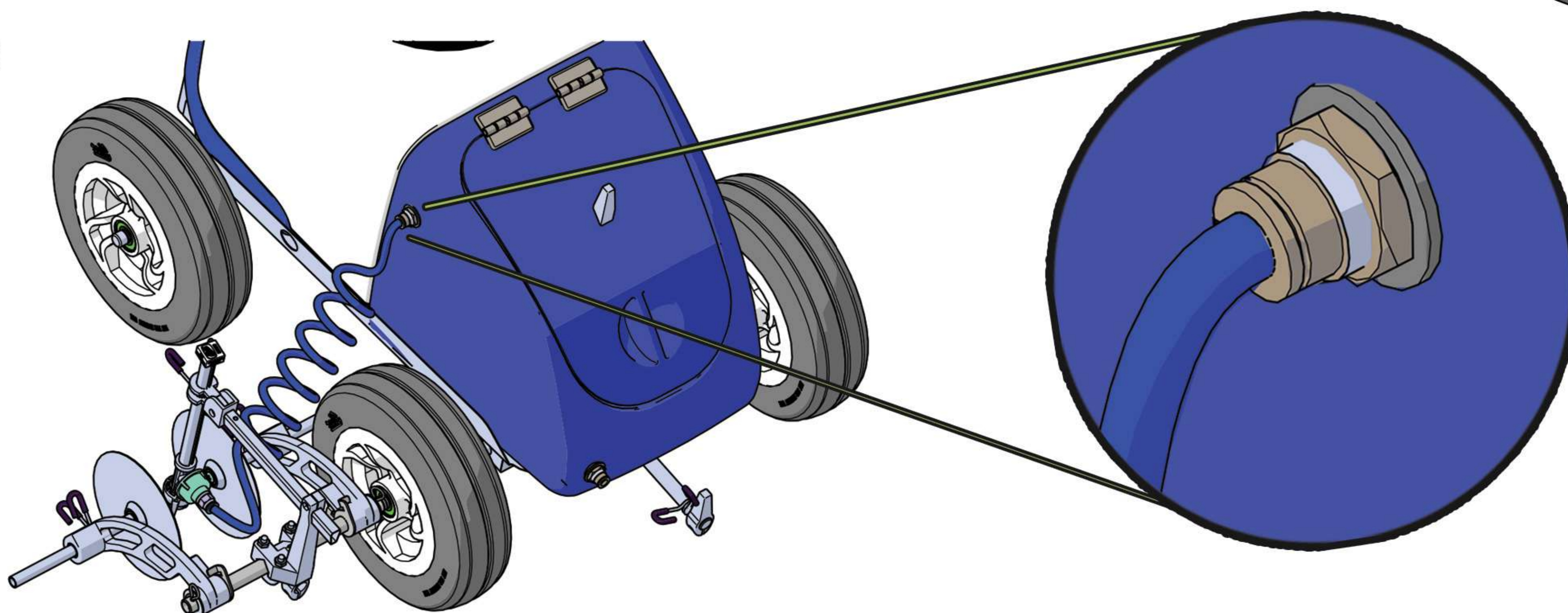

NOTE: Knib can be fitted in either trailing (Fig 7) or forward facing position.(Fig 8)

(Fig 7)

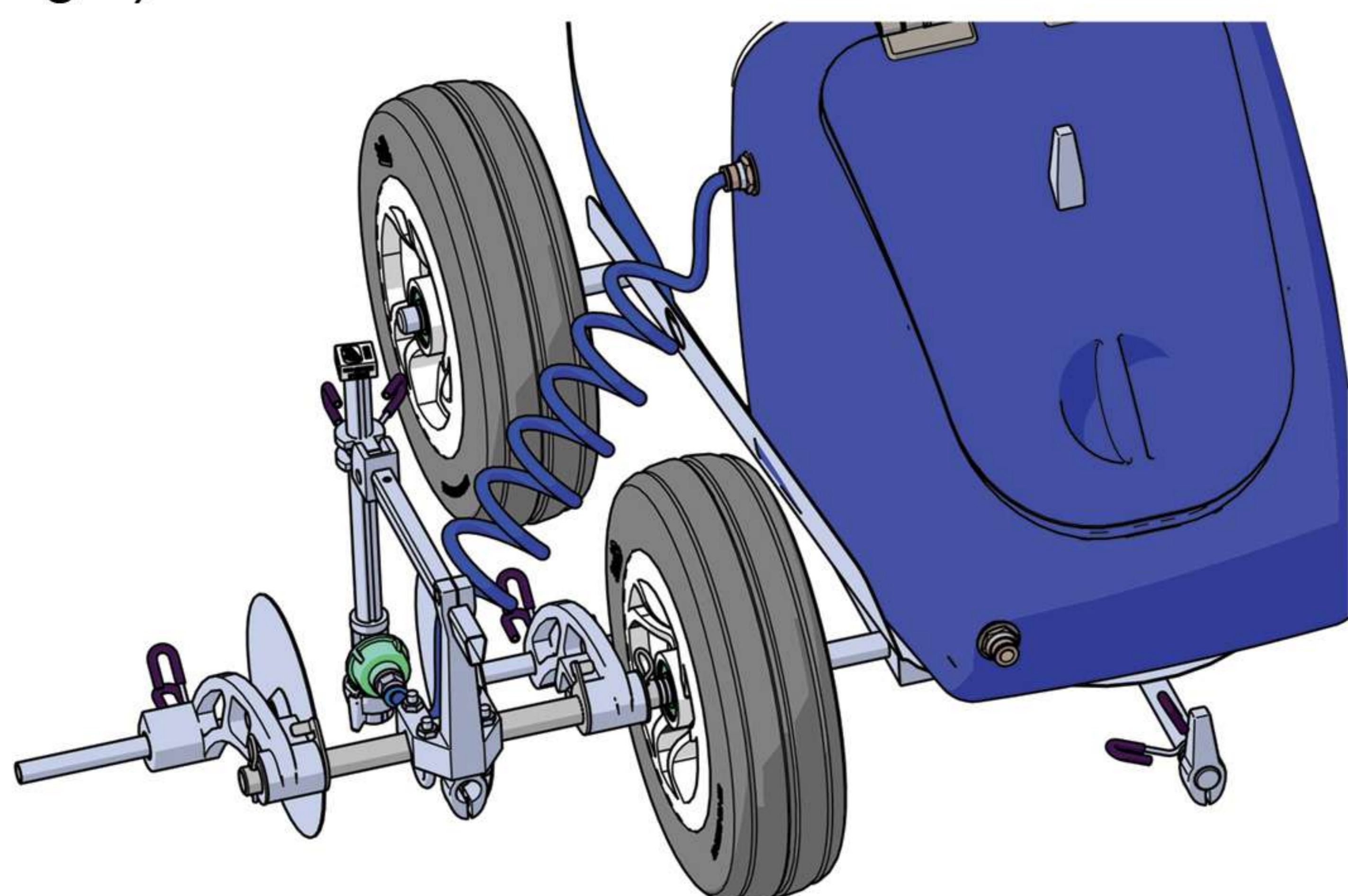

(Fig 8)

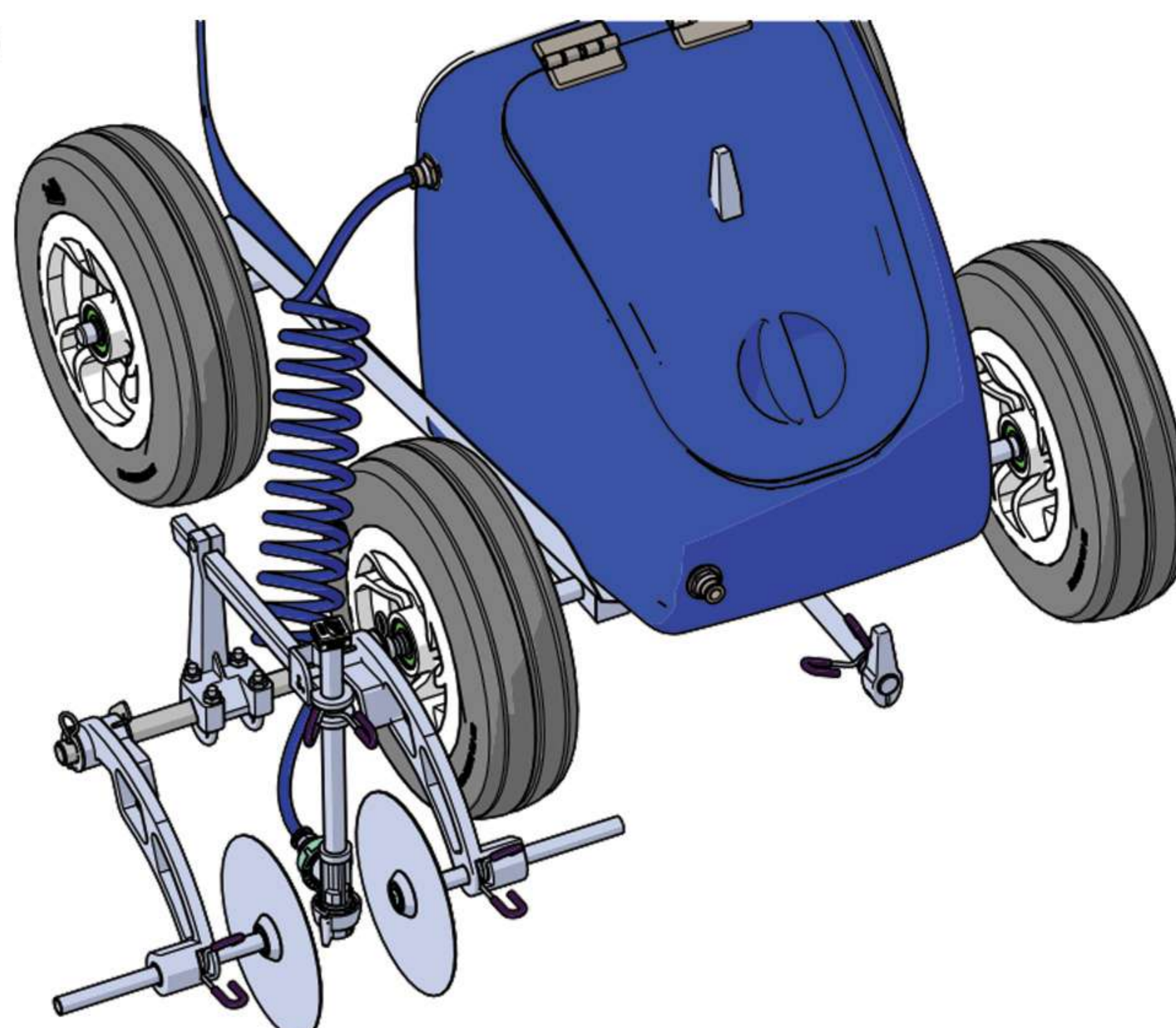

The following steps need to be taken in order to modify the machine to use the side connector.

1. Take the new length of clear hose from the tool bag, insert hose in to the rear of the side bulkhead connector. (Fig 9a)
2. Remove paint hose from the rear of the front bulkhead connector and Y shaped connector, insert end of new pipe in to Y shaped connector. (Fig 9b)
3. Completed pipework you are now ready to mark. (Fig 9c)

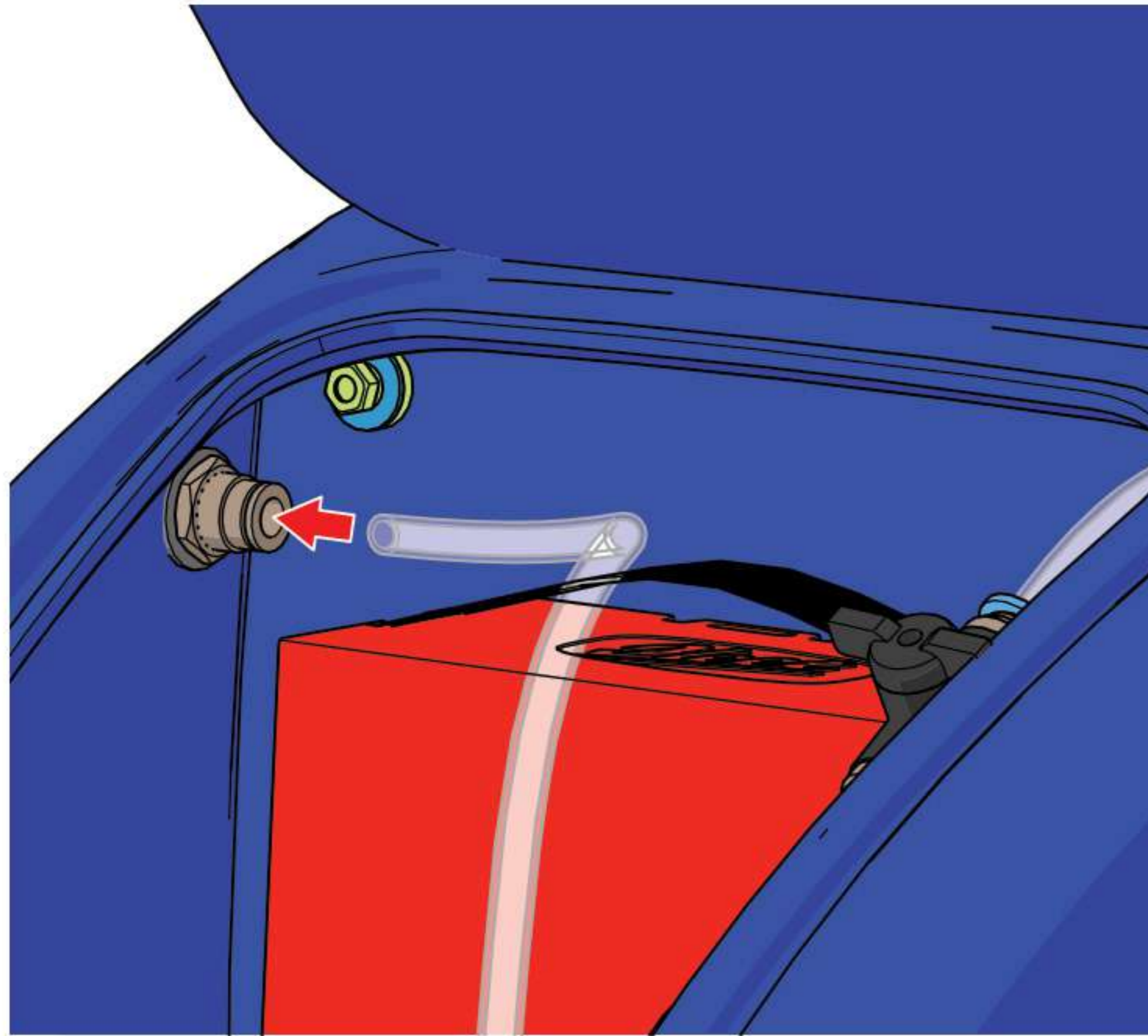

(Fig 9a)

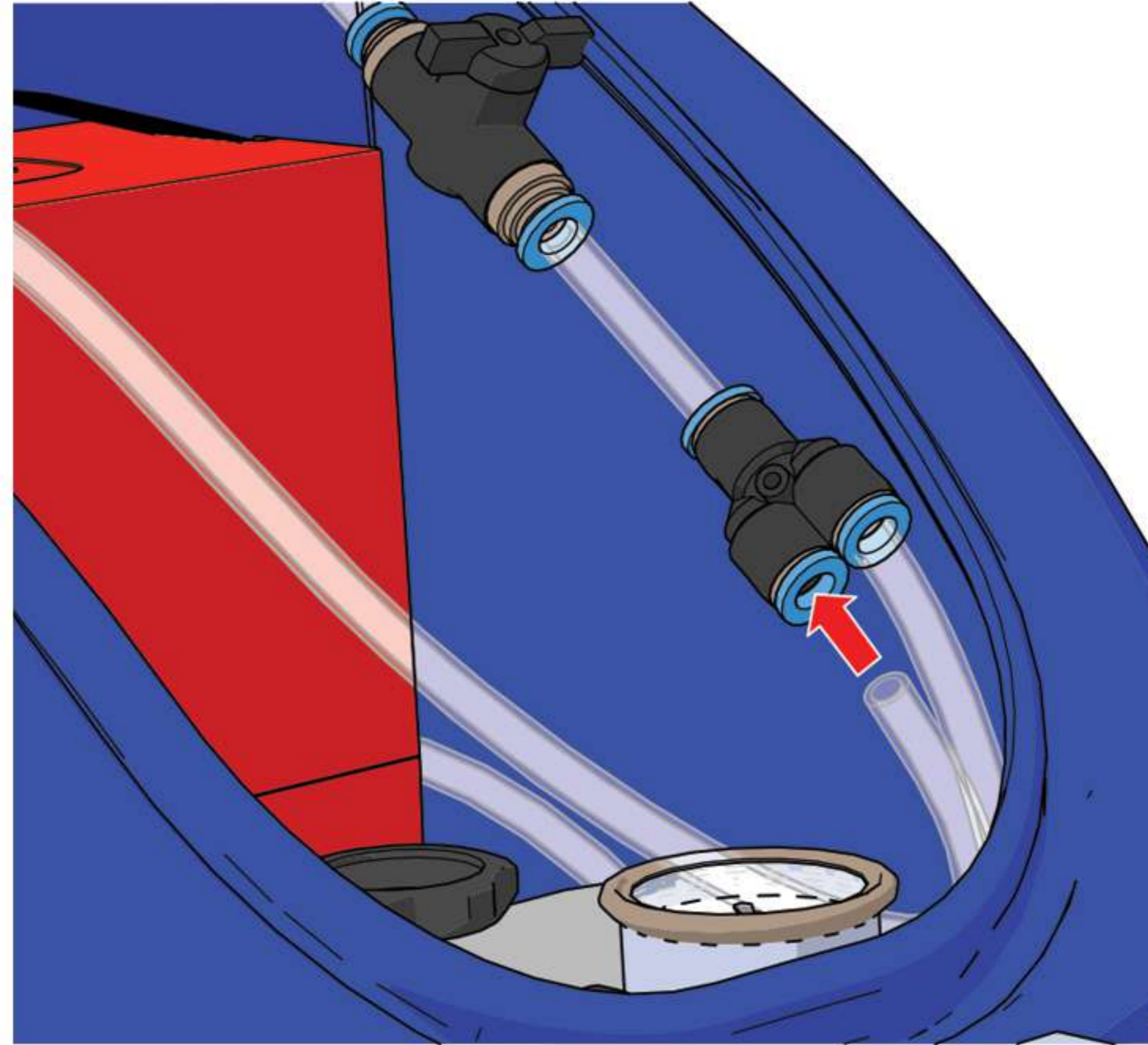

(Fig 9b)

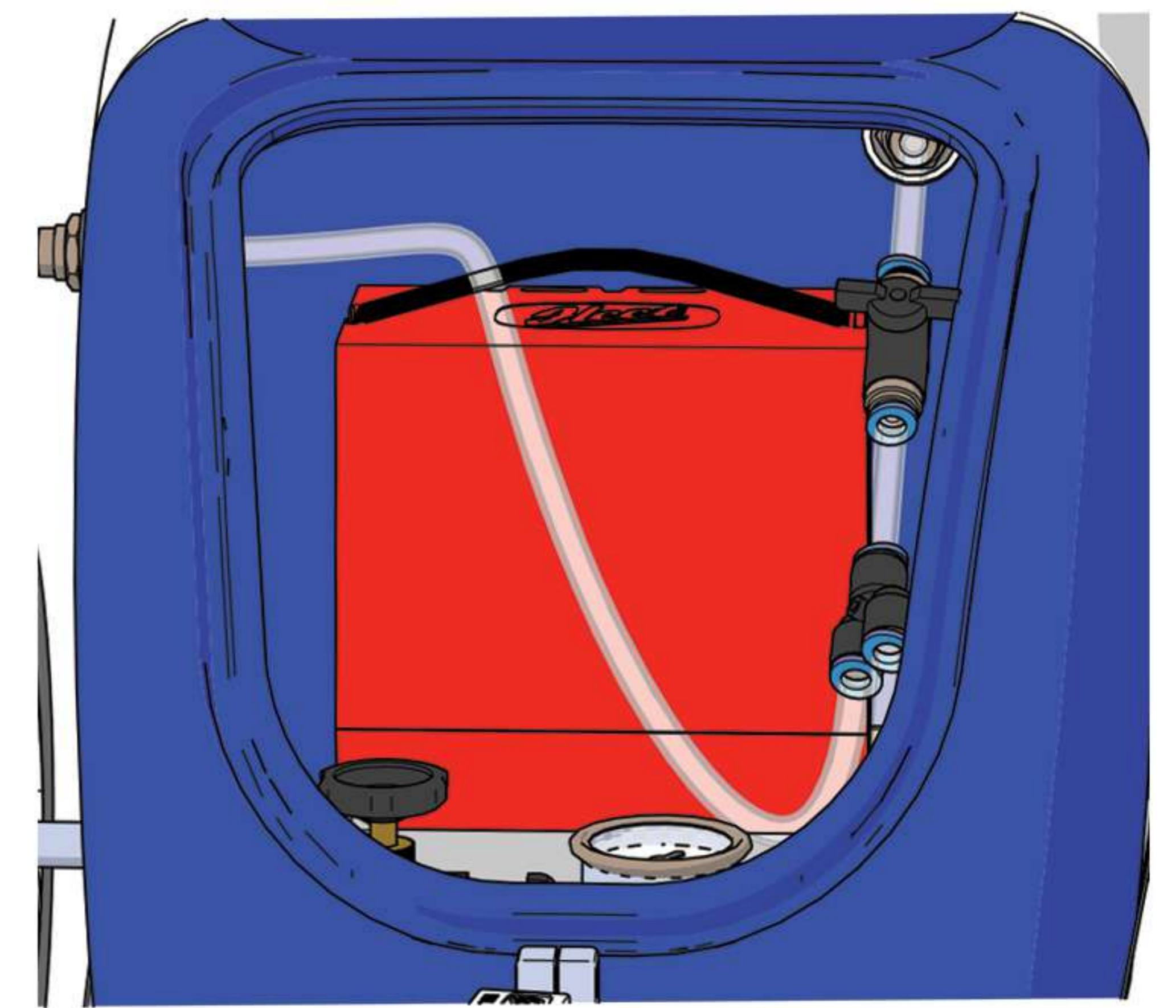

(Fig 9c)

Should you want to revert to front marking the previous steps will need to be reversed.

OPERATING YOUR KOMBI ORANGE LINE MARKER

Filling the water tank

1. Remove filler cap from the rear of the machine.
2. Fill the water tank with clean water, ensure no debris enters the tank and replace cap. (Fig 10)

(Fig 10)

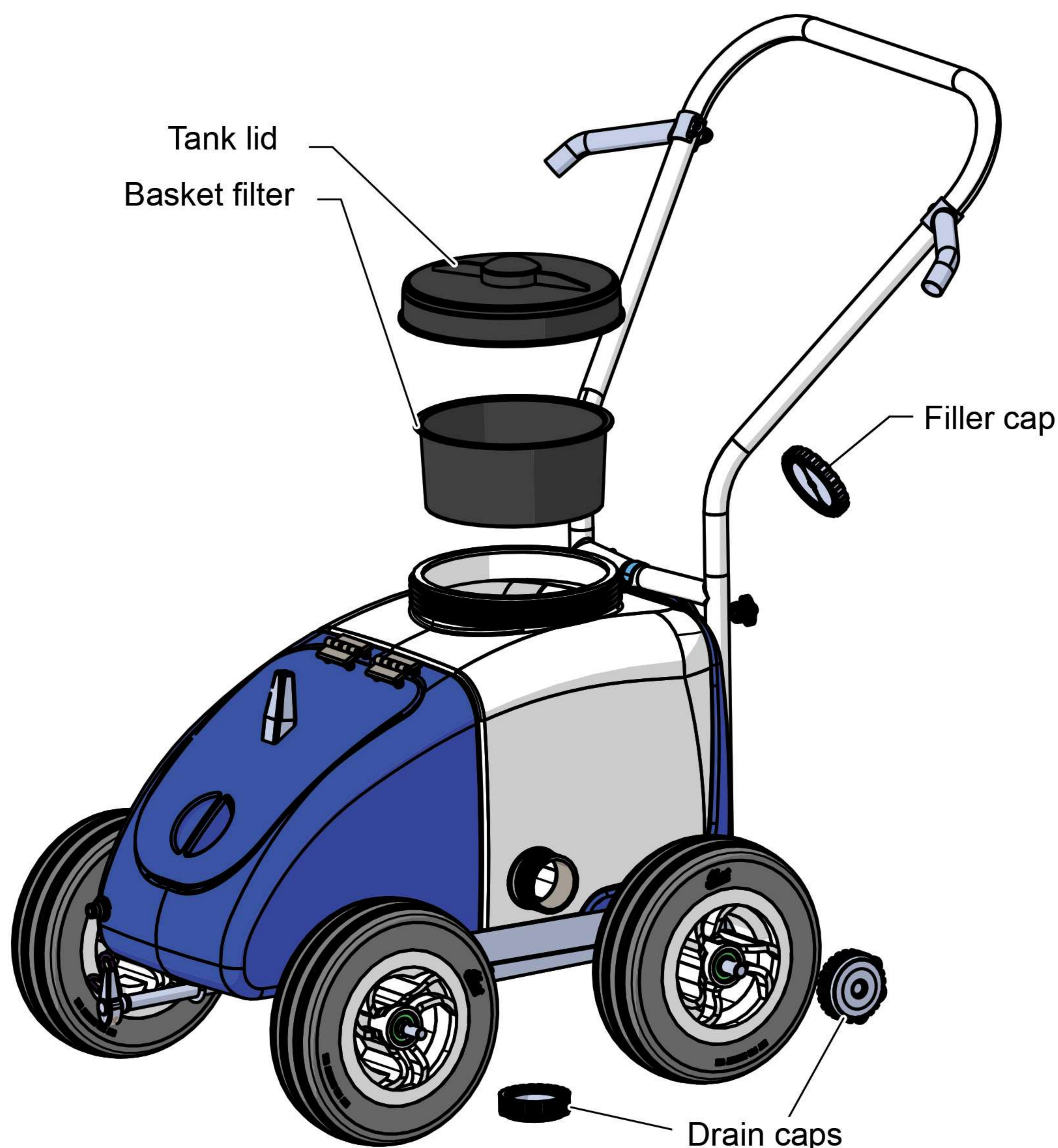

Filling the paint tank

Place the basket filter into the neck of the paint tank. **ALWAYS** use basket filter to eliminate debris from entering the tank.

Concentrated paints

- A. Fill the paint tank with water to correct dilution rate, tank markings are provided as a guide.
- B. Fill the paint tank with the selected Fleet paint and refit the lid.

Note: always pour water in first followed by Fleet paint.

Ready to use paints

- A. Pour Fleet ready to use paint into paint tank.

Flow return tap

The Kombi Orange line marker is fitted with a flow return tap, this can be used for mixing concentrates and bleeding air from the system.

To operate the flow return system, proceed as follows:

1. Ensure the Paint/Water changeover valve is in the 'Paint' position (lever pointing forward) (Fig 11)
2. Turn the pressure valve fully clockwise (maximum pressure) (Fig12)
3. Turn the flow return tap through 90° (In line with the hose. See Fig 12)
4. Switch the machine on by pressing the ON/OFF button located on the control panel, paint will now circulate around the system and back into the paint tank.
5. Turn the pressure valve 1/4 turn anti-clockwise, this will bleed any air left in the system. Leave machine running for a few minutes before switching off.

(Fig 11)

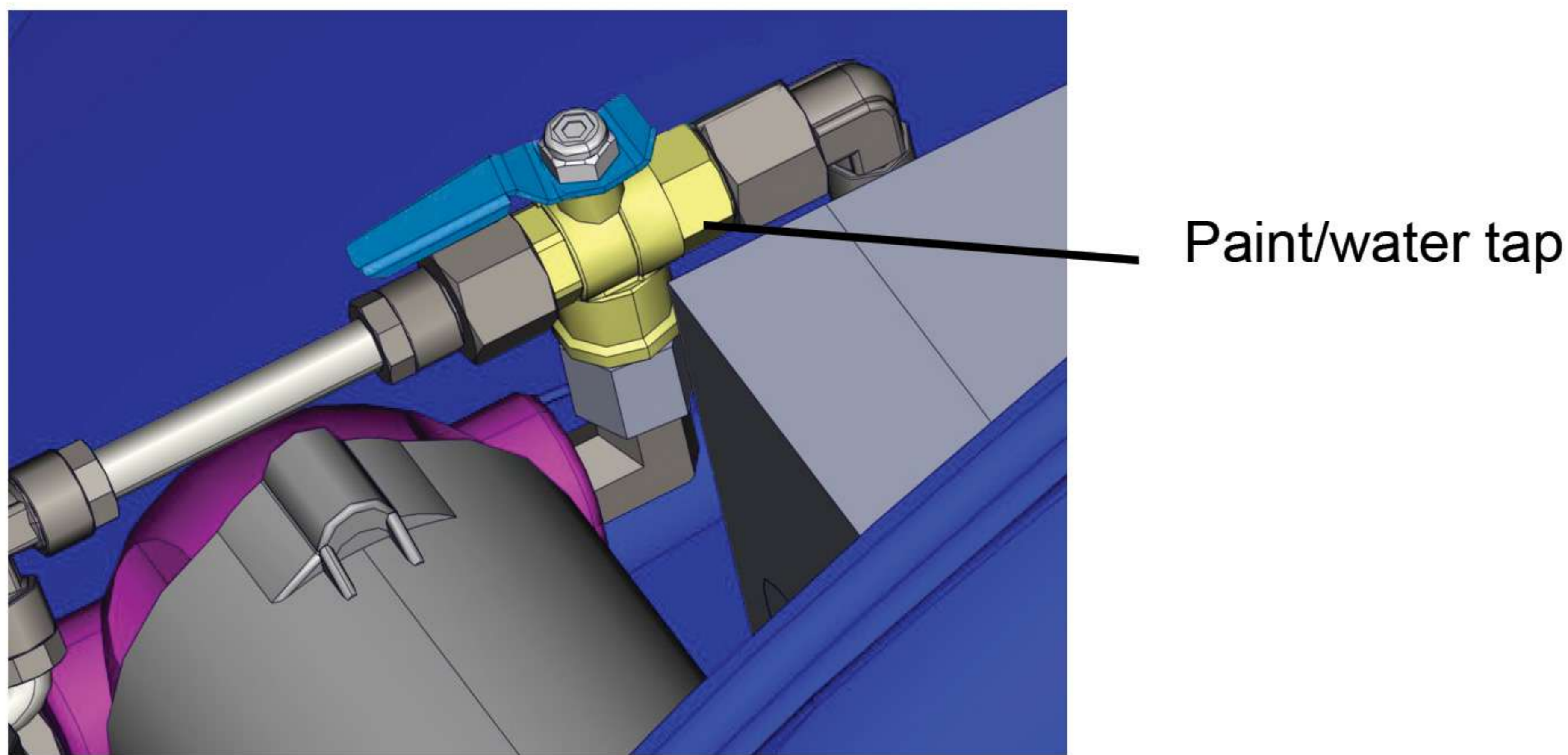

(Fig 12)

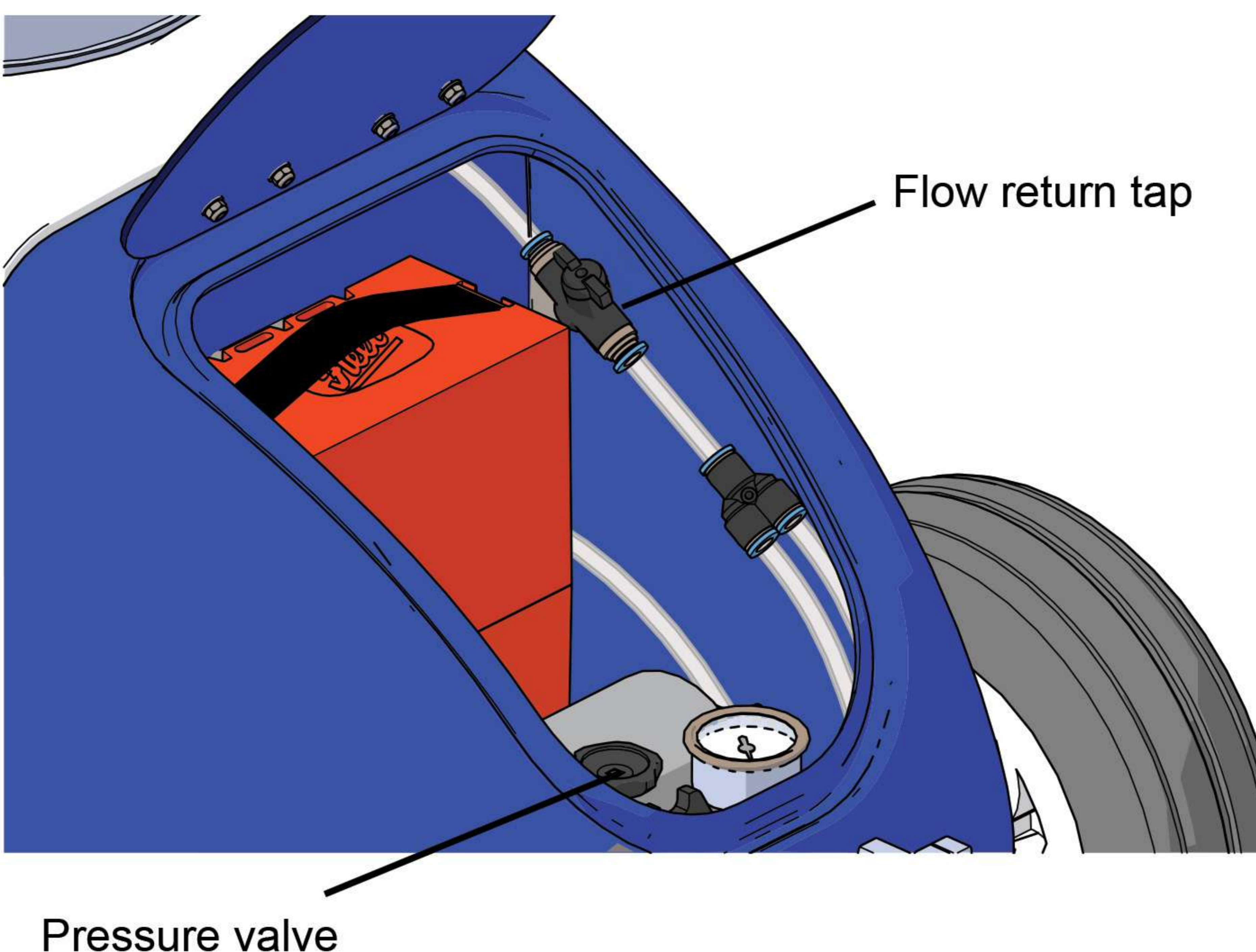

Note: The flow return system cannot be used when using the paint bag system.

Setting the line width

The line width is determined by the width between the guide disks and the nozzle height. Both must be adjusted correctly to obtain a good line with the optimum paint usage. A ruler is located in the nozzle post for measuring the line width and the nozzle height.

1. With the line forming disks resting on the ground, compress the spring collars and slide the line forming disks in or out to achieve the desired line width.

IMPORTANT: Both the line forming disks must be adjusted so that the nozzle is central between them.

(Fig 13)

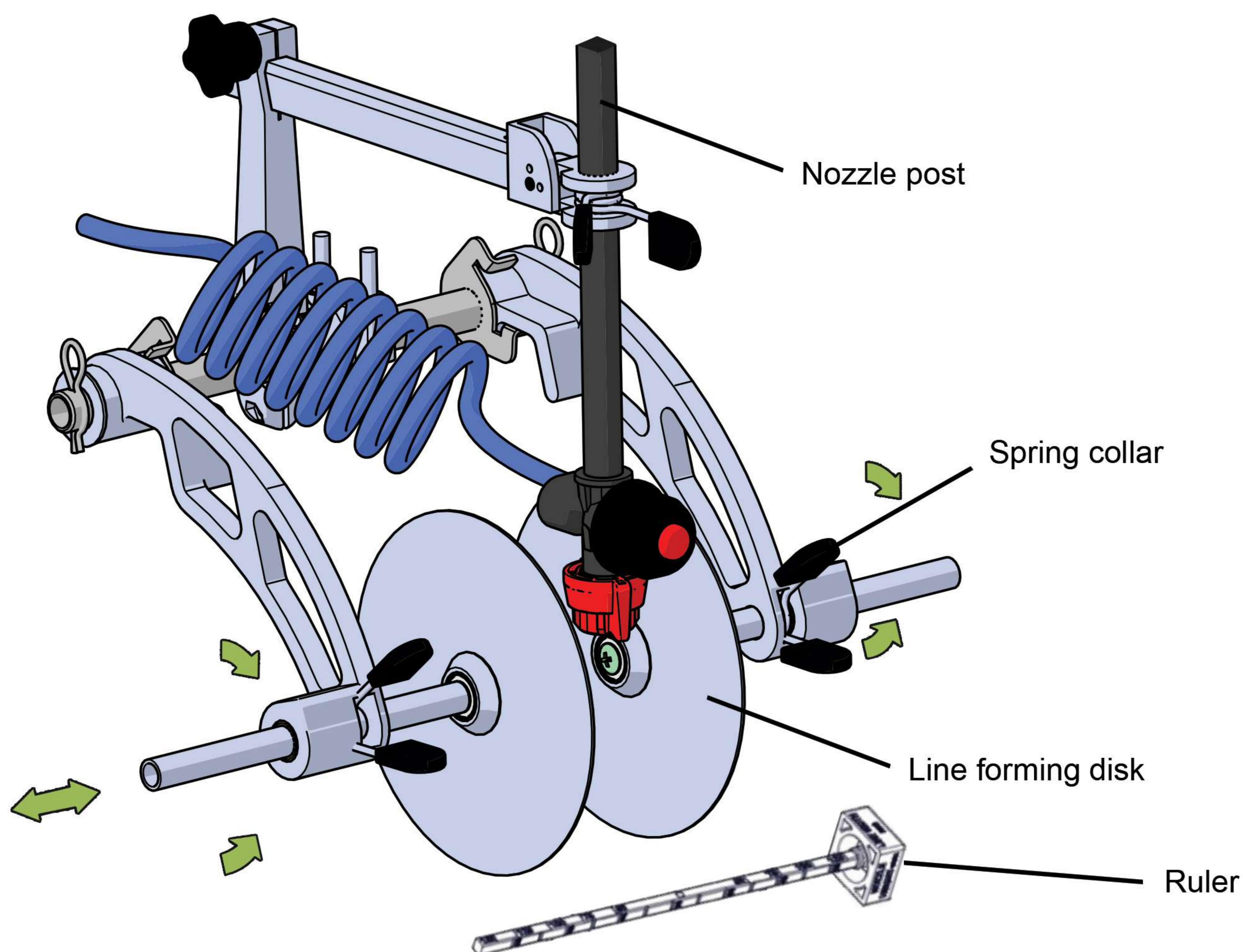

Setting the nozzle height

1. Hinge the nozzle post to the vertical position. Adjust the nozzle height by the squeezing the spring collar and sliding the nozzle post up or down for the desired line width. A ruler is provided in the nozzle post.
2. A reference guide is located underneath the bonnet and gives approximate nozzle height for a range of line widths. **NOTE:** This is only intended as a guide. The operator must observe the spray pattern and adjust the nozzle height to form a good line for the local conditions e.g. length of grass.

3. On an area of ground away from the pitch, briefly switch on the pump. Observe the pressure gauge (refer to page 11). Adjust the pressure with use of the valve. Observe the spray pattern. Check that the spray fan just reaches the line forming disks at the top of the grass height. For hard surfaces the spray fan should just reach the line forming disk at the ground surface. If necessary adjust the nozzle height. Turn off the pump.

(Fig 14)

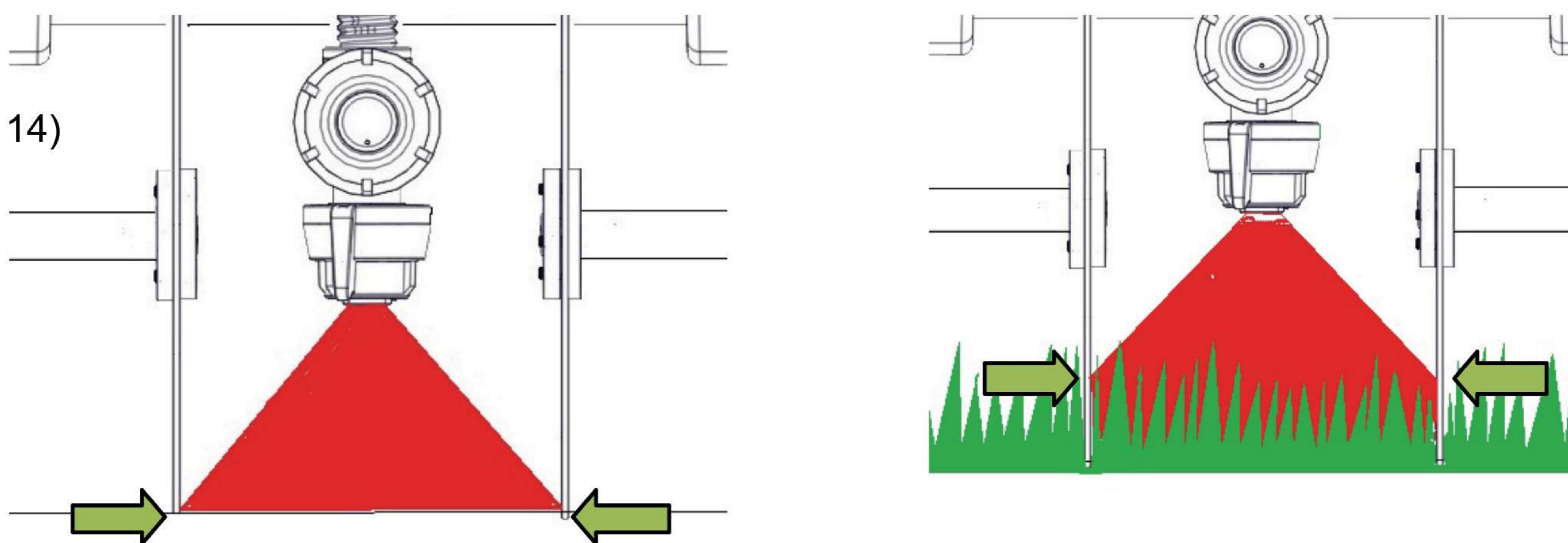

4. Close the bonnet. Ensure the blue coiled hose is arranged with no kinks and is not fouling on the guide disks. The Kombi Orange line marker is now ready for line marking.

LINE MARKING WITH YOUR KOMBI ORANGE LINE MARKER

WARNING - HIGH PRESSURE THE KOMBI ORANGE LINE MARKER HAS A WORKING PRESSURE OF UP TO 80 psi. DO NOT OPEN ANY PIPE JOINTS WHILE THE PUMP IS OPERATING.

Setting the pressure

1. The pressure of the spray can be adjusted for different applications by turning the pressure adjustment valve clockwise / anti-clockwise. The pressure gauge will indicate machine pressure.

NOTE: The lower the pressure, the greater the paint economy. Pressure set below 18 psi will not overcome the DCV (drip control valve) and therefore will not spray.

(Fig 15)

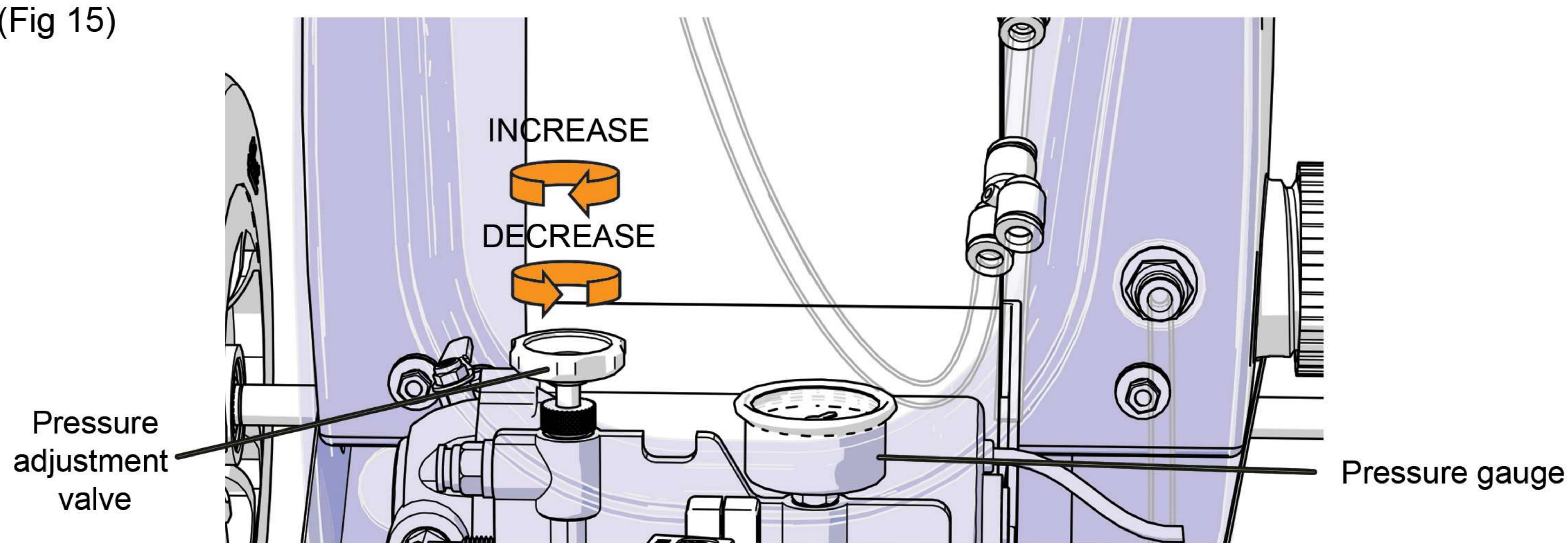

Marking a line

1. Ensure there is correctly mixed product in the paint tank.
2. Ensure the battery is fully charged.
3. Paint/Water valve is in the 'Paint' position (lever pointing forward)
4. Ensure the flow return tap is in the OFF position (tap lever at 90° to the hose)
5. Switch the pump ON and immediately start walking at a steady and constant speed along the guide line. The guide line could be a previously marked line, string or chalk line.
6. At the end of the line switch the pump OFF and stop walking.
7. Lift the line forming disks from the surface and position the machine at the start of the next line.
8. If there is to be a break in marking always flush the nozzle with water using the Paint/Water change over tap. Briefly flush the nozzle into a container or on waste ground away from the pitch area. Refer to page 12.

Marking circles

An eyelet is located on the chassis (left hand side) to aid marking circles. This can be used with a string or chain line located off a central point allowing the machine to maneuver in a uniform circle. (Fig 16)

(Fig 16)

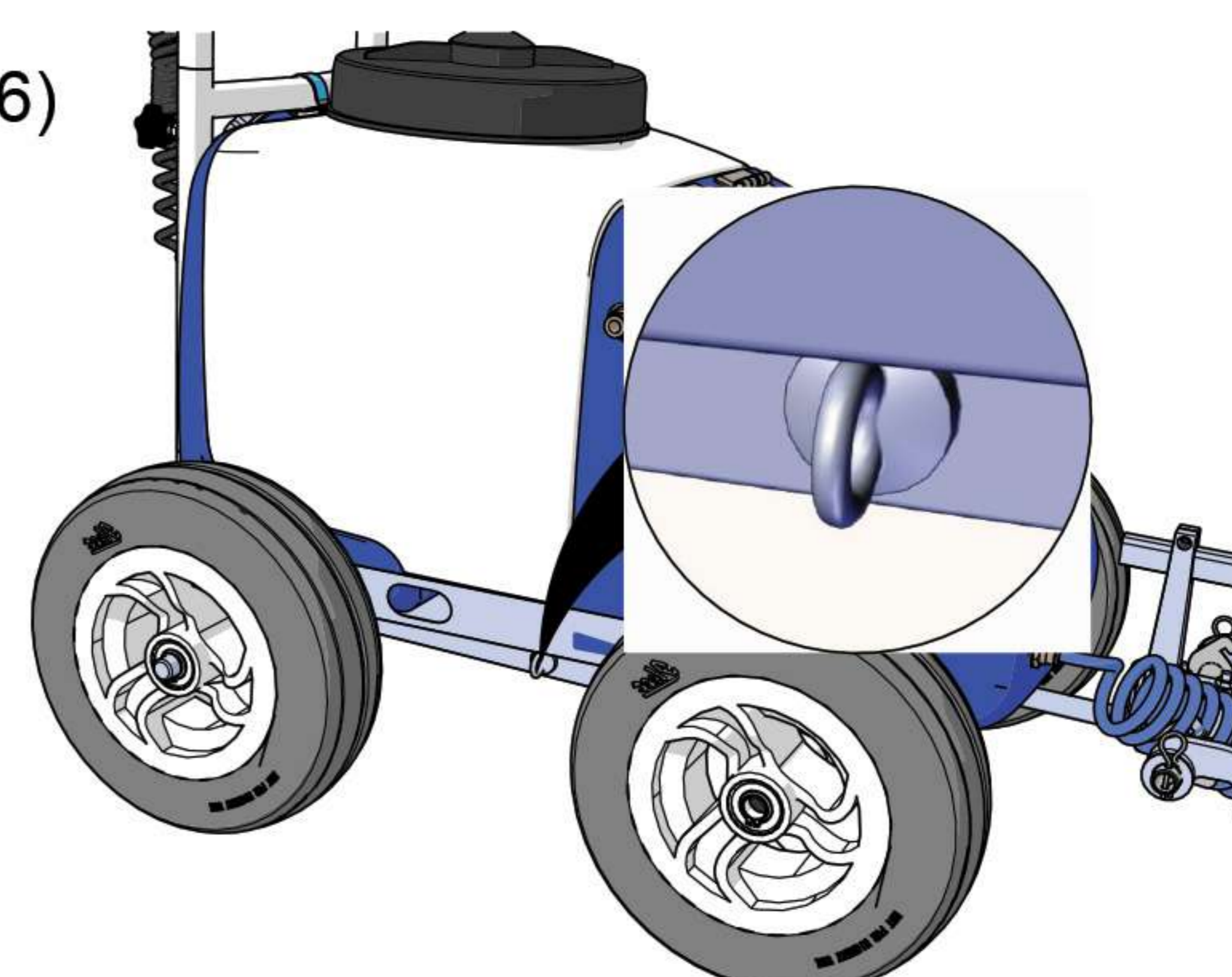

FLUSHING AND CLEANING

IMPORTANT: When cleaning/flushing the Kombi Orange line marker, ensure that water courses are not contaminated with paint. If in doubt, check with the local authority.

Quick flush (daily)

This can be used before breaks in operation or at the end of a line marking day.

1. Ensure that the water tank has sufficient water for the cleaning operation.
2. Position the machine where the contents of the pipework can be flushed and cleaned.
3. With the paint/water tap in the 'water' position (Fig 17), turn on the pump. Allow the water to spray through the nozzle, when clear water is observed turn off pump.

Full system flush (weekly)

It is not recommended to store paint in the machine for longer than 24hrs

1. Ensure that the water tank has sufficient water for the cleaning operation.
 2. Position the machine where it can be flushed and cleaned.
 3. With the paint/water tap in the 'water' position (Fig 17), and the flow return tap inline with the pipe, turn on the pump. Allow water to circulate into paint tank, when running clear, turn off pump.
 4. The contents of the paint tank can be emptied in to a suitable sealed container. Remove drain cap and tilt machine to empty.
 5. Paint tank should be cleaned to remove any excess paint from the bottom and sides.
 6. Replace drain cap and fill with 5 litres of clean water and optional Kombi Klean.
 7. Position the nozzle assembly over a drain or suitable container.
 8. With the paint/water change over tap in the 'paint' position (Fig 17) and pressure adjustment valve fully closed, turn on the pump. Allow the water to spray through the nozzle until paint tank is empty.
- NOTE:** The pressure adjustment valve should be opened by 1/4 turn anti-clockwise during this process to clean manifold.
9. Remove the bayonet cap complete with the nozzle tip and filter. If necessary, rinse to clean.
 10. Refit the bayonet cap complete with the nozzle tip and filter.
 11. Using a damp cloth or Fleet wipes, clean any paint overspray from the following:
 - a. Line forming disks and guide shafts. Build up of paint on the guide shafts will make line width adjustment more difficult.
 - b. Generally clean and remove paint overspray or spills from the machine.

(Fig 17)

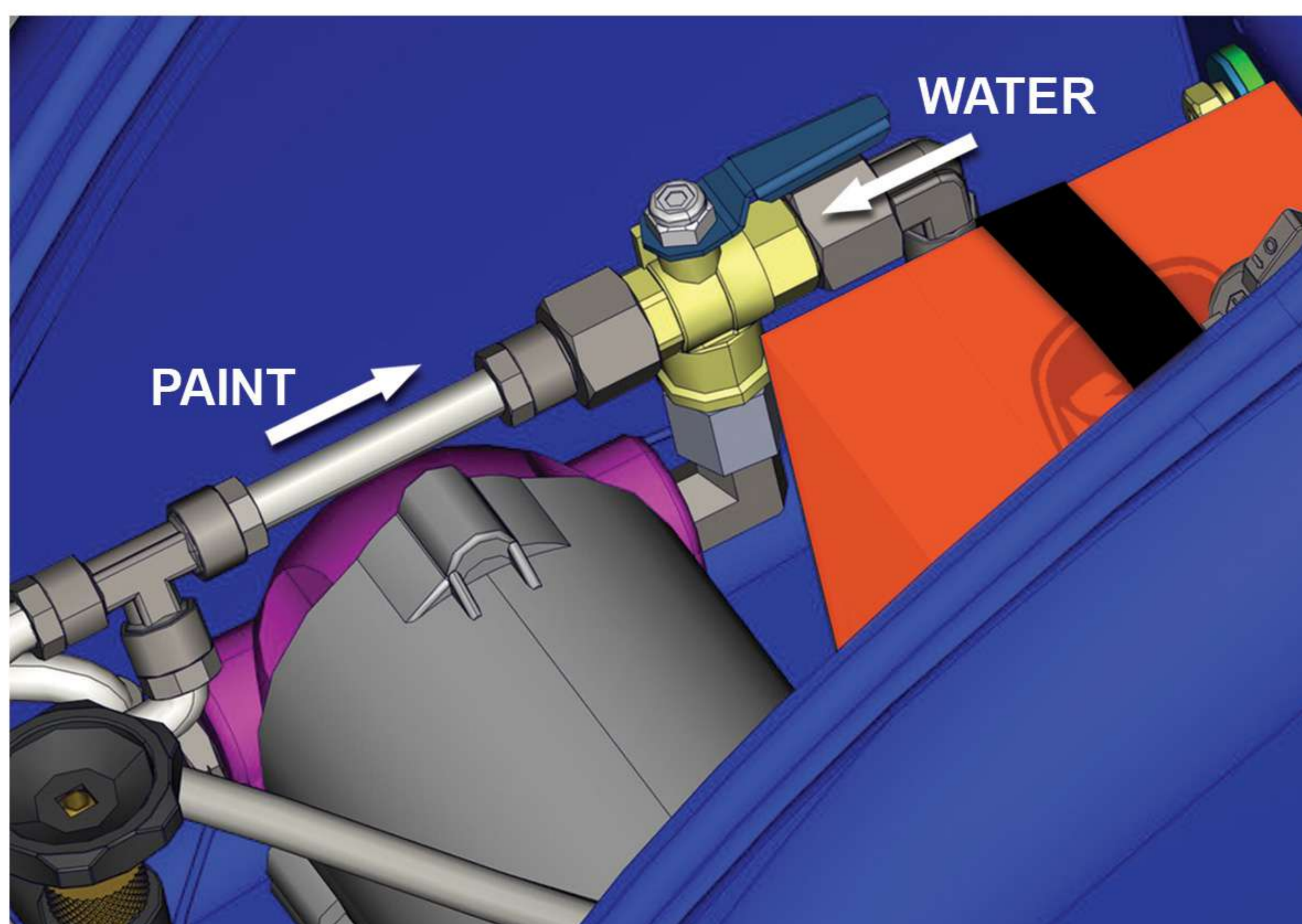

MAINTENANCE ACCESSORIES

These accessories are available from the Fleet Line Markers online store. Visit www.flmuk.com for more details

Fleet Wipes - A tub of beaded hand/machine wipes which help keep your machine free of paint and grime and to keep the marker operating smoothly.

Fleet Ultrasonic Cleaner - The Fleet Ultra Sonic Bath, available as an addition to the Kombi system, is used for thoroughly cleaning small parts which cannot be cleaned effectively using normal methods. The sonic bath is primarily used for the nozzle tip. It is important that the nozzle tip is kept scrupulously clean to provide a well defined line. Other small parts can also be cleaned in the sonic bath such as, nozzle filter and nozzle washer



Paint Bag Collar – Allows the machine to use the paint bag system. The paint bag system is the convenient way of buying paint. Pre-mixed paint with no mess or waste and the paint tank doesn't require washing out. The kit comes with all the necessary pipe work/connector for the conversion.

STOWING THE KOMBI ORANGE LINE MARKER

When the machine has been flushed and cleaned, prepare the Kombi Orange line marker for transport or storage as follows:

1. Squeeze nozzle height adjustment spring collar and slide the nozzle post down to the minimum height.
2. Using the spring collars, slide the line guide disks in, so that they support the nozzle assembly centrally.
3. Loosen knib retainer clip and lift the knib from the tapered post.
4. Park the knib onto the bonnet horn.
5. The Kombi Orange line marker is now ready for transportation and/or storage.



TROUBLESHOOTING

If the Kombi Orange line marker is not producing the perfect line, the table below is to help diagnose and remedy simple issues. The main cause for failure is inadequate cleaning/flushing. It is imperative to keep the paint system free from dried paint particles.

Note: These procedures presume that there is sufficient Fleet paint in the paint tank or bag.

No.	Issue	Cause	Remedy
1	Intermittent line/Pressure gauge flickering	Airlock in paint system	<p>Bleed paint system as follows:-</p> <p>Paint tank system Refer to page 8.</p> <p>Paint bag system Away from the pitch area or have a small container ready to catch paint. Disconnect the paint tube from the back of the nozzle assembly (paint tube on the right hand side when looking on the front of the machine). To release quick connections refer to the section below. Switch the pump ON and allow paint to flow from the tube for 5-10 seconds. Operate the valve on the manifold to purge the bypass system. Turn the pump off. Replace the tube into the nozzle connector.</p>
2	Line striping	<p>1. Nozzle tip contaminated</p> <p>2. Insufficient pressure</p>	<p>a. Remove nozzle and clean in Sonic bath. b. Replace with new nozzle.</p> <p>Increase pressure using pressure adjustment valve on manifold.</p>
3	Low pump pressure	Low battery charge	<p>Use battery monitor to check battery status. Recharge battery.</p>
4	No machine power	<p>1. Low battery charge</p> <p>2. Fuse blown</p>	<p>Use battery monitor to check battery status. Recharge battery.</p> <p>Check blade fuse and replace if necessary.</p>
5	Pressure increasing	Blockage	<p>a. Check nozzle and top hat filter for residue, clean and replace. b. Replace with new nozzle and filter.</p>

Quick connectors

Removal

1. To release a pipe from a quick connector, push on both sides of the blue collar.
2. With the collar pushed in, pull the pipe from the connector.

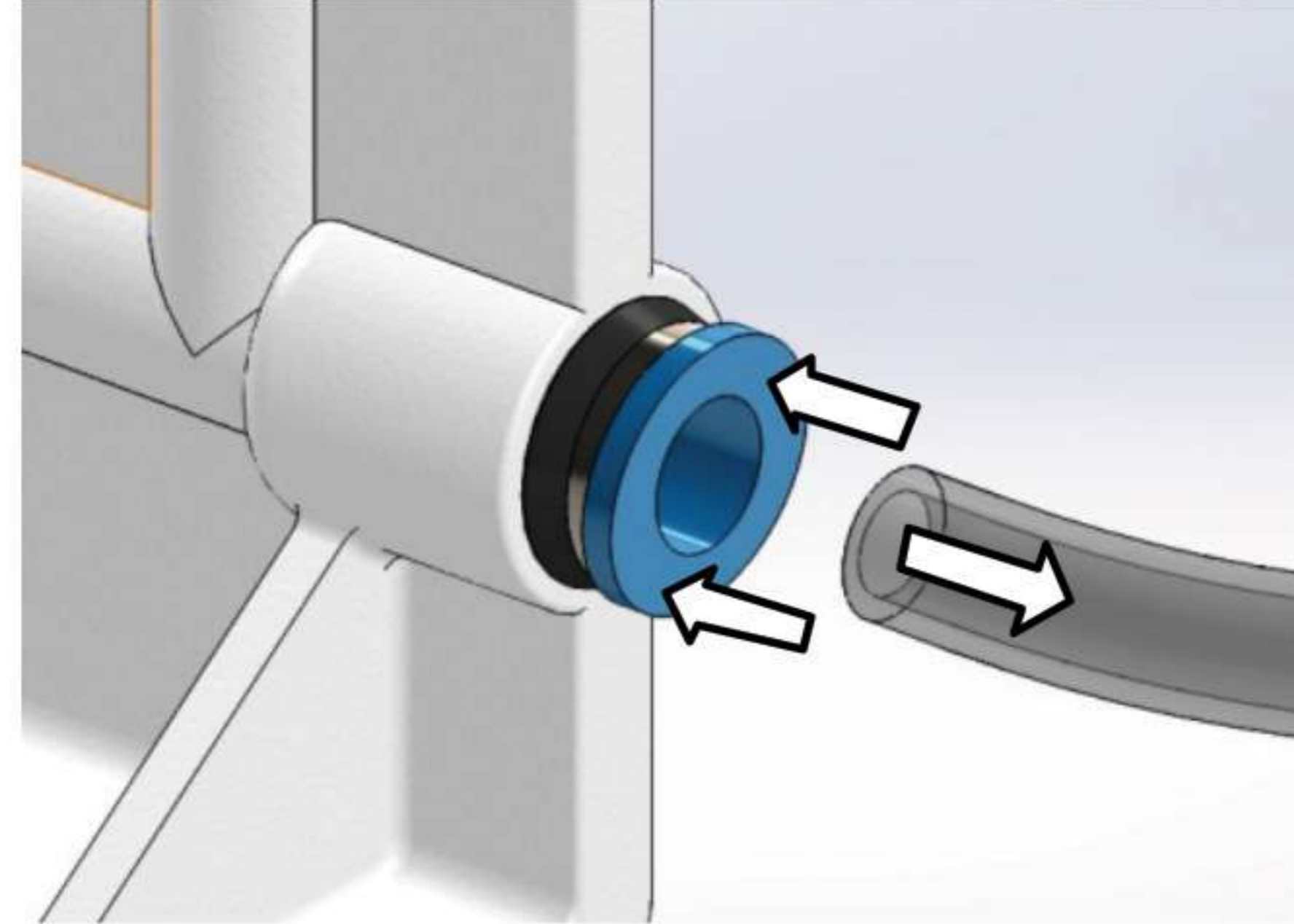
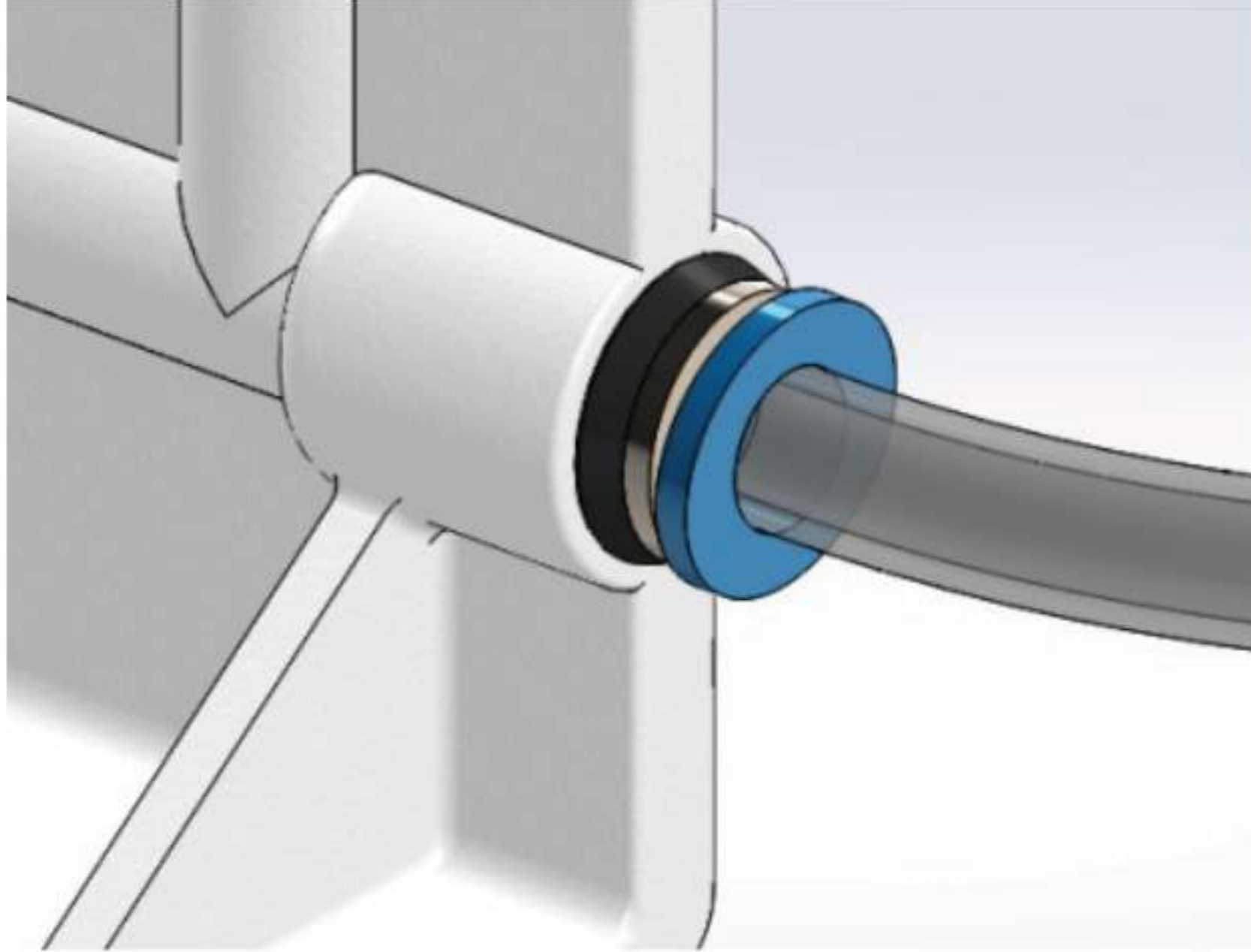

Replacement

1. To replace a pipe into a quick connector, simply push in the pipe. The pipe should be inserted 15 mm to ensure a good connection.

Note: The quick connectors in the manifold and the nozzle are adhered in place and cannot be removed. In the event a quick connector failing in either of these parts, the whole assembly has to be replaced.

Note: Avoid sharp bends close to a quick connector

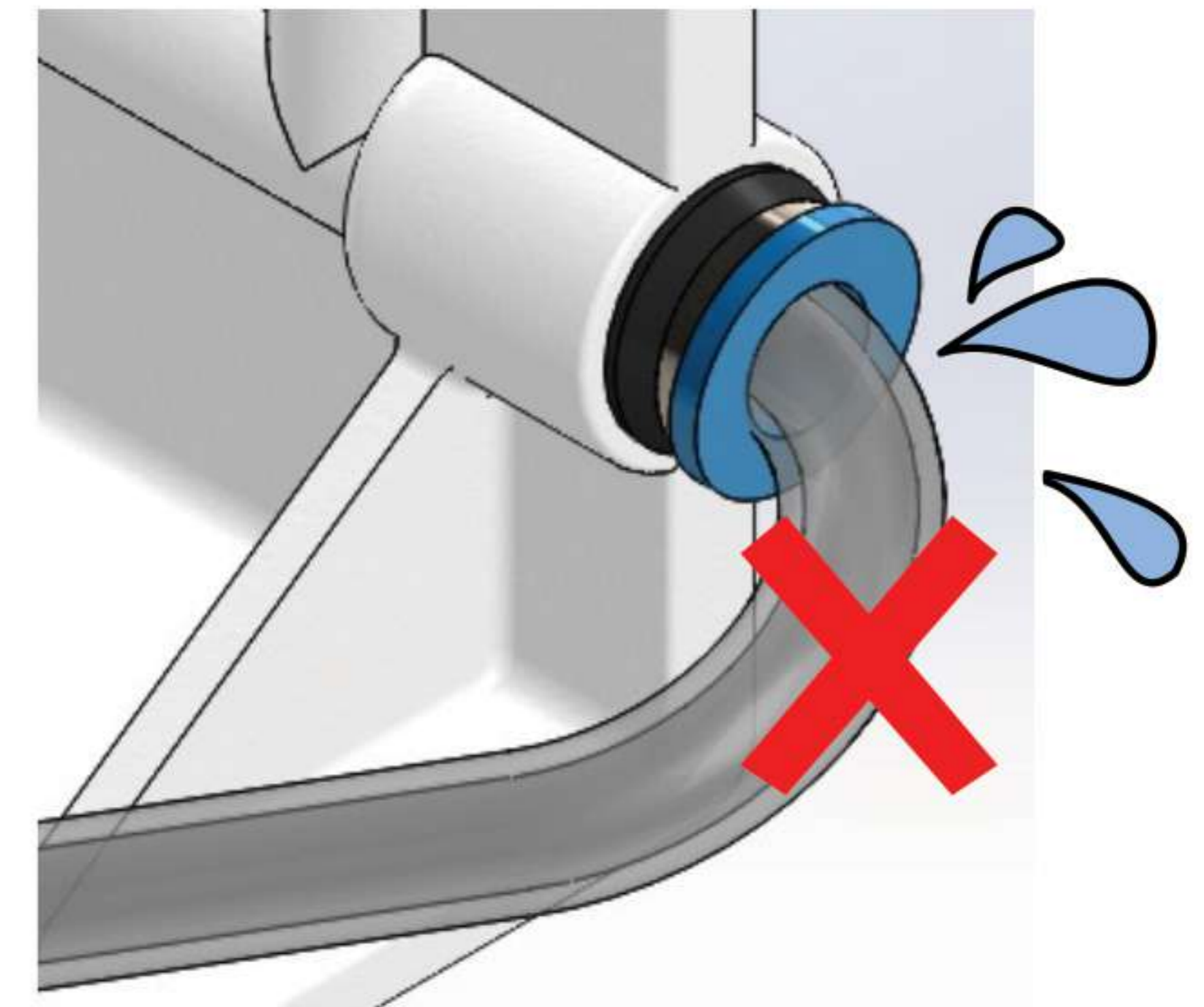

Compression fittings

Removal

1. To release a pipe from a compression fitting use an 12mm spanner to loosen the end cap.
2. Pipe can be pulled out.
3. The use of two spanners maybe required if the compression fitting is to be replaced.

Drain caps

A spanner is provided to aid tightening and removal of the drain caps.

Diagrams

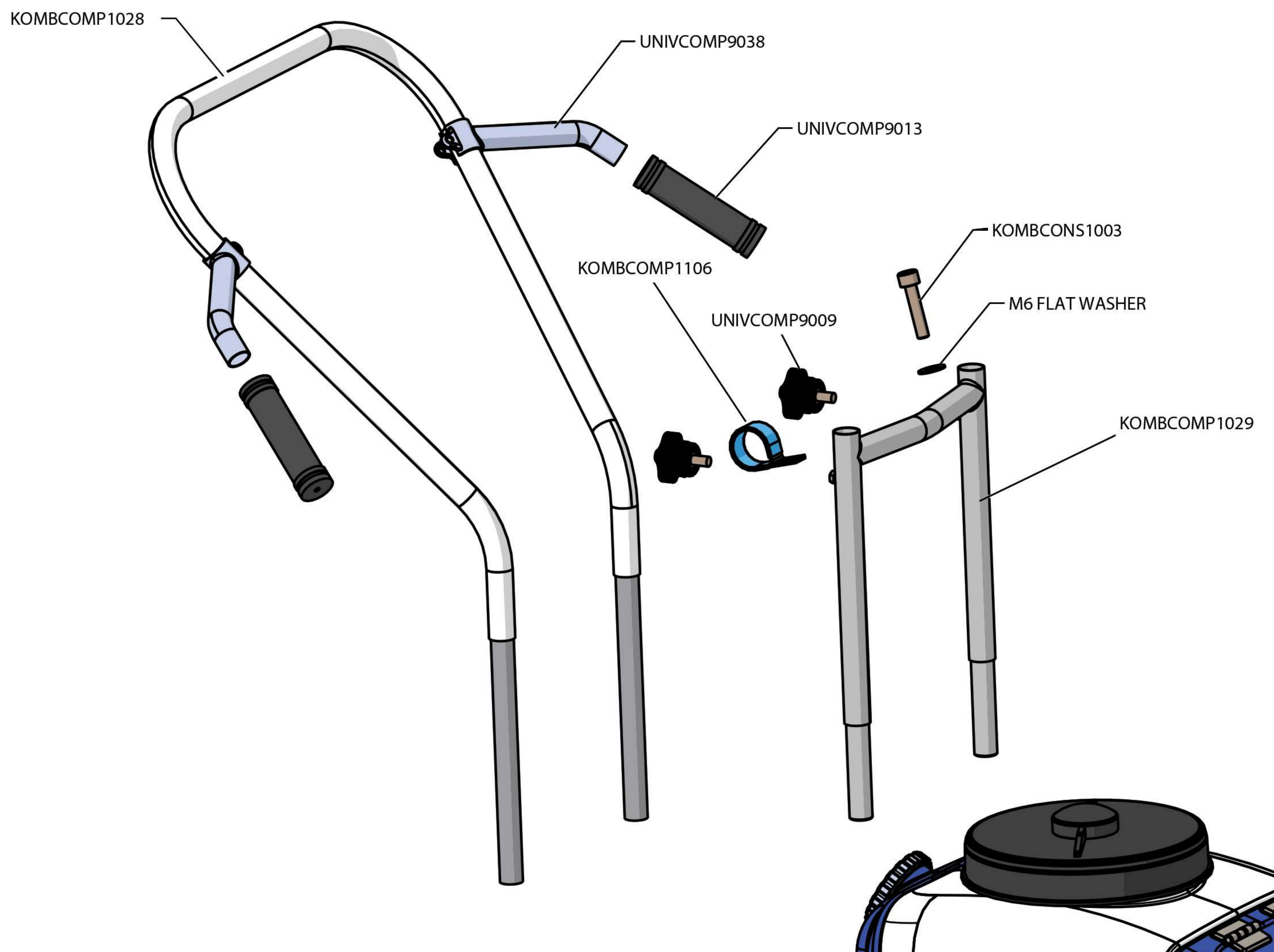

PART NO

PART NAME

KOMBCOMP1028	Handle Bar Top Section
KOMBCOMP1029	Handle Bar Bottom Section
KOMBCOMP1106	Steel P Clip 22mm
KOMBCONS1003	M6 x 25 Socket Cap Head Screw
UNIVCOMP9009	M6 Thumb Screw
UNIVCOMP9013	Rubber Handle Grips
UNIVCOMP9038	Bar Ends (Pair)
UNIVCONS9058	M6 x 20 Flat Repair Washer

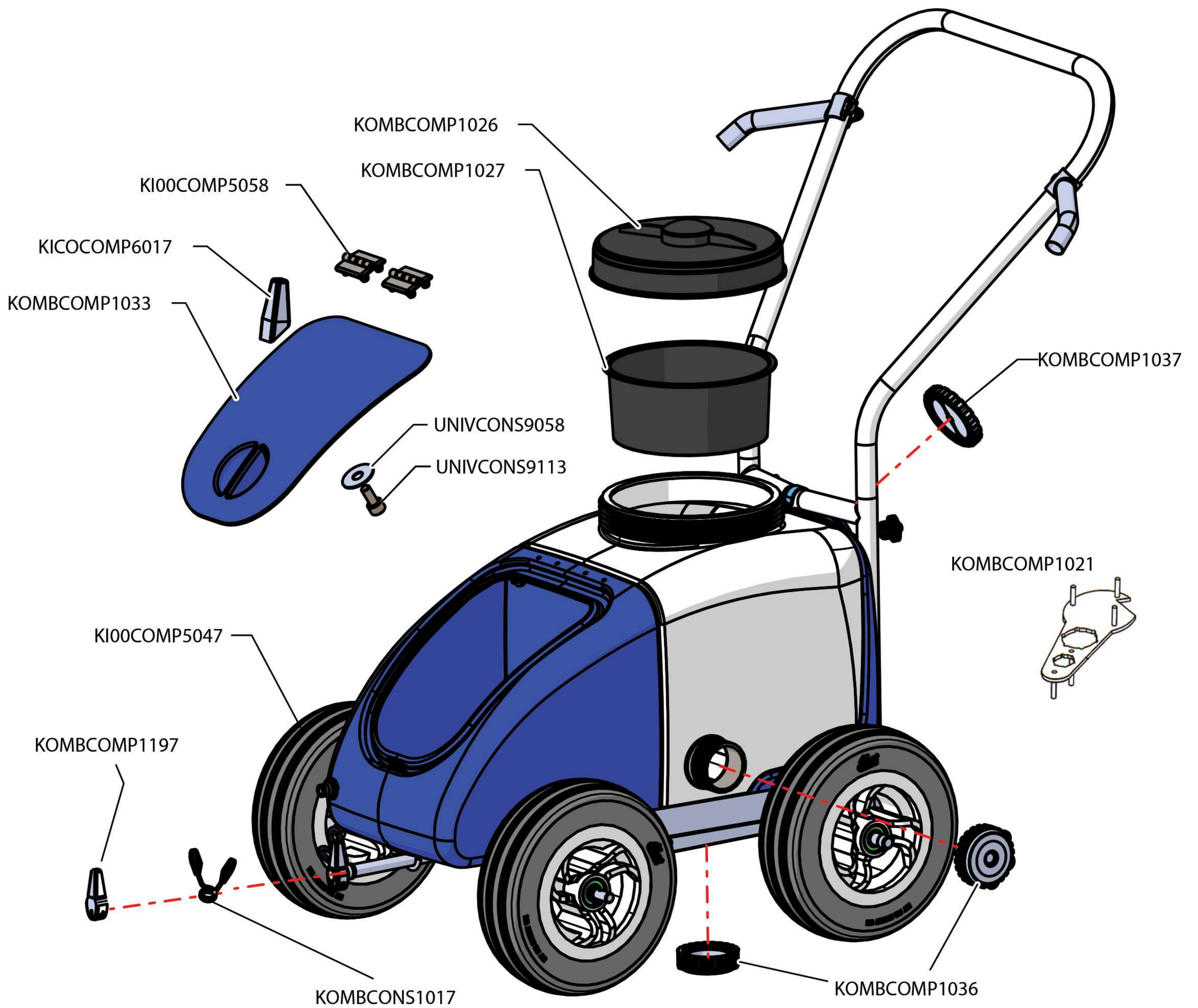

PART NO

PART NAME

KI00COMP5047	Wheel & Solid Foam Tyre
KI00COMP5058	Bonnet Hinge (Sprung)
KICOCOMP6017	Bonnet Horn
KOMBCOMP1021	Spanner
KOMBCOMP1026	Tank Lid
KOMBCOMP1027	Tank Filter
KOMBCOMP1033	Bonnet
KOMBCOMP1036	Plastic Drain Cap
KOMBCOMP1037	2 Inch Vented Water Cap
KOMBCONS1017	15mm Retaining Clip for Knib
UNIVCONS9058	M6 x 20 Flat Repair Washer
UNIVCONS9113	M6 x 12 Socket Cap Head Screw

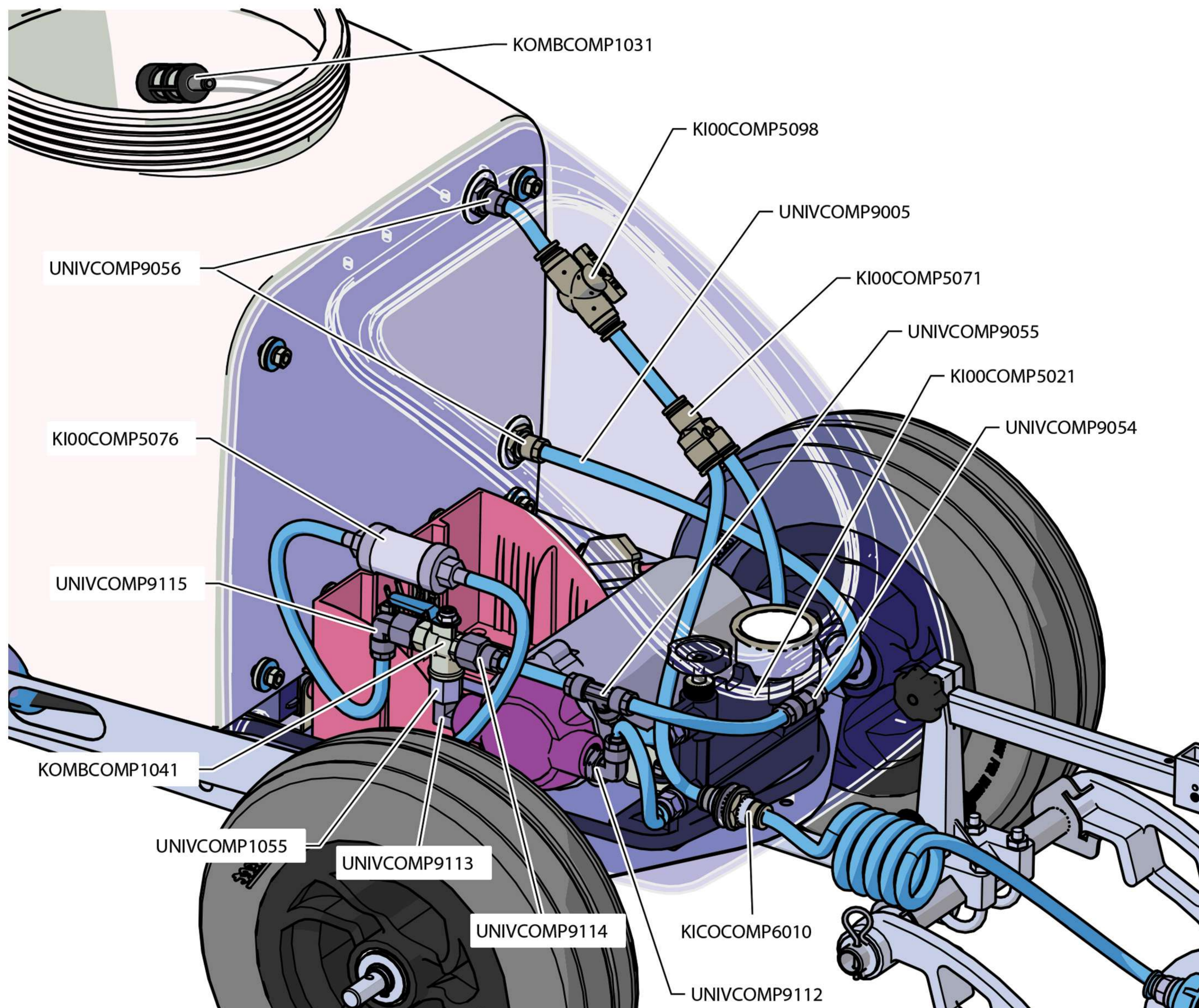
**PART NO****PART NAME**

KI00COMP5021	100psi Manifold Complete
KI00COMP5071	Y Shaped Connector 8mm
KI00COMP5076	6mm Chrome Inline Filter Glass Tube
KI00COMP5098	Push Fit Hand Valve
KICOCOMP6010	Hose Quick Connection Bulkhead Fitting
KOMBCOMP1031	Tank Filter
KOMBCOMP1041	Paint Water Tap 3 Way
UNIVCOMP1055	1/4 BSPT M - 1/4" BSP F Brass
UNIVCOMP9005	Clear PVC Hose 8mm x 5mm
UNIVCOMP9054	Compression Fit Inline Valve
UNIVCOMP9055	Compression Fit T Piece
UNIVCOMP9056	Quick Release Compression Fit Bulkhead
UNIVCOMP9112	3/8 Elbow Connector NPT
UNIVCOMP9114	1/4 BSP Female / 8mm Compression Fit Adapter
UNIVCOMP9113	1/4 Male/Male Elbow NPT
UNIVCOMP9115	Female Pipe Elbow
UNIVCONS9086	6mm Male Bullet Red Terminal Connector (not illustrated)
UNIVCONS9087	6mm Female Red Receptacle Terminal Connector (not illustrated)

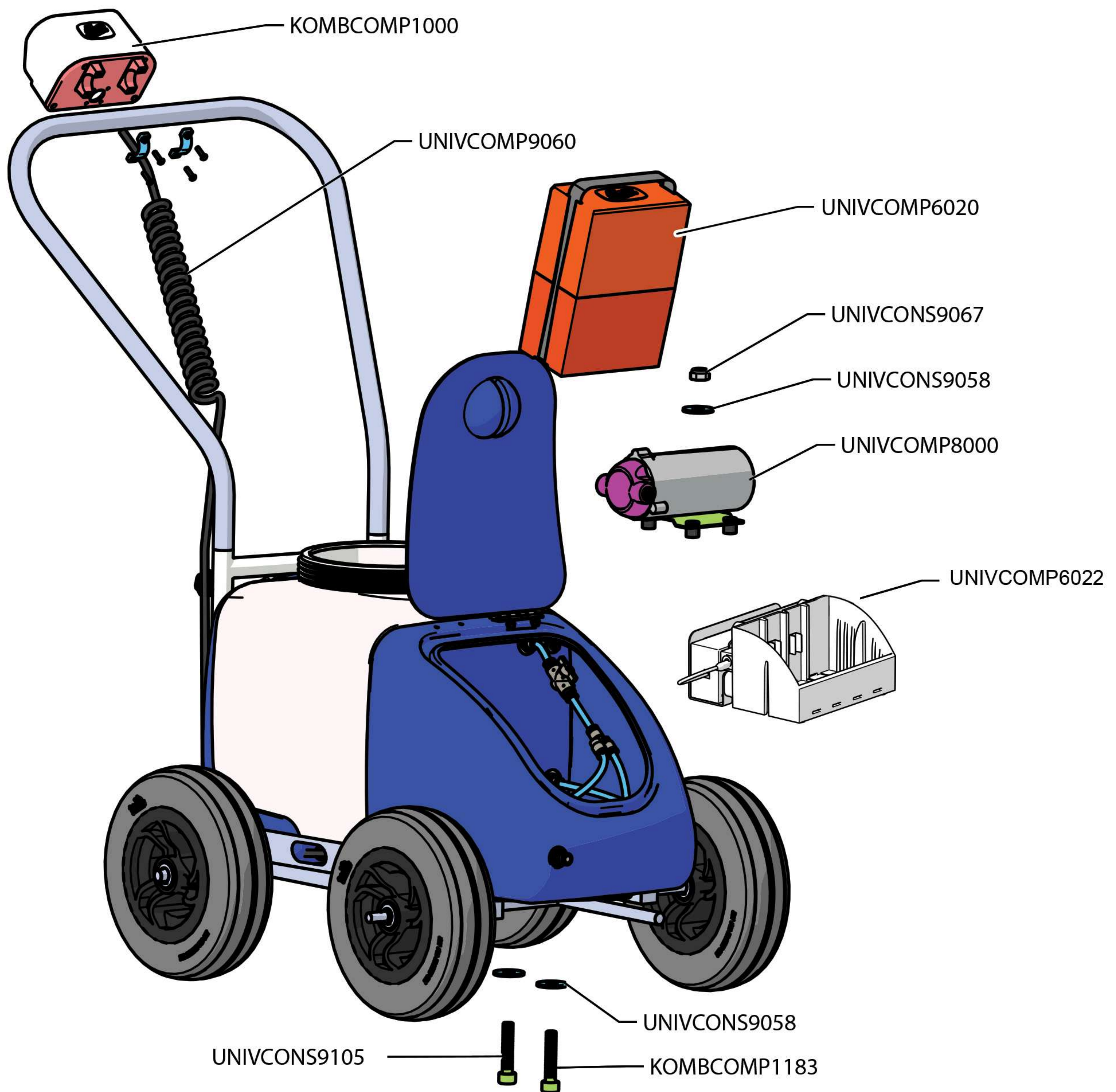

PART NO	PART NAME
KOMBCOMP1000	Control Panel
KOMBCOMP1183	M6 x 50 Socket Cap Head Screw
UNIVCOMP6020	Docking Battery
UNIVCOMP6022	Battery Charging Station
UNIVCOMP8000	24v Diaphragm Pump
UNIVCOMP9060	8 Core Coiled Cable
UNIVCONS9058	M6 x 20 Flat Repair Washer
UNIVCONS9067	M6 SS Hex Nyloc Nut
UNIVCONS9105	M6 x 30 Socket Cap Head Screw

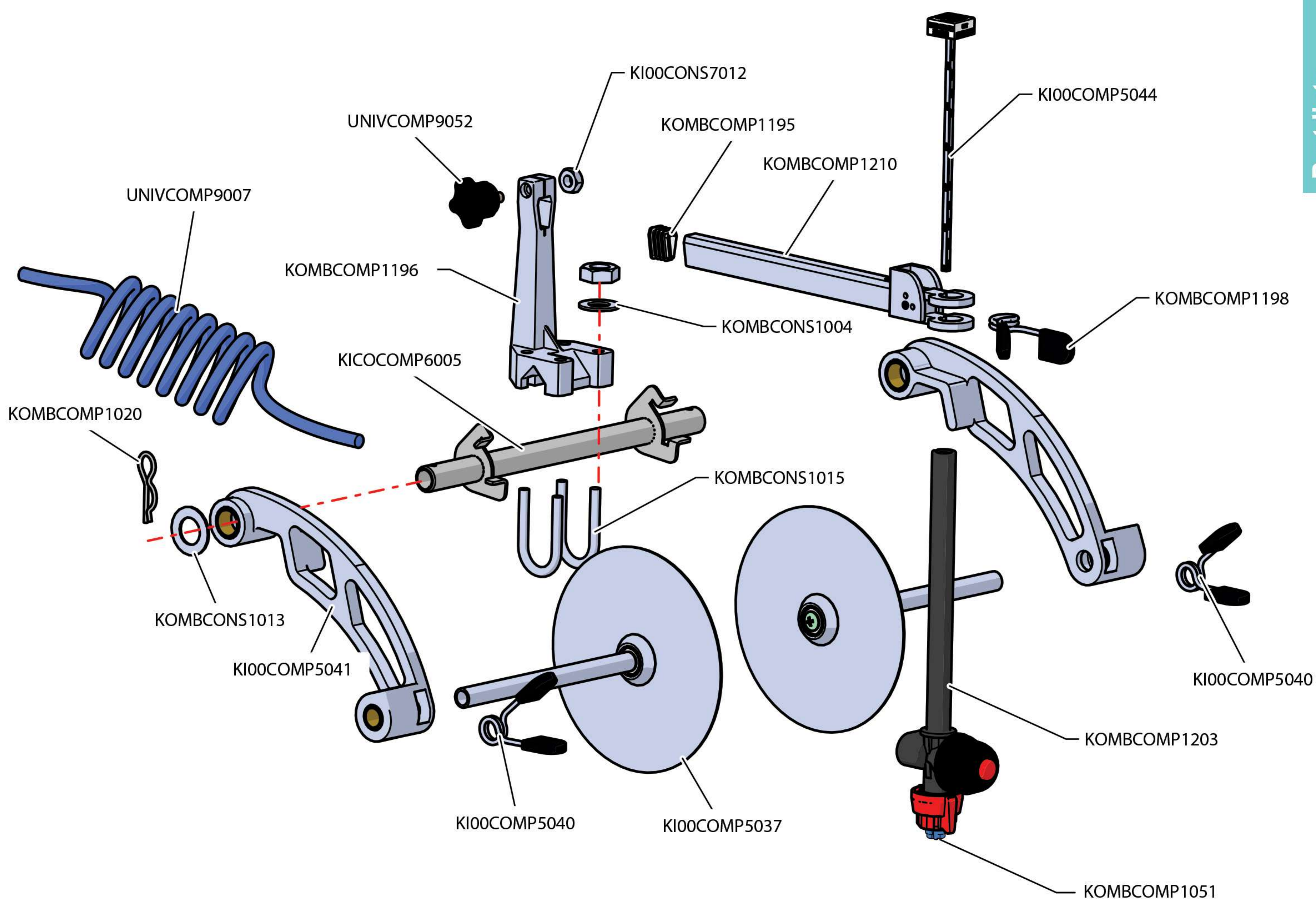

PART NO

PART NAME

KI00COMP5037	Guide Assembly Inc Disk & Shaft
KI00COMP5040	Spring Collar (Black Rubber)
KI00COMP5041	Metal Guide Arms Set (Left & Right)
KI00COMP5044	Ruler Assembly
KI00CONS7012	M5 Hex Full Nut
KICOCOMP6005	Line Guide Pivot Bar Assembly
KOMBCOMP1020	Steel R Clip 42mm
KOMBCOMP1051	Nozzle Tip Blue 110°
KOMBCOMP1195	Extruded Tube End Cap
KOMBCOMP1196	Support Pillar
KOMBCOMP1198	Spring Clip 14mm ID
KOMBCOMP1203	Complete Nozzle Assembly
KOMBCOMP1205	Wheeled Knib Standard (Whole Assembly)
KOMBCOMP1210	Extruded Tube Assembly
KOMBCONS1004	M6 Form A Flat Washer
KOMBCONS1013	17.1mm ID x 30mm OD x 0.9mm Washer
KOMBCONS1015	M6 U Bolt (inc nuts)
UNIVCOMP9007	1m Coiled Blue Hose
UNIVCOMP9052	M5 x 20 x 25mm Hand Wheel Thumb Screw

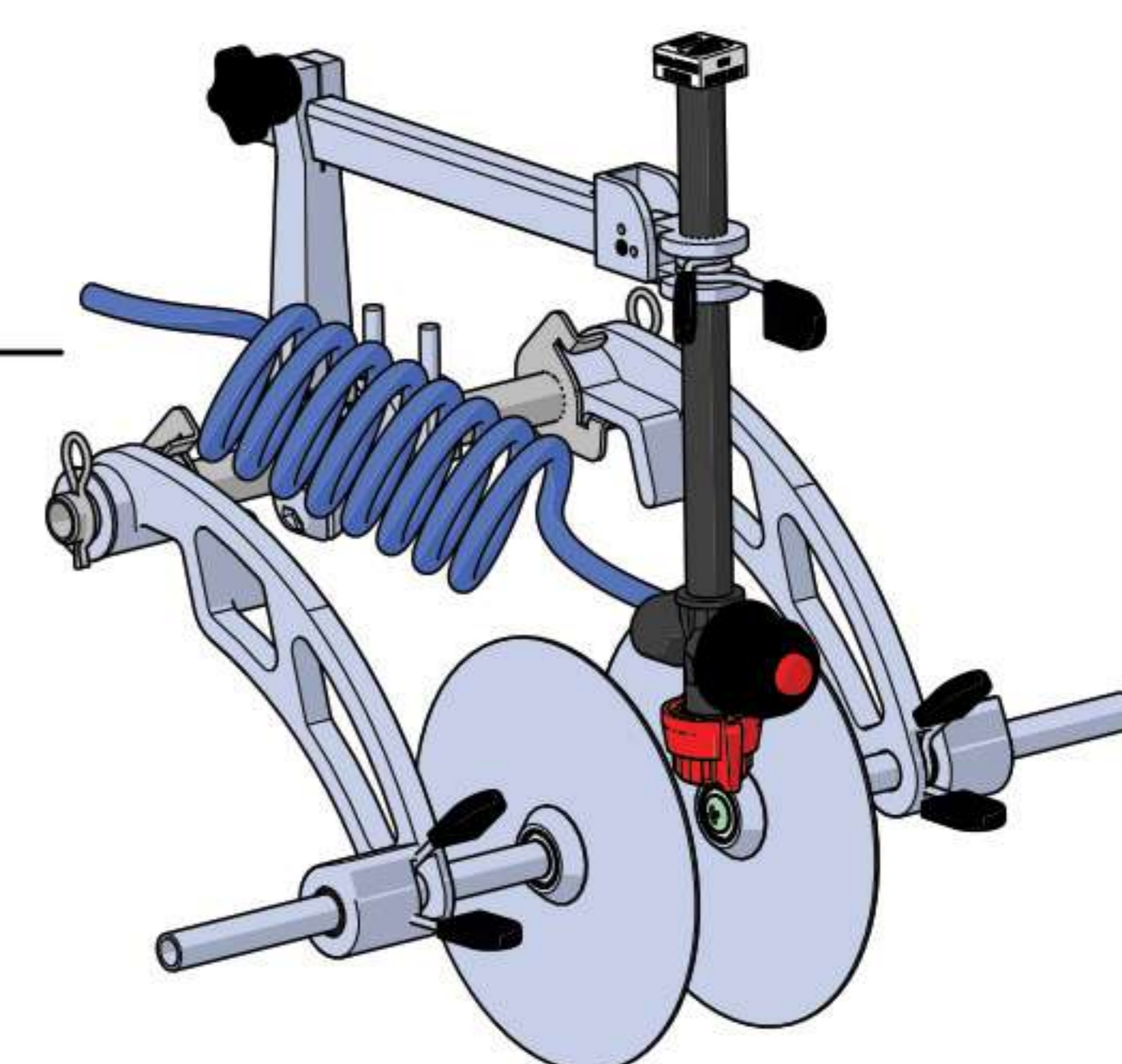

Specification

Machine

Length: 127cm Width:74cm Height: 109cm

Net Weight : 27kg

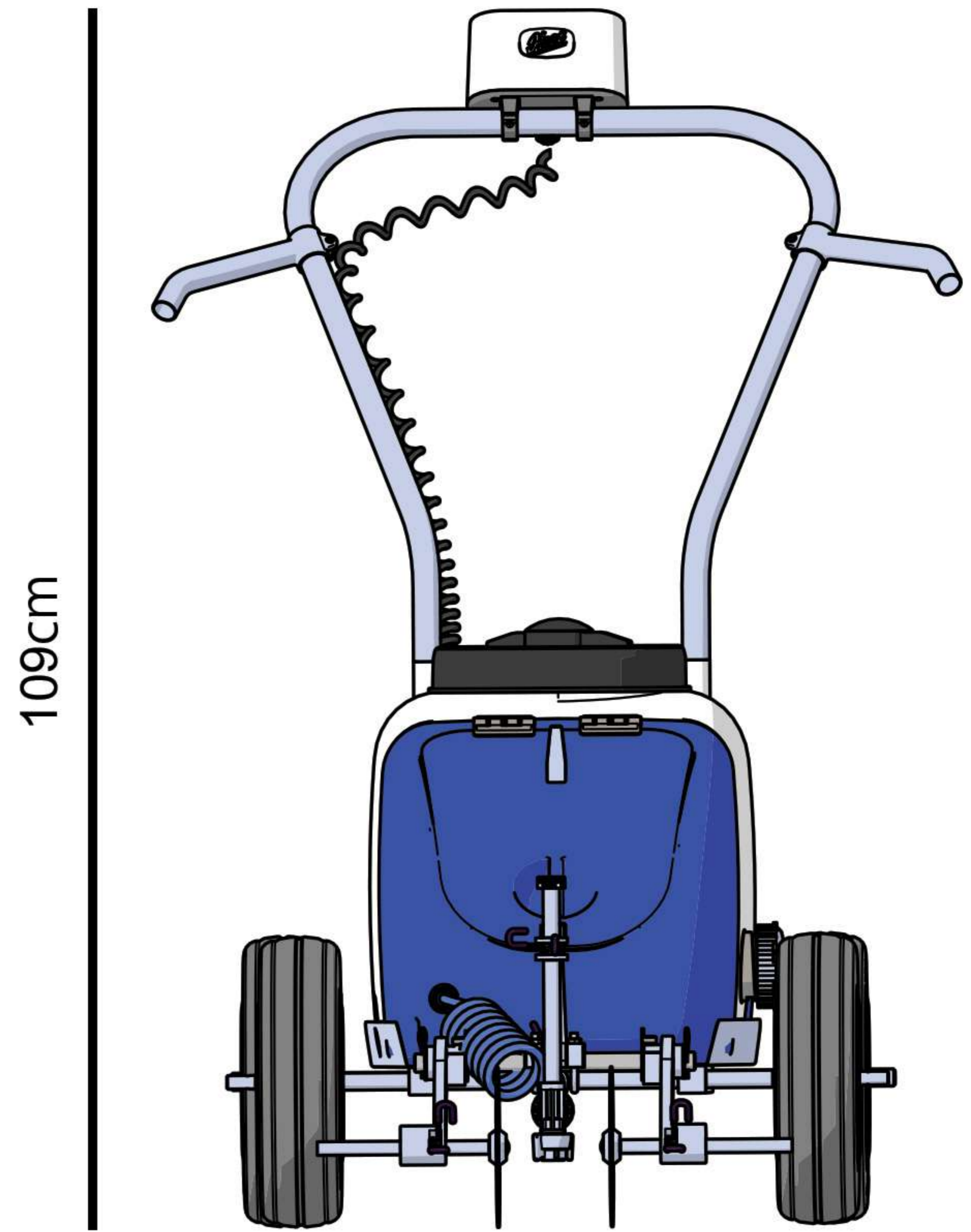
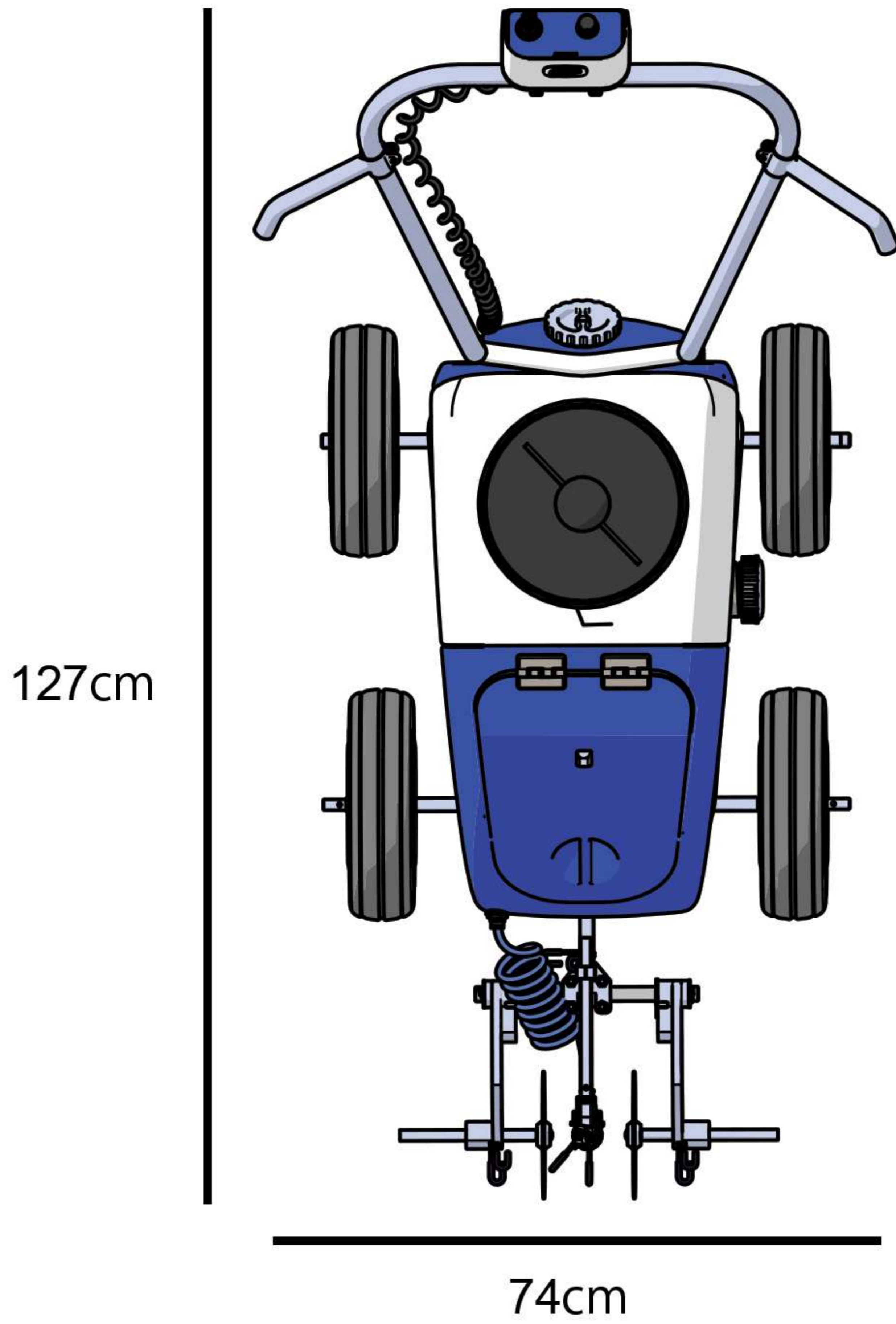

Package

Length: 77cm

Width: 64cm

Height: 57cm

Net weight: 29kg

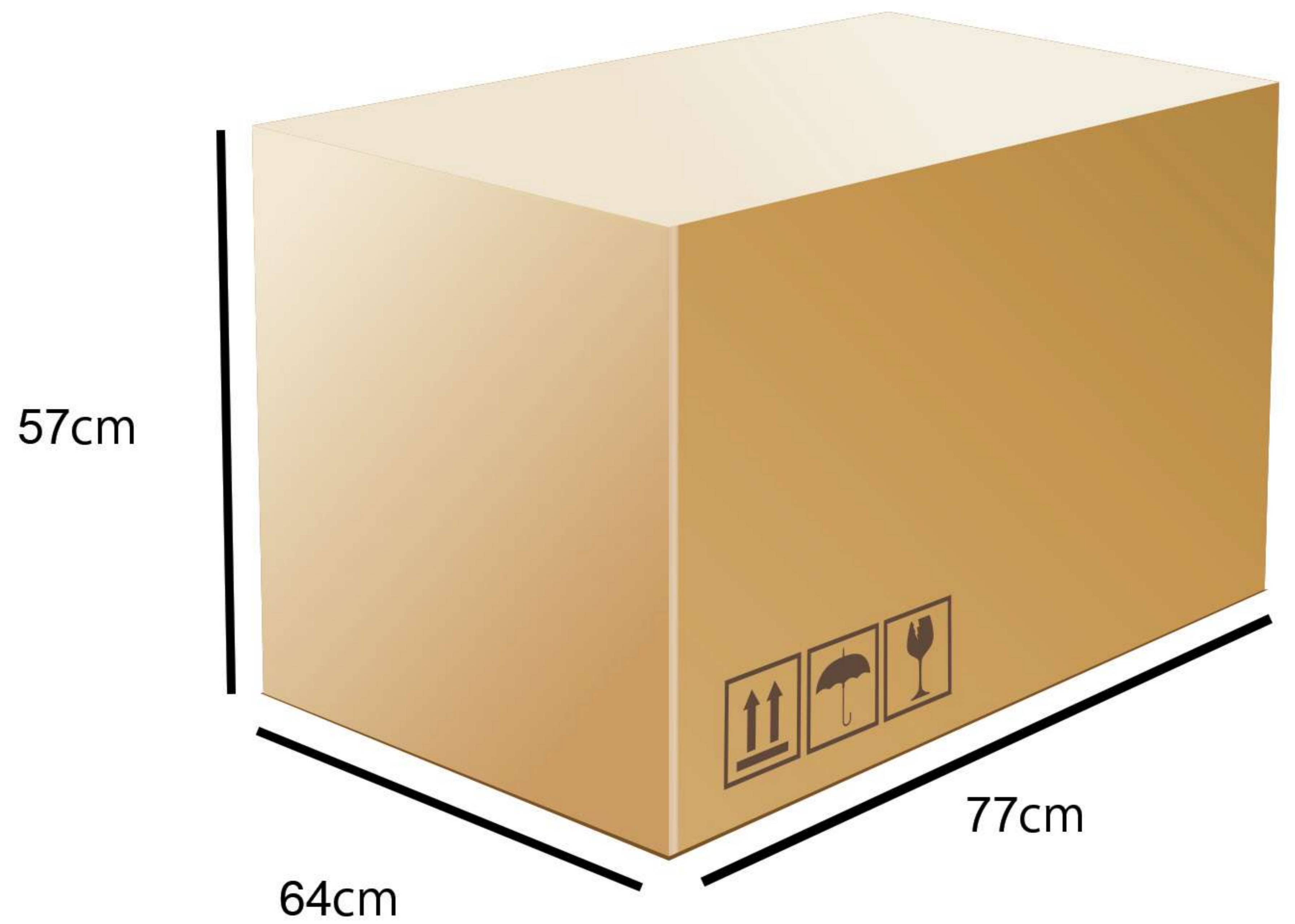

WARRANTY

The Kombi is capable of producing outstanding lines.

The Kombi pump has been matched for ultimate performance and reliability when used with Fleet paint.

The Kombi is guaranteed against any manufacturing defects. Any manufacturing defects will be corrected/replaced as soon as possible.

The Kombi is not guaranteed against normal wear and tear.

This guarantee does not interfere with the customer's statutory rights.

The pump is guaranteed for 12 months when using Fleet paint.

Machine must be registered by filling in the warranty card at the following url:

www.flmuk.com/kombi-warranty

Please fill out the table below for quick reference should you require

Kombi Serial Number :

Date purchased :

Where Purchased :