

K



www.fleetaustralasia.com.au

Turfmate Limited 39 Winterton Rd, Clayton VIC 3168. Australia

Tel: 1300 184 400 Fax: 954 00909

Ki OPERATION

UNPACKING AND CHARGING THE BATTERY

1. Carefully remove the Ki and accessories from the box and packaging.
2. Position the Ki near a 230/240 V ac power supply where the battery can be charged.
3. Charge the battery using the supplied charger.

CAUTION: Only use the supplied charger. Use of other equipment may cause fire or damage the battery.

4. Align the keyways on the plug and socket, push the plug into the socket and rotate the locking collar clockwise.

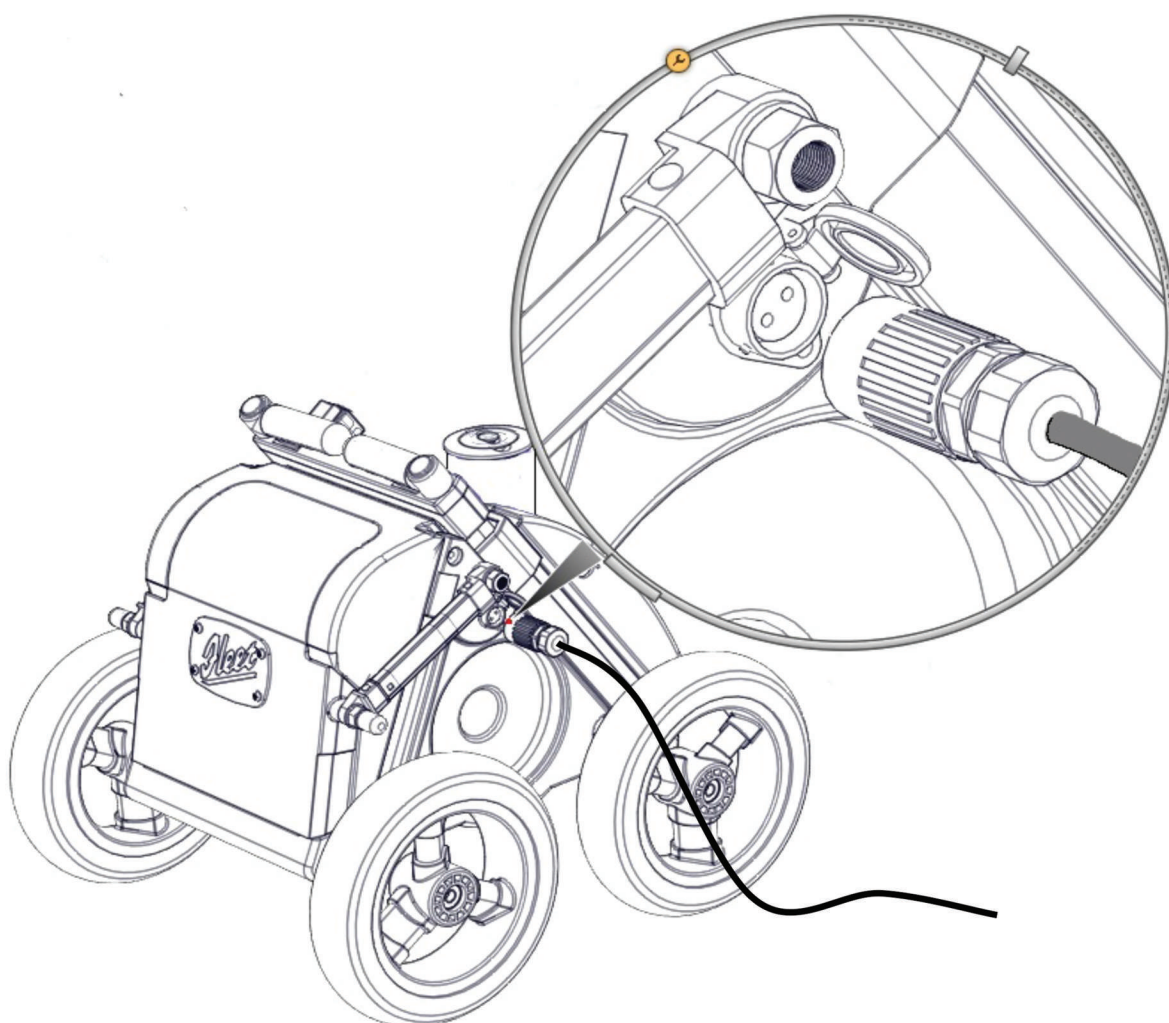

Fig 1 Charging socket position

5. When charging, the LED on the charger illuminates red. When the battery is fully charged, the LED illuminates green. To test the battery charge status, press the button on the battery monitor. All three green LEDs lit indicate that the battery is fully charged.



Fig 2 Battery status indicator

GETTING THE KI READY FOR OPERATION

Extending the handle bars

1. Pull back the rear cover to the full extent and rotate it over handles and rest it on the bonnet.

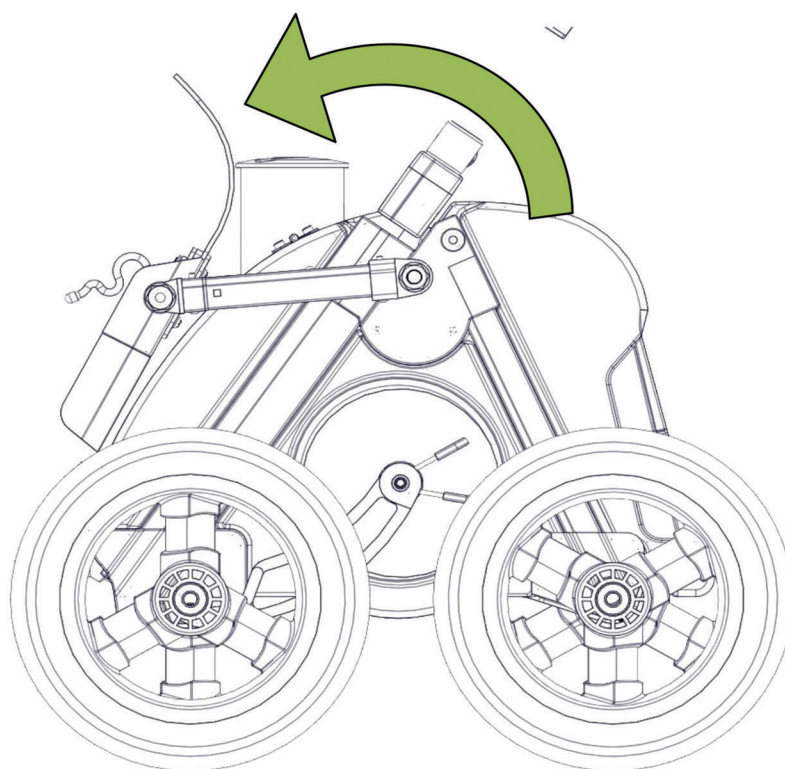

Fig 3 Rear cover resting on the bonnet

2. Depress the round buttons on the handle grips and rotate handle grips to the preferred working position.

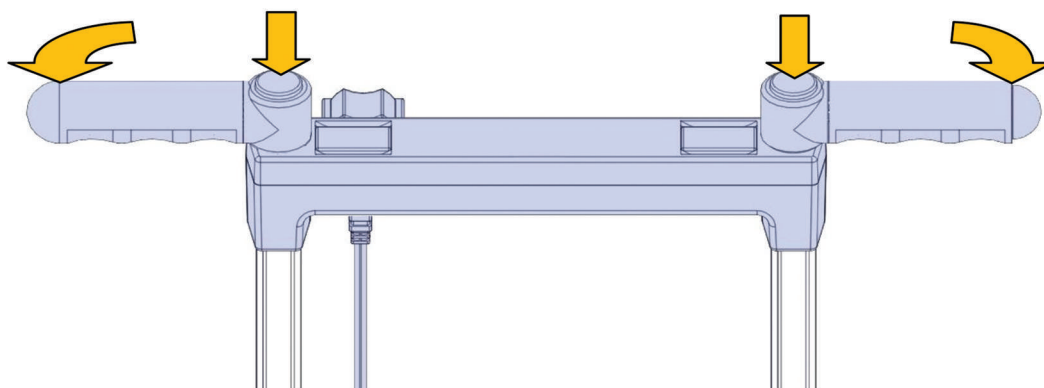

Fig 4 Handle bar rotation buttons

3. Depress rectangular buttons and raise handle bar to required stop height (3 positions provided)

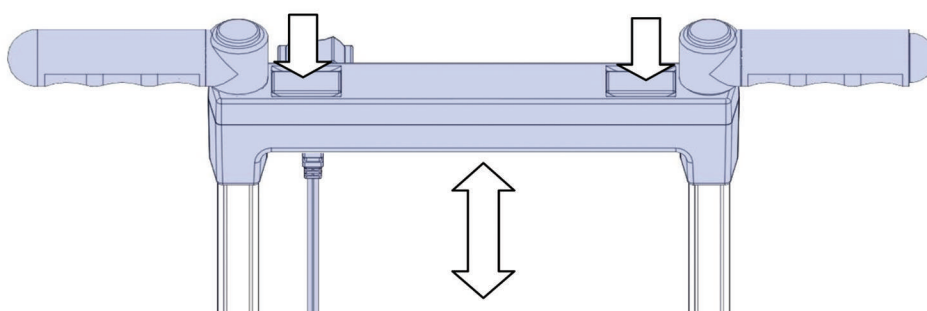

Fig 5 Handle bar extending/collapsing

4. Pivot the rear cover up and clip it onto the handle supports.

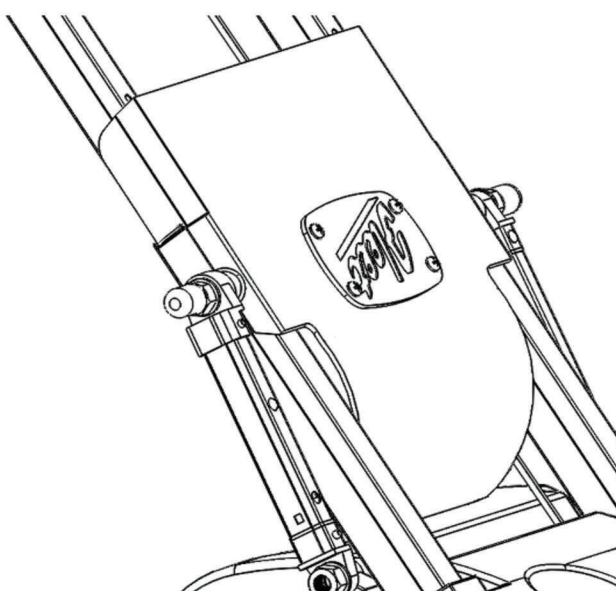

Fig 6 Rear cover positioned on handle supports.

Filling the nozzle flush reservoir

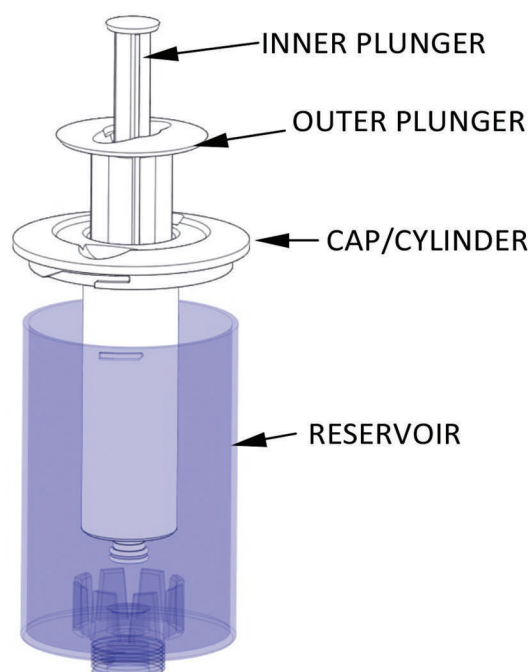

Fig 7 Nozzle flush components

With a quarter turn anti-clockwise, remove the complete cap/cylinder plunger section of the nozzle flush system. Using only clean water, fill the water flush reservoir to approximately 1" (25 mm) from the top. Replace the plunger section.

Remove connector from bottle

Unscrew the bottle to reveal the paint bag connector. Stow the bottle in the cut out provided.



Fig 8 Paint bag connector

Preparing the paint bag

Holding the paint bag in two hands, one hand at the top and one hand at the bottom, gentle rock the bag to and fro five or six times.

Plain cap foil sealed bags

With the bag held with the cap uppermost, remove the cap and peel off the foil seal. Fit a cap with the integral hydraulic connector.

Hydraulic connector cap bags

Paint bags fitted with the integral hydraulic connector in the cap can be fitted directly onto the paint hose connector

Connecting the paint bag



Fig 9 Connecting the paint bag

1. Lay the paint bag at the rear of the Ki with the connector of the paint bag adjacent to the paint hose connector. Pull out the connector.
2. Open the wings of the connector and push it on to the hydraulic spout on the cap. Close the wings on the connector to secure the coupling.
3. Hang the paint bag from the hooks on the underside of the rear cover.
4. Allow the excess tube to rewind into the Ki.

Deploying the nozzle assembly

1. Open the bonnet.
2. Pull out telescopic nozzle arm to its full extent.

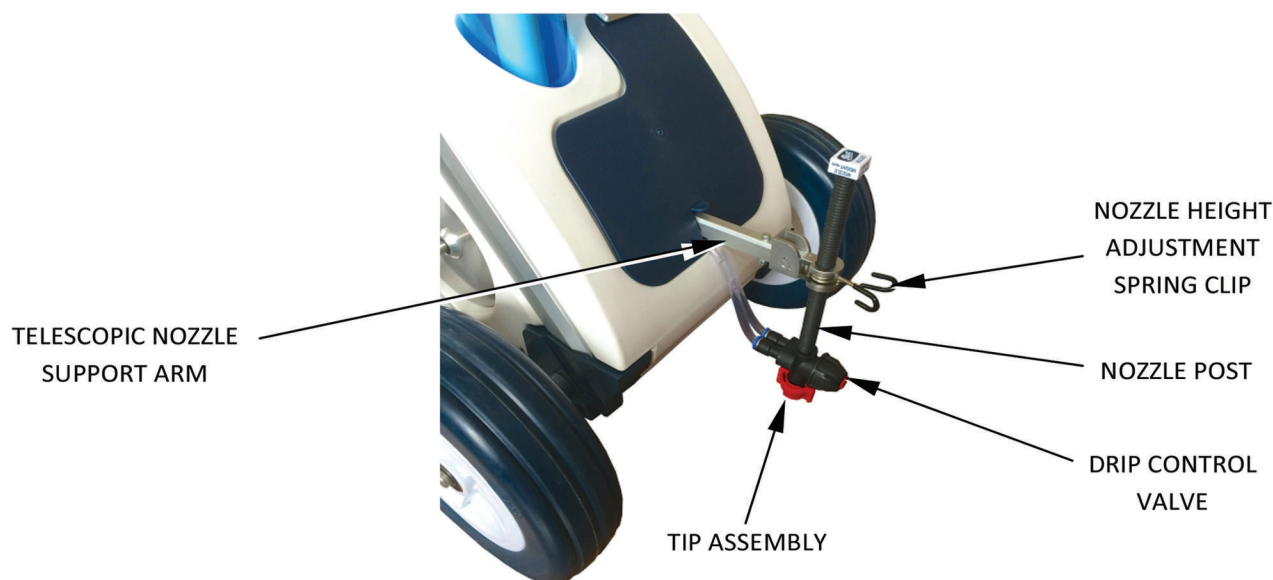

Fig 10 Nozzle arm components

3. Hinge the nozzle post to the vertical position and locate the telescopic arm in the notch at the centre of the bonnet opening. With reference to the table under the bonnet, adjust the nozzle height using the adjustment spring clip for the desired line width. A ruler is provided in the nozzle post.
4. The table below gives approximate nozzle height for a range of line widths. This is only intended as a guide. The operator must observe the spray pattern and adjust the nozzle height to form a good line for the local conditions.

Line width		Nozzle height above top of grass/ surface to be marked	
		Initial marking (42 psi)	Over-marking (30 psi)
50 mm	2 inches	20 mm	25 mm
75 mm	3 inches	30 mm	37 mm
100 mm	4 inches	40 mm	50 mm
125 mm	5 inches	50 mm	62 mm
150 mm	6 inches	60 mm	75 mm

Table 1 Nozzle height for Line width

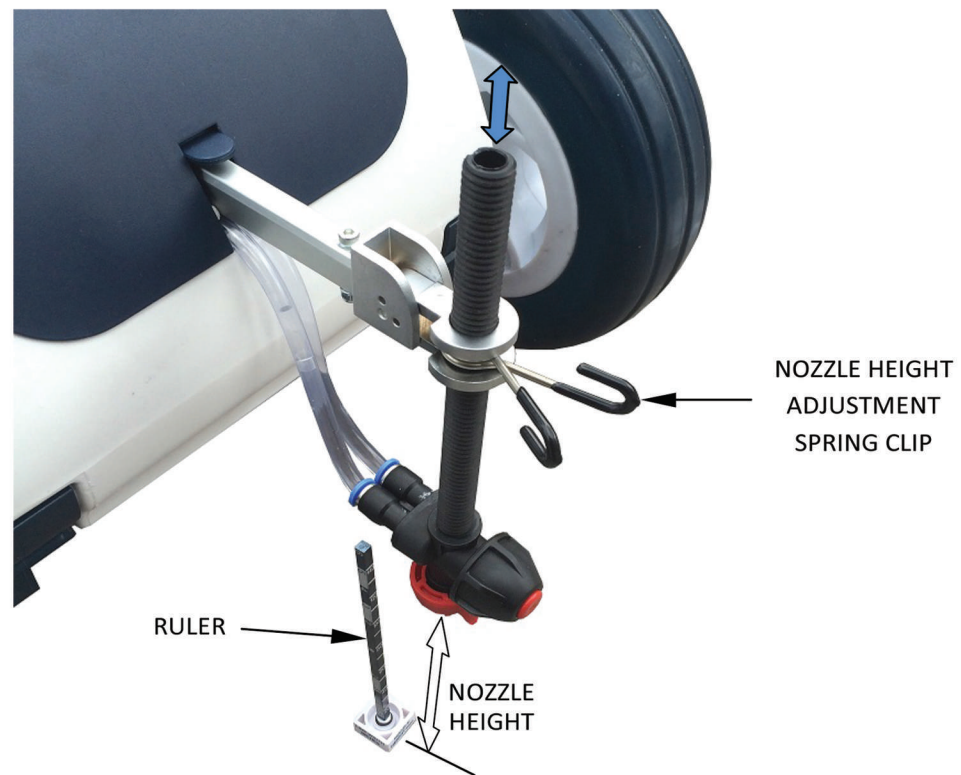

Fig 11 Ruler / nozzle height adjuster

Setting the line width

1. Squeeze the tabs on the spring collars together and pull the line forming disks out from the parked position at either side of the body.
2. Pivot the line forming disks forward and rest the disks on the ground.
3. Using the ruler in conjunction with the line width/nozzle height table, adjust the line forming disks for the desired line width and adjust the nozzle height with the spring clip on the nozzle post.

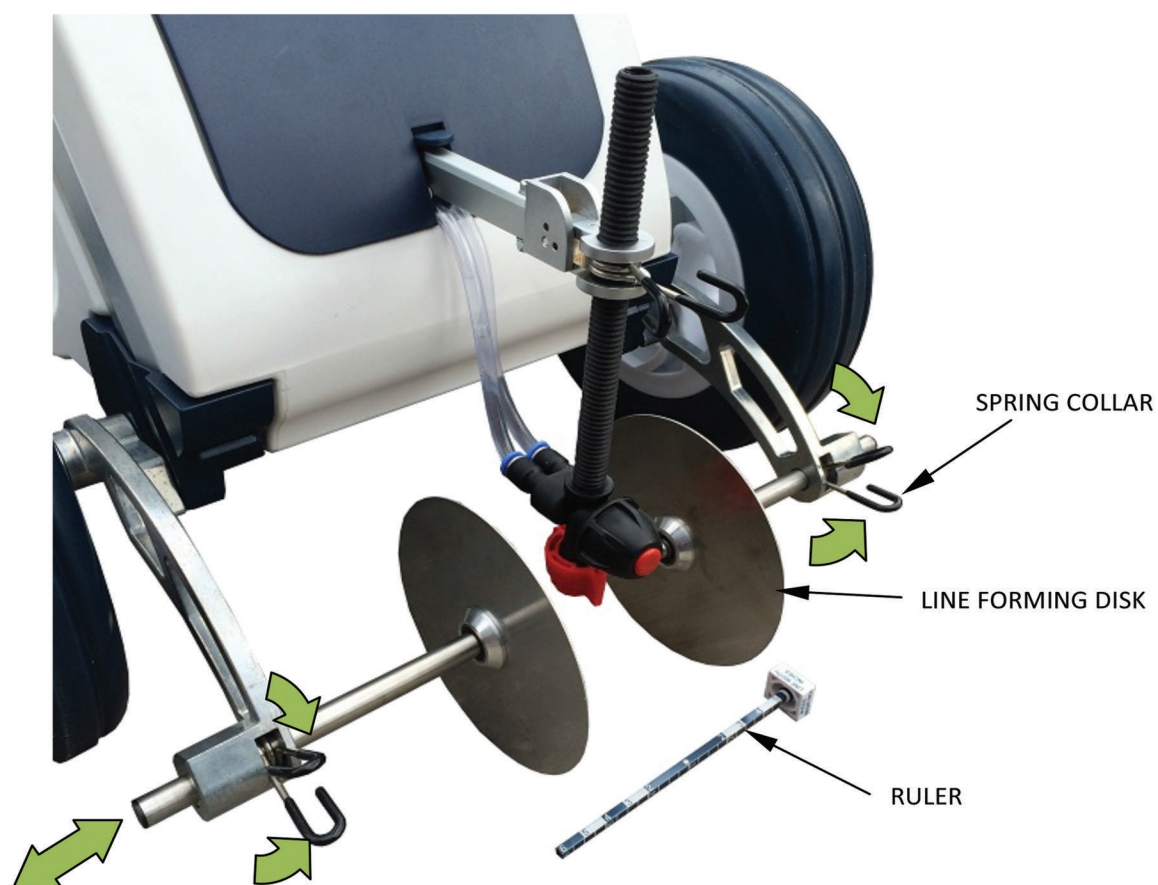

Fig 12 Setting the line width

4. When the nozzle is set to the correct height, arrange the paint and water pipes in the cut out in the body below the nozzle arm.

IMPORTANT

When arranging the two pipes, ensure that the nozzle is positioned in the centre of the guide disks.



Fig 13 Illustration showing the hose arrangement

LINE MARKING WITH KI

WARNINGS - HIGH PRESSURE

1. THE KI HAS A WORKING PRESSURE OF UP TO 60 psi. DO NOT OPEN ANY HOSE JOINTS WHILE THE PUMP IS OPERATING.
2. BEFORE EACH USE, CHECK THAT THERE IS NO EVIDENCE OF PAINT DISCOLOURATION IN THE CLEAR NOZZLE FLUSH TUBE. THIS INDICATES A FAULTY CHECK VALVE WHICH COULD RESULT IN THE INNER NOZZLE FLUSH PLUNGER BEING EJECTED AT HIGH VELOCITY. DO NOT USE THE MACHINE. REPLACE THE NOZZLE ASSEMBLY.

Setting the pressure

1. The pressure of the spray can be adjusted for different applications. The two common settings are as follows:
 - 30 psi for over marking previously marked pitches
 - 42 psi for new marking

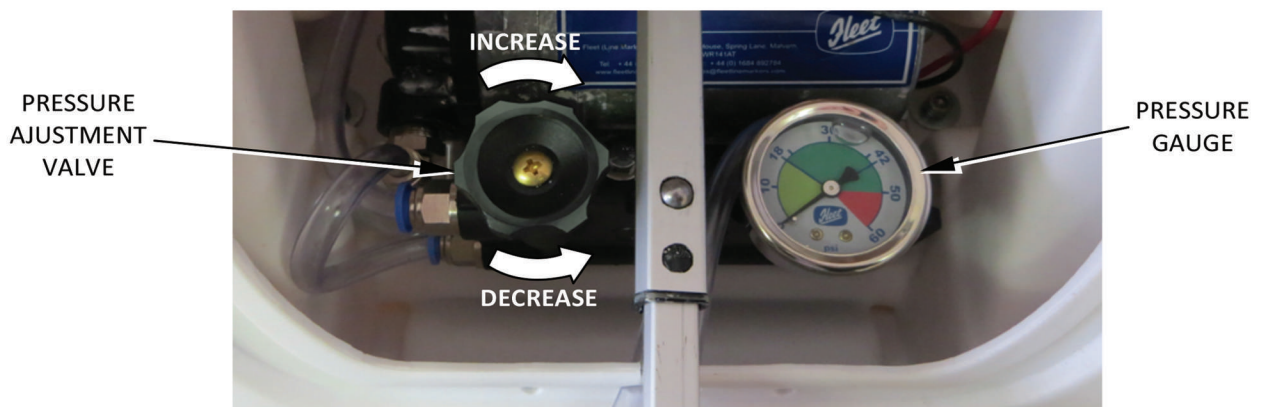

Fig 14 Adjusting the spray pressure

Notes:

1. The lower the pressure, the greater the paint economy. Both 30 and 42 psi are marked on the pressure gauge.
2. Pressure set below 18 psi will not overcome the DCV (drip control valve) in the nozzle assembly and therefore will not spray.

2. On an area of ground away from the pitch area, briefly switch on the pump. Observe the pressure gauge. Adjust the pressure with use of the valve. Observe the spray pattern. Check that the spray fan just reaches the line forming disks at the top of the grass height. For hard surfaces the spray fan should just reach the line forming disk at the ground surface. If necessary adjust the nozzle height. Turn off the pump.

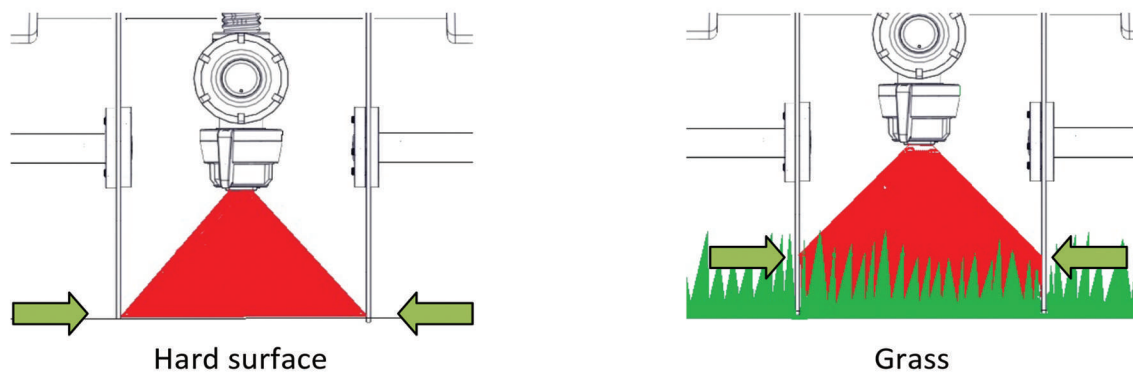

Fig 15 Illustration showing fan patterns

3. Slide the small gate up at the bottom of the bonnet. Close the bonnet. Ensure the paint and water pipes are seated below the telescopic nozzle arm and the bonnet is held in the closed position with the magnets. This ensures the nozzle arm is held securely.
4. The Ki is now ready for line marking.

Note: If at switch on, the paint spray pulsates and the needle in the pressure gauge flickers violently, this could indicate that there is an air lock in the paint delivery hoses (it is normal for the pressure gauge needle to flicker a small amount). To resolve an air lock, refer to the trouble shooting guide at the back of this document.

Marking a line with Ki

Switch the pump on and immediately start walking at a steady and constant speed along the guide line. The guide line could be a previously marked line, string or chalk line. At the end of the line, stop walking and switch the pump off. Lift the line forming disks from the surface and position the machine at the start of the next line. If there is to be a short break in marking, always flush the nozzle with water using the nozzle flush system. To use the nozzle flush system, refer to the following section.

FLUSHING THE NOZZLE

The nozzle may be flushed without the need to flush the complete system.

General flushing

Before a pause in line marking, for example a coffee break, flush the nozzle using the outer plunger. Lift the plunger about 50 mm (2 inches) and with the palm of the hand, firmly push the plunger down.

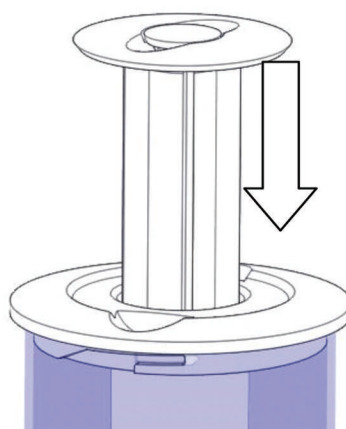

Fig 16 Flushing using the outer plunger

Blockage clearing

If the nozzle is blocked or if the spray fan pattern is irregular, use the inner plunger. Lift the inner plunger about 50 mm (2 inches) and push the plunger down. Ensure the outer plunger is pushed fully down.

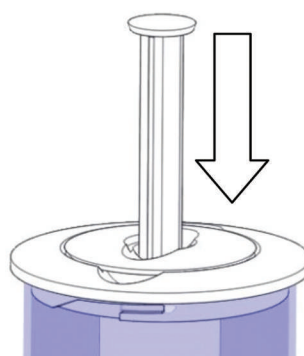

Fig 17 Flushing using the inner plunger

Note: To allow the inner plunger to fill, raise the outer plunger very slightly.

END OF DAY FLUSHING AND CLEANING

1. Position the Ki where the contents of the pipework can be flushed and cleaned.
2. Remove the paint bag. If there is paint in the bag which will be used later, wipe around the paint bag nozzle with a 'Fleet wipe'.
3. Wipe around the paint delivery connector with a 'Fleet wipe'.
4. Fill the bottle with water. Screw the bottle onto the lid. This ensures the paint connector stays moist and functional.

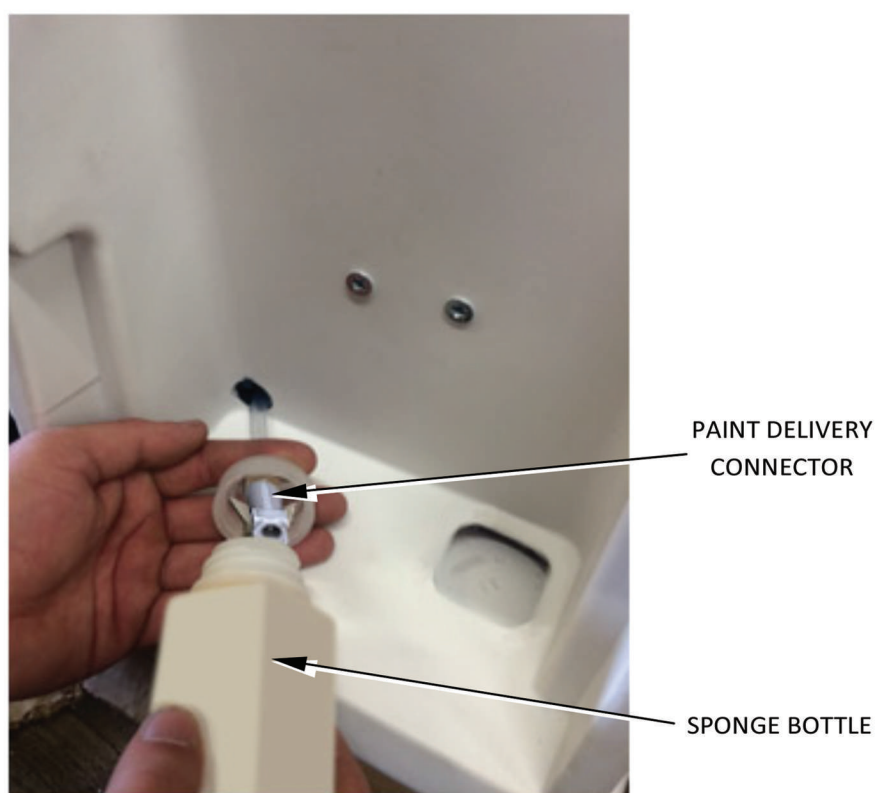

Fig 18 Fitting the connector into the bottle

5. Use the general flushing procedure using the outer plunger. Flush the nozzle three or four times using this procedure.
6. Remove the bayonet cap complete with the nozzle tip and filter. If necessary, carefully brush any paint deposits from the filter mesh.

Full System Flush

1. Connect the hose adaptor to the paint delivery connector at the rear of the Ki.

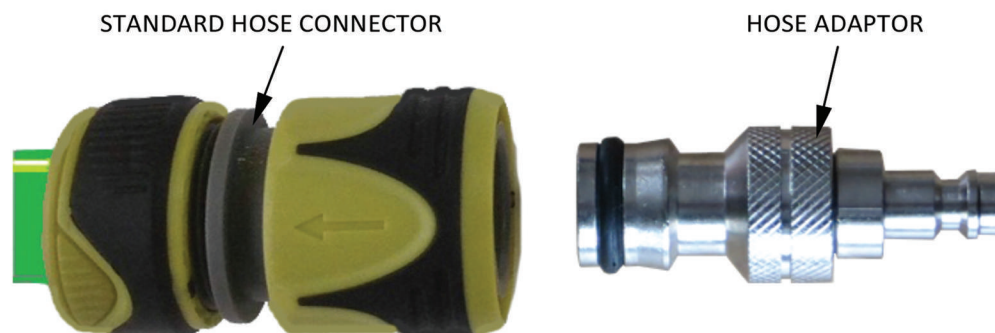

Fig 19 Hose connector and hose adaptor

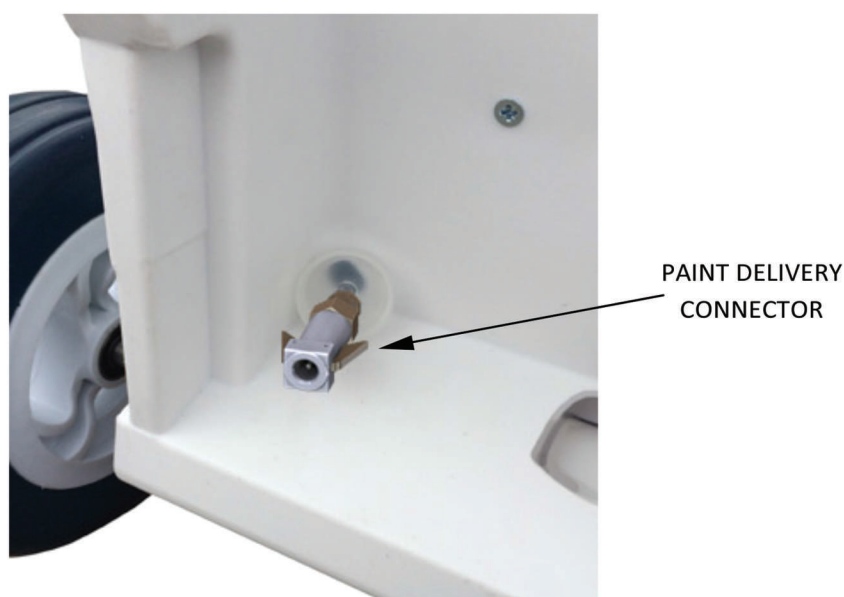

Fig 20 Paint delivery connector

2. Fit a standard garden hose connector to the adaptor.
3. Ensure that the bayonet cap, complete with the nozzle tip and filter are removed from the nozzle assembly.
4. Turn on the water supply on slowly to avoid a sudden pressure surge. Allow the water to flow through the system. Fully open the pressure relief valve to allow water to flow around the bypass circuit.
5. When no discolouration of the water leaving the nozzle can be seen, turn off the water and disconnect the hose and adaptor.
6. Replace the bayonet cap complete with the nozzle tip and filter into the nozzle body.
7. Using a Fleet wipe, wipe any paint overspray from the following:
 - a. Line forming disks and guide shafts. Build up of paint on the guide shafts will make line width adjustment more difficult.
 - b. Threaded nozzle adjustment post.
8. Generally clean and remove paint overspray or spills from the Ki.

Ultra sonic cleaning

The Fleet Ultra Sonic Bath, available as an addition to the Ki system, is used for thoroughly cleaning small parts which cannot be cleaned effectively using normal methods. The sonic bath is primarily used for the nozzle tip. It is important that the nozzle tip is kept scrupulously clean to provide a well defined line. Other small parts can also be cleaned in the sonic bath such as, nozzle filter and nozzle washer.



Fig 21 Sonic bath

STOWING THE KI

When the Ki has been flushed and cleaned, prepare the Ki for transport or storage as follows:

1. Using the spring clips, park the line guide disks in the recesses in the side of the body.
2. Open the bonnet.
3. Lift the telescopic nozzle arm and release the paint and water pipes from the notch in the front of the body.
4. Squeeze the arms of the spring collar together and raise the nozzle to the maximum height.
5. Tilt the nozzle post to the horizontal position and push the nozzle assembly into the body cavity collapsing the telescopic arm.
6. Tuck the hose loops at the back of the nozzle assembly in between the manifold and the pump shown below.



Fig 22 Nozzle assembly stowed

7. Carefully arrange the water and paint hoses in the body cavity.
8. Close the bonnet and slide the small gate closed.
9. Unclip the rear cover from the handle supports. Pivot the rear cover and rest it on the bonnet.
10. Depress rectangular buttons on the handle bar cross member and lower handles fully.
11. Depress round buttons and rotate handle grips until both grips face inward.
12. Flip the rear cover over handles and locate it on the rear of the body.
13. The Ki is now ready for transportation and/or storage.



Fig 23 Ki ready for transport

TROUBLE SHOOTING

If the Ki is not producing the perfect line, the table below is to help diagnose and remedy simple issues. The main cause for failure is inadequate cleaning/flushing. It is imperative to keep the paint system free from dried paint particles.

No.	Issue	Cause	Remedy
1	Intermittent line/Pressure gauge flickering violently	Airlock in paint system	Bleed paint system as follows:- Away from the pitch area or have a small container ready to collect paint. Disconnect the paint tube from the back of the nozzle assembly (paint tube is on the left hand side when looking on the front of the machine). To release quick connections refer to the 'Quick connectors' section below. Switch the pump ON and allow paint to flow from the tube for 5-10 seconds. Open and close the valve on the manifold a few times to purge the bypass system. Turn the pump off. Replace the tube into the nozzle connector.
2	Line striping	1. Nozzle tip contaminated 2. Insufficient pressure	a. Flush nozzle with the outer plunger of the nozzle flushing system. Observe the spray pattern. If the spray fan is uneven or weak use the inner plunger to clear any blockages. (See 'Flushing the nozzle') b. Remove nozzle and clean in Sonic bath. c. Replace with new nozzle. Increase pressure using bypass valve on manifold.
3	Low pump pressure	Low battery charge	Use battery monitor to check battery status. Recharge battery.

MAINTENANCE ACCESSORIES

These accessories are available from the Fleet Line Markers online store. Visit <http://www.flmuk.com/store/category/general>

Fleet wipes - A tub of beaded hand/machine wipes which help keep your machine free of paint and grime and to keep the Ki operating smoothly.

Fleet Ultrasonic cleaner - For thorough cleaning of nozzles and couplings.

Quick connectors

Removal

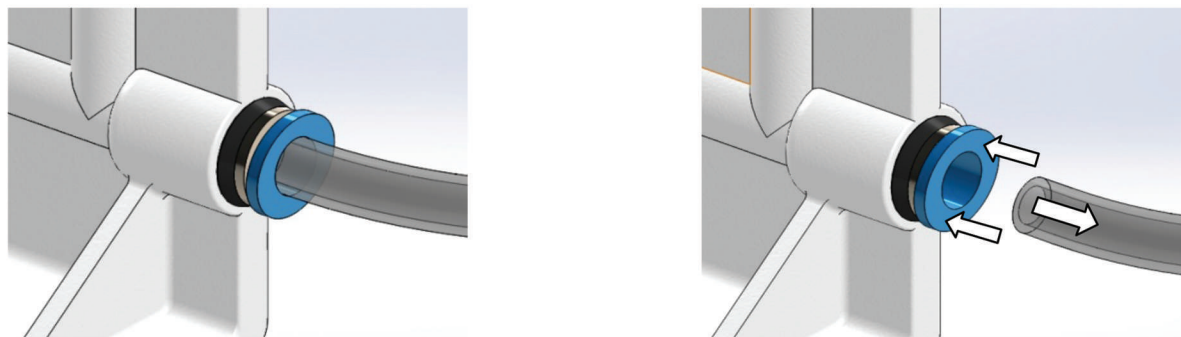

Fig 24 Quick connector

1. To release a hose from a quick connector, push evenly on both sides of the blue collar.
2. With the collar pushed in, pull the hose from the connector.

Replacement

1. Check the end of the hose, ensure that it is cut square and that there are no defects or abrasions that might prevent a good seal.
2. To replace a hose into a quick connector, simply push in the pipe. The hose should be inserted 15 mm to ensure a good connection.

Note: The quick connectors in the manifold and the nozzle are adhered in place and cannot be removed. In the event a quick connector failing in either of these parts, the whole assembly has to be replaced.

Note: Avoid sharp bends close to a quick connector as this may cause a leak.

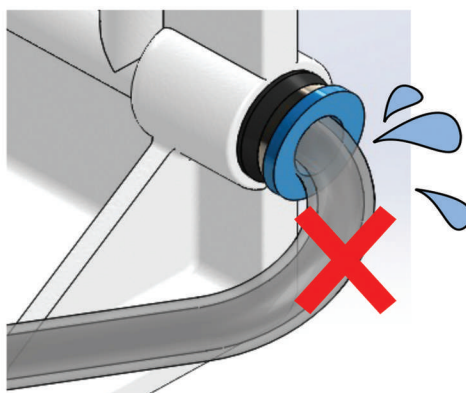

Fig 25 Avoid sharp bends



Fleet recommends the following products to keep your Ki looking like new.

www.fleetaustralasia.com.au

Turfmate Limited 39 Winterton Rd, Clayton VIC 3168. Australia

Tel: 1300 184 400 Fax: 954 00909