



G821-C

Parts Diagram

2014 - 2018 Chevy 1500

With 5.3L Engine

Max : Wheelbase

Item	QTY	Part NO.	Descriptions	
1	1	MPI - 20	Right Side Tail Pipe	
2	1	MPI - 24	Left Side Tail Pipe	
3	1	MPI - 22	Left Side Axle Pipe	
4	2	MPI - 0 - 60	Head Pipes	
5	1	MPI - PC14	Pulse Chamber	-
6	1	Reuse Factory	Ball Clamp	-
7	5	MPI - SC225	2 1/4" Clamp - std.	-
8	2	MPI - BCSS225	2 1/4" Band Clamp	-
9	1	Hanger - 40	Right Hand Muffler	▶
10	1	Hanger - 42	Right Tail Pipe	◆
11	1	Hanger - 43	Left Tail Pipe	▲
12	1	Hanger - 41	Left Hand Muffler	●
13	1	Hanger - 39	Head Pipe	■
14	2	-	Mufflers	14"
15	2	2435	Tips	12"
16	2	MPI-Wire tie	Wire tie	9"
17	1	MPI - 3/8-1.5	Bolt - H02	1 1/2"
18	1	MPI-HD-003	Rubber Block	▲ #20

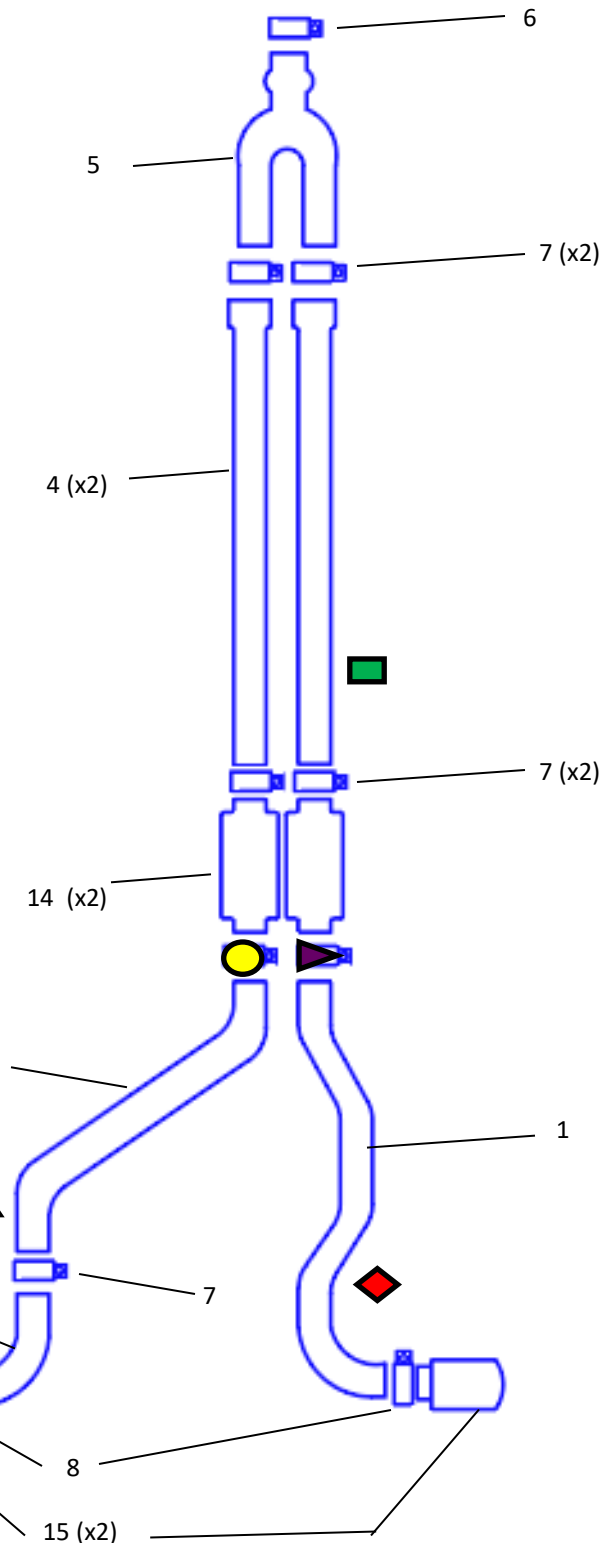

Muffler Offset Diagram





G822-C

Parts Diagram

2014 - 2018 Chevy 1500

With 5.3L Engine

Max : Wheelbase

Item	QTY	Part NO.	Descriptions	
1	1	MPI - 21	Right Side Tail Pipe	
2	1	MPI - 23	Left Side Tail Pipe	
3	1	MPI - 22	Left Side Axle Pipe	
4	2	MPI - 0 - 60	Head Pipes	
5	1	MPI - PC14	Pulse Chamber	-
6	1	Reuse Factory	Ball Clamp	-
7	5	MPI - SC225	2 1/4" Clamp - std.	-
8	2	MPI - BCSS225	2 1/4" Band Clamp	-
9	1	Hanger - 40	Right Hand Muffler	▶
10	1	Hanger - 42	Right Tail Pipe	◆
11	1	Hanger - 43	Left Tail Pipe	▲
12	1	Hanger - 41	Left Hand Muffler	●
13	1	Hanger - 39	Head Pipe	■
14	2	-	Mufflers	14"
15	2	2435	Tips	12"
16	2	MPI-Wire tie	Wire tie	9"
17	1	MPI - 3/8-1.5	Bolt - H02	1 1/2"
18	1	MPI-HD-003	Rubber Block—LR	▲ #20

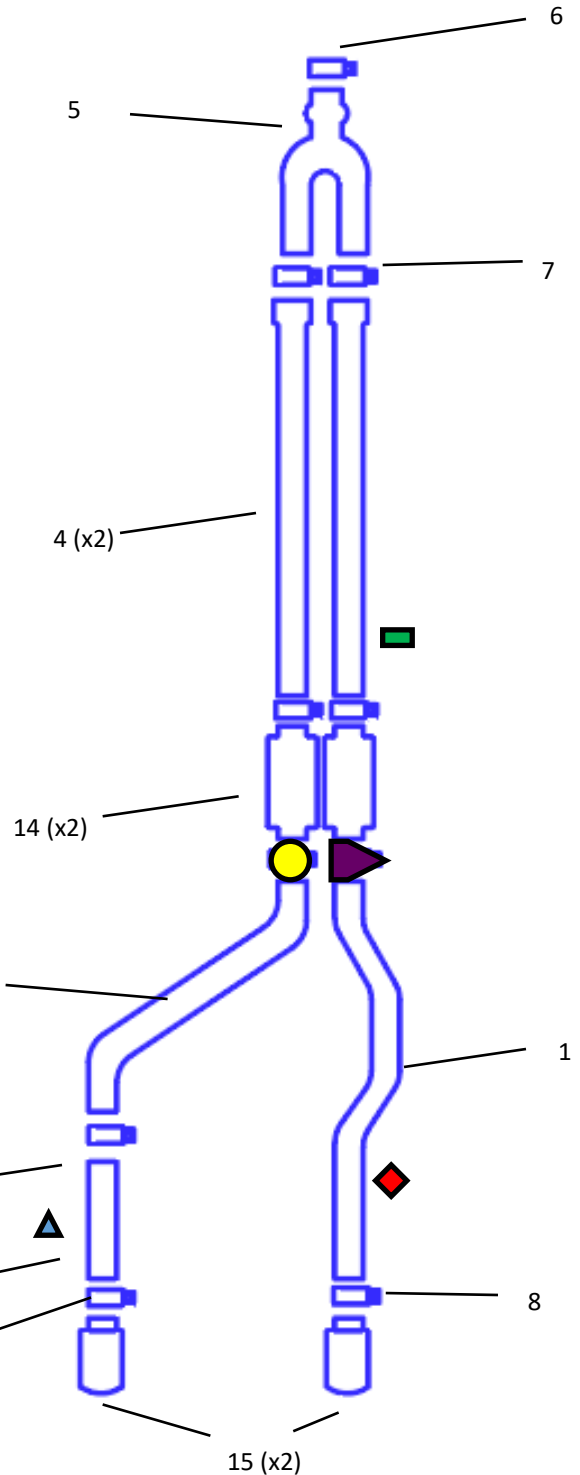

Muffler Offset Diagram



Customer Support And Warranty information



Thank you for purchasing a MPI Exhaust Technologies System and letting MPI Exhaust customize your ride today! We have a friendly and knowledge staff so contact us with any questions. Enjoy the Sound of Perfection

Questions -

ONLY contact MPI Exhaust Technologies if any products are possibly missing, damaged, during shipping or if you have any question about the products.

Call @ 406-669-3286

Installation -

Watch the tutorial YouTube videos before installation or calling @mpi exhaust, we have a very knowledgeable staff that has installed hundreds of these kits.

Warranty -

Contact

Phone - (406) 669-3286

Email : mikespipesinc@gmail.com



G821 & G822

Installations

2014 - 2018 Chevy 1500

With 5.3L Engine

Max : Wheelbase

1. Unbolt factory 13mm Clamp Behind 3rd converter and remove factory systems after that connection. Leave factory rubber hanger mounts on chassis mounts.
2. Using Anti-seize, apply to connections surface on both PC-14 and stock system.
3. Reusing factory clamp install PC-14, ensure level and straight with chassis for best clamping force.
4. Install head pipe hanger without saddle to help hold / offset head pipe location
5. Slide head pipes over pulse chamber, using clamp MPI-SC225. Cut Head pipe to wheel-base length. View diagram for measurement. Duplicate length for both head pipes.
6. When installing muffler pack, ensure offset is towards the engine with the offset downwards, install rear hanger in rubber grommets to hold rear of mufflers. View diagram for hanger Part Numbers.
7. Tighten all clamps to this point except for rear mufflers hangers. Move clamps to the connection edge for best clamping force,
8. Locate and install Right tail pipe hanger without saddle, slide Right Tail into muffler 2"
9. Install hanger saddle and tips to verify tail pipe height before clamping
10. Predrill hole for LR hanger, drill hole on the frame same distance the RR hanger is welded to frame. Then using self tapping bolt and rubber block. Install new mount on chassis. (leaving loose enough to swivel)
11. Install Axle and left hand tailpipe (using a stand to hold in location)
12. Install hanger saddle to help set height, adjust axle pipe to level tailpipe and tip exit height.
13. Ensure 3" of pipe inside your tips for best clamping force.
14. Once in final location tighten and wire tie brake lines together. Ensure proper clearance
15. Final tighten all clamps and clean tips.
16. Using brake clean, clean entire system

Extra info/tips*

Using black paint, coat the rubber block to match chassis

If matching tubing color paint is needed, rustoleum # 7715830 is close.

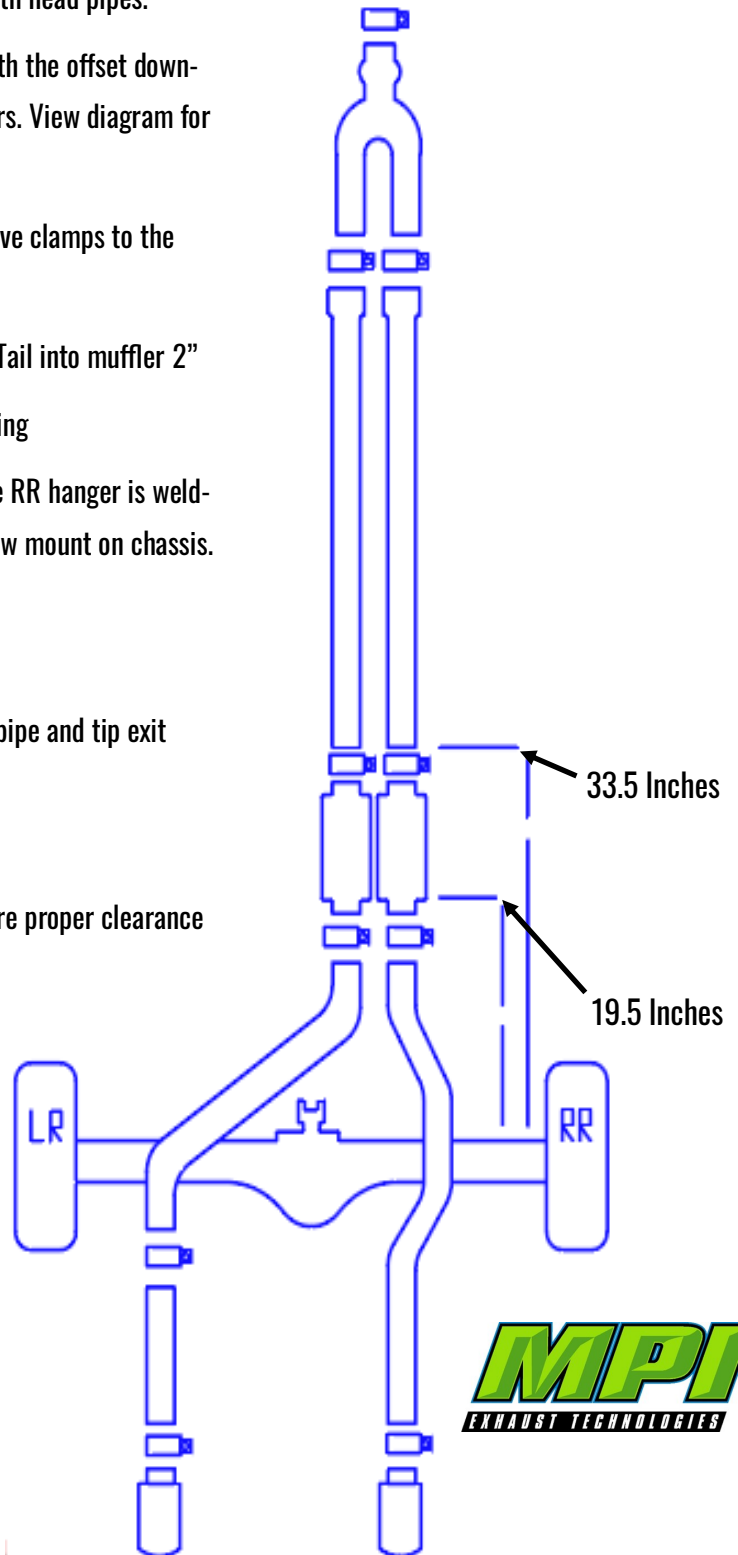

G8-12

G821-C & G822-C Instruction Packet

2014 - 2018 Chevy 1500

With 5.3L Engine

Max : Wheelbase



MPI
EXHAUST TECHNOLOGIES