







F251-C

Parts Diagram

2010 - 2016 Ford F250 - F350

With 6.2L Engine

Max : 176 - Inch Maximum Wheelbase

Item	QTY	Part NO.	Descriptions	Length
1	1	MPI - 14	Right Side Tail Pipe	70.5
2	1	MPI - 54	Left Side Tail Pipe	39
3	1	MPI - 53	Left Side Axle Pipe	47
4	2	MPI - 0 - 60	Head Pipes	60
5	1	MPI - PC12	Pulse Chamber	-
6	2	MPI - SC275	2 3/4" Clamp - std.	-
7	5	MPI - SC250	2 1/2" Clamp - std.	-
8	2	MPI - BCSS250	2 1/2" Band Clamp	-
9	2	MPI - SP204	4 Hole - 2" spacing	-
10	1	Hanger - 1	Right Hand Tail	
11	1	Hanger - 2	Head Pipe	
12	1	Hanger - 3	Right Hand Muffler	
13	1	Hanger - 4	Left Hand Muffler	
14	1	Hanger - 5	Left Tail Pipe	
15	2	-	Muffler	14"
16	2	2535	Tips	12"
17	2	MPI-Wire tie	Wire tie	9"
18	1	MPI - 3/8-1.5	Bolt - H02	1 1/2"

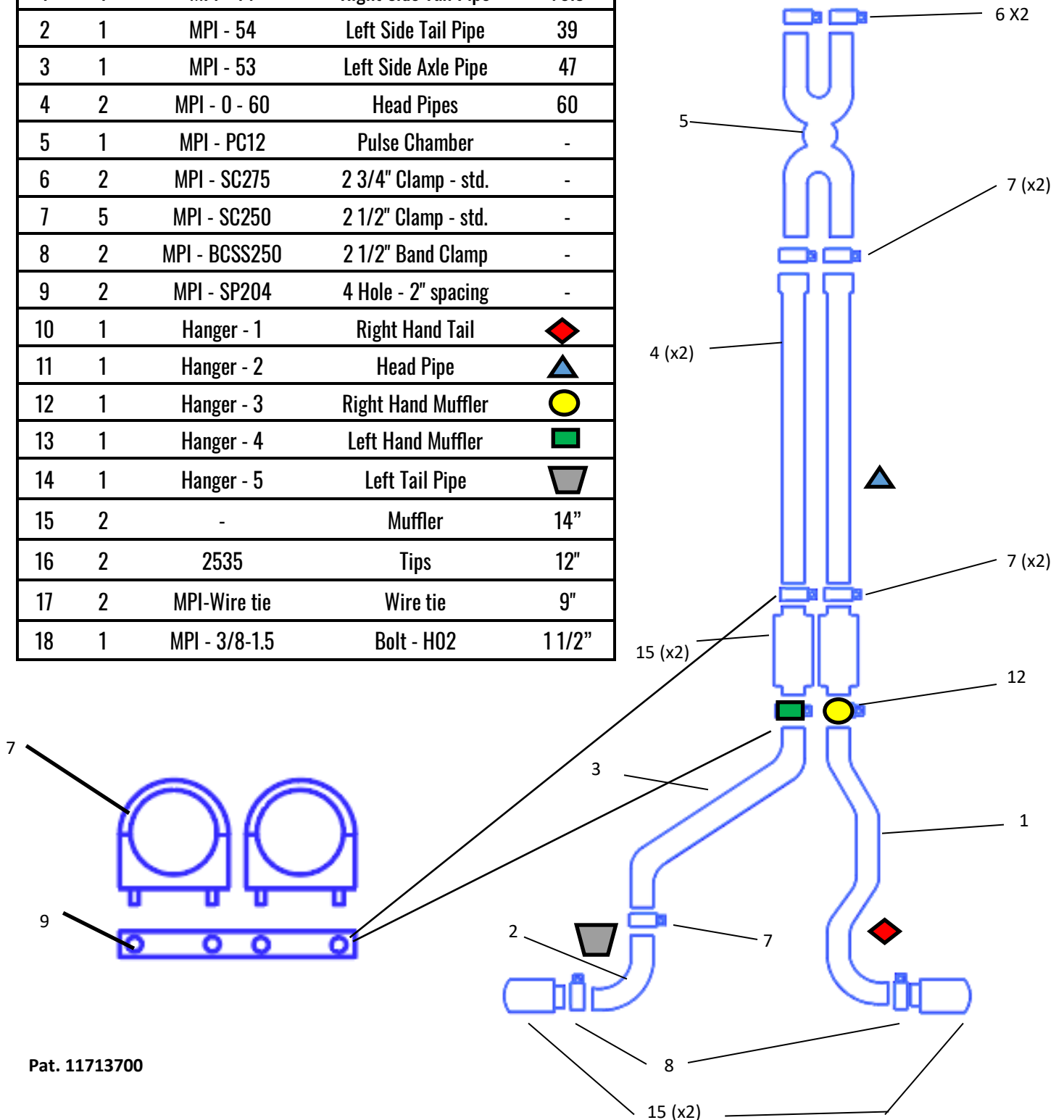







F252-C

Parts Diagram

2010 - 2016 Ford F250 - F350

With 6.2L Engine

Max : 176 - Inch Maximum Wheelbase

Item	QTY	Part NO.	Descriptions	Length
1	1	MPI - 14	Right Side Tail Pipe	70.5
2	1	MPI - 54	Left Side Tail Pipe	39
3	1	MPI - 53	Left Side Axle Pipe	47
4	2	MPI - 0 - 60	Head Pipes	60
5	1	MPI - PC12	Pulse Chamber	-
6	2	MPI - SC275	2 3/4" Clamp - std.	-
7	5	MPI - SC250	2 1/2" Clamp - std.	-
8	2	MPI - BCSS250	2 1/2" Band Clamp	-
9	2	MPI - SP204	4 Hole - 2" spacing	-
10	1	Hanger - 1	Right Hand Tail	
11	1	Hanger - 2	Head Pipe	
12	1	Hanger - 3	Right Hand Muffler	
13	1	Hanger - 4	Left Hand Muffler	
14	1	Hanger - 5	Left Tail Pipe	
15	2	-	Muffler	14"
16	2	2535	Tips	12"
17	2	MPI-Wire tie	Wire tie	9"
18	1	MPI - 3/8-1.5	Bolt - H02	1 1/2"

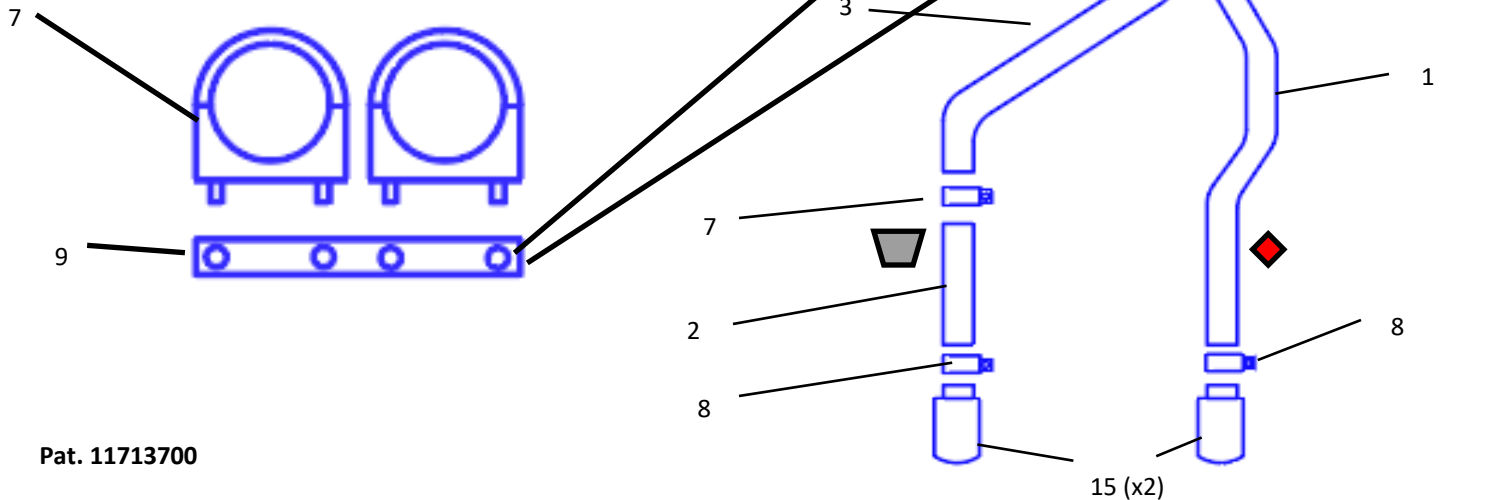

Customer Support And Warranty information



Thank you for purchasing a MPI Exhaust Technologies System and letting MPI Exhaust customize your ride today! We have a friendly and knowledgeable staff so contact us with any questions. Enjoy the Sound of Perfection

Questions -

ONLY contact MPI Exhaust Technologies if any products are possibly missing, damaged, during shipping or if you have any question about the products.

Call @ 406-669-3286

Installation -

Watch the tutorial YouTube videos before installation or calling @mpi exhaust, we have a very knowledgeable staff that has installed hundreds of these kits.

Warranty -



Contact

Phone - (406) 669-3286

Email : mikespipesinc@gmail.com





F 251-C - F252-C

Instructions

2010 - 2016 Ford F250 - F350

With 6.2L Engine

Max : 176 - Inch Maximum Wheelbase

1. Remove Factory tailpipe - Cut In front of dual in single out resonator as close to the case welds as possible on the inlet side
2. Slide Pulse chamber over Factory pipe then Clamp Pulse Chamber, offset away from driveshaft
3. Install the Right side Head Pipe, then trim to Wheelbase (view diagram) Snug Clamps as you go, don't final tighten yet
4. Install Right side muffler, Ensure Rear Muffler Measurement is correct to ensure proper tailpipe placement with Offset Toward Front
5. Repeat previous 2 steps for Left Side install (MPI - SP204) on Front with clamps,
6. Install Hanger Head Pipe Hanger—Final tighten all clamps to this Point
7. Install RR Tail Pipe Level, then clamp
8. Install RR hanger then install Tips check to ensure level and placement,
9. Use MPI-Wire tie to secure brake lines and Breather lines together
10. Install Axle Pipe & LR tail Pipe, Ensure proper Clearance for Spare tire and rear end Travel
11. Install LR hanger— Use bolt MPI - 3/8-1.5 to bolt through chassis
12. Install LR tip, Check level and positions to match RR
13. Install (MPI - SP204) on Rear Of Mufflers with clamps
14. Clean finger prints off tips with glass cleaner, clean pipes with brake clean, Paint Added Hanger Black on Chassis

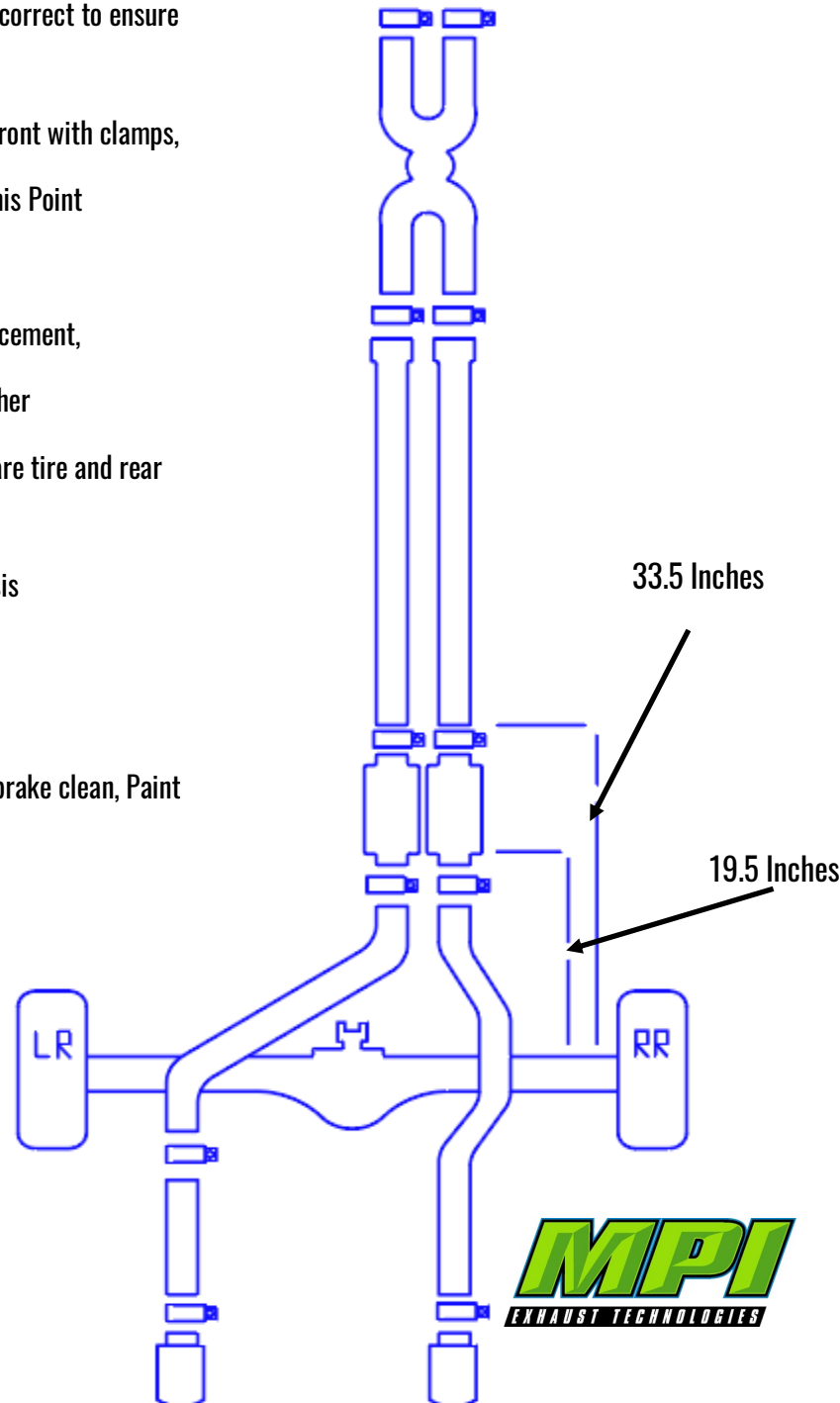

F 251-C - F252-C

Instructions Packet

2010 - 2016 Ford F250 - F350

With 6.2L Engine

Max : 176 - Inch Maximum Wheelbase

F2-12



MPI
EXHAUST TECHNOLOGIES