



Laser Diode LT-LD-525-1400M-C

LT-LD-525-1400M-C is a multimode laser diode with 1.4W CW output power at 525nm. It is supplied in a 9mm floating mounted TO can with Zener Diode. The laser diode is suitable for the use in various opto-electronic applications.

■ Absolute Maximum Ratings

Parameter	Symbol	Value	Unit
Forward Current (Tc=25°C)	I _f	2.3	A
Reverse Current (Tc=25°C)	I _r (LD)	85	mA
Storage Temperature	T _{stg}	-40~85	°C
Operating Case Temperature	T _c	0~65	°C

■ Initial Electrical/Optical Characteristics (Tc=25°C)

Parameter	Symbol	Condition	Min	Typ.	Max	Unit	
Optical Output Power	P _o	I _f = 1.9A	0.7	(1.4)	-	W	
Dominant Wavelength	λ _d	I _f = 1.9A	518	(525)	532	nm	
Threshold Current	I _{th}	CW	150	-	500	mA	
Slope Efficiency	η	CW	-	(0.8)	-	W/A	
Operating Voltage	V _{op}	I _f = 1.9A	4.0	-	5.5	V	
Beam Divergence*	Parallel	θ _{//}	I _f = 1.9A	0.2	(0.4)	0.6	°
	Perpendicular	θ _⊥	I _f = 1.9A	-1.0	(0)	1.0	°

() are reference figures.

* Full angle at 1/e² from peak intensity

■ Outline Dimension

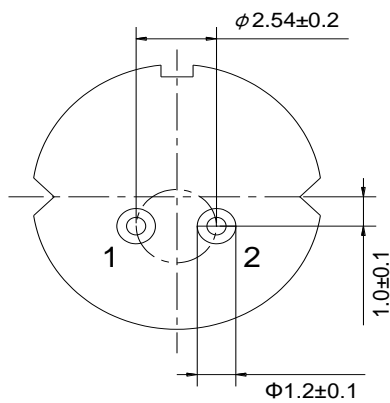
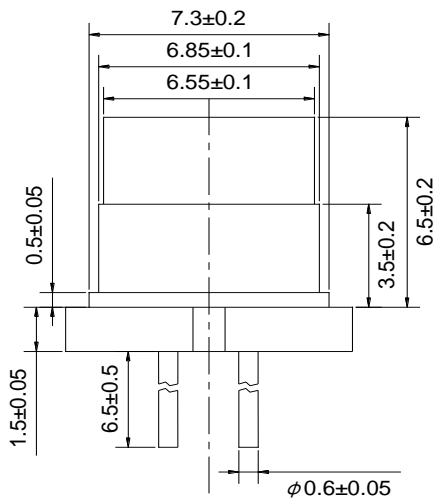
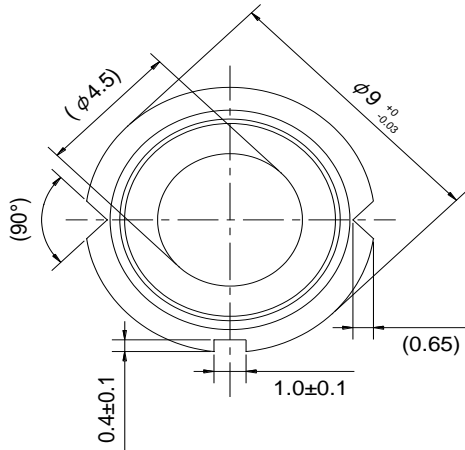

Connection

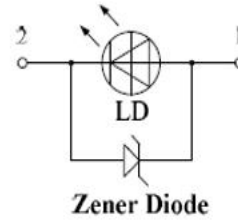

- 1. LD Anode
- 2. LD Cathode

Figures in () are reference purpose only.

Parts	Materials
Stem	Cu + Fe + Ni plating + Au plating
Lead	Ni-Fe-Co alloys + Ni plating + Au plating
Cap	Ni-Fe alloys + Ni plating
Glass	Borosilicate glass
Chip	Gallium nitride
Sub mount	Silicon carbide
Zener Diode	Silicon