



# LT-80W-AA PRO USER MANUAL

# CONTENT

---

## **1 LASER MODULE INTRODUCTION**

1.1 Parameters .....	1
1.2 Outline dimension .....	2
1.3 Standard configuration .....	3

## **2 LASER MODULE CONNECTION DESCRIPTION**

2.1 PIN Definition .....	4
2.2 Driver adapter .....	5
2.3 Connection .....	6

## **3 LASER MODULE REFERENCE SETTINGS**

3.1 For cutting .....	10
3.2 For engraving .....	11

## **4 PRECAUTIONS AND MAINTENANCE**

4.1 Precautions .....	12
4.2 Maintenance .....	12

# 1. LASER MODULE INTRODUCTION

## 1.1 Parameters

Optical power:	10W ( $\pm 1$ W)
Input:	<ul style="list-style-type: none"><li>• DC 12V 3A</li><li>• DC 24V 1.5A</li></ul>
Wavelength:	450nm ( $\pm 10$ nm)
Focus length:	45mm
PWM modulation:	0/3-12V, 0-5kHz
Fan speed:	10000rpm
Operating temperature:	0-60°C
Interface:	XH2.54-3P Socket
Cable:	3PIN, 80cm
Module size:	40*40*147mm
Module weight:	250g
Application:	Engraving or Cutting

## 1.2 Outline dimension (Unit: mm)

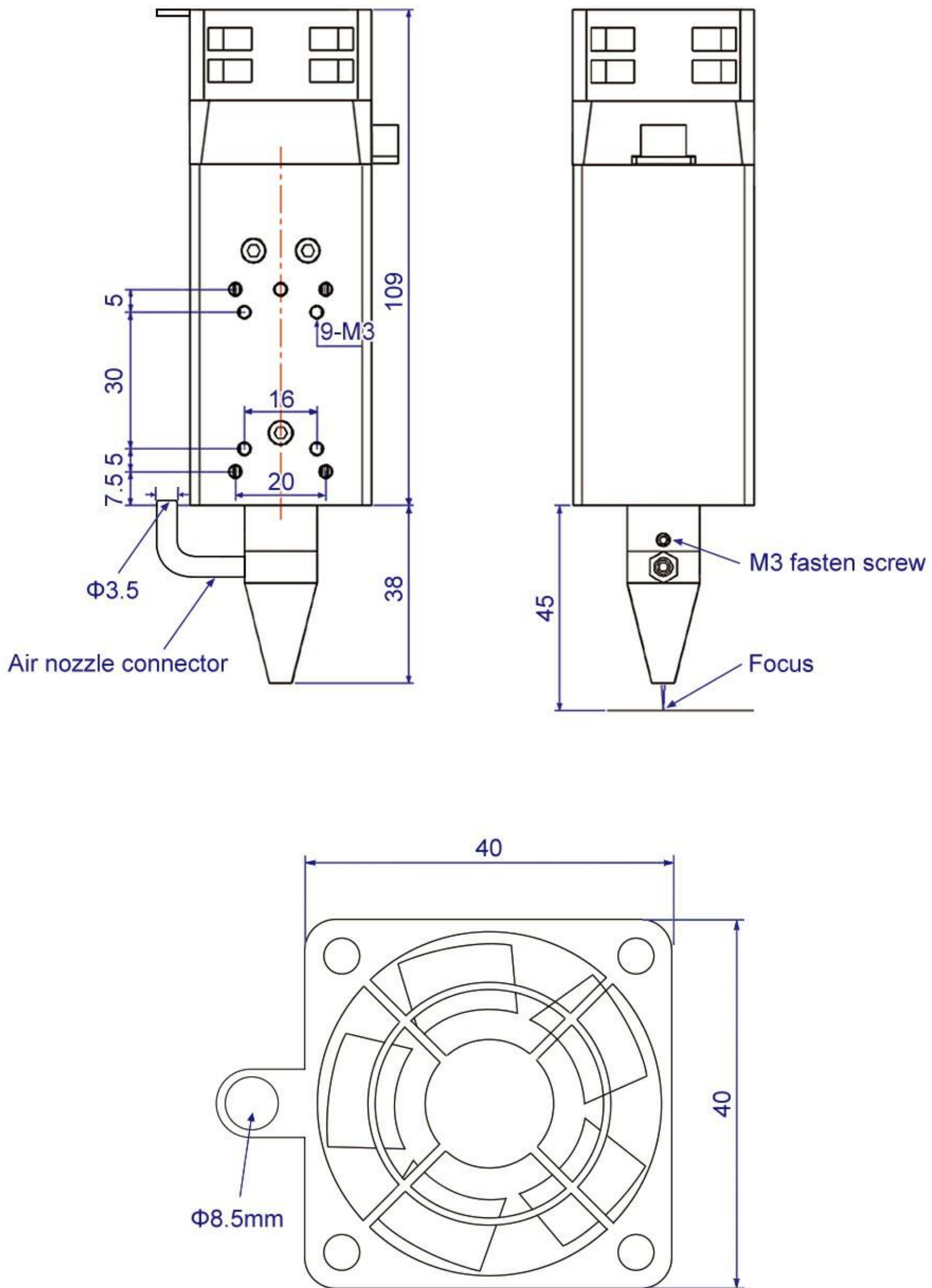

### 1.3 Standard configuration

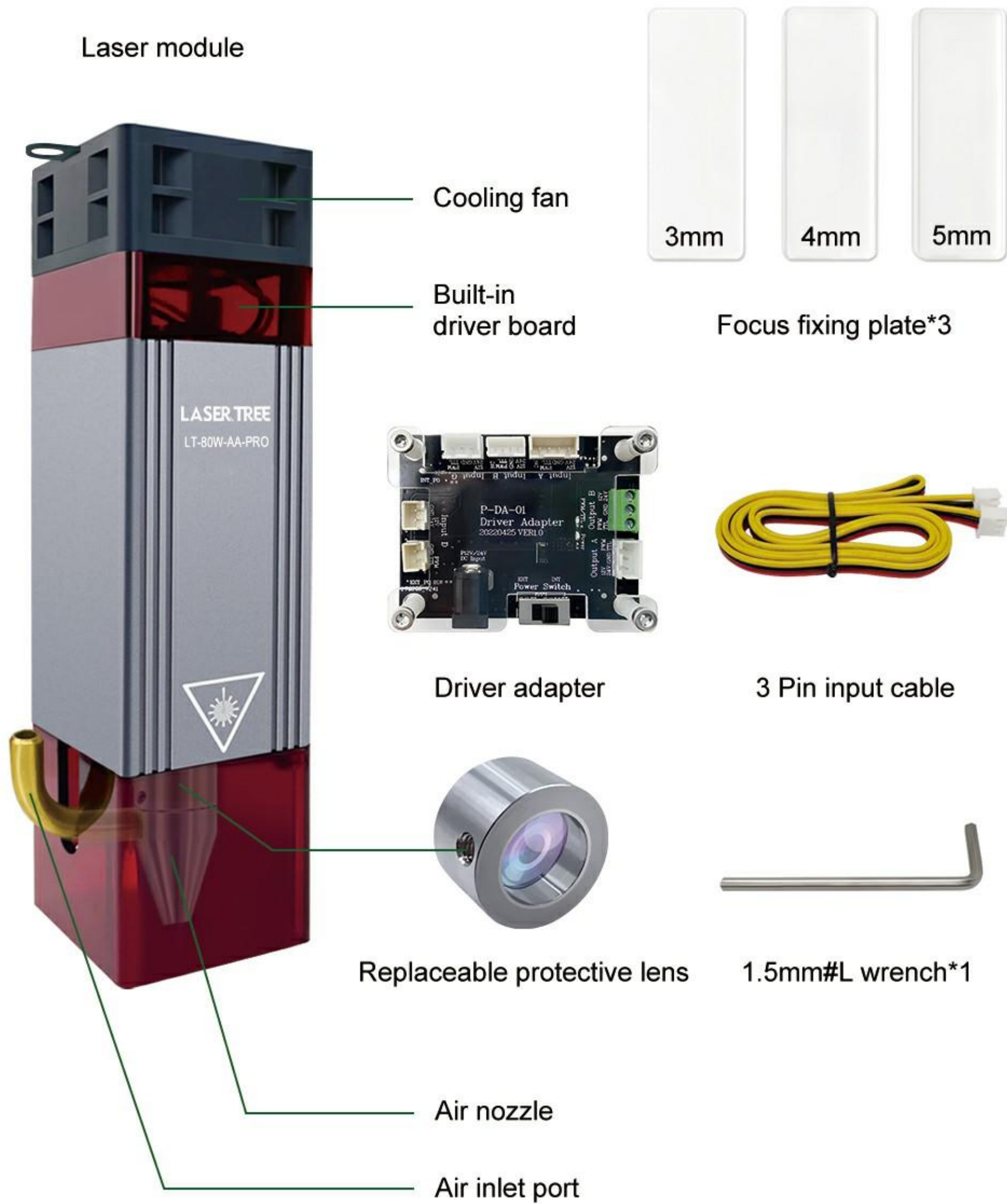

#### Air pump suggestion:

- Air pressure and capacity:  $\geq 0.027\text{kPa}$ , 27L/min

## 2. LASER MODULE CONNECTION DESCRIPTION

### 2.1 PIN Definition

 Built-in driver board

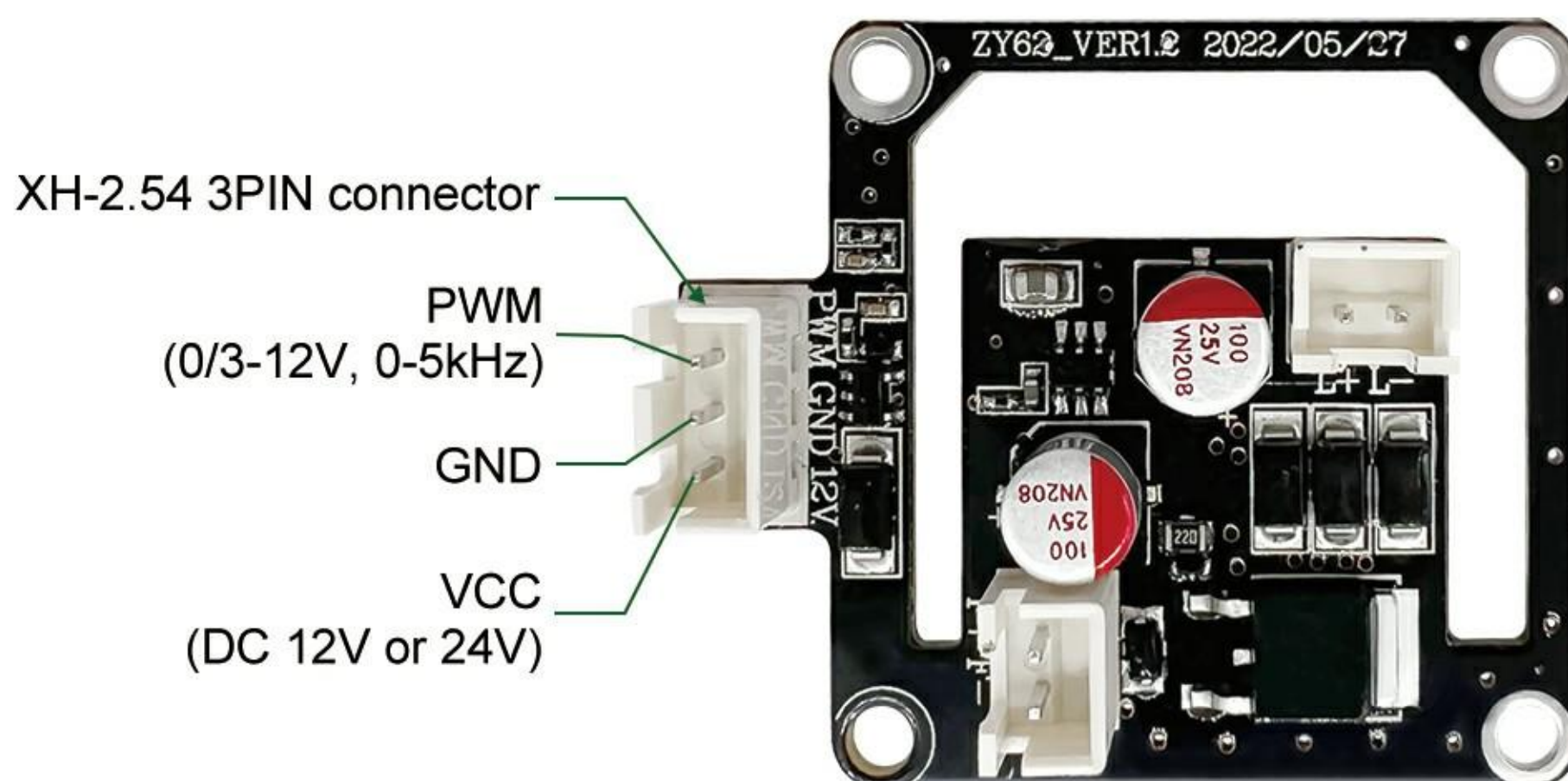

 Cable

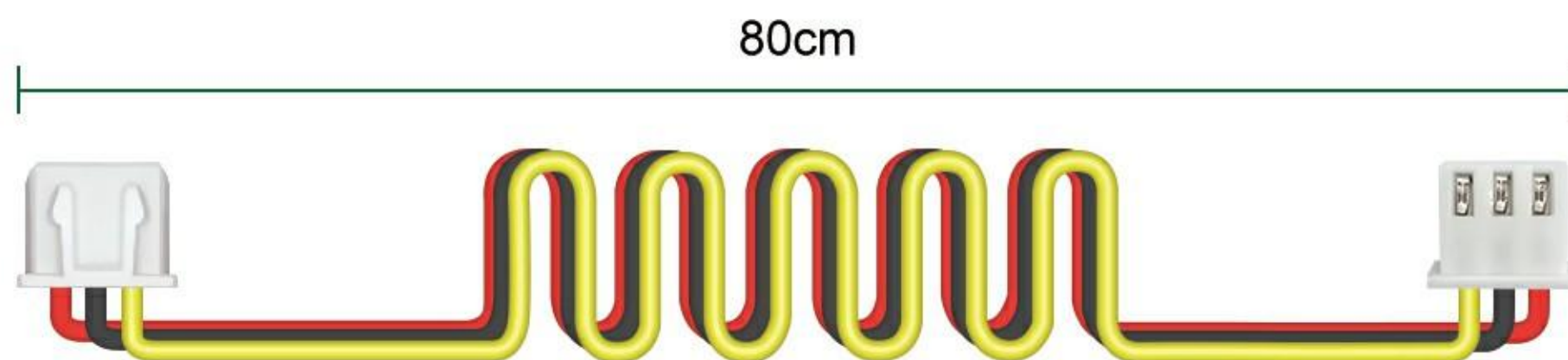

 Yellow wire: PWM

 Black wire: GND

 Red wire: Power (+12V/24V)

## 2.2 Driver adapter

Model: P-DA-01

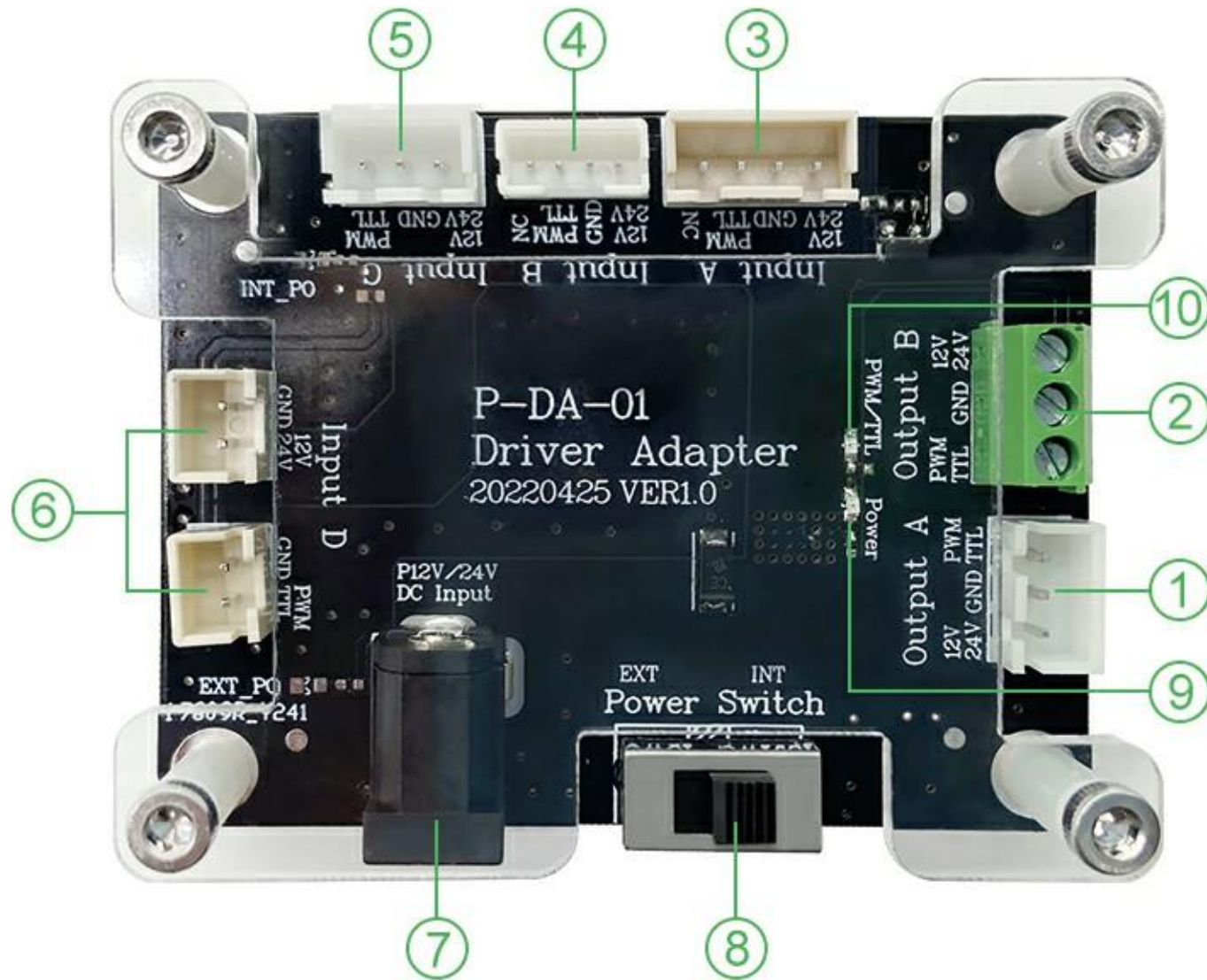

- ① Output A: 3PIN connector
- ② Output B: 3PIN connector
- ③ Input A: 4PIN connector
- ④ Input B: 4PIN connector
- ⑤ Input C: 3PIN connector
- ⑥ Input D: 2PIN connector
- ⑦ DC Input: 12V or 24V power adapter
- ⑧ Power Switch: EXT->External power supply  
INT->Internal power supply
- ⑨ Power indicator: It is red when the power cable is connected correctly.
- ⑩ TTL/PWM indicator: It is green when the TTL/PWM cable is connected correctly.

## 2.3 Connection

Please check whether the laser module is compatible with your engraving machine before connection.

### A. Check the voltage parameter of your engraving machine.

Please ensure that your engraving machine voltage and laser module are matched.

### B. Check the port of the main control board on your engraving machine.

Please find the PWM port, GND port and VCC port on the main board of your engraving machine. Then connect this laser module to the main board accordingly.

- “A”&“B”are both compatible.

Connect the laser module to the main board of your engraving machine directly.

Engraving machine main board

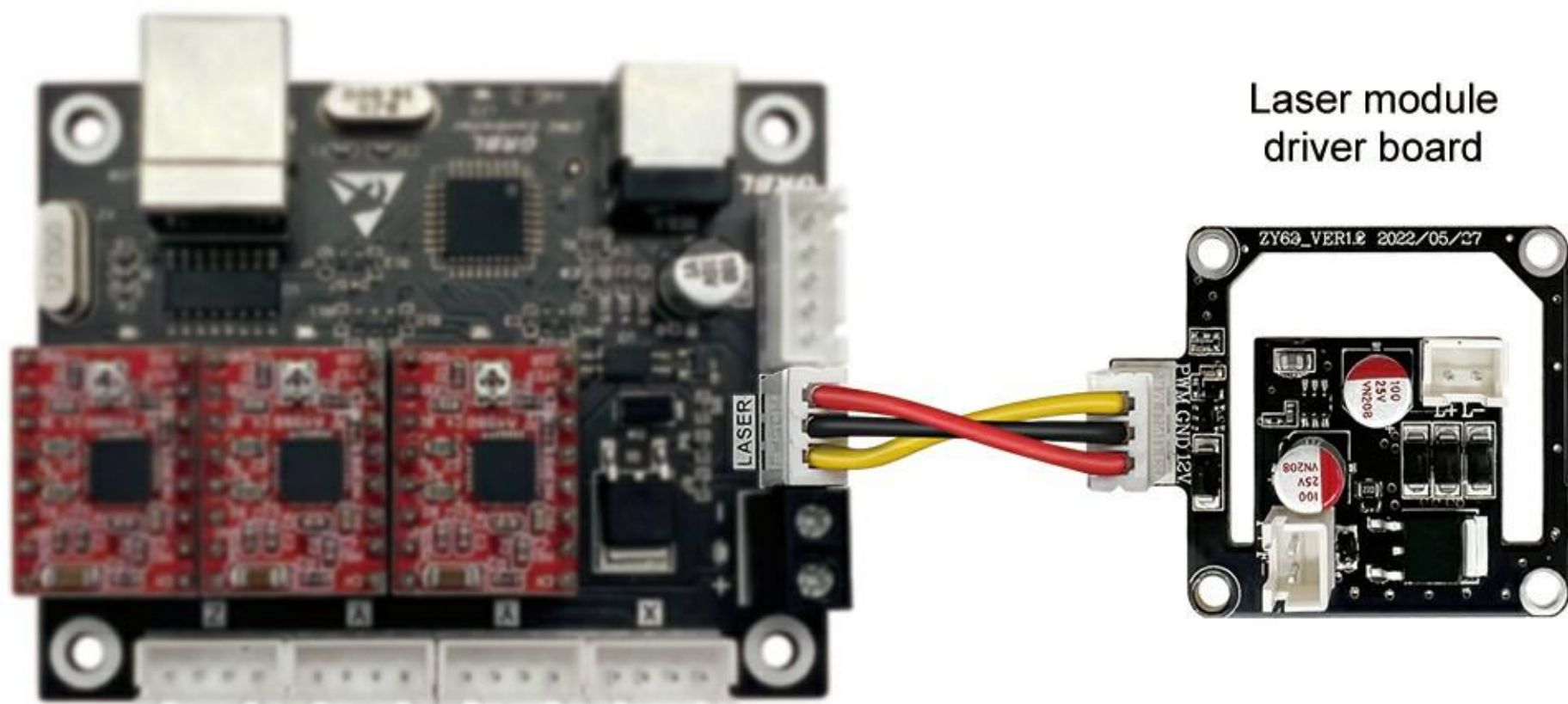

Reference picture



• Only voltage is not matched.

The voltage parameter of your machine are not matched to the module.

Machine	Laser Module	Solutions
12V	24V	Driver Adapter + 24V Power Supply
24V	12V	Driver Adapter + 12V Power Supply

- Step1** Connect the cable of your engraving machine to the corresponding input connector on P-DA-01.
- Step2** Connect the cable of the laser module to the Output A connector on P-DA-01.
- Step3** Connect the corresponding power adapter to the DC Input connector on P-DA-01. Push the switch to EXT position and the power is provided by external power adapter.

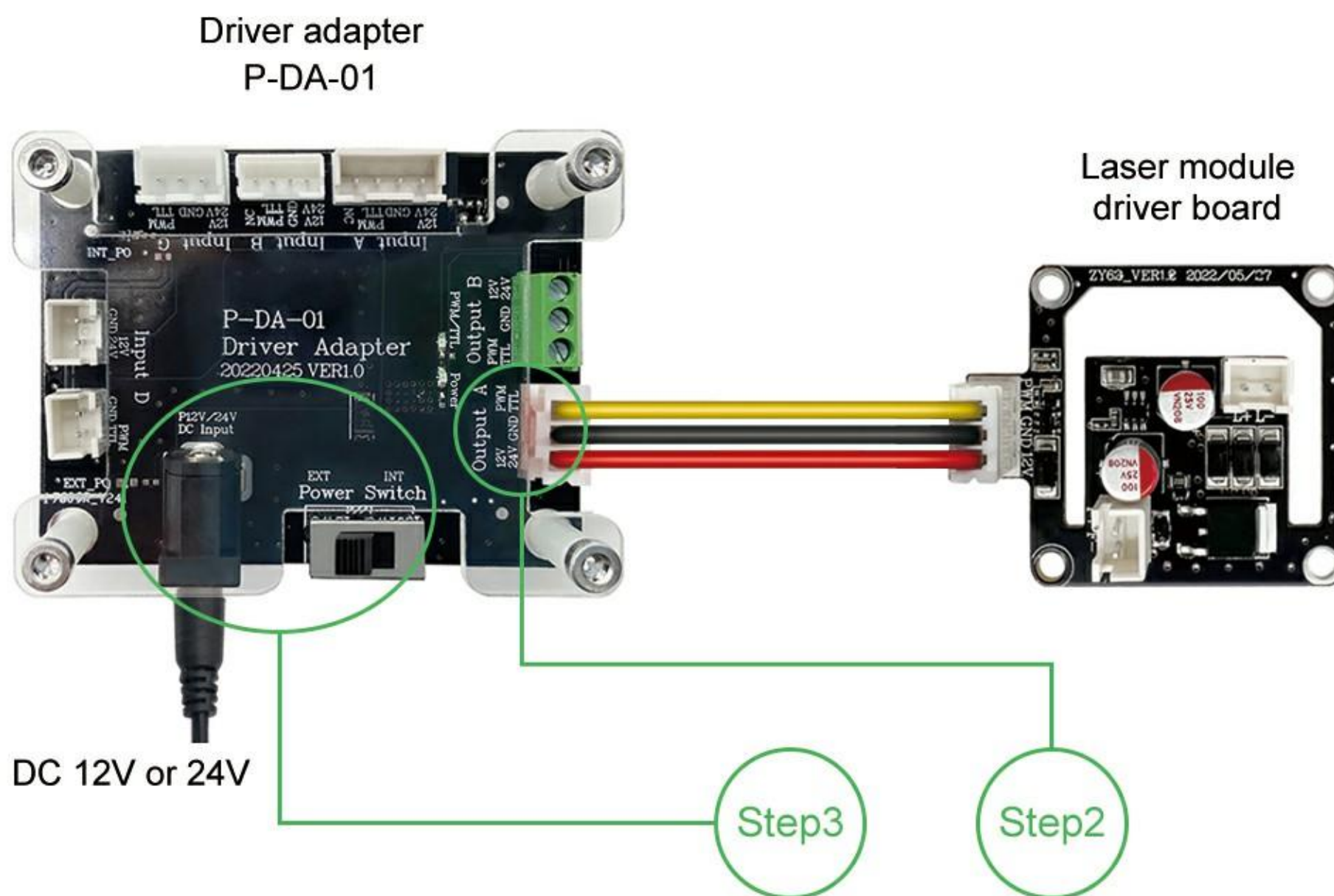

Reference picture

- Only control board pin definition is not matched.

Situation 1: The definition of connector on the engraving machine main board is not pin-to-pin.

Please rearrange the wire sequence of the cable to make each wire is well matched with the pin definition on the engraving machine main board.

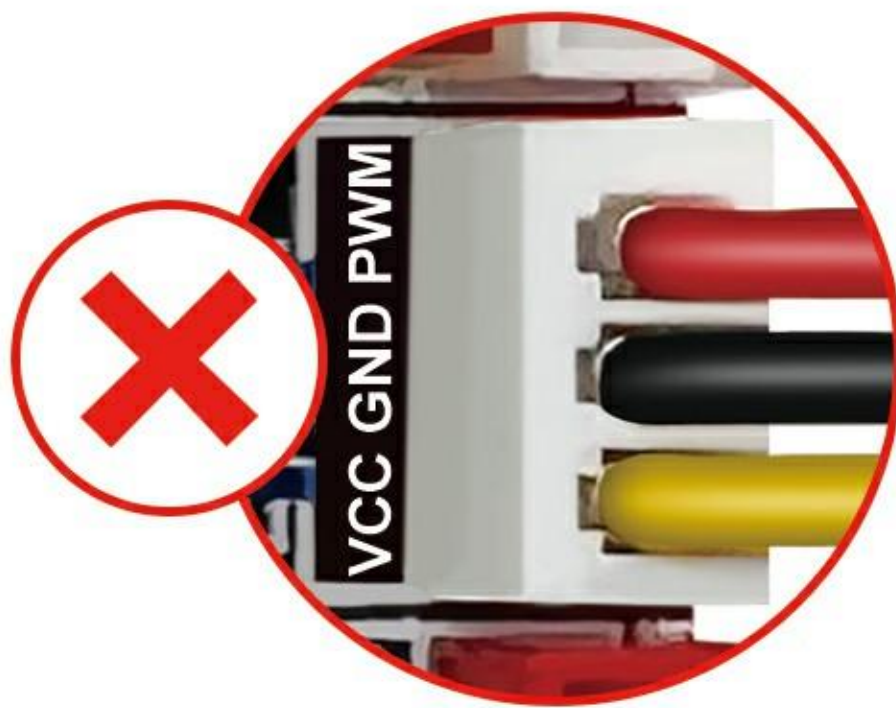

Red wire and yellow wire connection error



Red wire and yellow wire connection correctly

Situation 2: Please use P-DA-01 if the main board of your engraving machine is not 3pin, such as 2pin.

Laser Module	Machine	Solutions
3PIN	2PIN	Driver Adapter
	Other pins	Driver Adapter

- Step1 Connect the cable of the your engraving machine to the corresponding input connector on P-DA-01.
  
- Step2 Connect the cable of the laser module to the Output A connector on P-DA-01.

Engraving machine main board

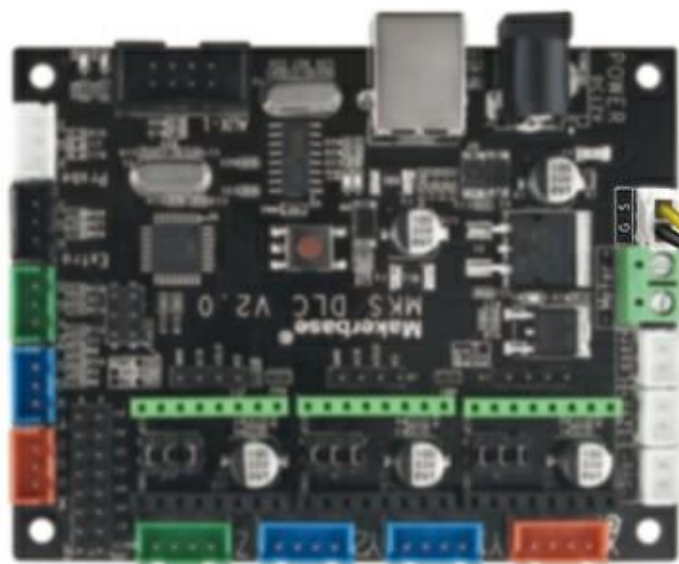

Driver adapter  
P-DA-01



Laser module  
driver board



DC 12V or 24V

Reference picture

### 3. LASER MODULE REFERENCE SETTINGS

#### 3.1 For cutting

The focal length of the LT-80W-AA-PRO laser module is 45mm.

 When cutting, you only need to make the focus located a bit lower than the surface of materials.

#### Reference settings for cutting

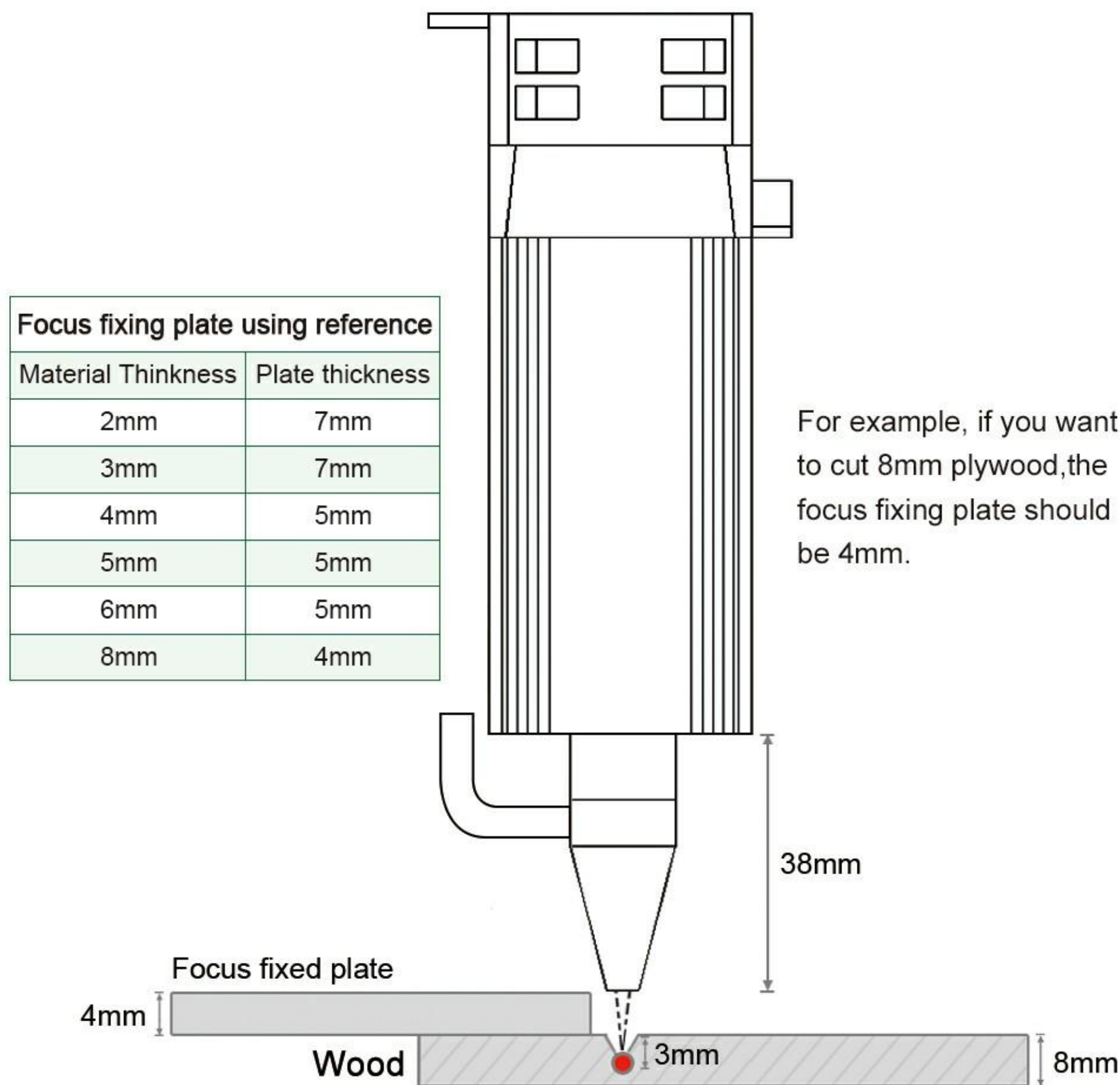

## 3.2 For engraving

 When engraving, please ensure that the focus is located on the material surface.

### Reference settings for engraving

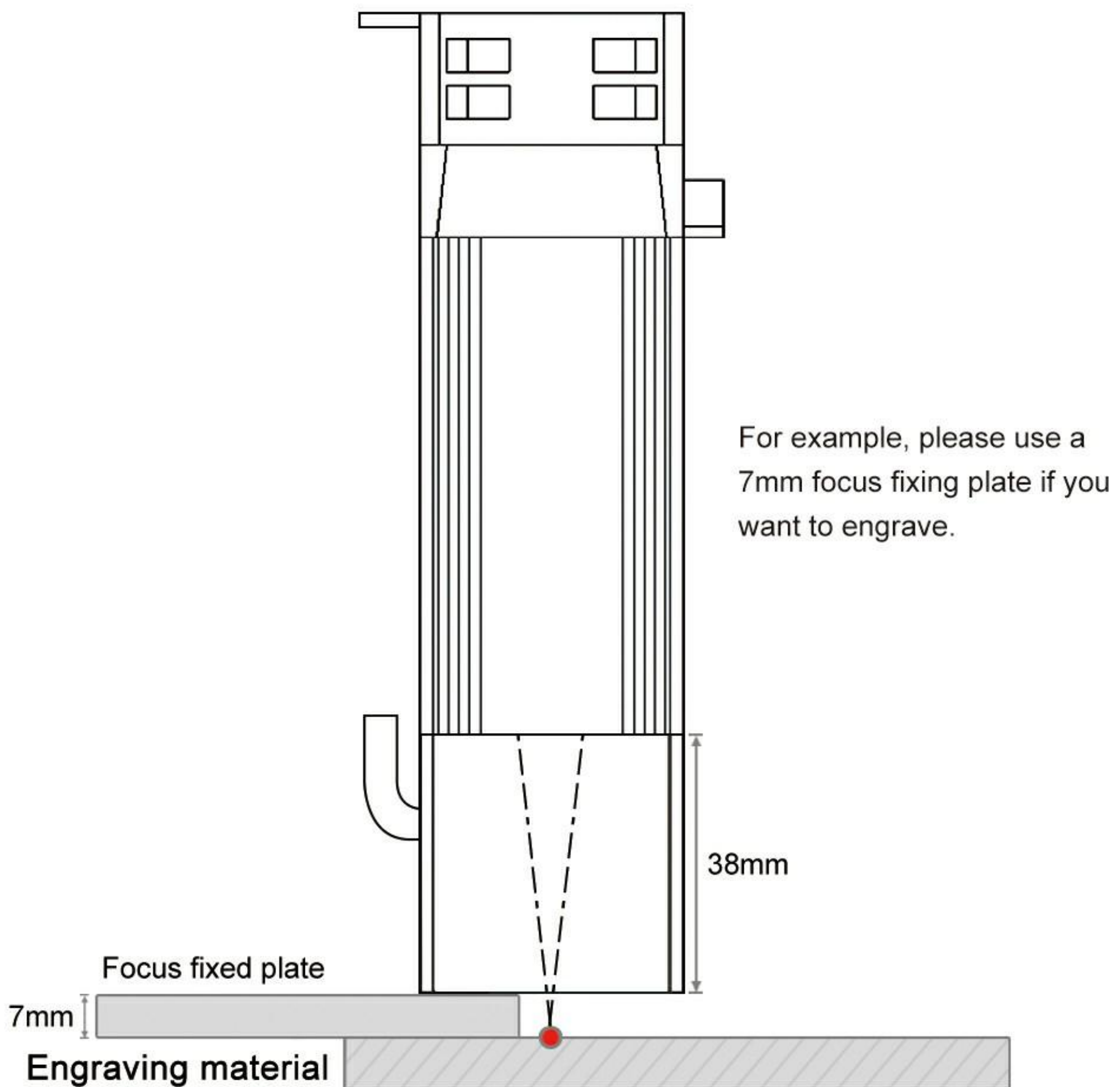

## 4. PRECAUTIONS AND MAINTENANCE

### 4.1 Precautions



Laser can damage a person's skin. Please do not expose your skin directly to the laser.



Please wear laser goggles to protect your eyes when you use this laser module.



Please ensure that the air pump is turned on before you start cutting. If not, the smoke will contaminate the lens.



This laser module doesn't support hot plug, hot plug may cause damage to the laser module.

### 4.2 Maintenance



When the laser module is not used for a long time, please ensure that the lens is not polluted by dust.



When you replace the air nozzle, please ensure that your operation will not pollute the lens. Finger prints or dust on the lens will weaken the output power of the laser module, or even damage the lens.



When you find the cutting ability decreases, the lens might be not clean. Please use a clean alcohol swab to clean it according to the following figure.

\* For more information about maintenance, please contact us at [lasertree@micost-optotech.com](mailto:lasertree@micost-optotech.com).

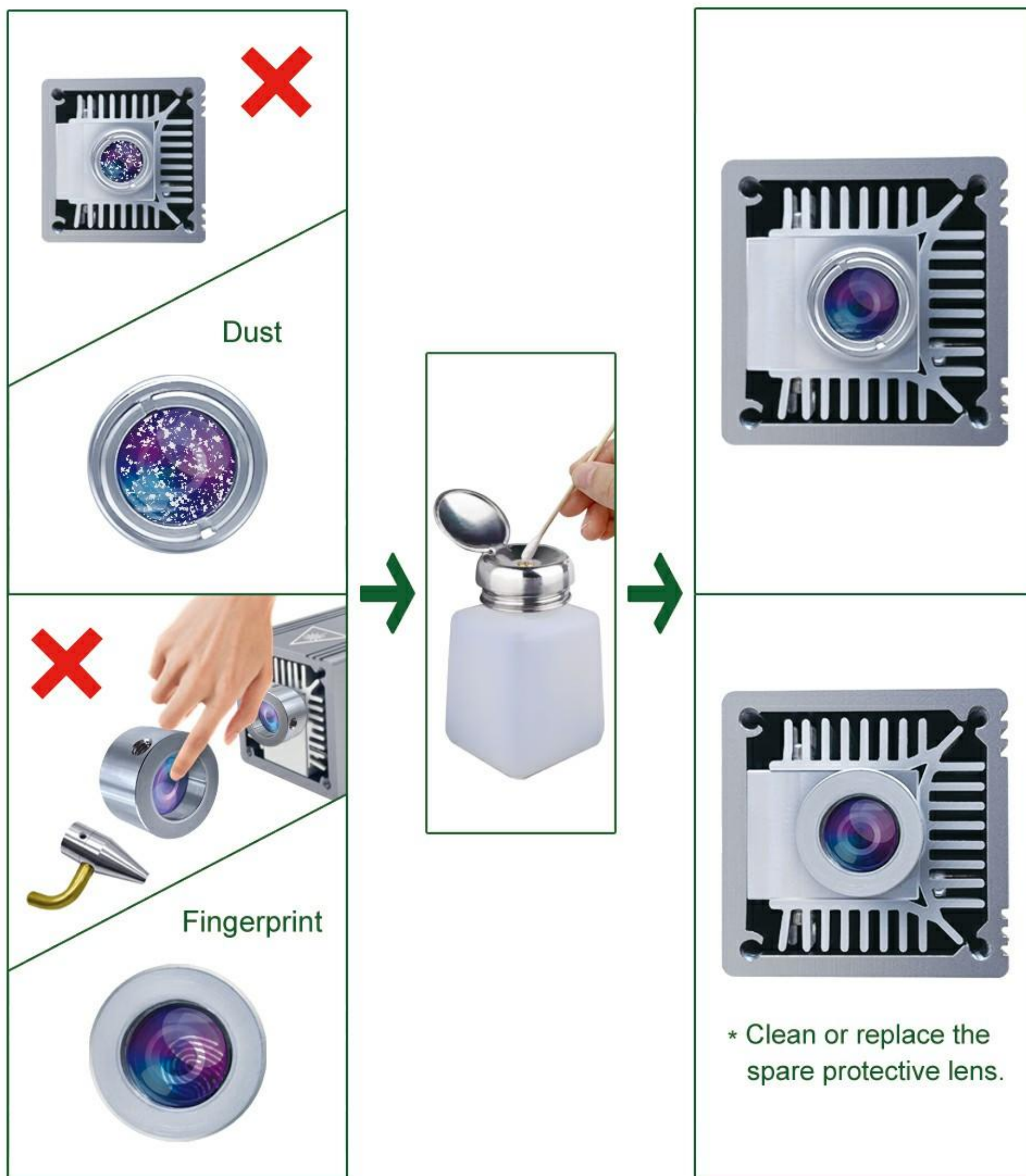



# LASER TREE

Enjoy pleasure of DIY