



K60

USER MANUAL

CONTENT

1. PRODUCT INTRODUCTION	1
1.1 Parameters	1
1.2 Outline dimension	2
1.3 Packing list	3
2. PRODUCT DESCRIPTION	4
2.1 Overview	4
2.2 Driver adapter	7
2.3 Sliding plate	8
2.4 PIN definition	9
3. CONNECTION DESCRIPTION	10
4. FOCUS REFERENCE SETTINGS	12
4.1 For cutting	12
4.2 For engraving	13
5. PRECAUTIONS	14
6. MAINTENANCE	14

1. PRODUCT INTRODUCTION

1.1 Parameters

Model	LT-K60
Optical power	20W/40W/60W (Adjustable)
Input	DC24V 10A
Wavelength	450nm (± 10 nm)
Focus length	40mm
Power adjustable	TTL/PWM
PWM modulation	0/3-12V, 0-5kHz
Interface	MR30 Port (DC 24V, GND, PWM)
Air assistance	Built-in airway
Fan speed	Dual fans, 6000rpm
Operating temperature	0-60°C
Module weight	1263g
Material	Aluminum & Copper
Application	Engraving & Cutting

1.2 Outline dimension (Unit: mm)

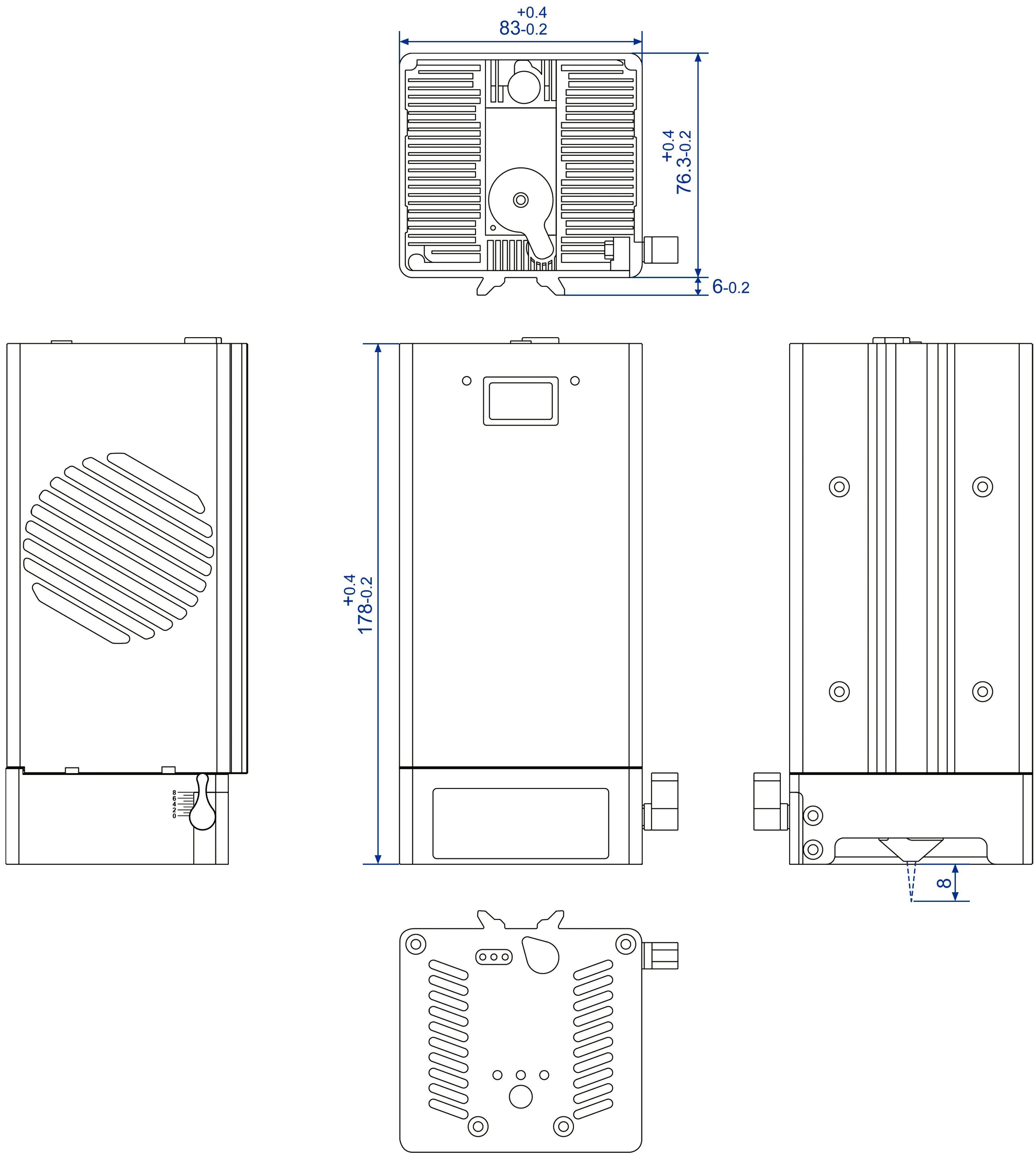

1.3 Packing list



Laser Module *1



Input Cable *1

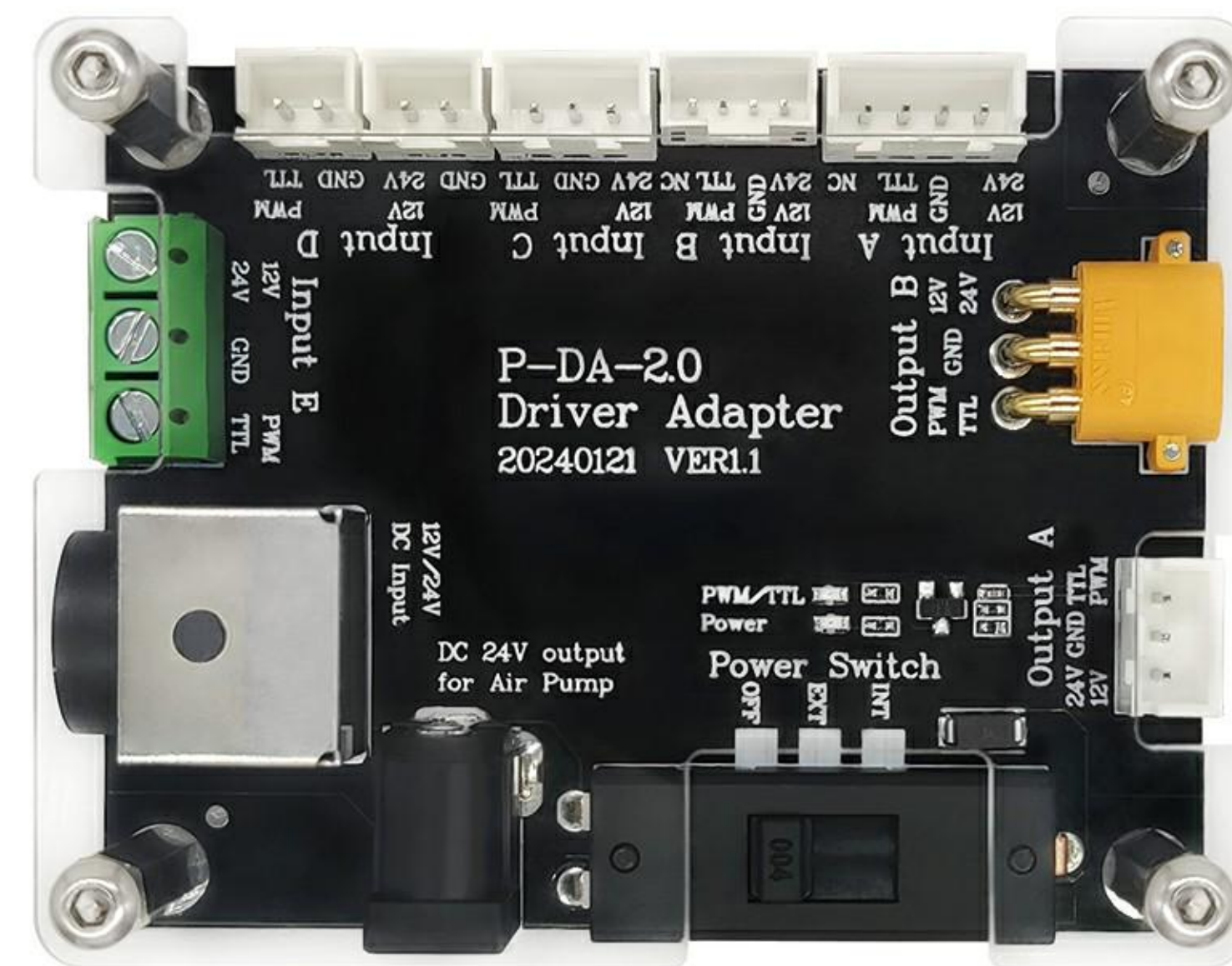

Driver Adapter2.0 *1



Spare protective lens *2

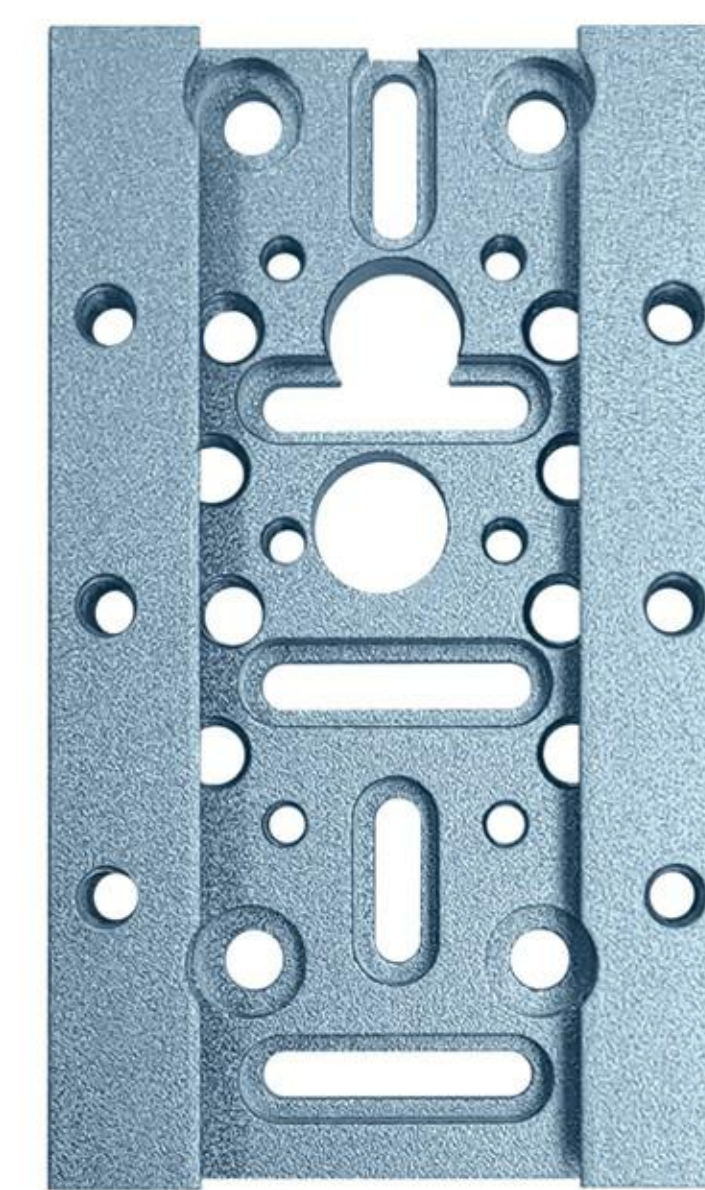

Sliding Plate *1



Adjusting screw M4*30 *2



2mm L-wrench *1



Air tube *1



Power Adapter*1



Power Cable *1

2. PRODUCT DESCRIPTION

2.1 Overview

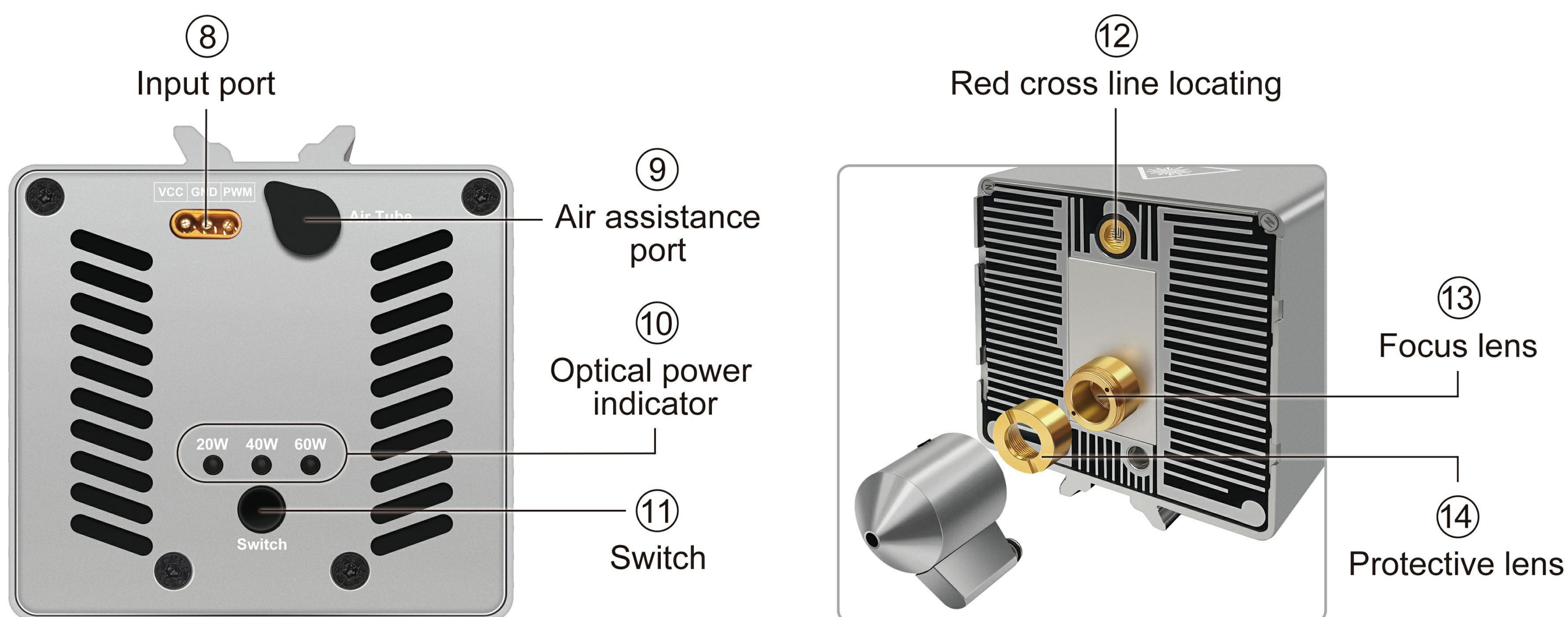
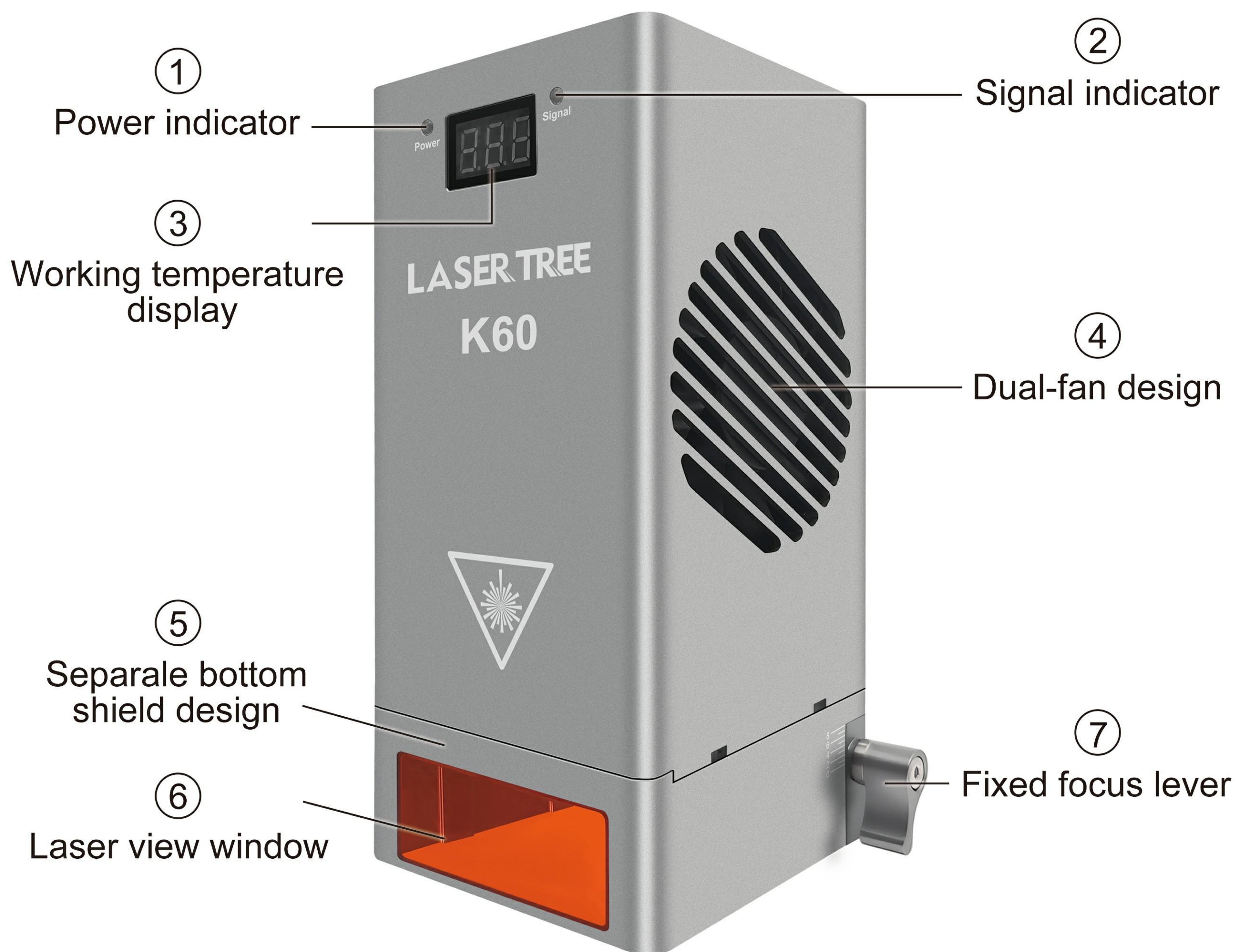

① Power indicator

It is red when power supply is connected.

② Signal indicator

It is green when signal is received.

③ Working temperature display

The output power stability and life time of laser module has strong relationship with working temperature of laser diode. LT-K60 built-in a thermistor at the highest temperature point near the laser diode, the operating temperature of the diode can be displayed on the digital tube in real-time.

When the working temperature of the laser module is higher than 55°C, the buzzer will sound an alarm.

To get good power stability and durability, it is suggested to keep the module working temperature below 55°C and environmental temperature below 35°C.

⑥ Laser view window

The optical glass window is fire-resistant and anti-blue light.

⑦ Fixed focus lever

Equipped with fixed focus lever, you can easily adjust the fixed focus distance according to different engraving and cutting requirements.

⑧ Input port

MR30 pluggable connector (24V, GND, PWM)

⑨ Air assistance port

Built-in air assist to get clean-cut edges and improve cutting performance.

Air pump suggestion:

- Air pressure and capacity: $\geq 0.027\text{kPa}$, 27L/min
- Air tube: outer diameter 8mm and inner diameter 5mm

⑪ Switch

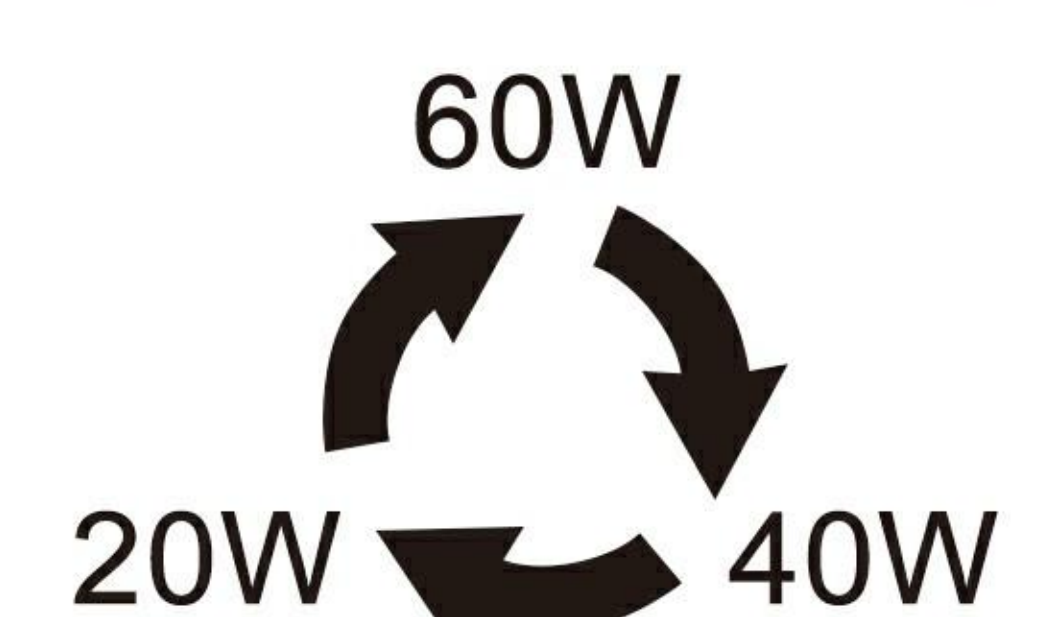
Function 1	Function 2	
When an over-temperature alarm occurs, press once can turn off the buzzer alarm sound.	The default power is 60W optical power, long press 5S to enter the power switching mode and switch to 40W optical power. Continuous short press can switch the optical power.	<p>Optical power switching order</p>  <p>The diagram shows a circular flow of arrows indicating the switching order between three power levels: 60W at the top, 40W at the bottom right, and 20W at the bottom left. Arrows connect 60W to 40W, 40W to 20W, and 20W back to 60W.</p>

⑫ Red cross line locating

Help you to place the material to the position correctly.

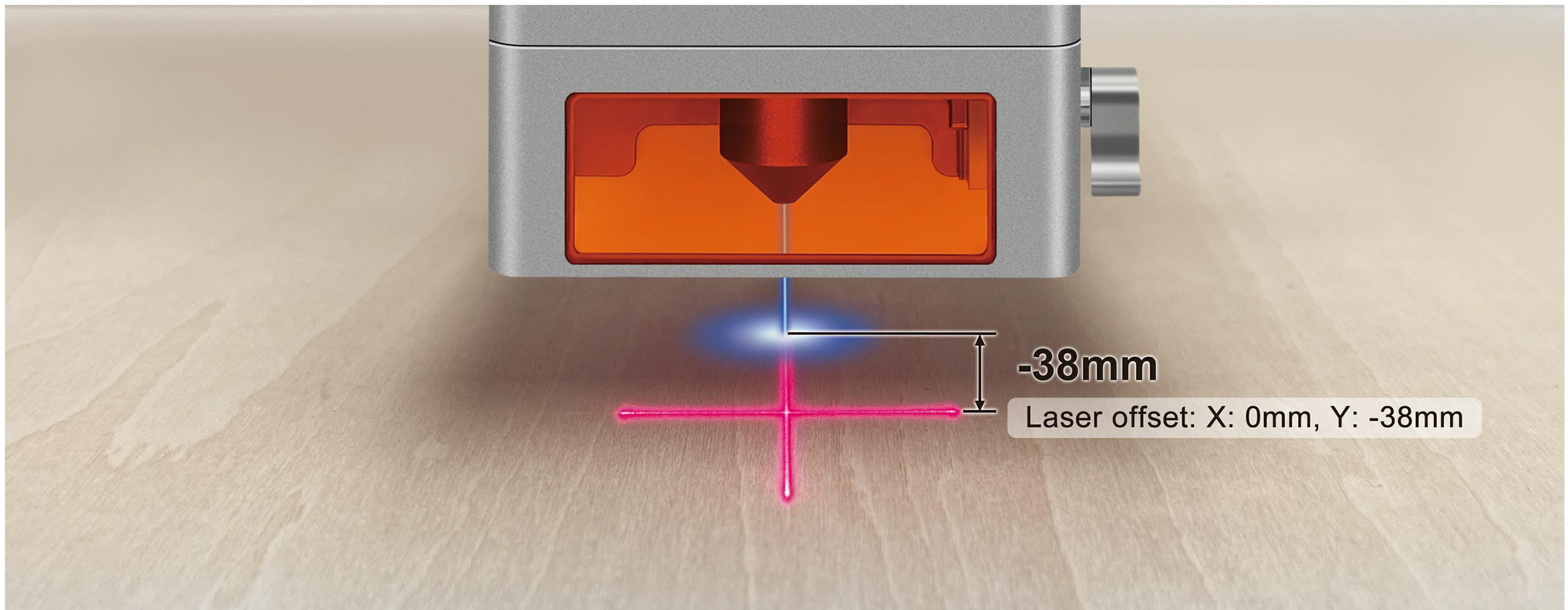

LightBurn settings

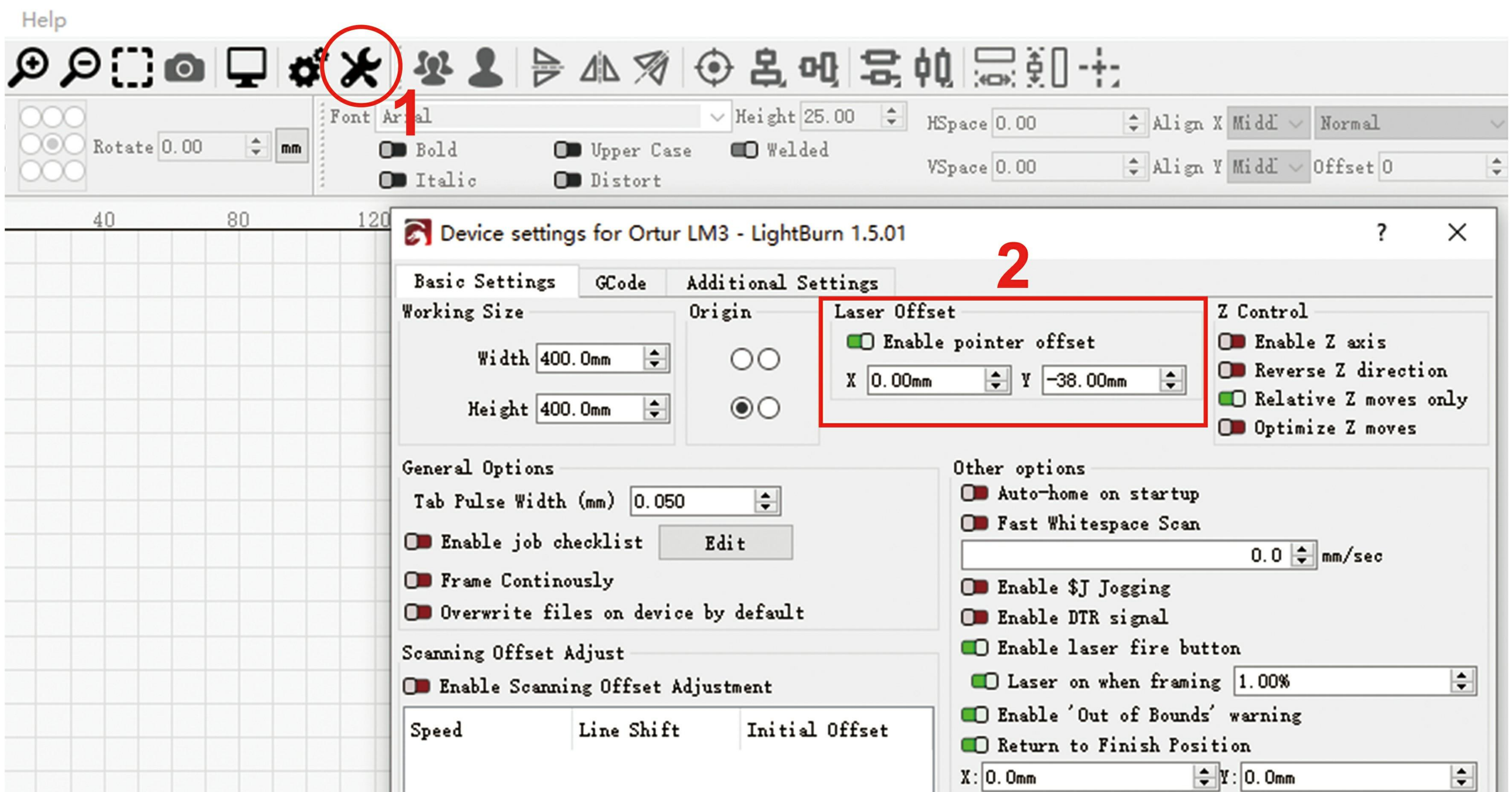

2.2 Driver adapter (Model: P-DA-02)

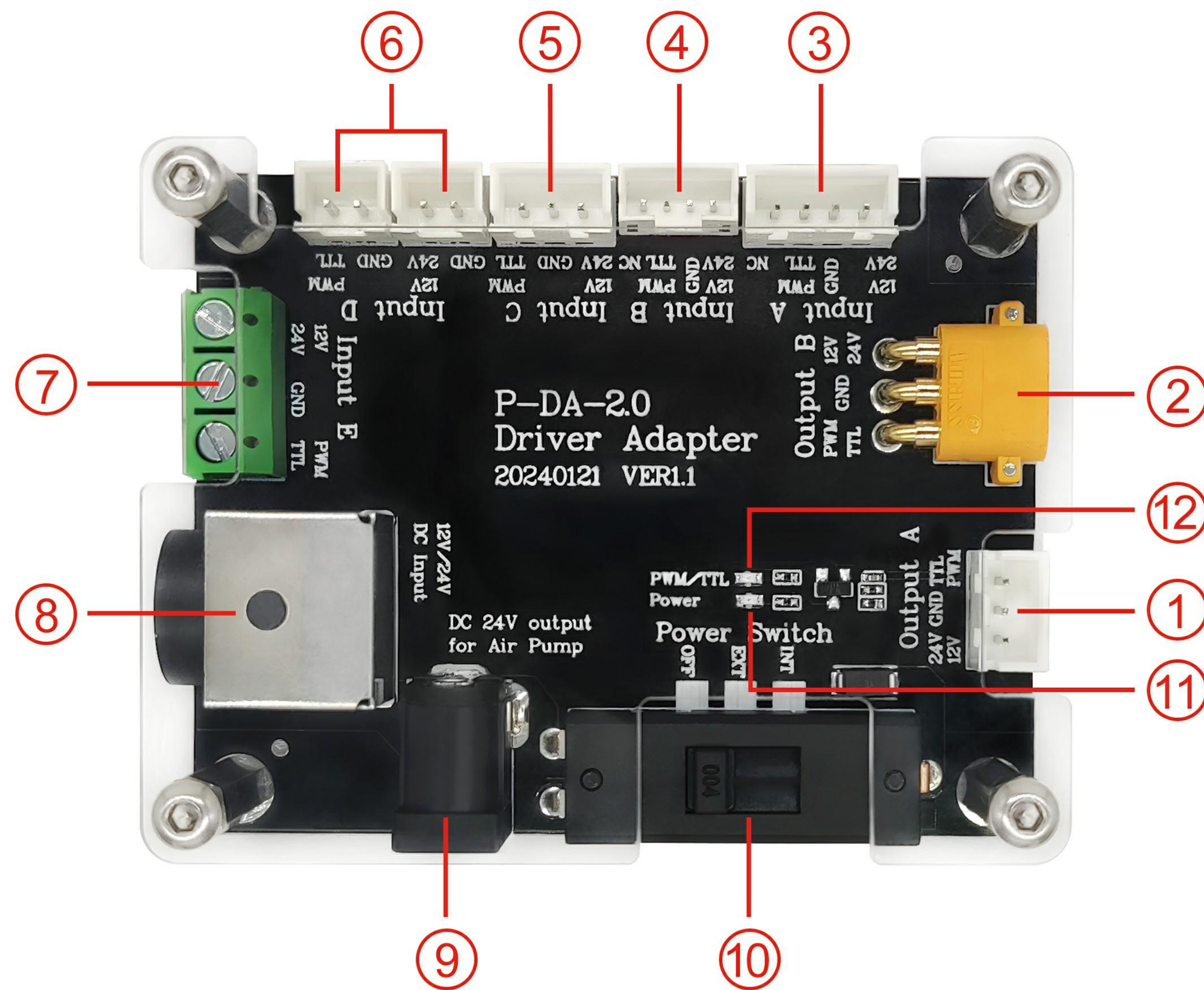

① Output A: XH2.54-3Pin	② Output B: MR30-M
③ Input A: XH2.54-4Pin	④ Input B: PH2.0-4Pin
⑤ Input C: XH2.54-3Pin	⑥ Input D: XH2.54-2Pin
⑦ Input E: KF350-3Pin	⑧ 12V/24V DC Input: 4Pin
⑨ 24V output for air pump: DC5.5*2.1mm	
⑩ Power Switch: • OFF—Power off • EXT—External power supply • INT—Internal power supply	
⑪ TTL/PWM indicator: It is green when the TTL/PWM signal is received.	
⑫ Power indicator: It is red when the power cable is connected correctly.	

2.3 Sliding plate

Multiple holes bring you widely installation compatibility.

Outline dimension (Unit: mm)

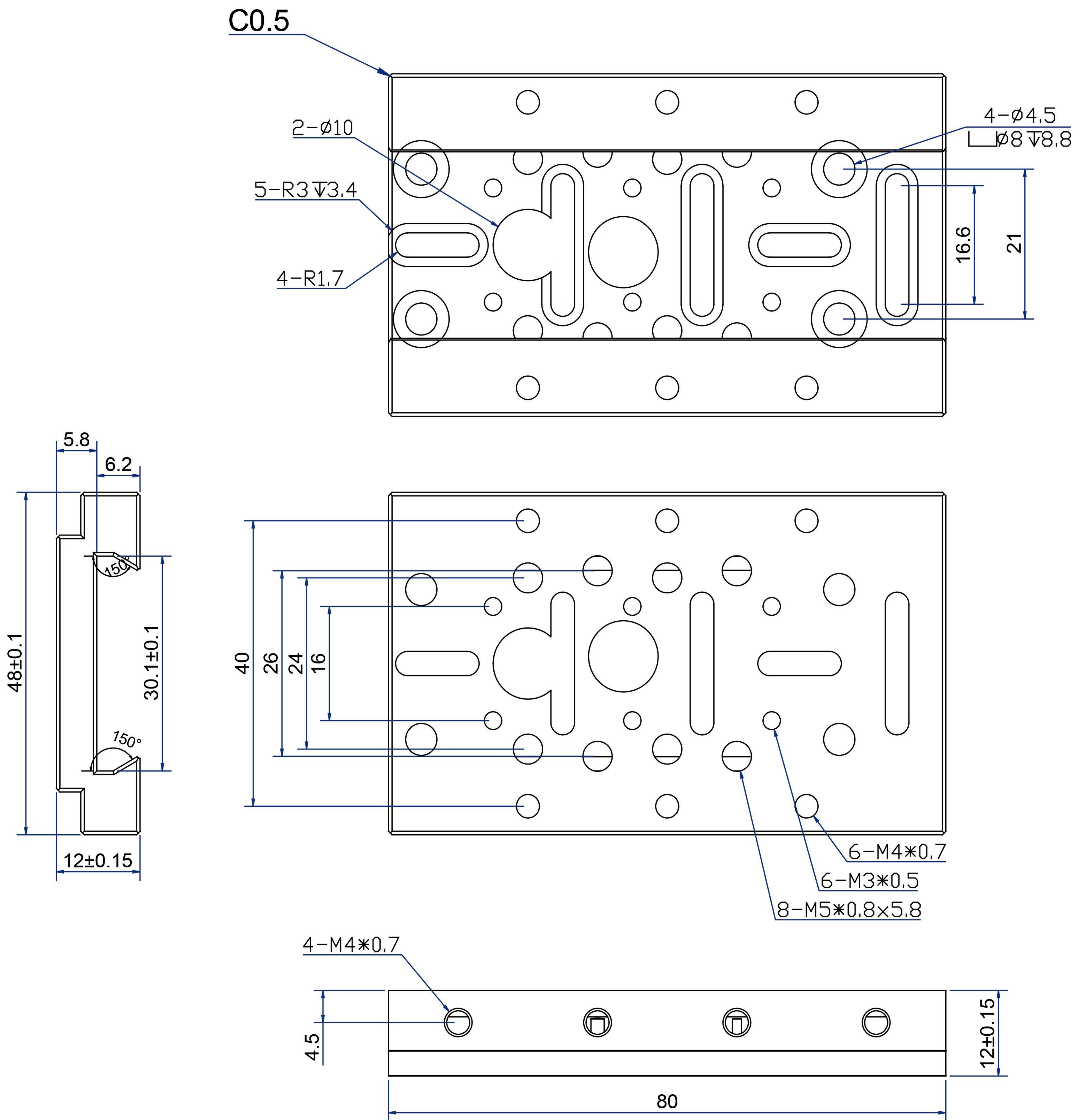

Installation for sliding plate

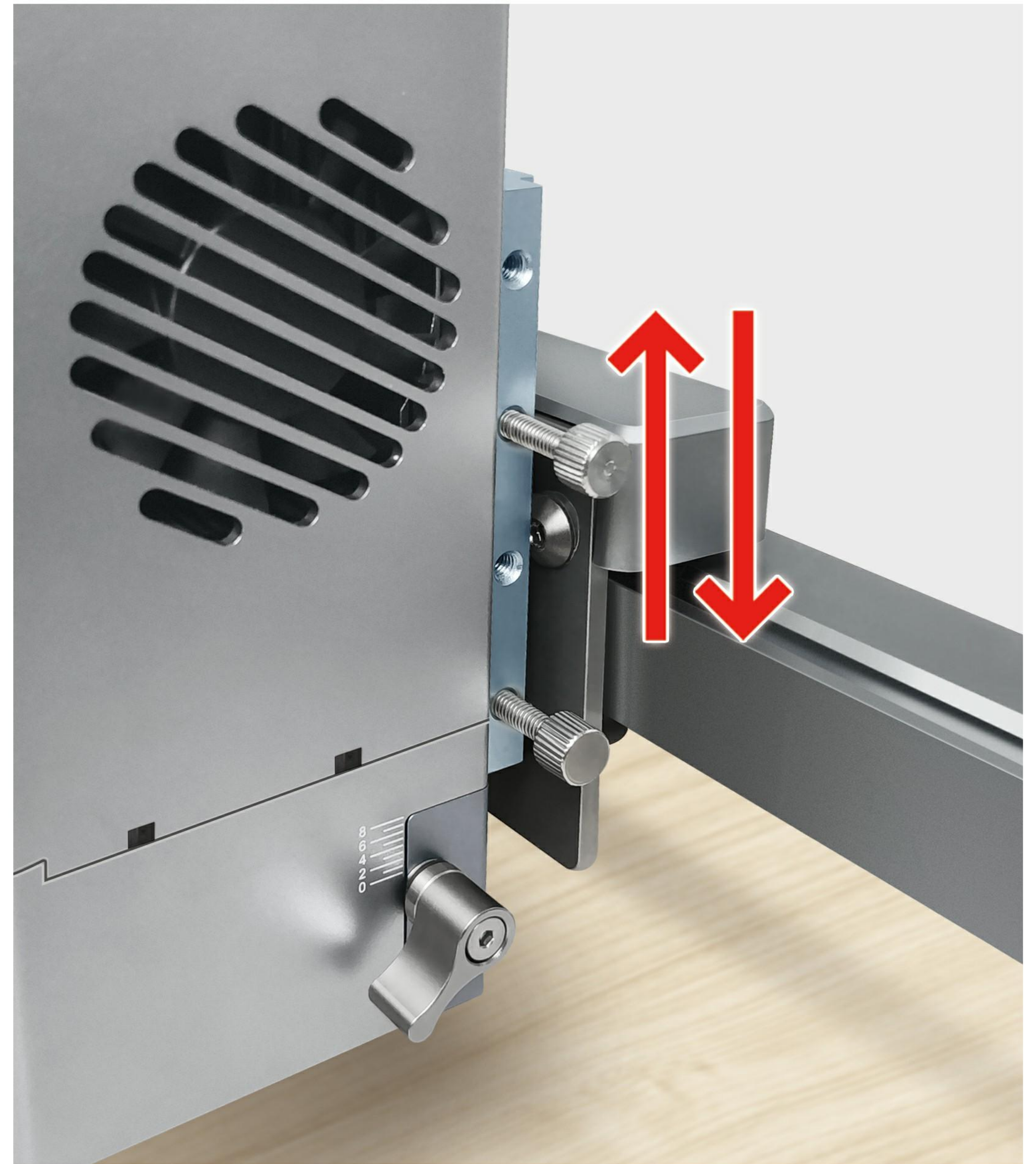
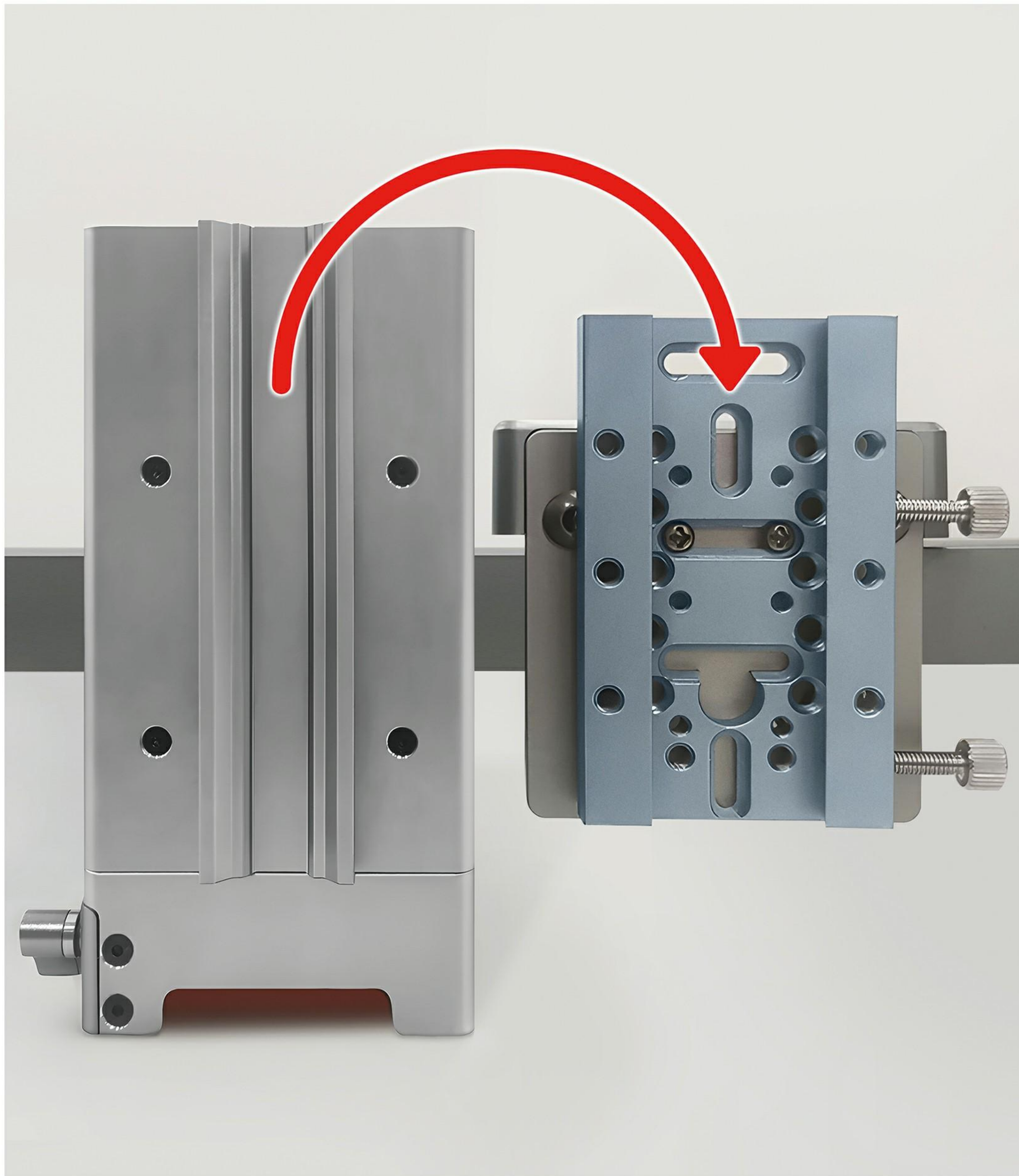

2.4 PIN definition



3. CONNECTION DESCRIPTION

Please check whether there is a PWM/TTL and GND output port on the engraver main board before connection.

- Step1** Connect one end of the input cable to the laser module and the other end to the corresponding output B port on the driver adapter.



- Step2** Connect the 24V power adapter to the DC input connector on driver adapter. Push the switch to "EXT" position and the power is provided by external power adapter.

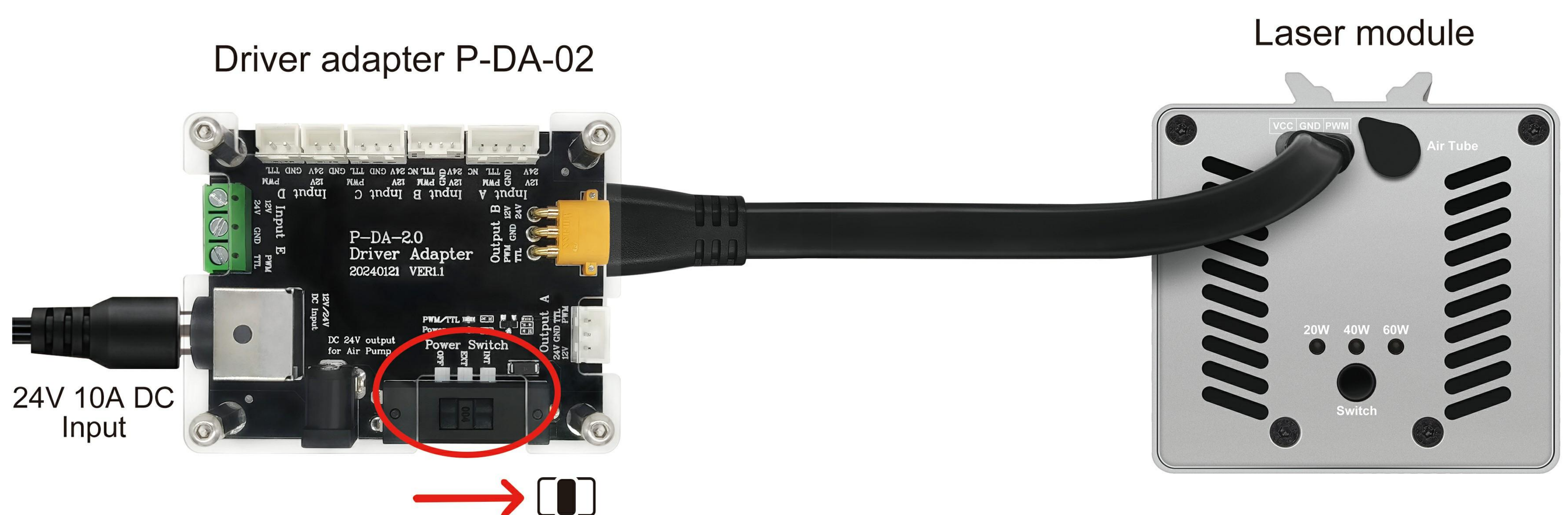

Step3

Connect the engraving machine main board cable to the corresponding input port on drive adapter.

(The picture below is a connection example. For more Input ports, please refer to the driver adapter description on page 7.)

Engraving machine main board

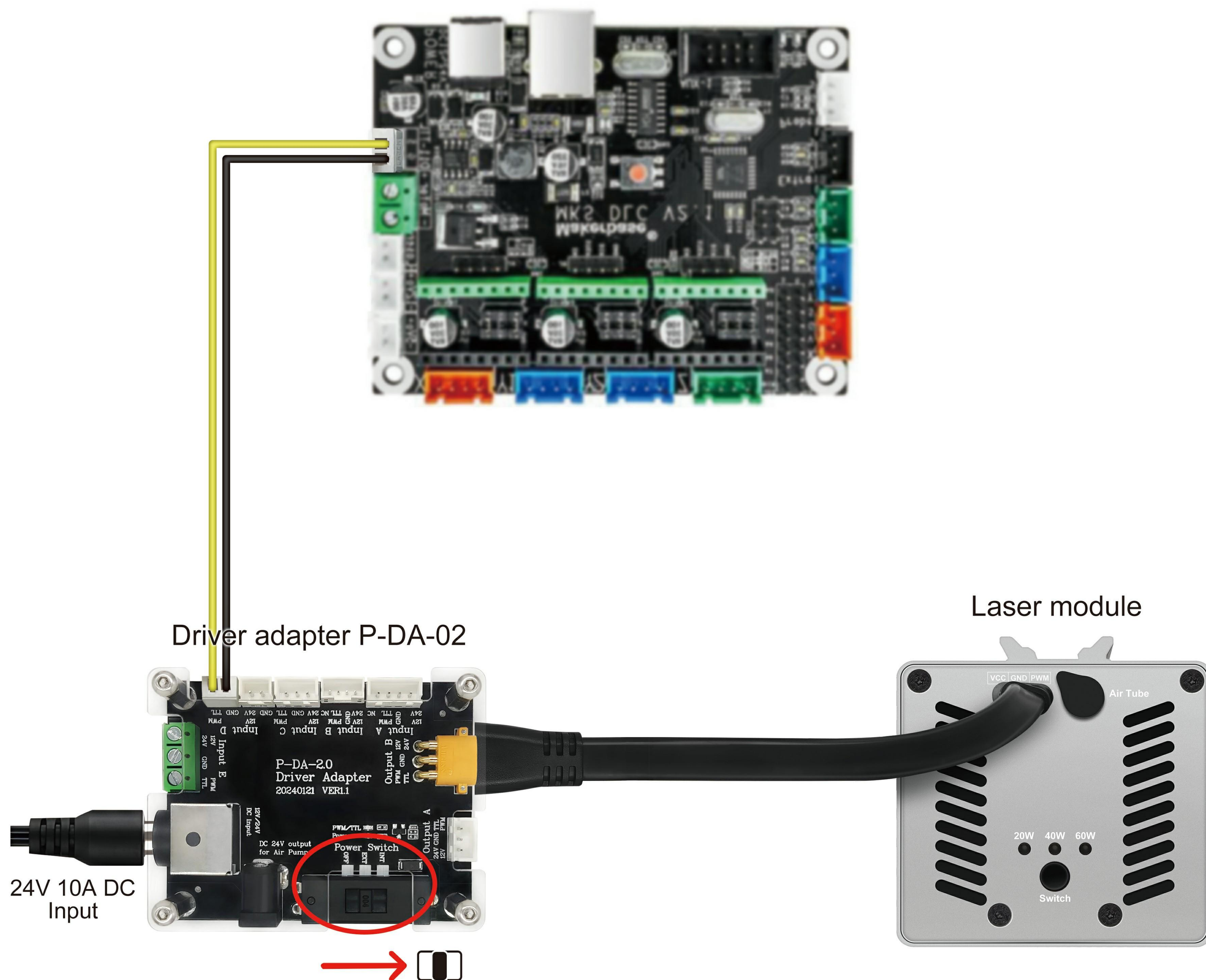

4. FOCUS REFERENCE SETTINGS

The focus length of LT-K60 is 40mm.

4.1 For cutting

Please make the focus locate lower than the cutting material surface according to the following.

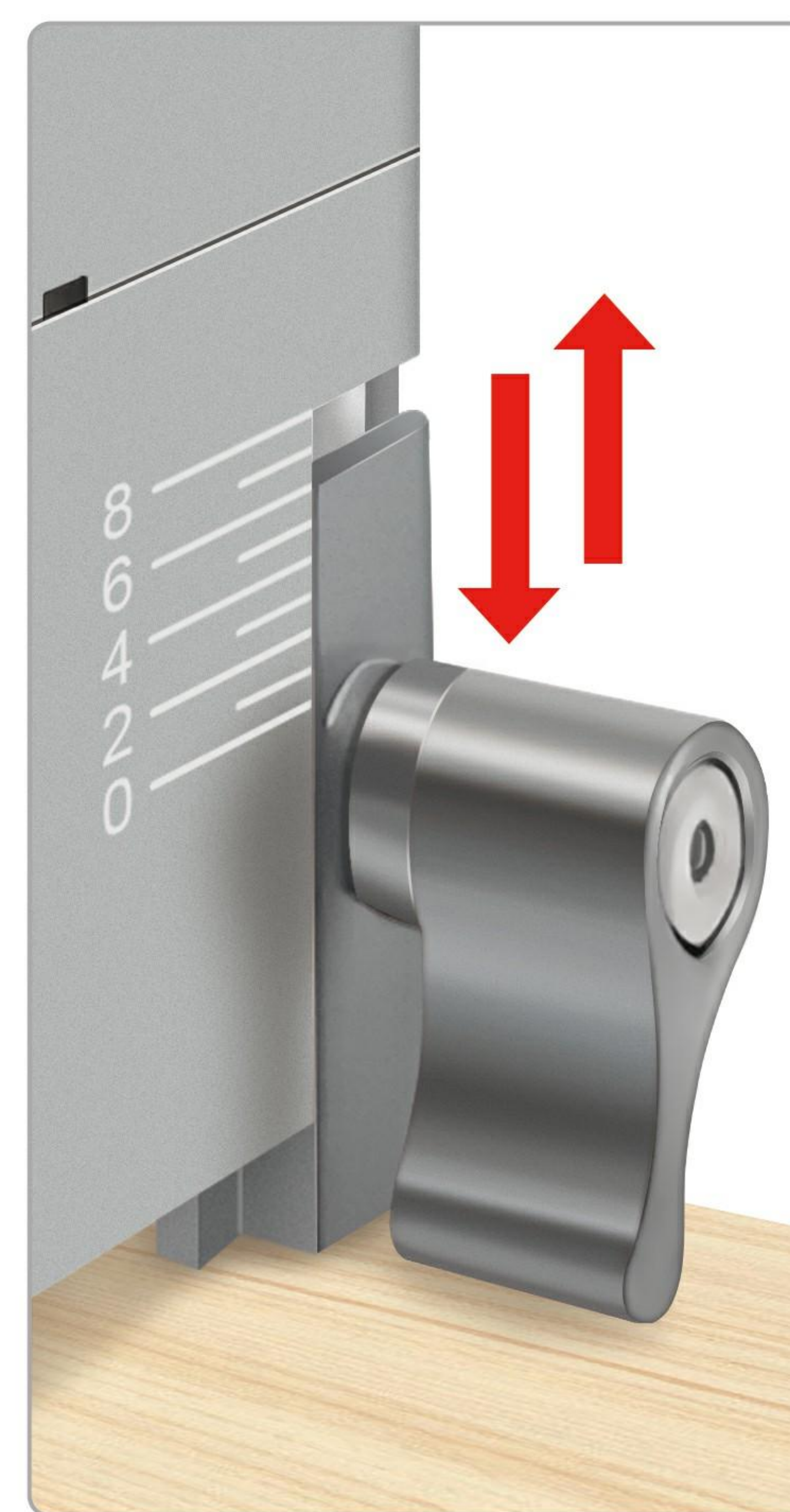
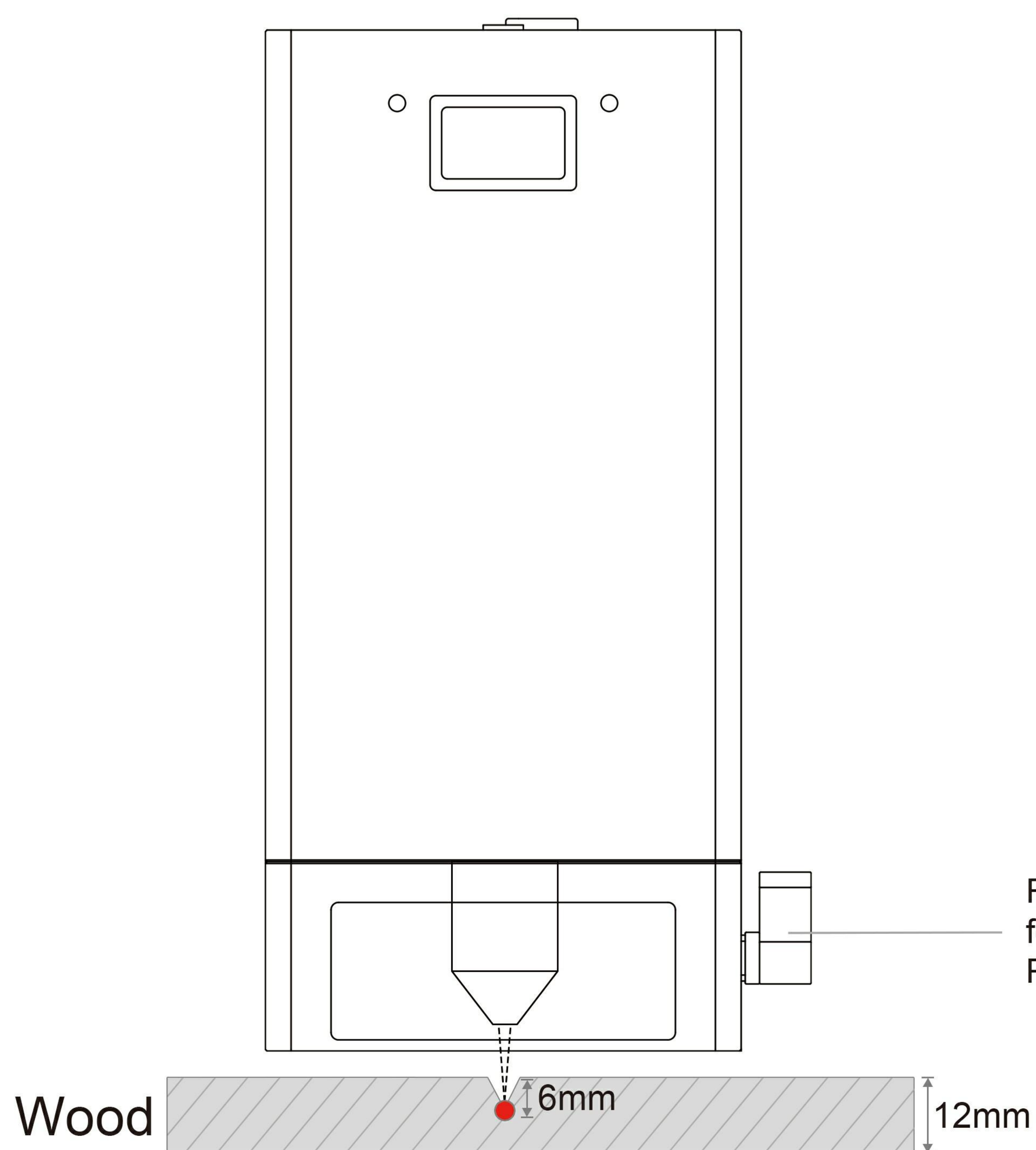

For example, if you want to cut 12mm material, the focus should be 6mm lower than material surface. Please adjust the fixed focus lever to 6mm.

Reference settings for cutting							
Material thickness	< 5mm	5mm	8mm	10mm	12mm	15mm	≥ 30mm
Fixed focus lever	0mm	2mm	4mm	5mm	6mm	7mm	7mm

4.2 For engraving

Please make the focus locate on the engraving material surface.

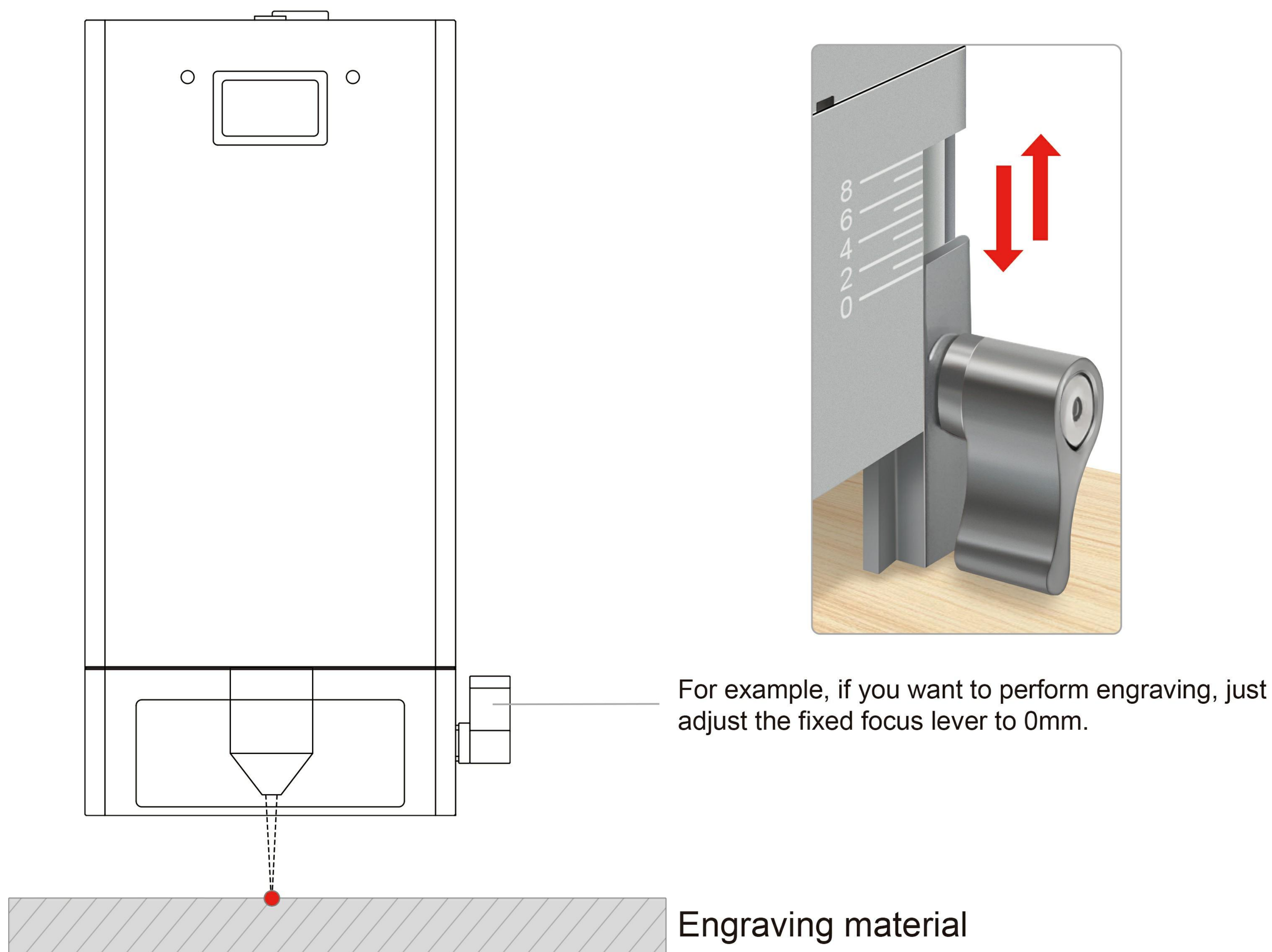

Reference settings for engraving

Parameter Material	Fixed focus lever (mm)	Speed (mm/min)			Max Power			Line Interval
		20W	40W	60W	20W	40W	60W	
Basswood Plywood	0	12000	15000	18000	50%	45%	30%	0.05
Pine Board	0	10000	12000	15000	55%	50%	40%	0.05
Corrugated Board	0	15000	18000	20000	22%	18%	13%	0.05
Stainless Steel	0	9000	10000	13000	60%	70%	80%	0.01
Titanium plate	0	9600	10800	12000	32%	36%	40%	0.05

5. PRECAUTIONS



Laser may cause damage to your skin. Please do not expose your skin directly to the laser.



Please wear laser goggles to protect your eyes when you use this laser module.



Please ensure that the air pump is turned on before you start cutting. If not, the smoke will contaminate the lens.



This laser module doesn't support hot plug. Hot plug may cause damage to the laser module.

6. MAINTENANCE



When the laser module is not used for a long time, please ensure that the lens is not polluted by dust.



When you replace the air nozzle, please ensure that your operation will not pollute the lens. Finger prints or dust on the lens will weaken the output power of the laser module, or even damage the lens.



When you find the cutting ability of laser module decreased, the lens might be not clean. Please use a clean alcohol swab to clean it according to the following figure.

* For more information about maintenance, please contact us at lasertree@micost-optotech.com.

⚠ Caution for lens cleaning:

- Make sure the engraving module is disconnected from the power supply before wiping the lens.
- After wiping, allow the lenses to dry naturally for 3 to 5 minutes before use.

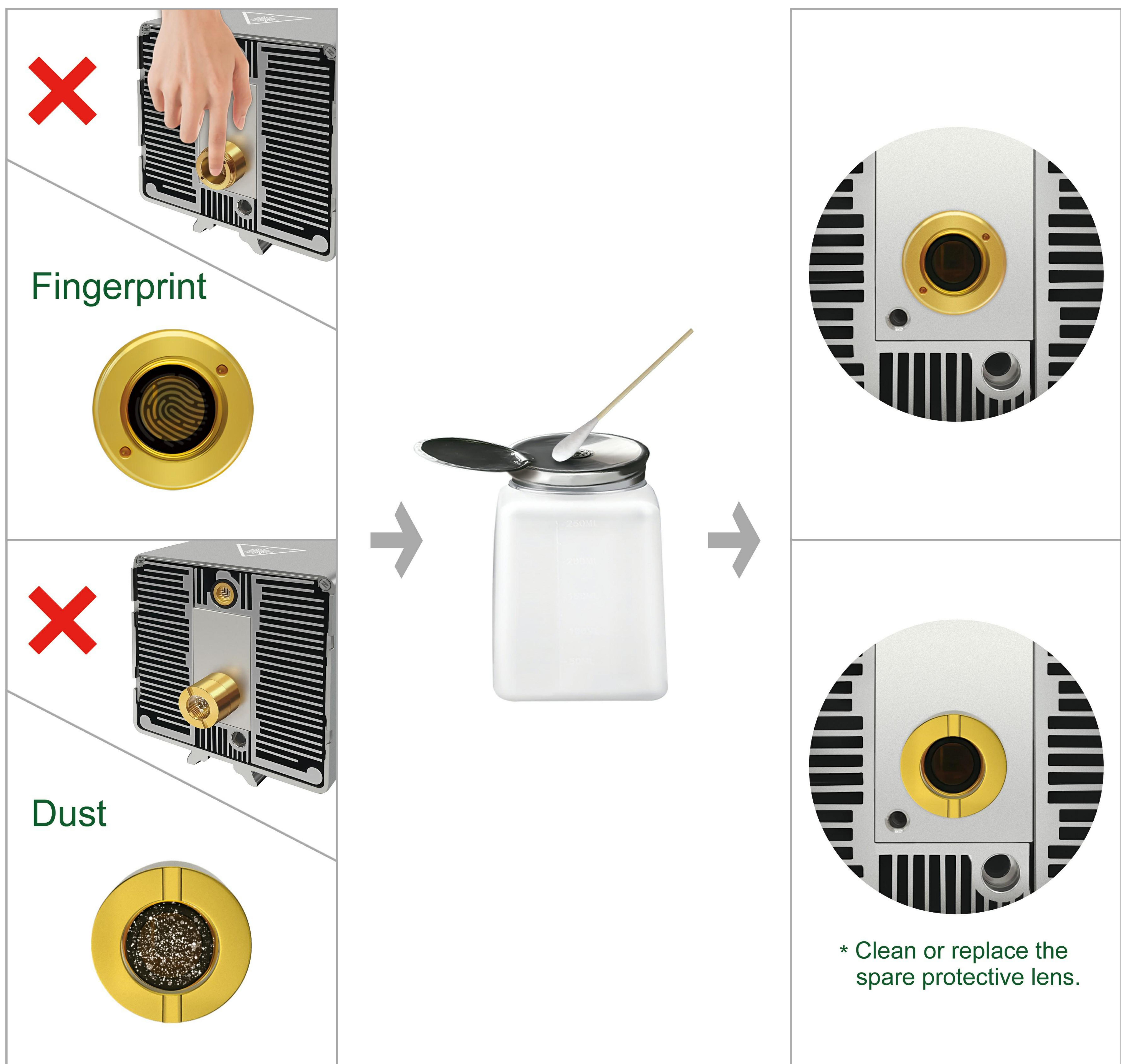



LASER TREE

Enjoy pleasure of DIY

CE FCC RoHS  

MADE IN CHINA