



K20

USER MANUAL

CONTENT

1	PRODUCT INTRODUCTION	1
	Parameters	1
	Outline dimension	2
	Packing list	3
2	PRODUCT DESCRIPTION	4
	Overview	4
	Driver adapter	8
	Sliding plate	9
	PIN definition	10
3	CONNECTION DESCRIPTION	11
4	FOCUS REFERENCE SETTINGS	15
	For cutting	15
	For engraving	16
5	PRECAUTIONS	17
6	MAINTENANCE	17

1. PRODUCT INTRODUCTION

Parameters

Optical power:	19W-21W
Input:	24V4A
Wavelength:	450nm (± 10 nm)
Focus length:	40mm
Air assistance:	Built-in airway
Power adjustable:	TTL/PWM
PWM modulation:	0/3-12V, 0-5kHz
Fan speed:	6000rpm
Operating temperature:	0-60°C
Interface:	2EDG-3.81
Cable:	3PIN, 80cm
Material:	Aluminum & Copper
Module weight:	635g
Application:	Engraving & Cutting

 Outline dimension (Unit: mm)

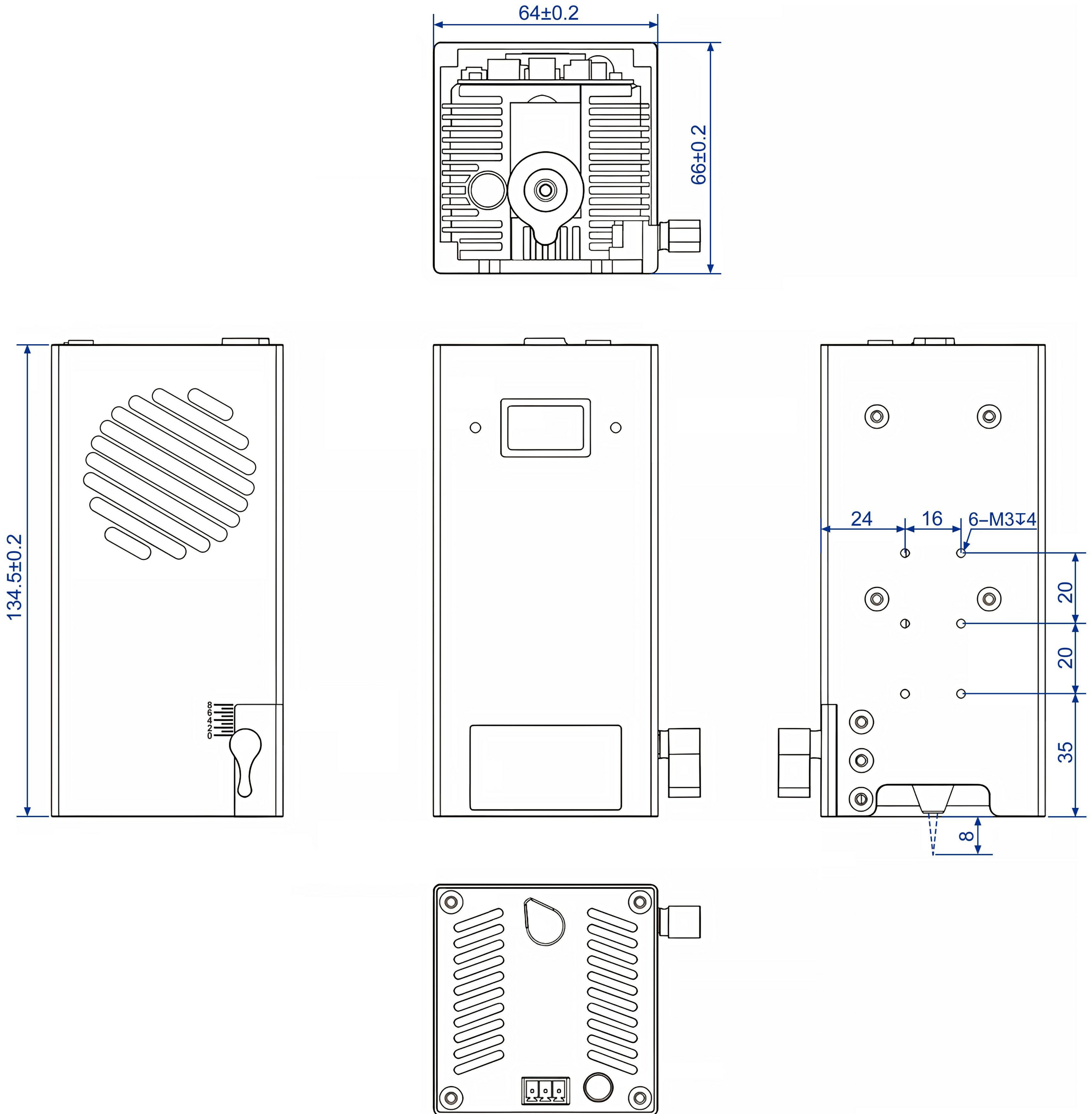

 Packing list



Laser module



Sliding plate



2mm L-wrench

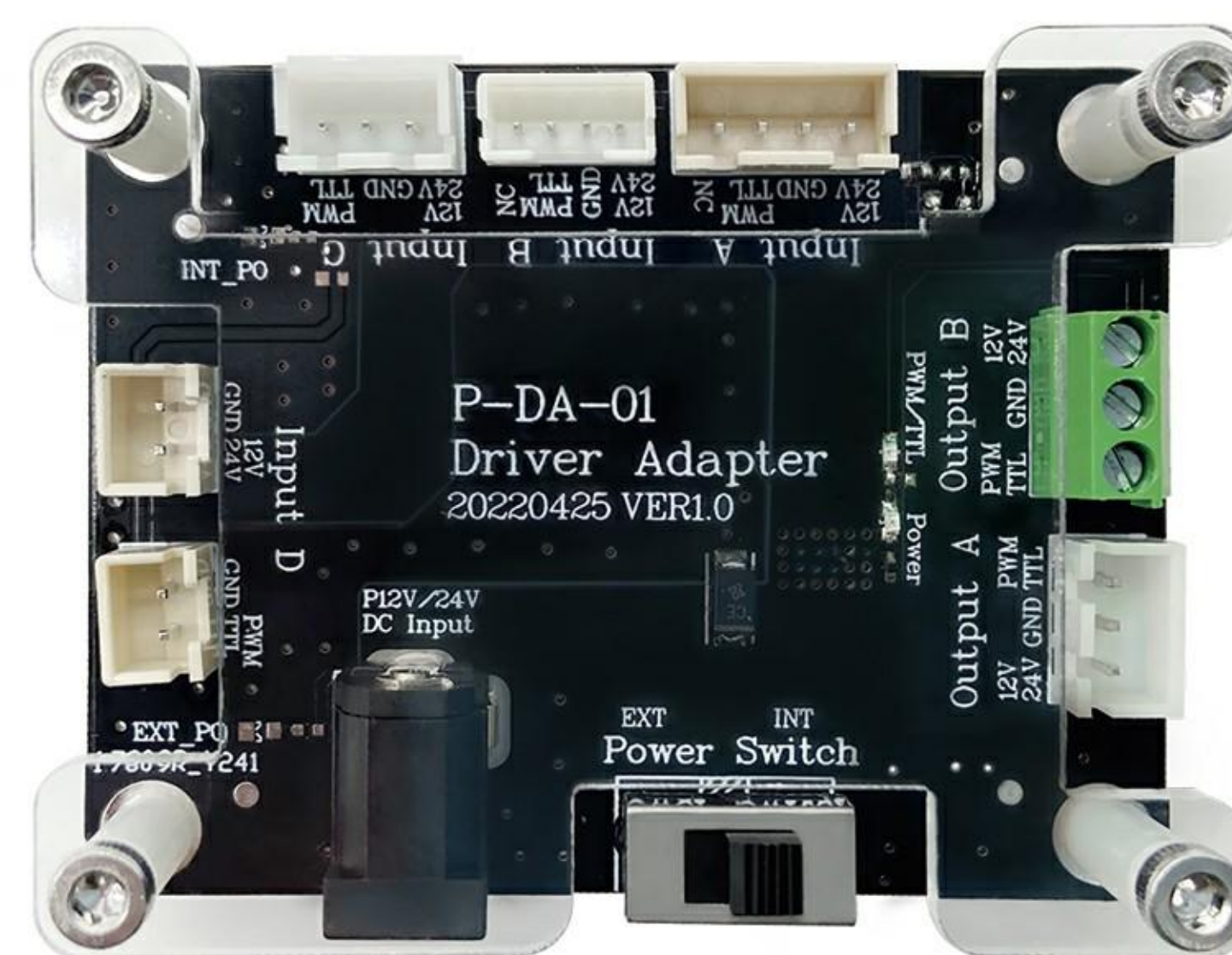

Driver adapter



24V4A power supply



Spare protective lens



1.5m Air tubex1

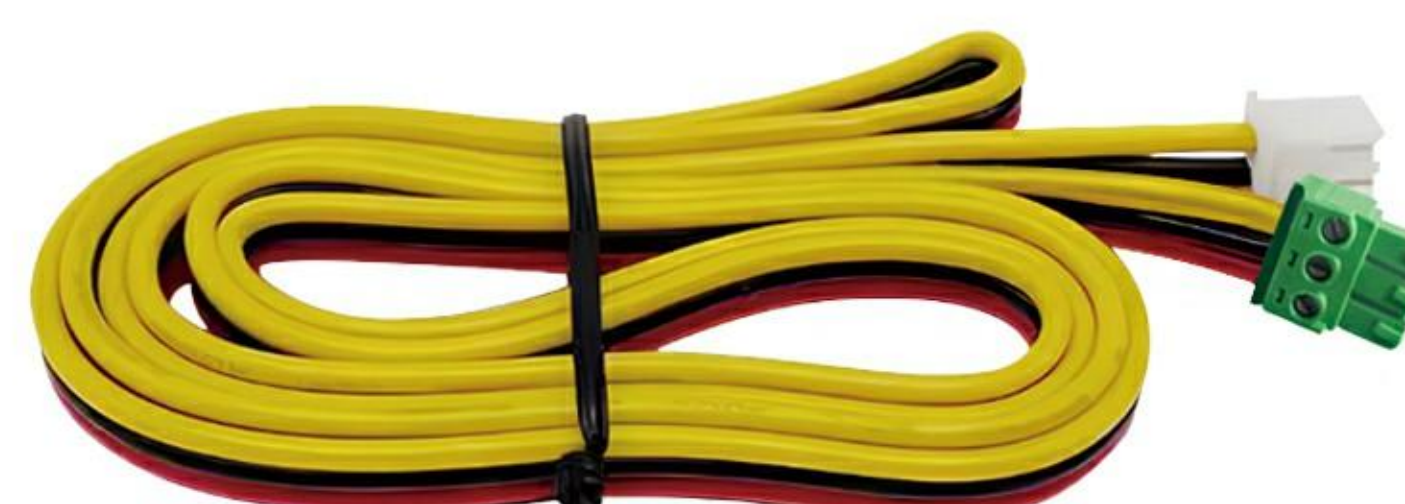

80cm Input cable

2. PRODUCT DESCRIPTION

Overview

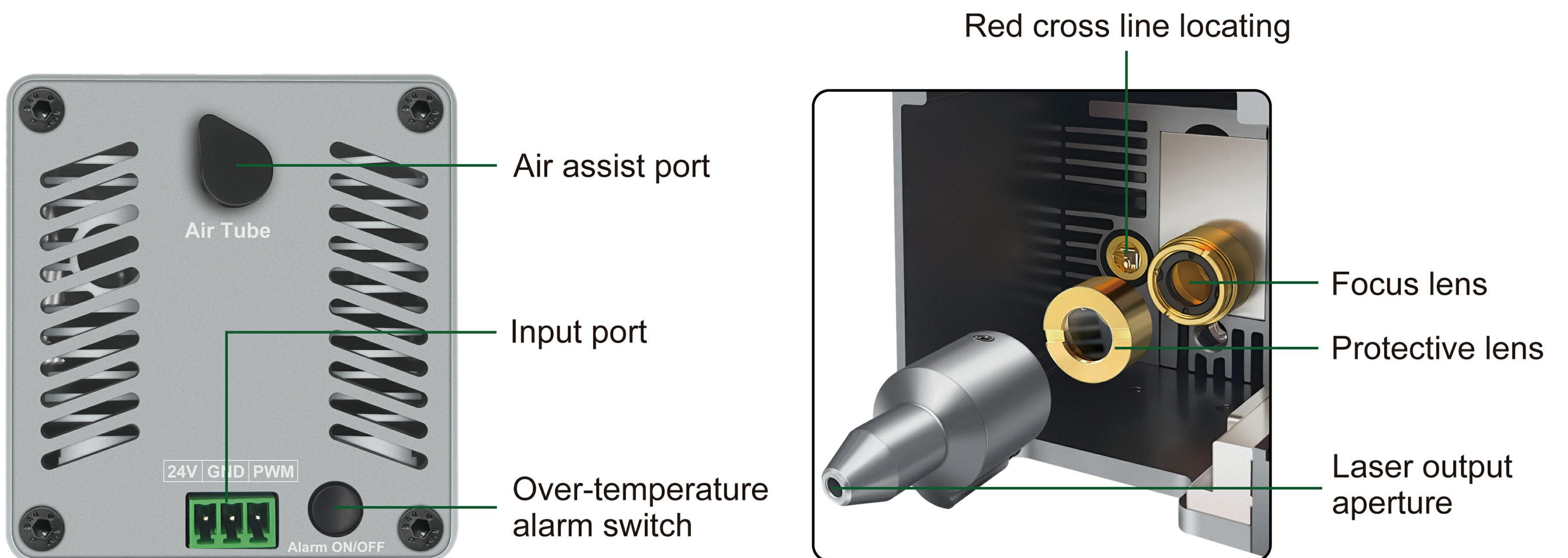
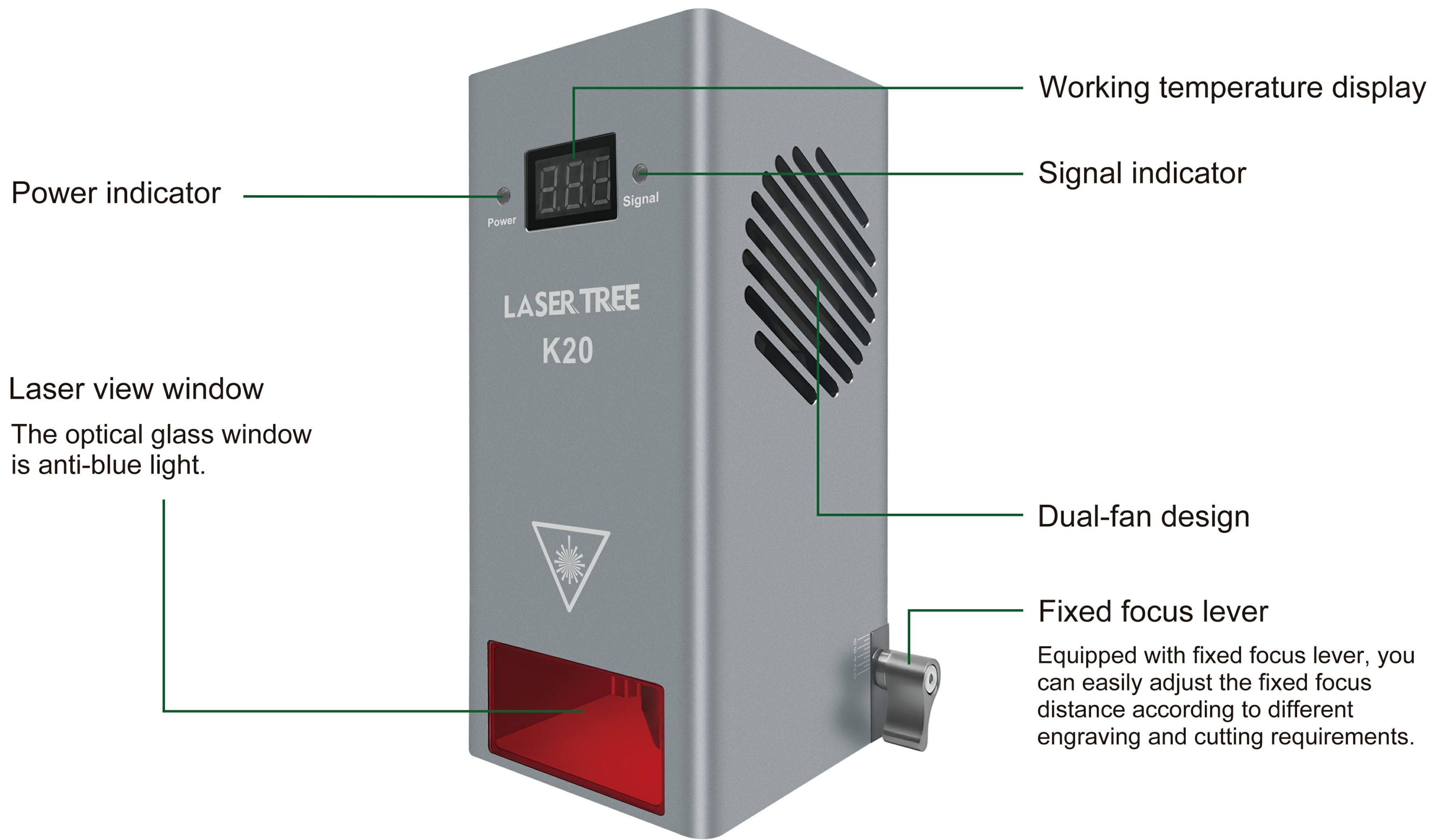

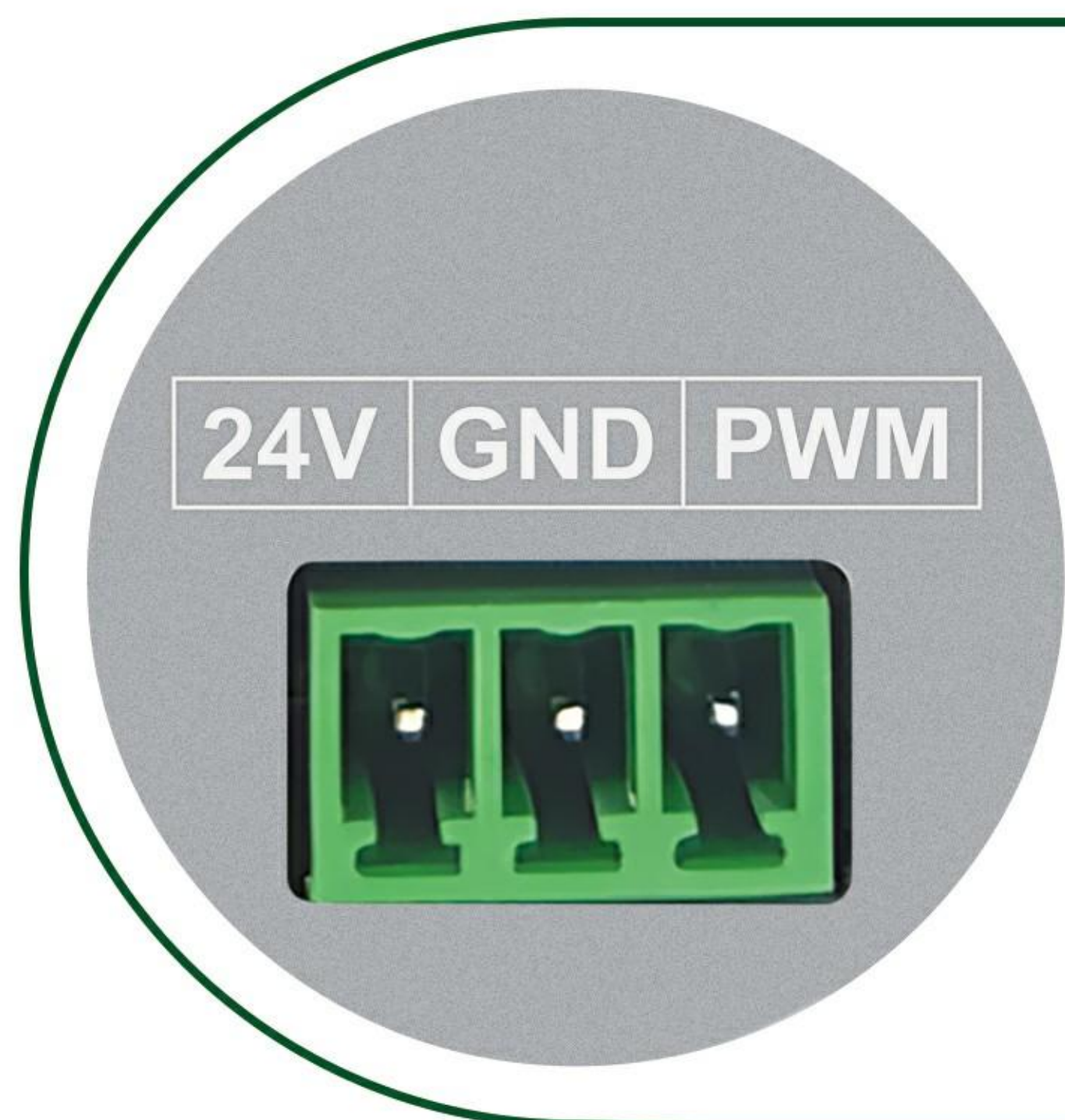

Input port

Use 2EDG3.81 pluggable connector.

- VCC (24V5A DC)
- GND
- TTL/PWM in (0-5kHz)

Air assistance port

Built-in air assist to get clean-cut edges and improve cutting performance.

Air pump suggestion:

- Air pressure and capacity: $\geq 0.027\text{kPa}$, 27L/min
- Air tube: outer diameter 6mm and inner diameter $\geq 4\text{mm}$



Working temperature display



The output power stability and life time of laser module has strong relationship with working temperature of laser diode. K30 built-in a thermistor at the highest temperature point near the laser diode, the operating temperature of the diode can be displayed on the digital tube in real-time.

We suggest the working temperature of the laser module is controlled below 55°C and the working environmental temperature below 35°C to get good power stability and durability.

Over-temperature alarm switch

When the working temperature of the laser module is higher than 55°C , the buzzer will sound an alarm.



Working status indicator

Power indicator: it is red when power supply is connected.

Signal indicator: it is green when signal is received.

✚ Red cross line locating

Help you to place the material to the position correctly.



Before

VS

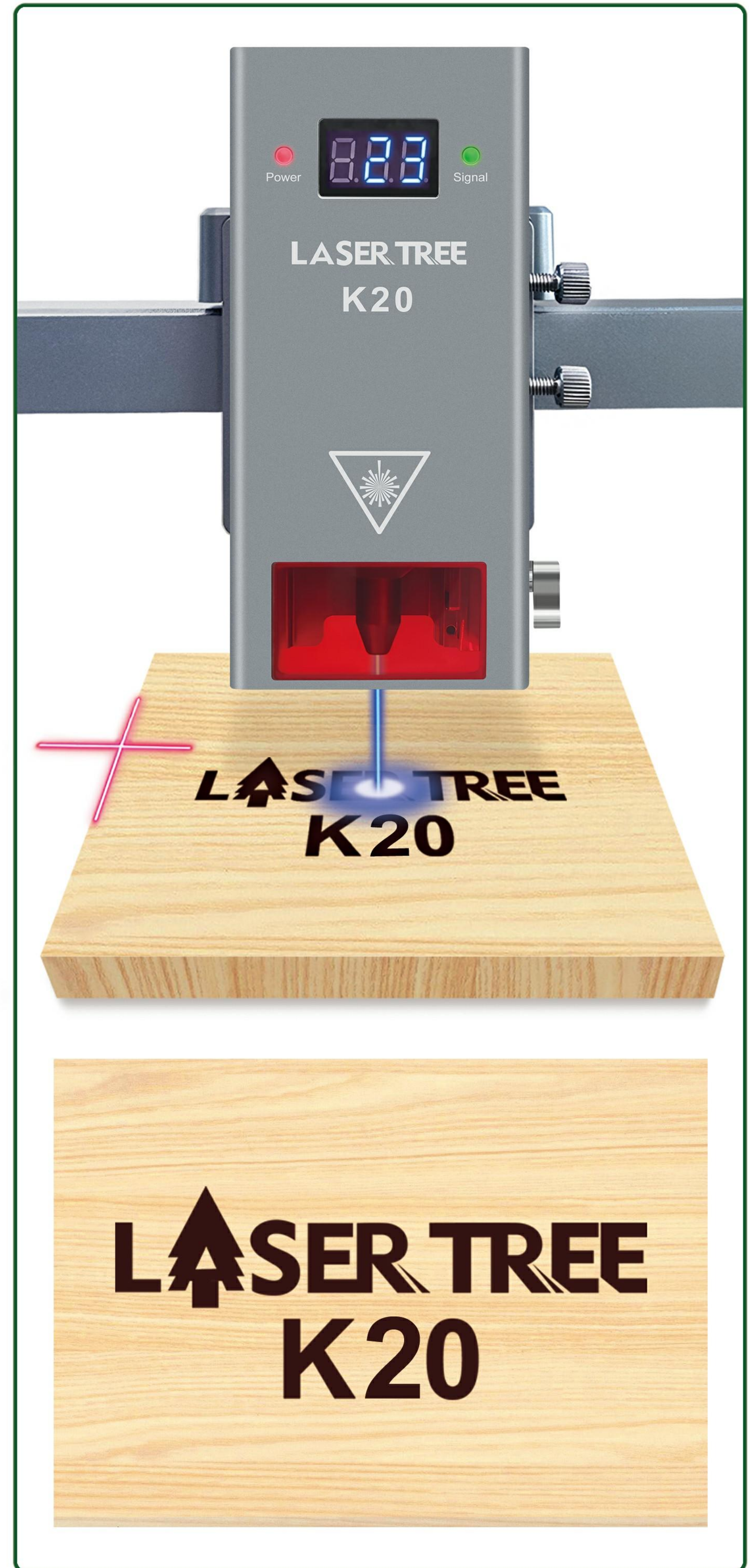

After

Focus positioning setting reference.

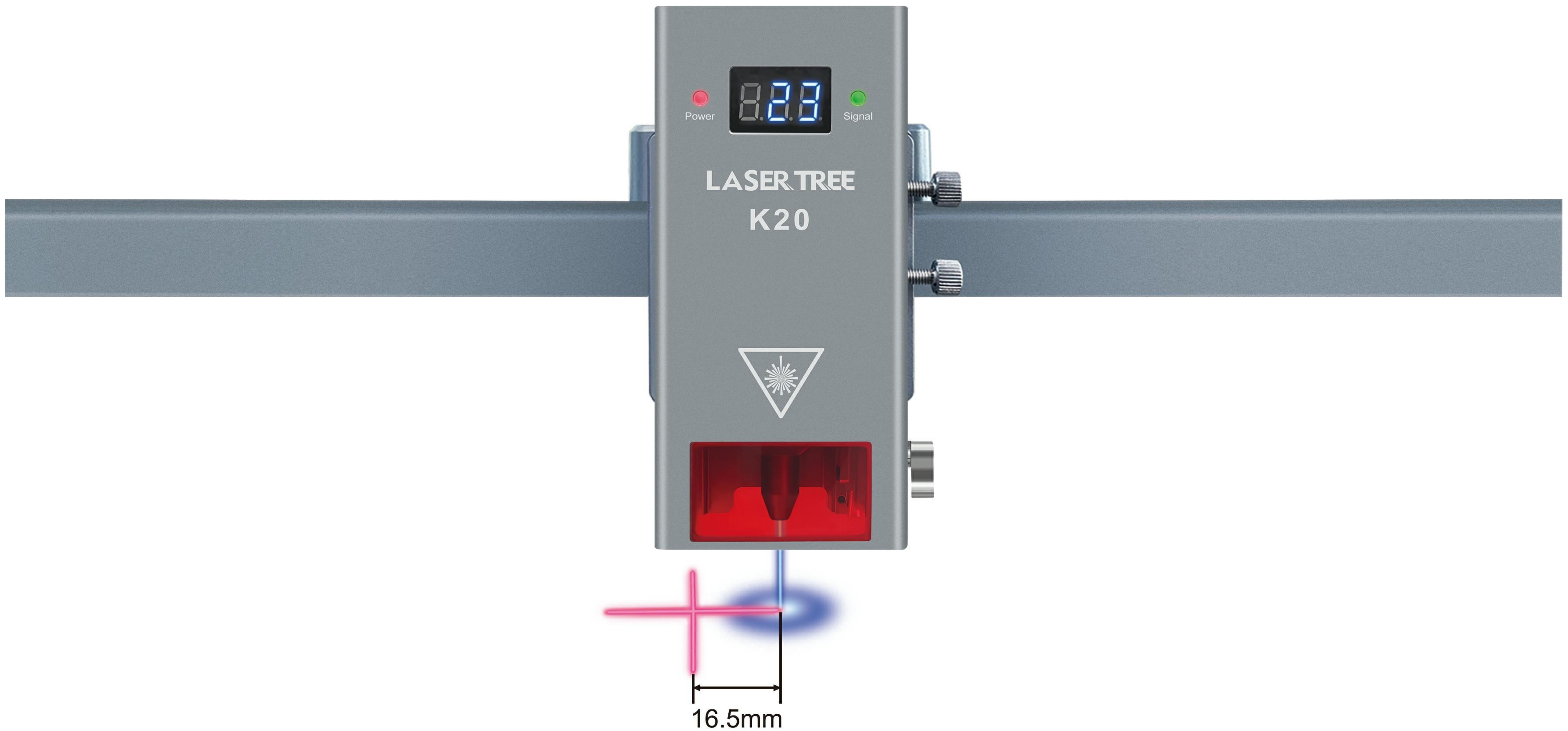

LightBurn Software settings

→ Device setting → Laser offset → X axis: -16.5mm

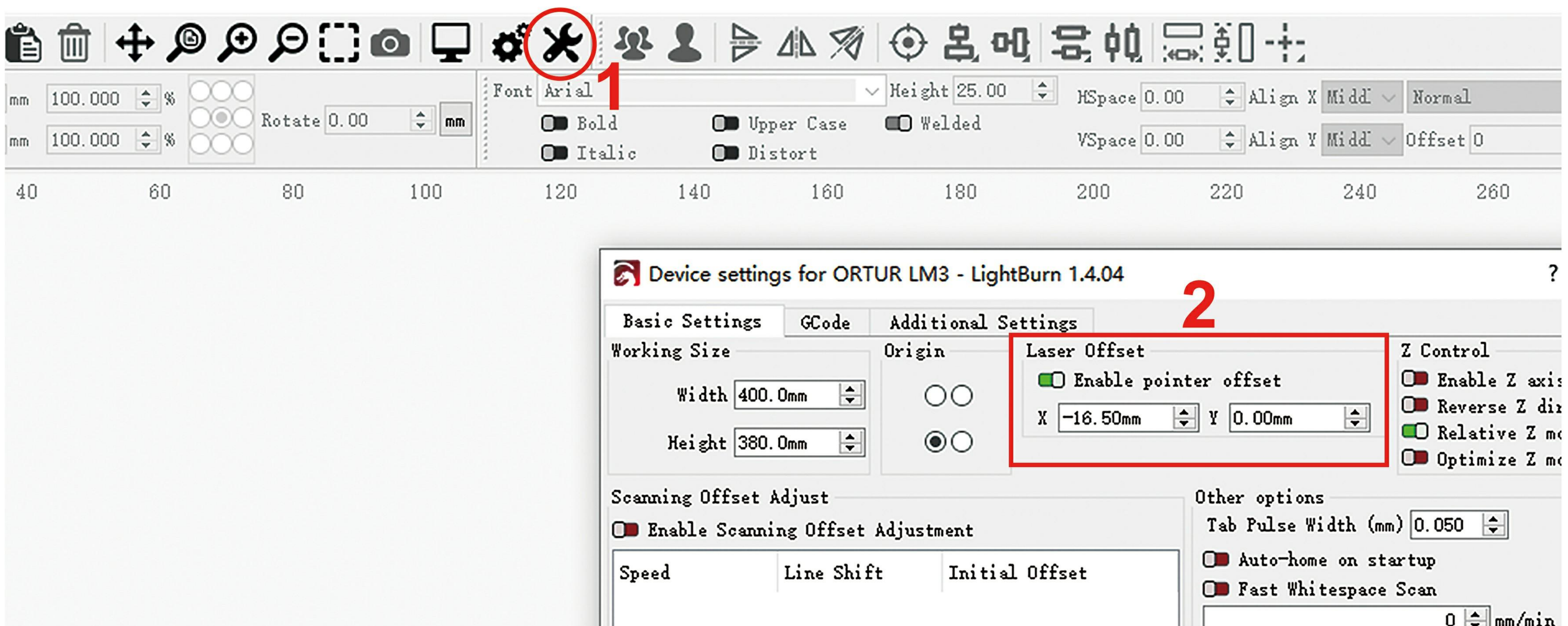

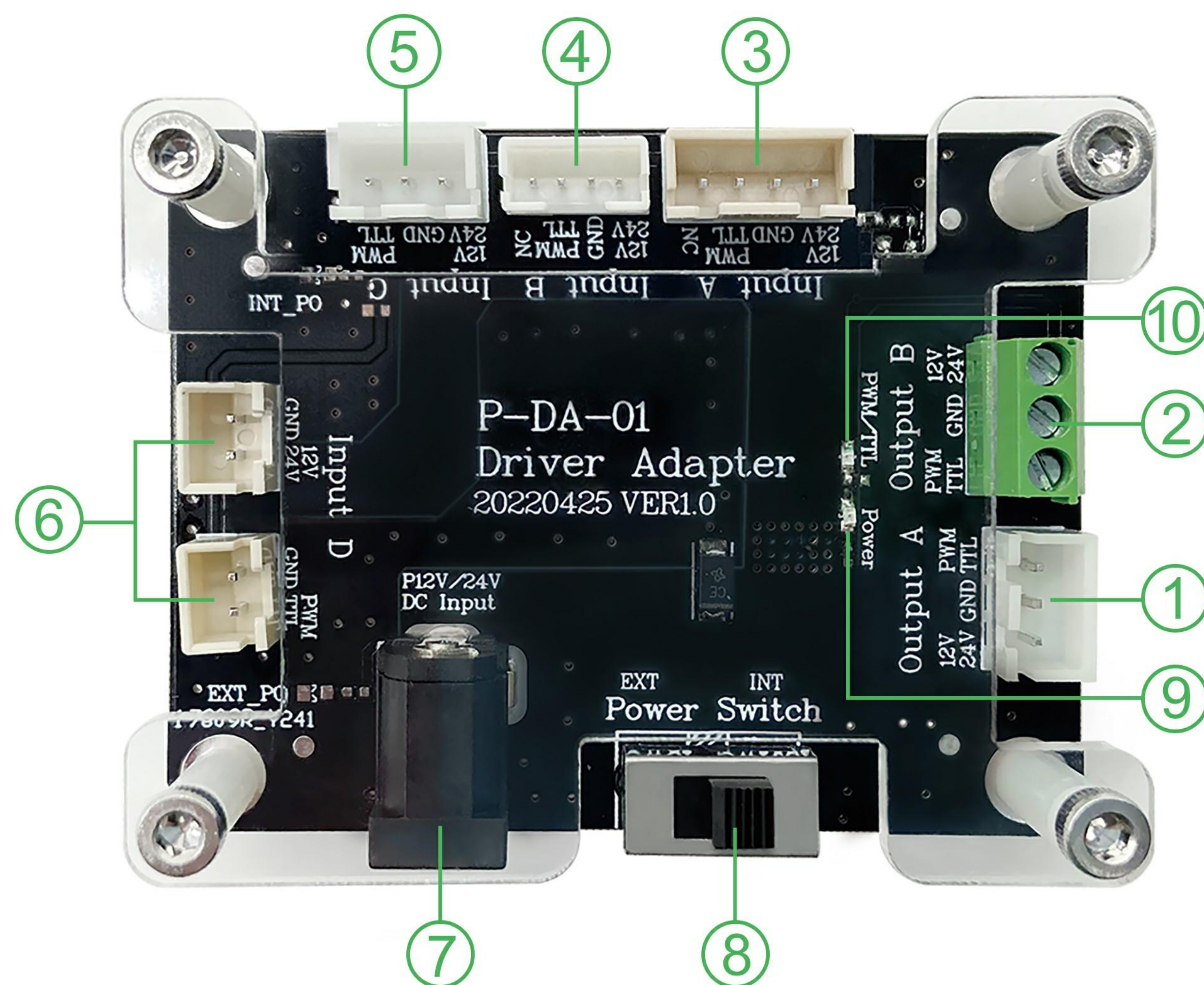
 Driver adapter (Model: P-DA-01)

① Output A: 3PIN connector	② Output B: 3PIN connector
③ Input A: 4PIN connector	④ Input B: 4PIN connector
⑤ Input C: 3PIN connector	⑥ Input D: 2PIN connector
⑦ DC Input: 12V or 24V power adapter	
⑧ Power Switch: • EXT→External power supply • INT→Internal power supply	
⑨ Power indicator: It is red when the power cable is connected correctly.	
⑩ TTL/PWM indicator: It is green when the TTL/PWM cable is connected correctly.	

Sliding plate

Multiple holes bring you widely installation compatibility.

Outline dimension (Unit: mm)

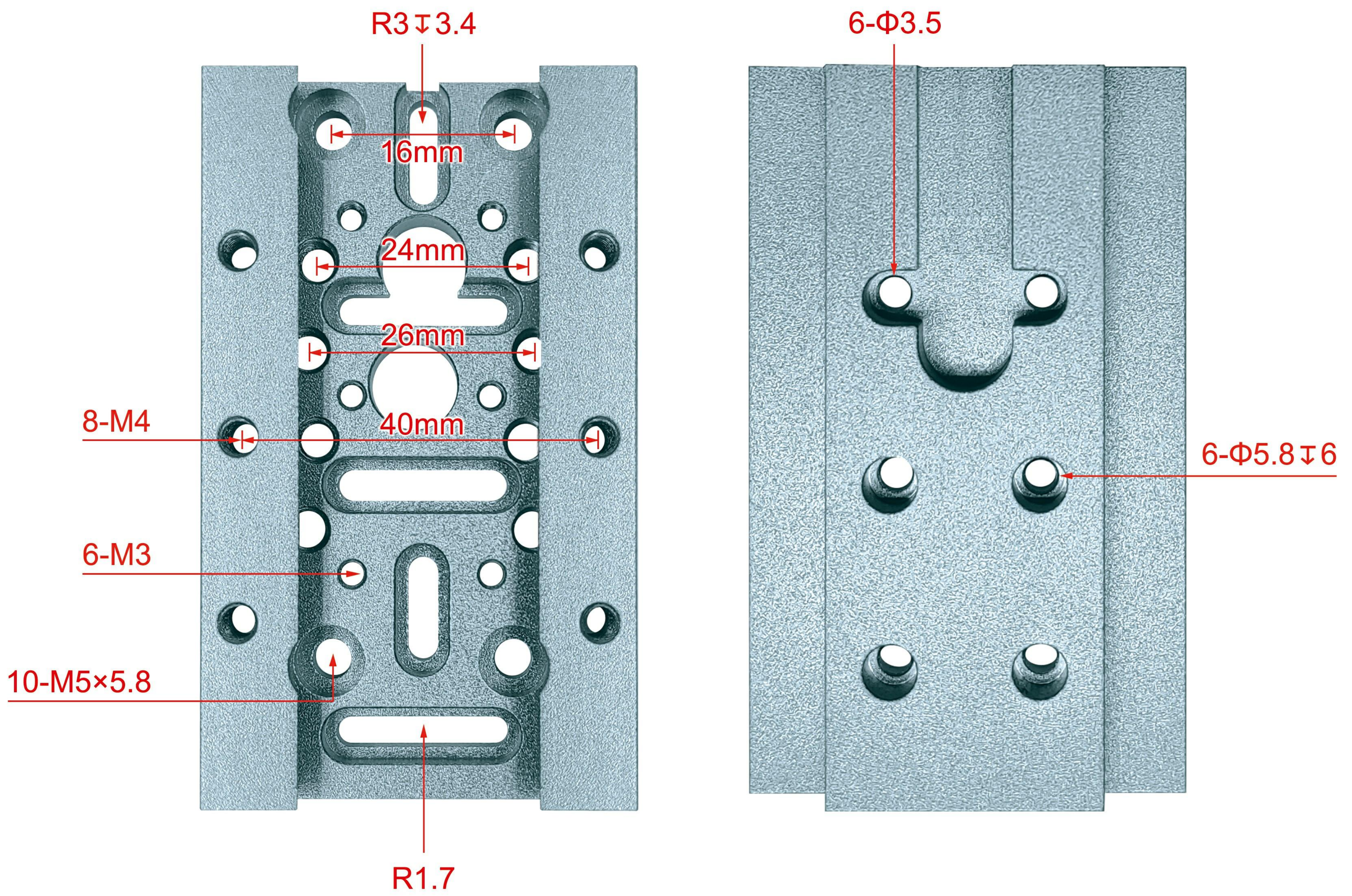

Accessories for sliding plate



M3x6 Fasten screw*4



M4x20 Fasten screw*2



2.5mm L-wrench

Installation for sliding plate

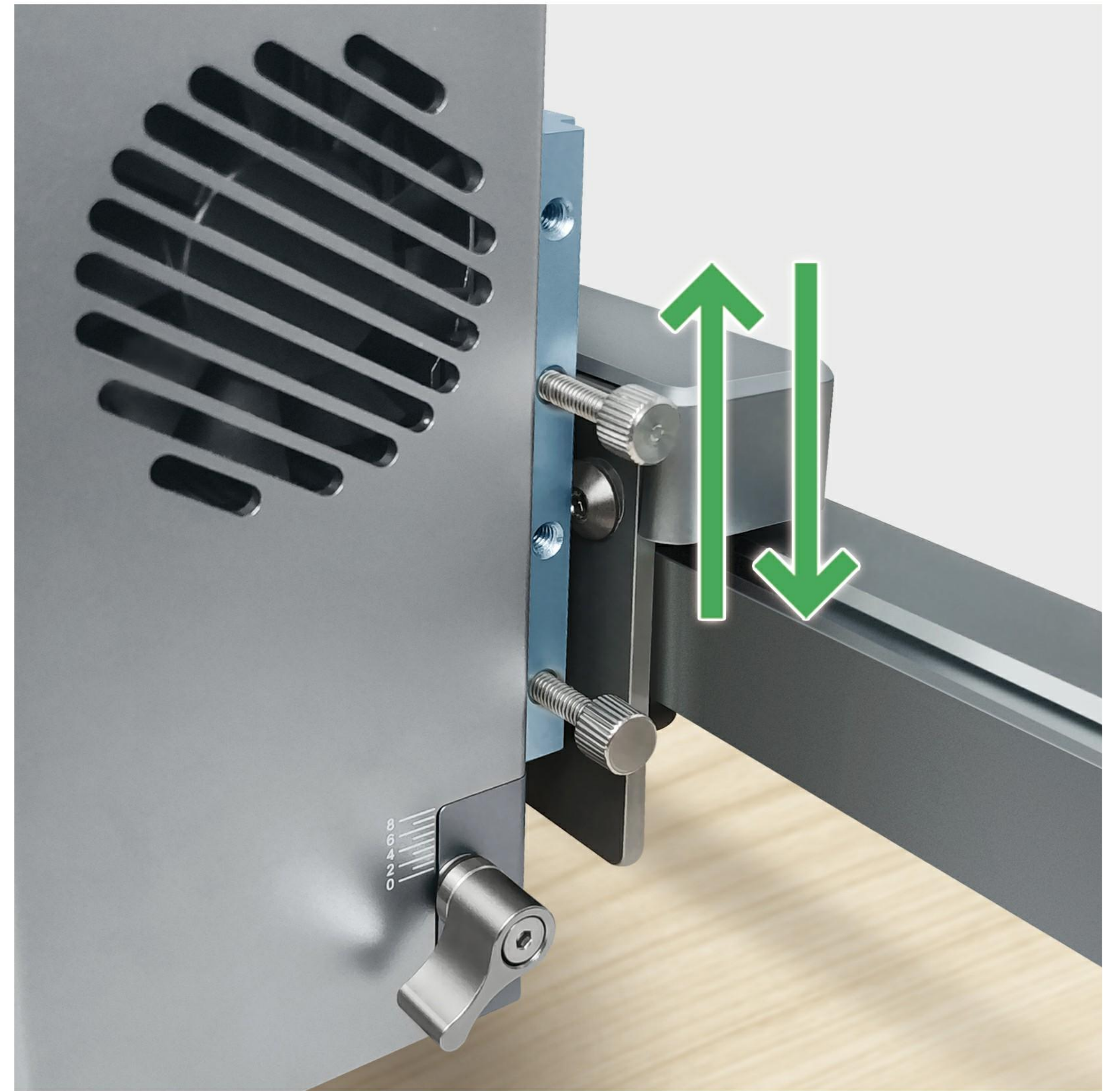
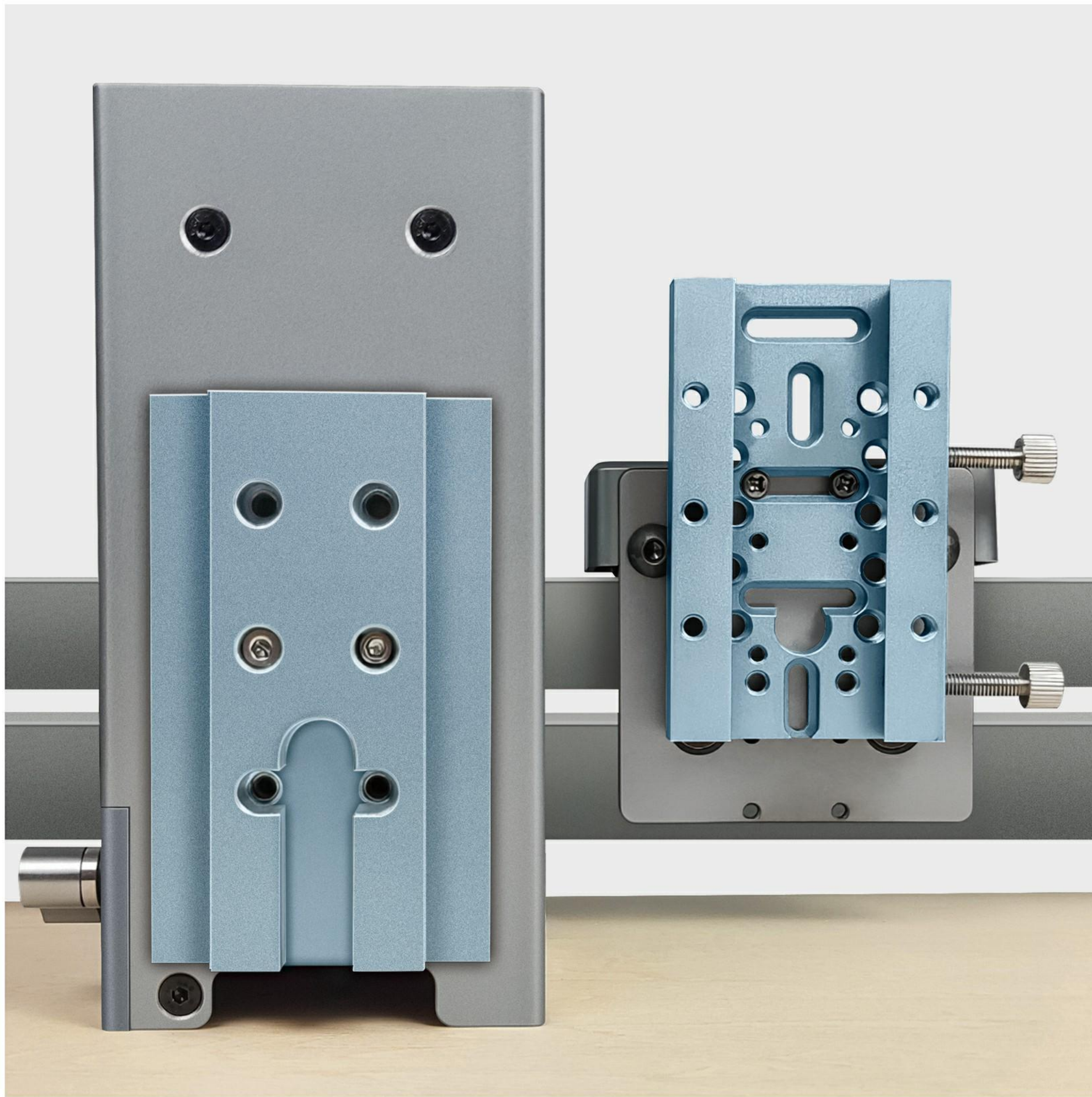

≡ PIN definition

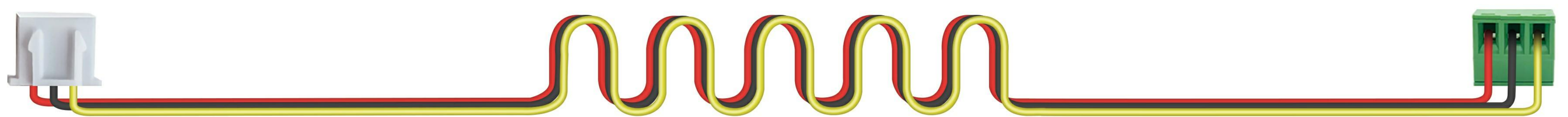

80cm Input cable

Yellow wire: PWM

Black wire: GND

Red wire: Power (24V)

3. CONNECTION DESCRIPTION

Please check whether the laser module is compatible with your engraving machine before connection.

A. Check the voltage parameter of you engraving machine.

Please ensure your engraving machine can provide at least 24V4A power supply.

B. Check the port of the main control board on your engraving machine.

Please find the PWM port, GND port and VCC port on the main board of your engraving machine. Then connect this laser module to the main board accordingly.

- “A”&“B”are both compatible.

Connect the laser module to the main board of your engraving machine directly.

Engraving machine main board

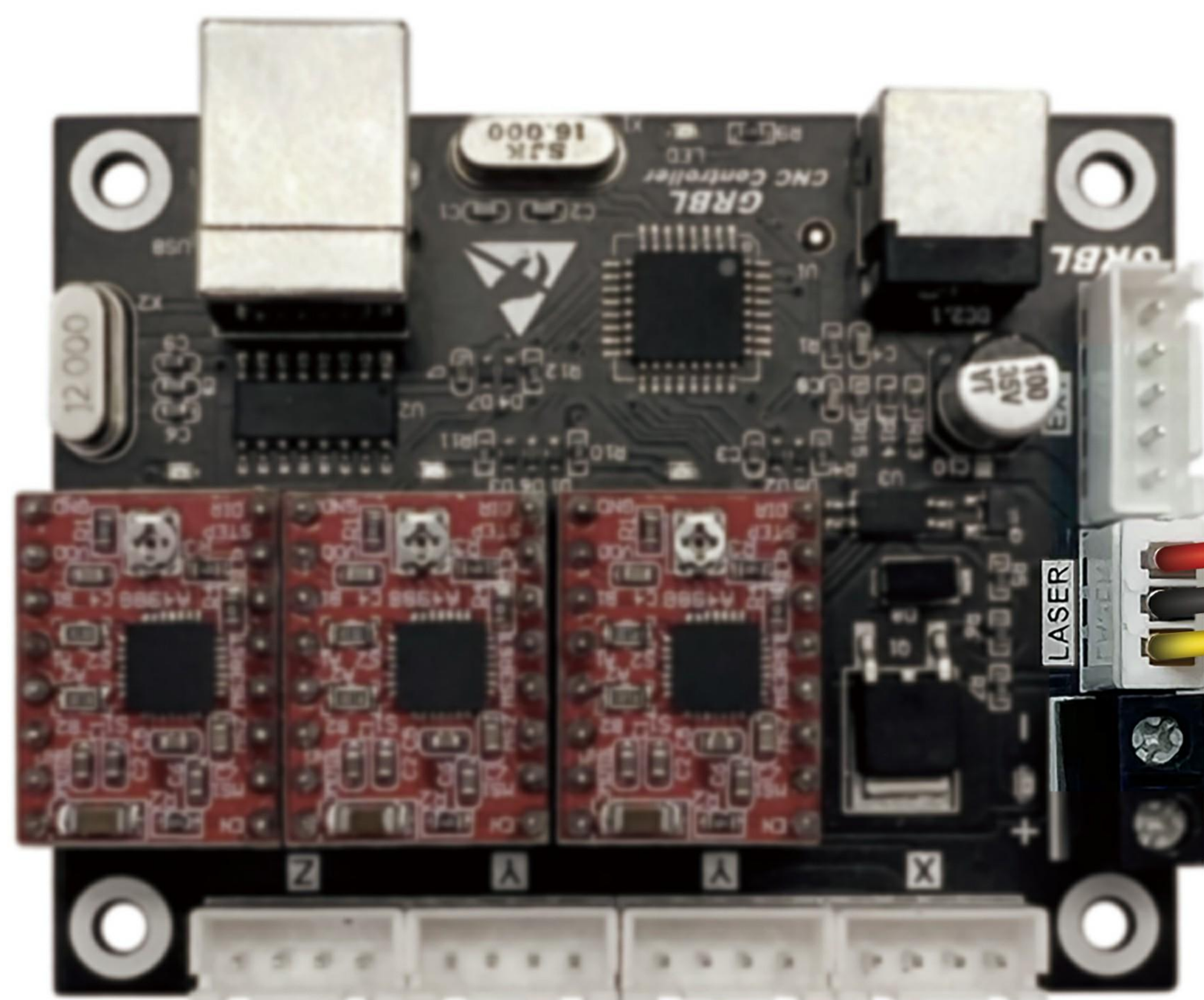

Laser module

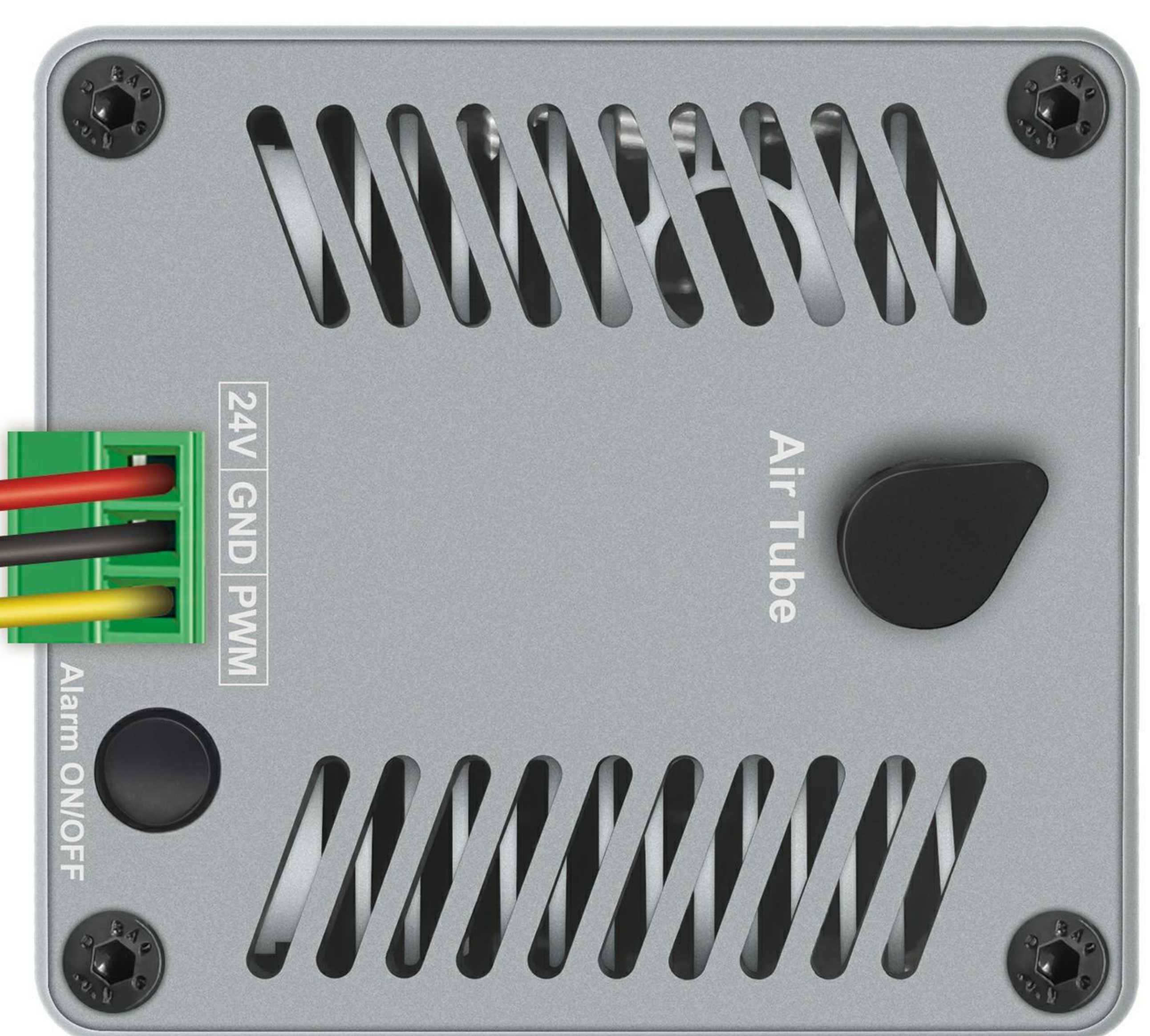

Reference picture

● Only voltage is not matched.

The voltage parameter of your machine are not matched to the module.

Laser Module	Machine	Solutions
24V	12V	Driver Adapter + 24V Power Supply
	24V	Plug and Play

- Step1** Connect the cable of your engraving machine to the corresponding input connector on P-DA-01.
- Step2** Connect the cable of the laser module to the Output A connector on P-DA-01.
- Step3** Connect the 24V power adapter to the DC Input connector on P-DA-01. Push the switch to EXT position and the power is provided by external power adapter.

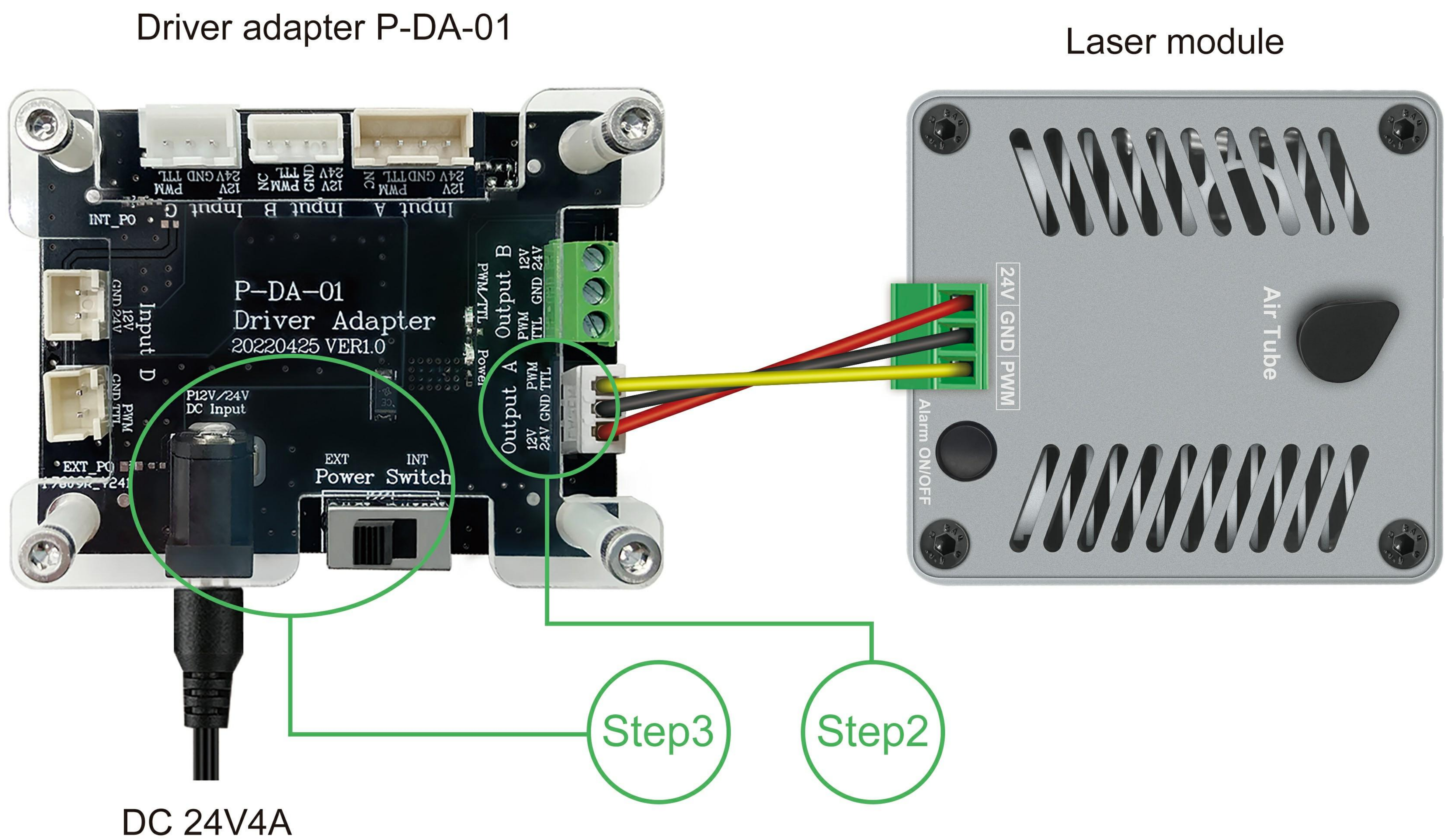

Reference picture

- Only control board pin definition is not matched.

Situation 1: The definition of connector on the engraving machine main board is not pin-to-pin.

Please rearrange the wire sequence of the cable to make each wire is well matched with the pin definition on the engraving machine main board.

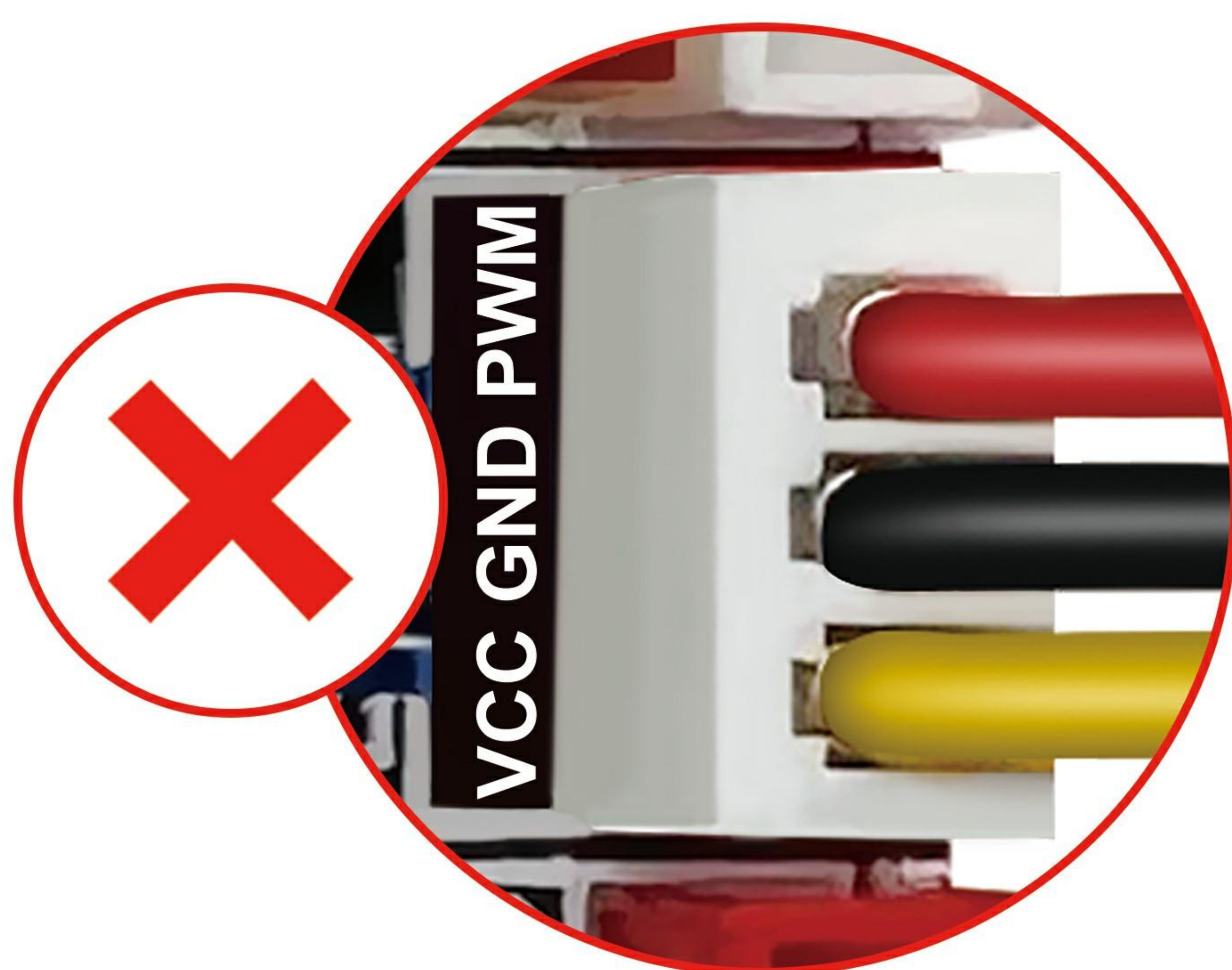

Red wire and yellow wire
connection error

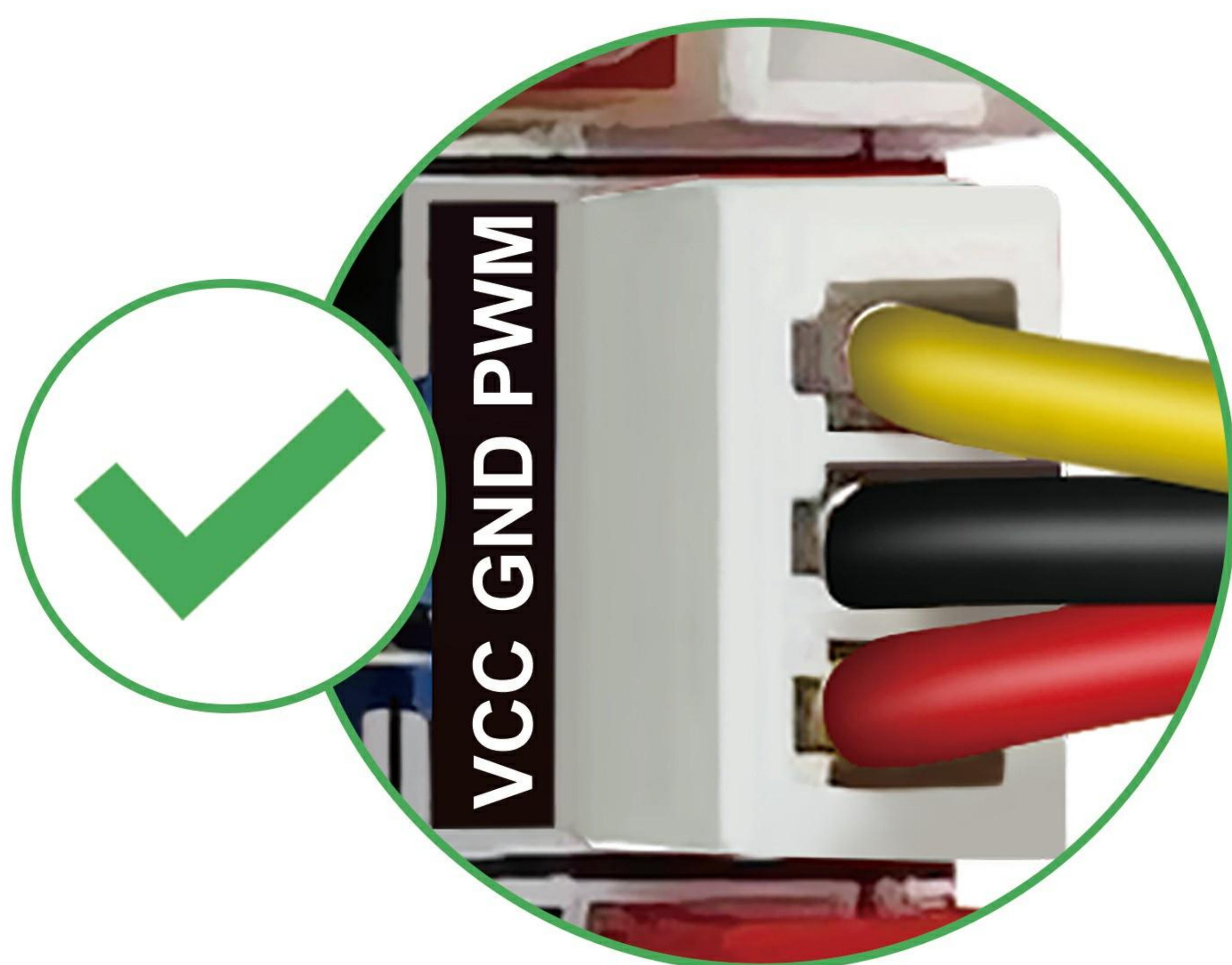

Red wire and yellow wire
connection correctly

Situation 2: Please use P-DA-01 if the main board of your engraving machine is not 3pin, such as 2pin.

Laser Module	Machine	Solutions
3PIN	2PIN	Driver Adapter
	Other pins	Driver Adapter

Step1

Connect the cable of the your engraving machine to the corresponding input connector on P-DA-01.

Step2

Connect the cable of the laser module to the Output A connector on P-DA-01.

Engraving machine main board

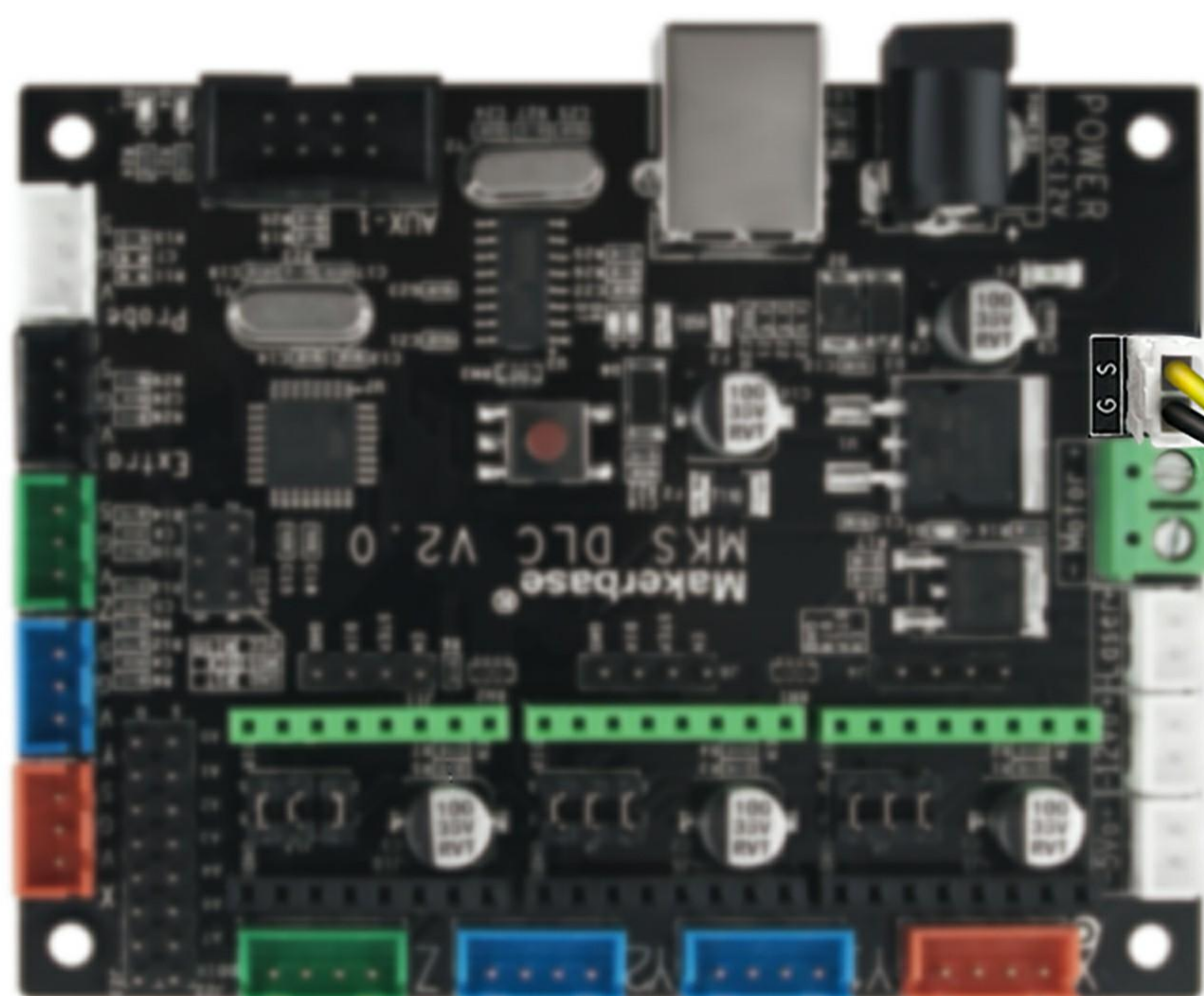

Driver adapter P-DA-01

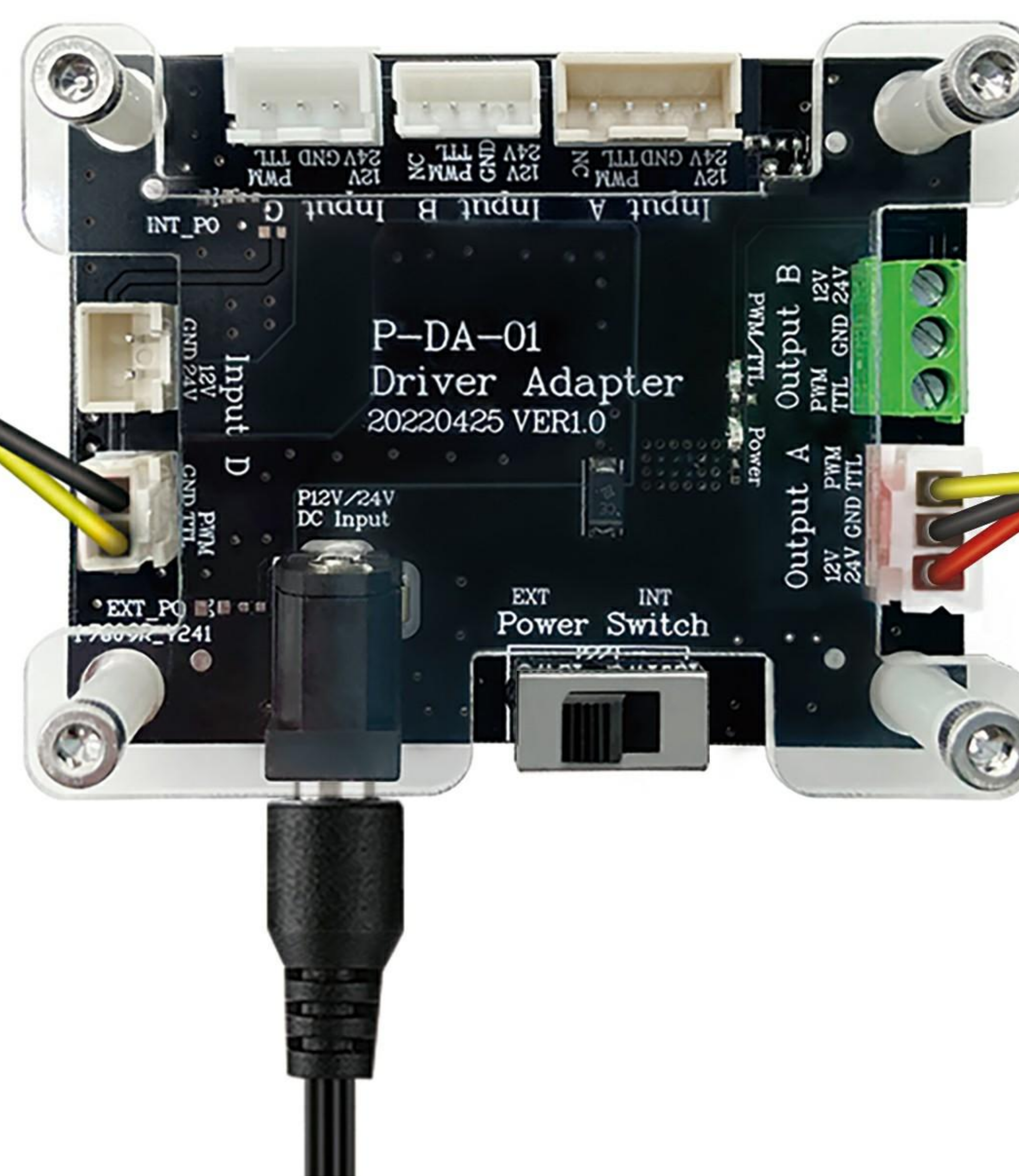

DC 24V4A

Laser module

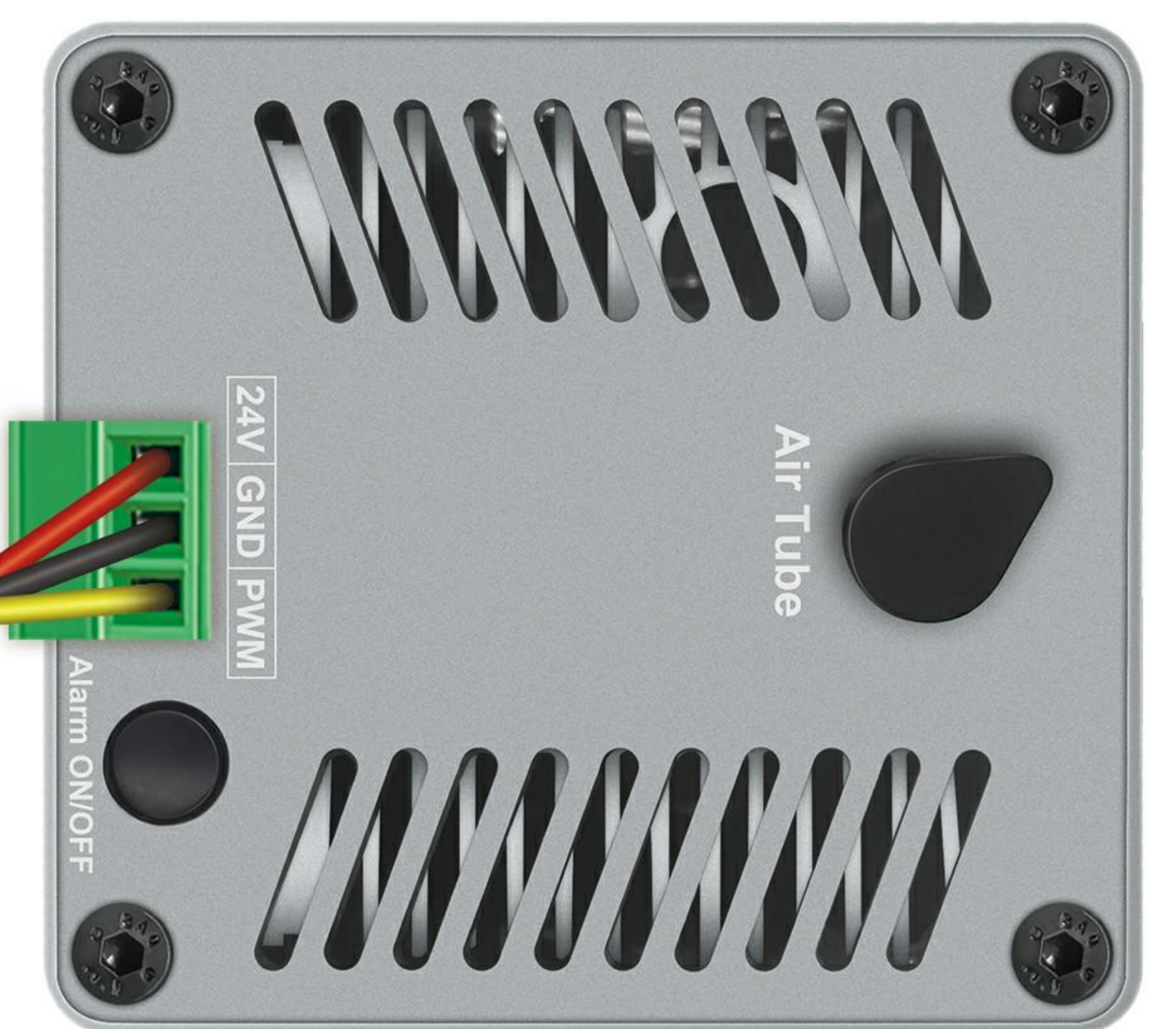

Reference picture

4. FOCUS REFERENCE SETTINGS

The focal length of the K20 laser module is 40mm.

 For cutting

Please make the focus locate lower than the cutting material surface according to the following.

Reference settings for cutting

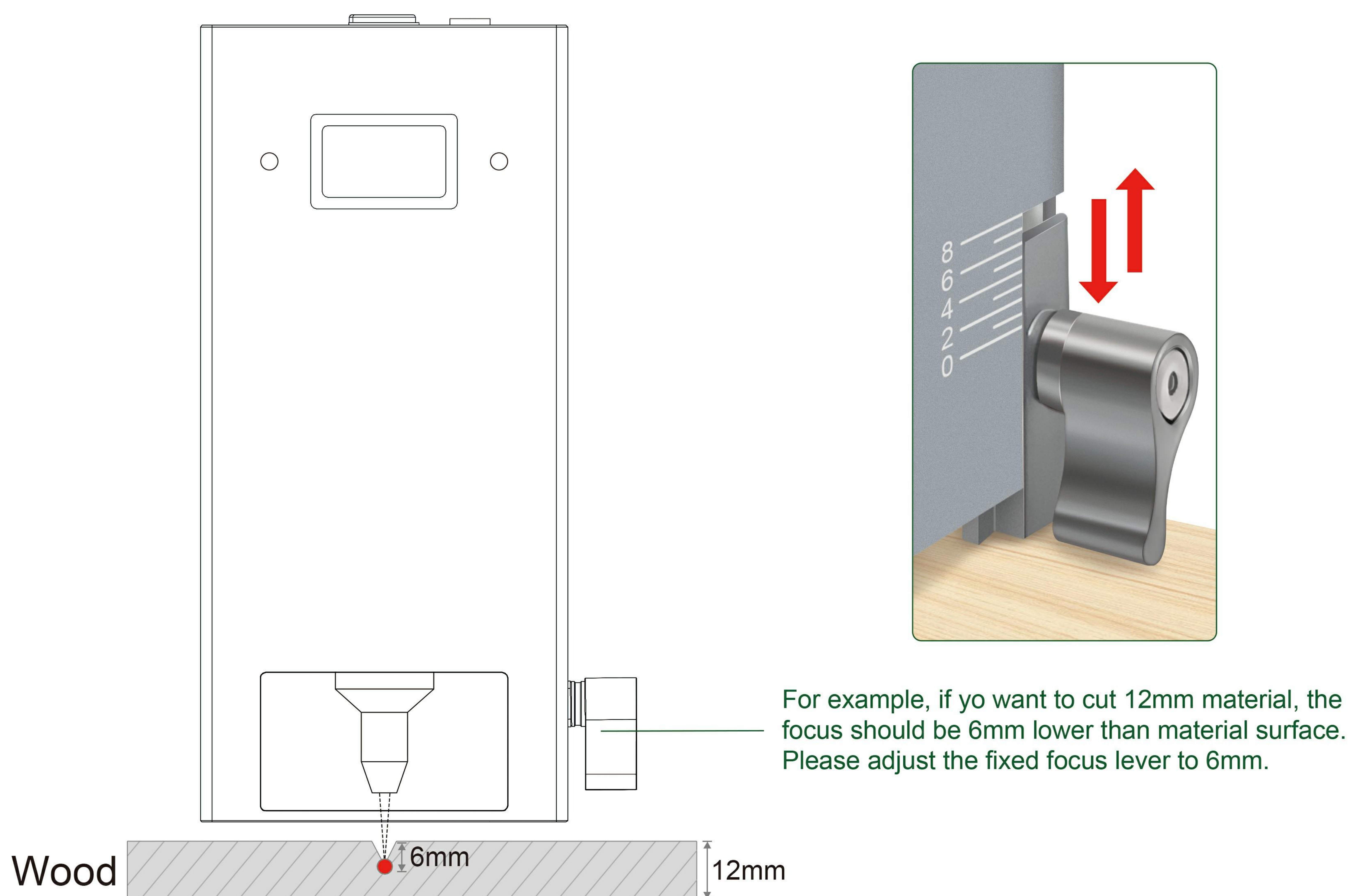

Fixed focus lever usage reference						
Material thickness	< 5mm	5mm	8mm	10mm	12mm	≥ 15mm
Fixed focus lever	0mm	2mm	4mm	5mm	6mm	7mm

 For engraving

Please make the focus locate on the engraving material surface.

Reference settings for engraving

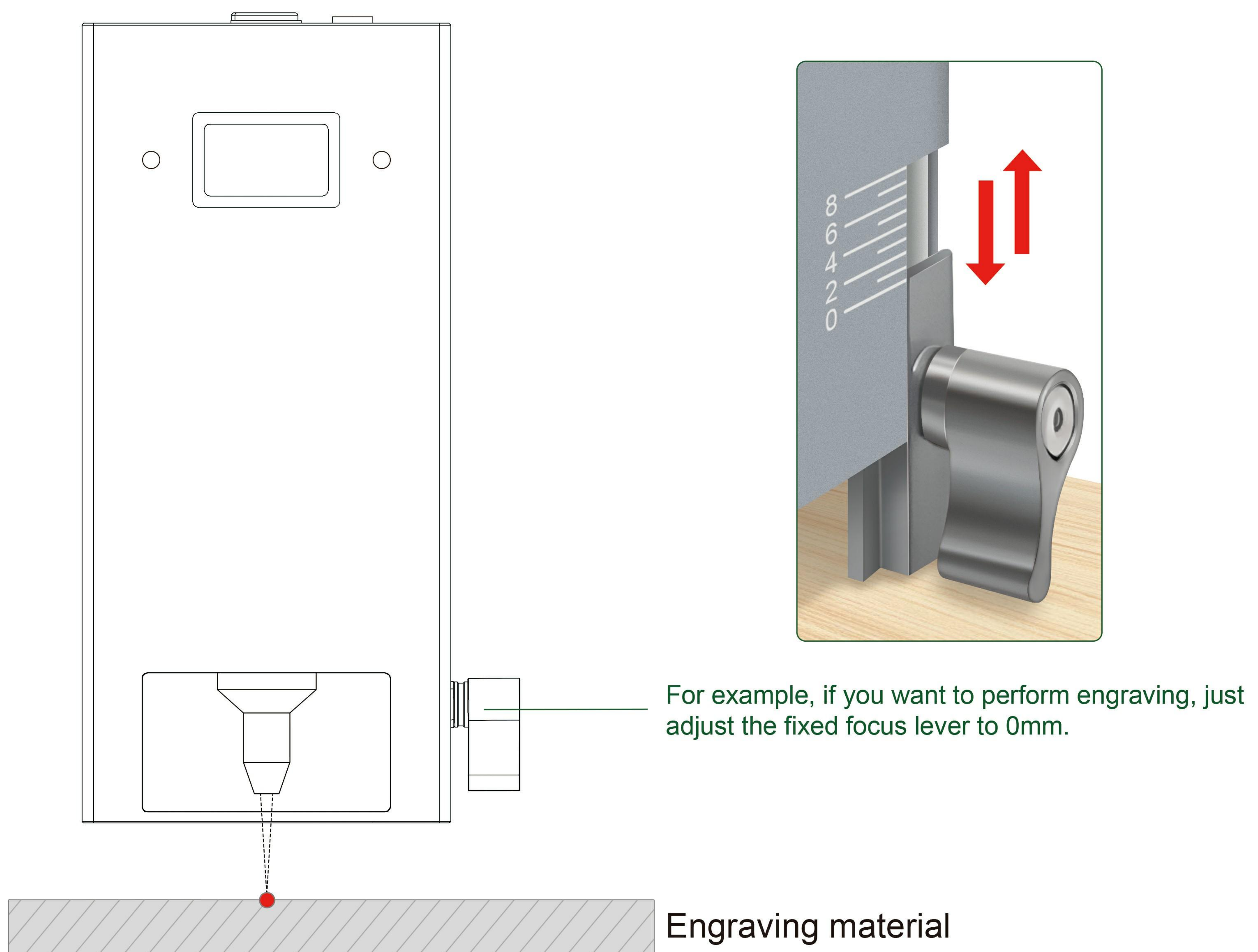

5. PRECAUTIONS



Laser may cause damage to your skin. Please do not expose your skin directly to the laser.



Please wear laser goggles to protect your eyes when you use this laser module.



Please ensure that the air pump is turned on before you start cutting. If not, the smoke will contaminate the lens.



This laser module doesn't support hot plug, hot plug may cause damage to the laser module.

6. MAINTENANCE



When the laser module is not used for a long time, please ensure that the lens is not polluted by dust.



When you replace the air nozzle, please ensure that your operation will not pollute the lens. Finger prints or dust on the lens will weaken the output power of the laser module, or even damage the lens.



When you find the cutting ability decreases, the lens might be not clean. Please use a clean alcohol swab to clean it according to the following figure.

* For more information about maintenance, please contact us at lasertree@micost-optotech.com.

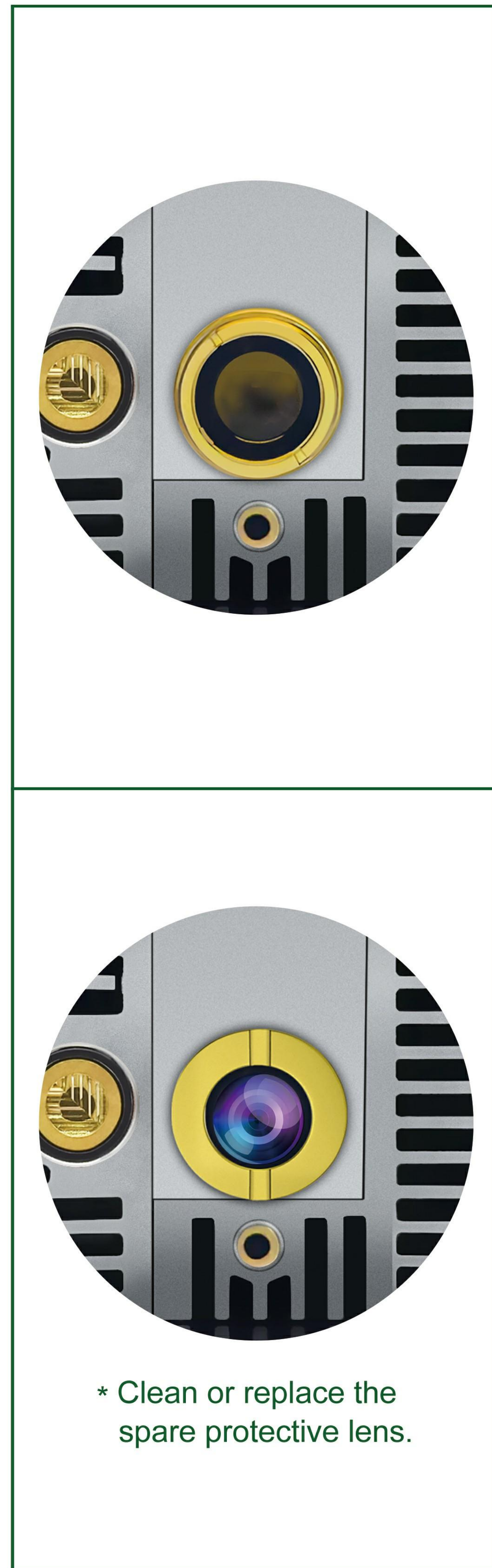



LASER TREE

Enjoy pleasure of DIY

CE FCC RoHS



MADE IN CHINA