

MONTAGEANLEITUNG / ASSEMBLY INSTRUCTION / INSTRUCTION DE MONTAGE  
MONTAGE INSTRUCTIE / (スツル) の組み立て方

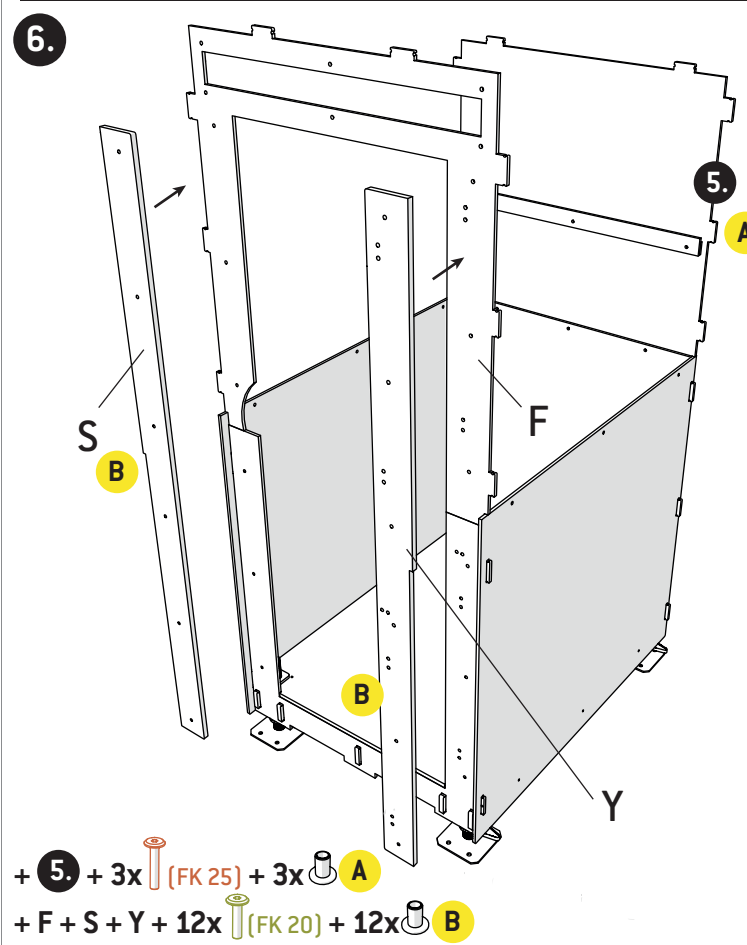

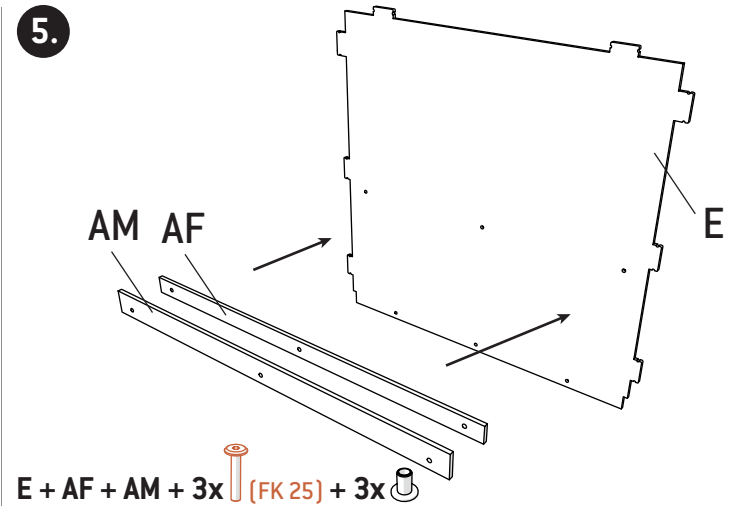

D + AE + AG + 3x (FK 25) + 3x

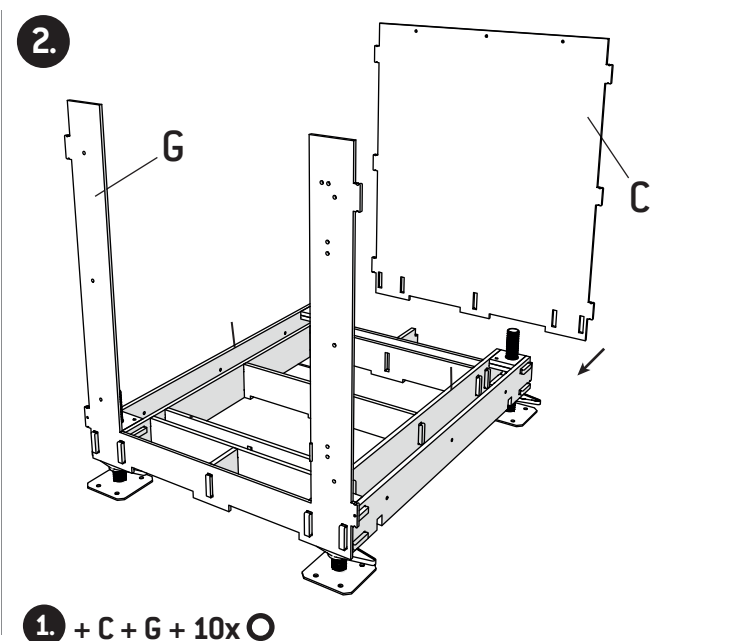
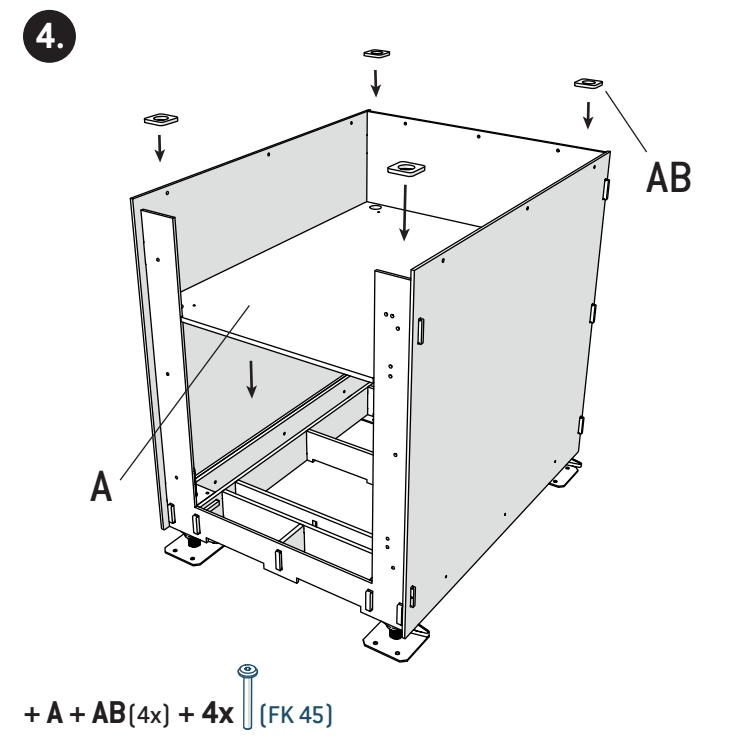
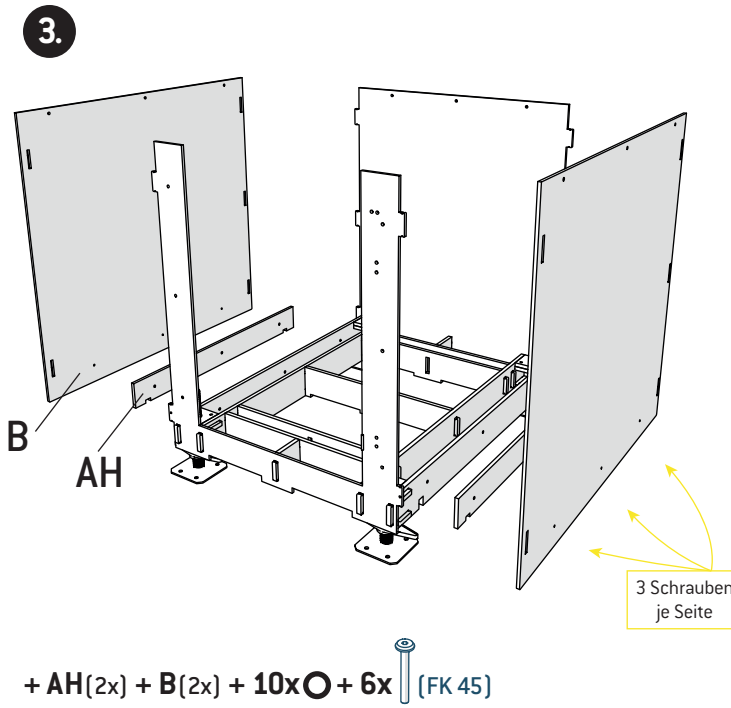
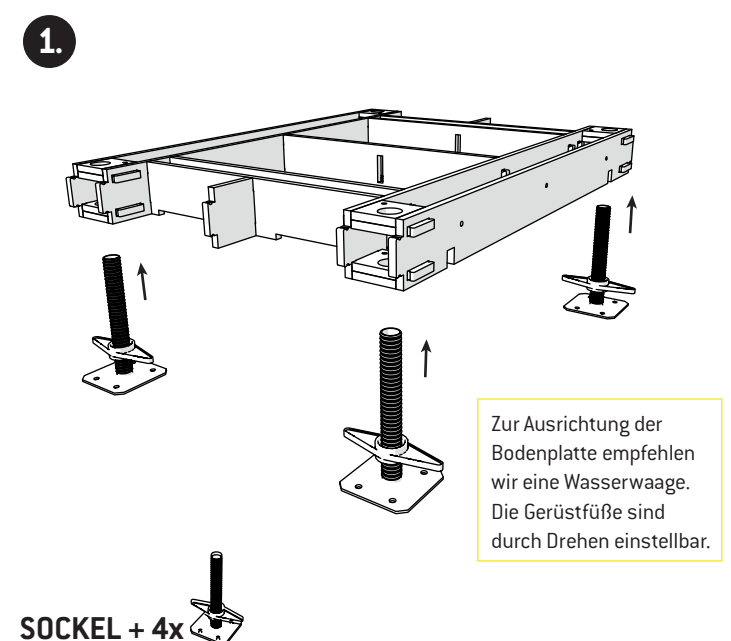
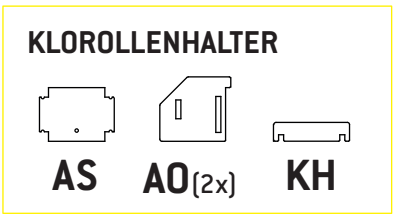
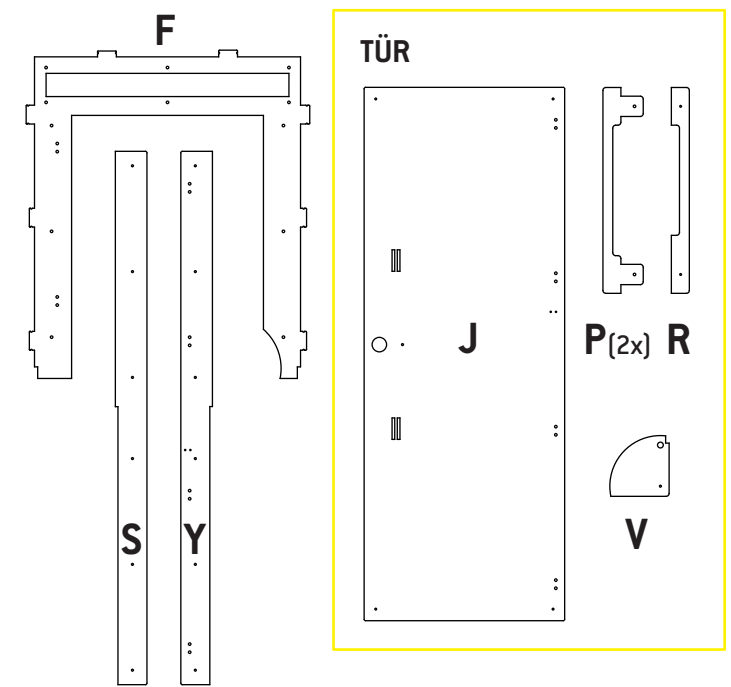
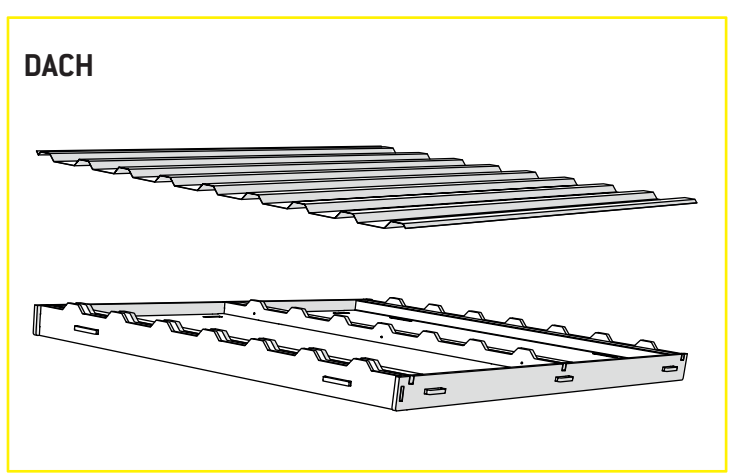
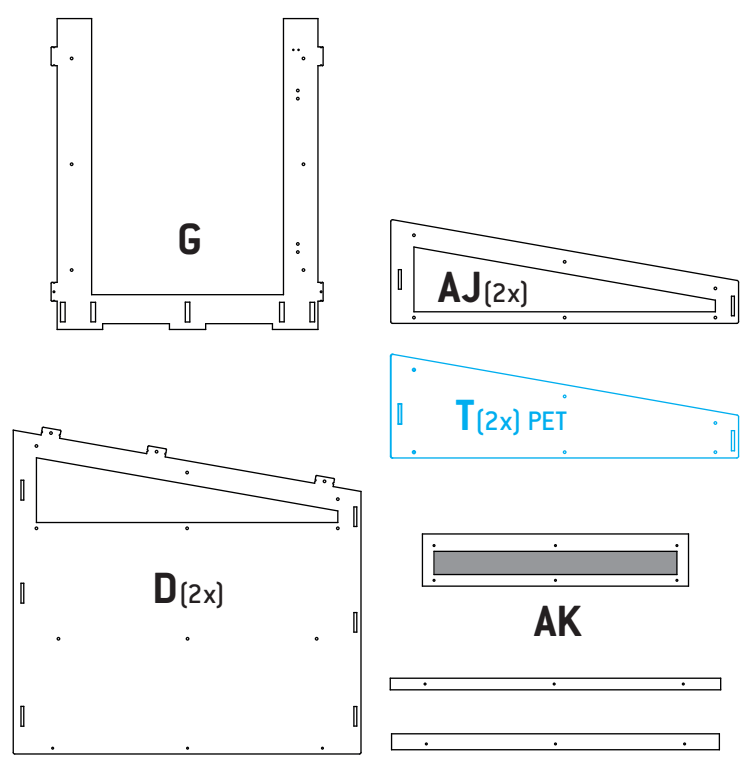
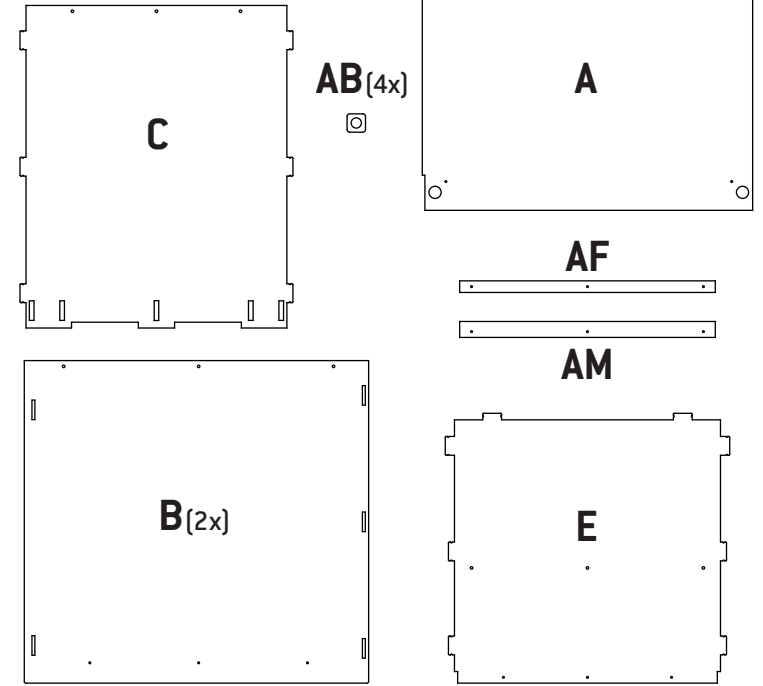
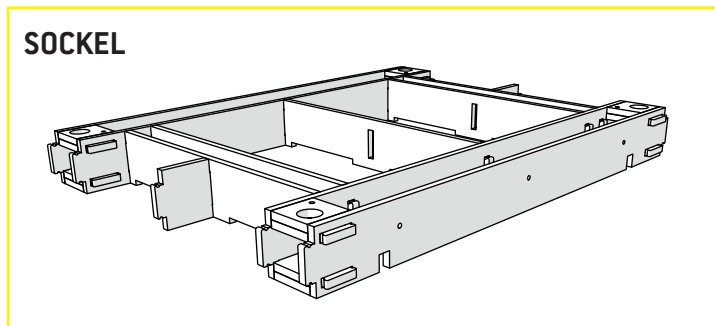
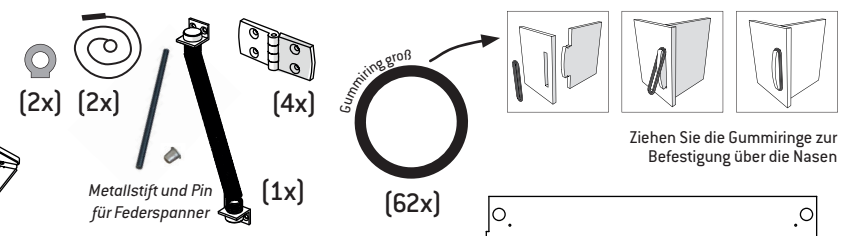
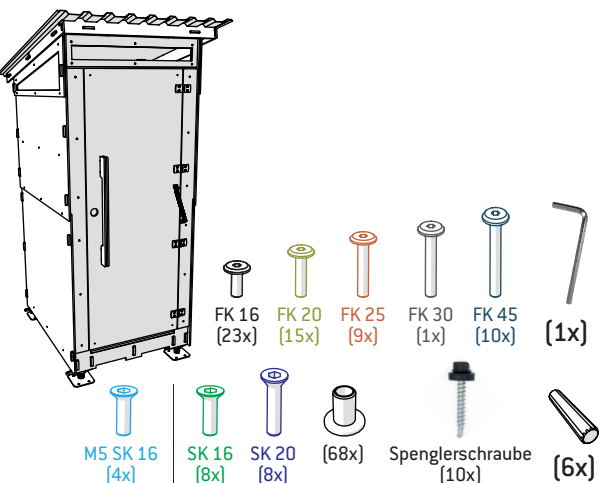
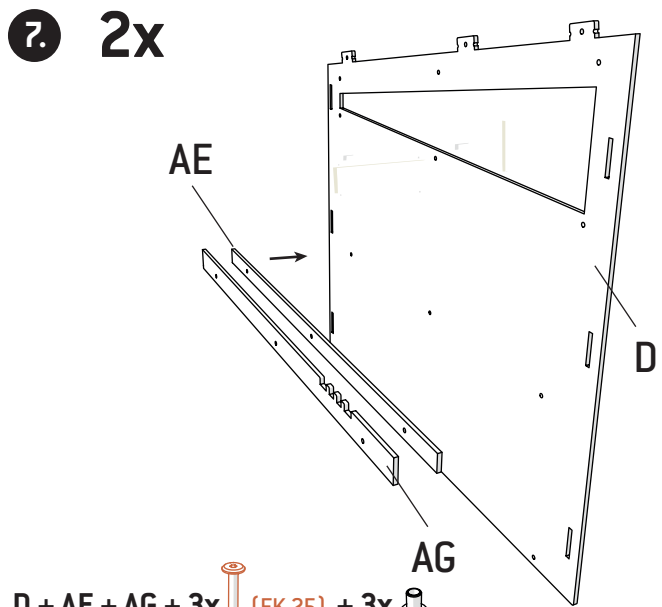
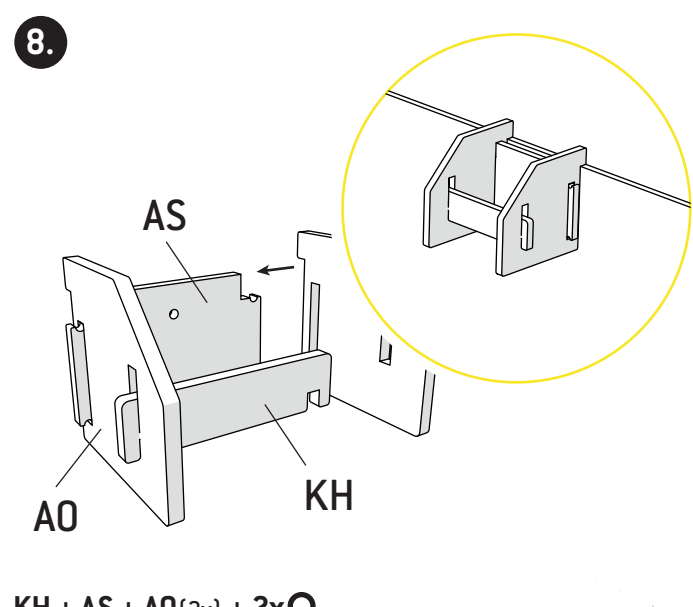

KH + AS + AO(2x) + 2x

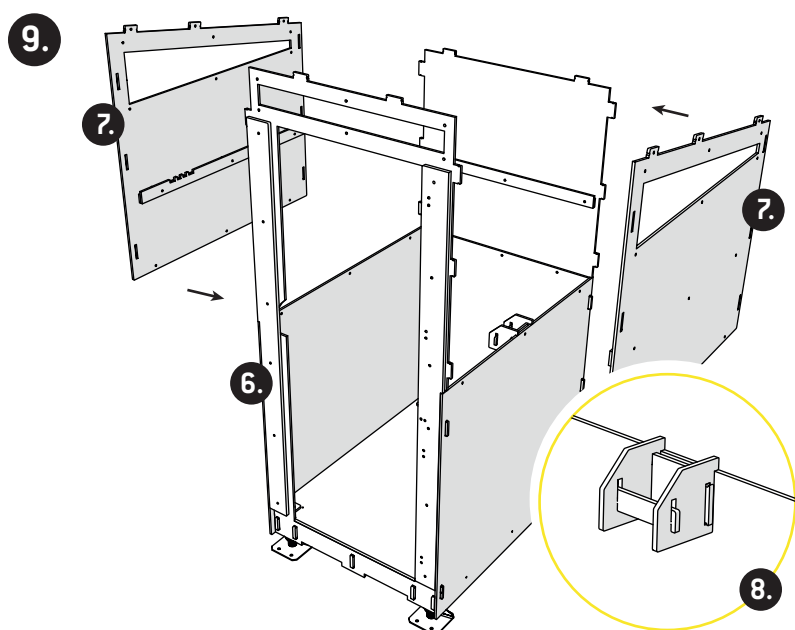

6. + 7. + 12x + 5x (FK 16) + 5x   
+ 8. + 1x (FK 30) + 1x

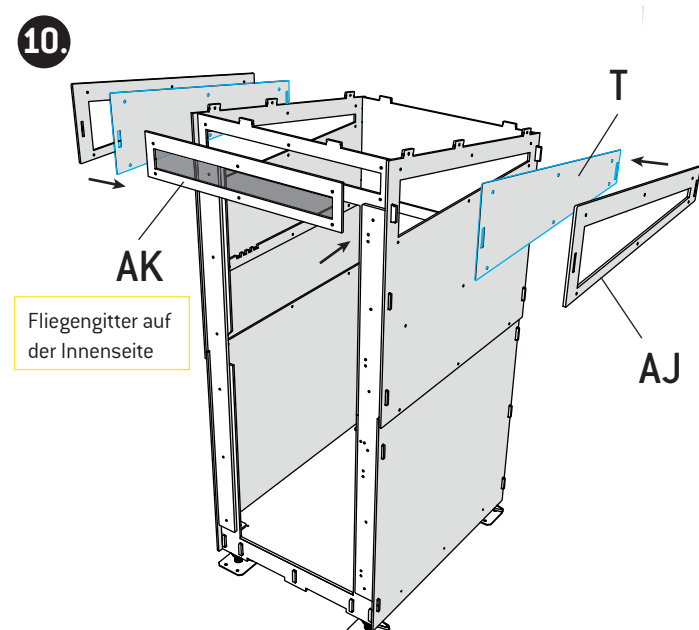

+ AK + T(2x) + AJ(2x) + 4x + 18x (FK 16) + 16x

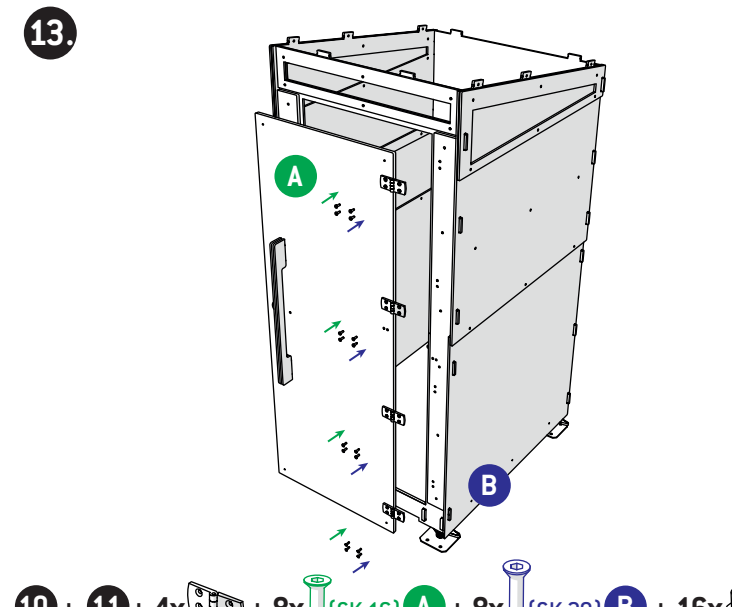

+ 10. + 11. + 4x + 8x (SK 16) A + 8x (SK 20) B + 16x

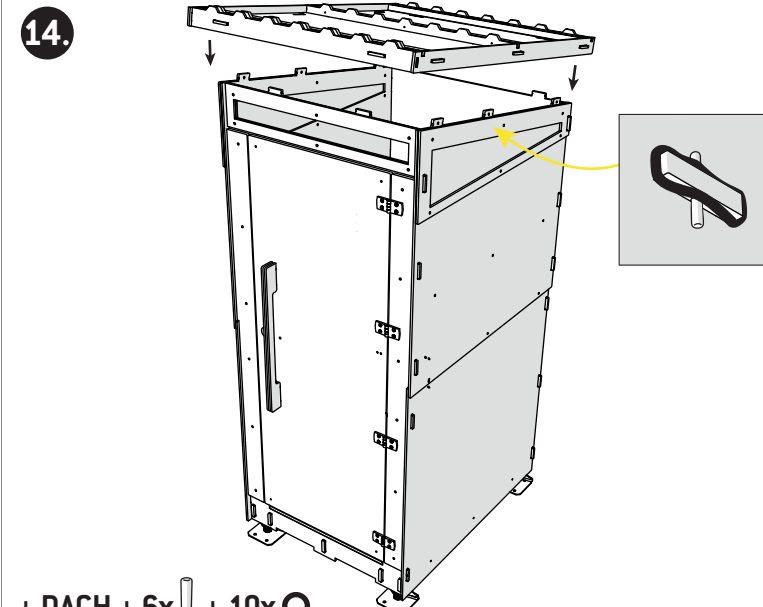

+ DACH + 6x + 10x



+ TRAPEZBLECH + 10x

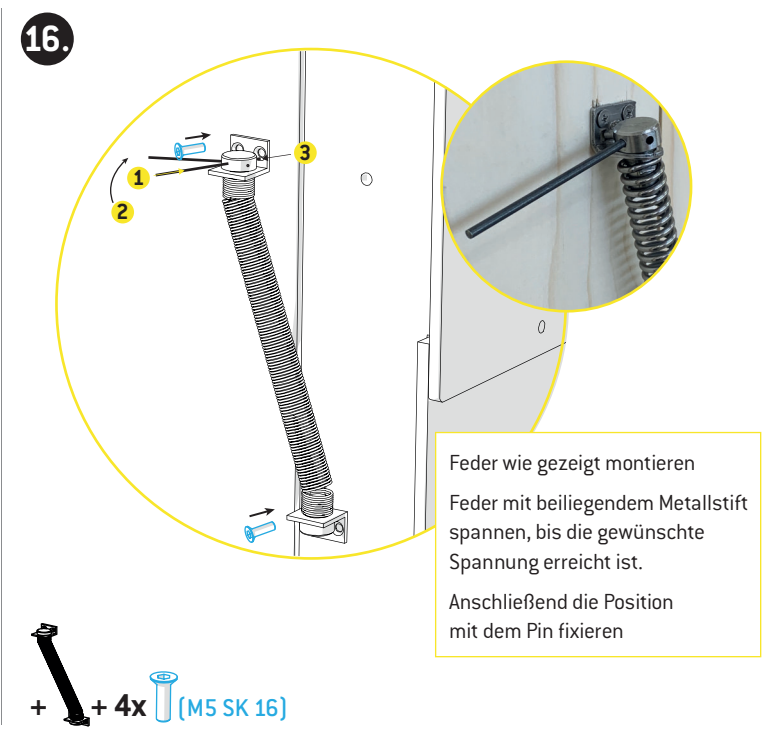

+ 16. + 4x (M5 SK 16)

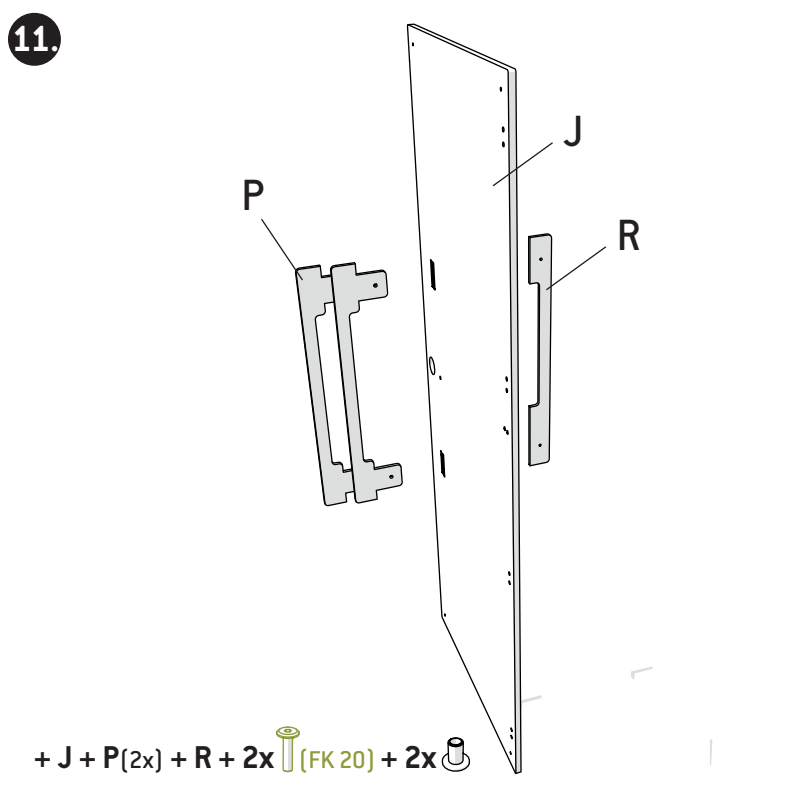

+ J + P(2x) + R + 2x (FK 20) + 2x

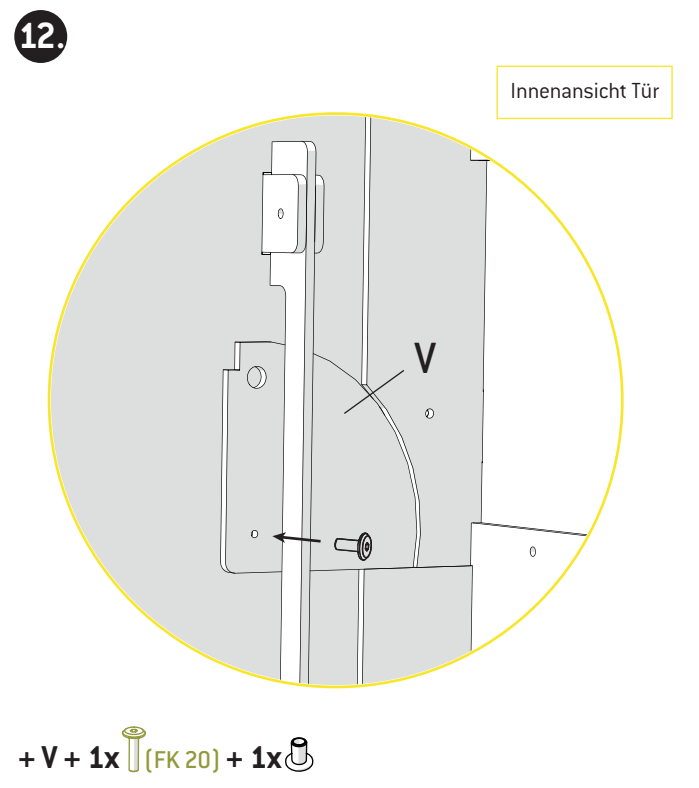

+ V + 1x (FK 20) + 1x

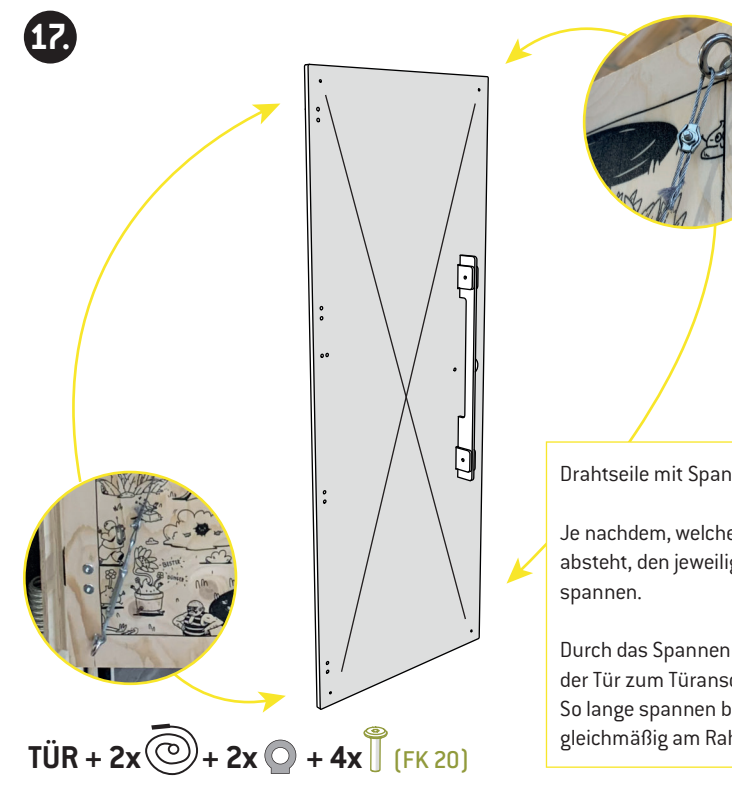

TÜR + 2x + 2x + 4x (FK 20)

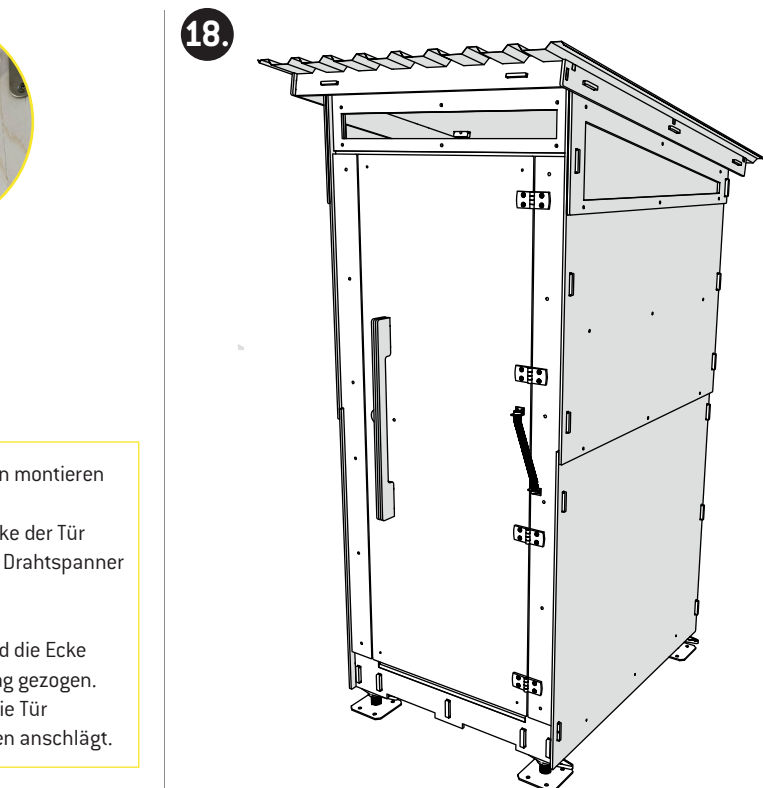

+ 18. + 2x + 2x