

**MIRKA**

## Mirka® ROS2

200 mm (8")

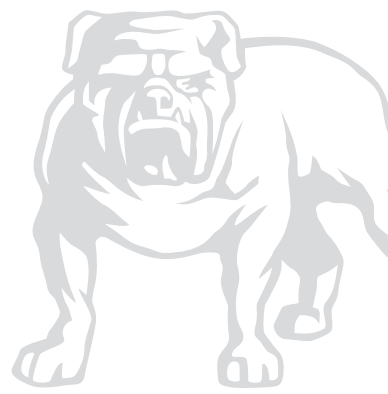



# Mirka® ROS2

200 mm (8")

<b>ar</b>	لي غشش لال ااداش رإ	4-7
<b>bg</b>	Инструкция за експлоатация	8-11
<b>cs</b>	Návod k obsluze	12-15
<b>da</b>	Brugsanvisning	16-19
<b>de</b>	Bedienungsanleitung	20-23
<b>el</b>	Οδηγίες χρήσης	24-27
<b>en</b>	Operating instructions	28-31
<b>es</b>	Instrucciones de manejo	32-35
<b>et</b>	Kasutusjuhised	36-39
<b>fi</b>	Käyttöohjeet	40-43
<b>fr</b>	Instructions d'utilisation	44-47
<b>hr</b>	Upute o radu	48-51
<b>hu</b>	Kezelési útmutató	52-55
<b>it</b>	Istruzioni per l'uso	56-59
<b>ja</b>	取扱説明書	60-63
<b>ko</b>	사용 지침	64-67
<b>lt</b>	Naudojimo instrukcijos	68-71
<b>lv</b>	Lietošanas instrukcija	72-75
<b>nl</b>	Gebruiksaanwijzing	76-79
<b>no</b>	Bruksanvisning	80-83
<b>pl</b>	Instrukcje dot. użytkowania	84-87
<b>pt</b>	Instruções de operação	88-91
<b>ro</b>	Instrucţiuni de operare	92-95
<b>ru</b>	Руководство по эксплуатации	96-99
<b>sl</b>	Navodila za uporabo	100-103
<b>sr</b>	Uputstvo za rad	104-107
<b>sv</b>	Bruksanvisning	108-111
<b>tr</b>	İşletim Talimatları	112-115
<b>zh</b>	操作说明	116-119

# Parts Page

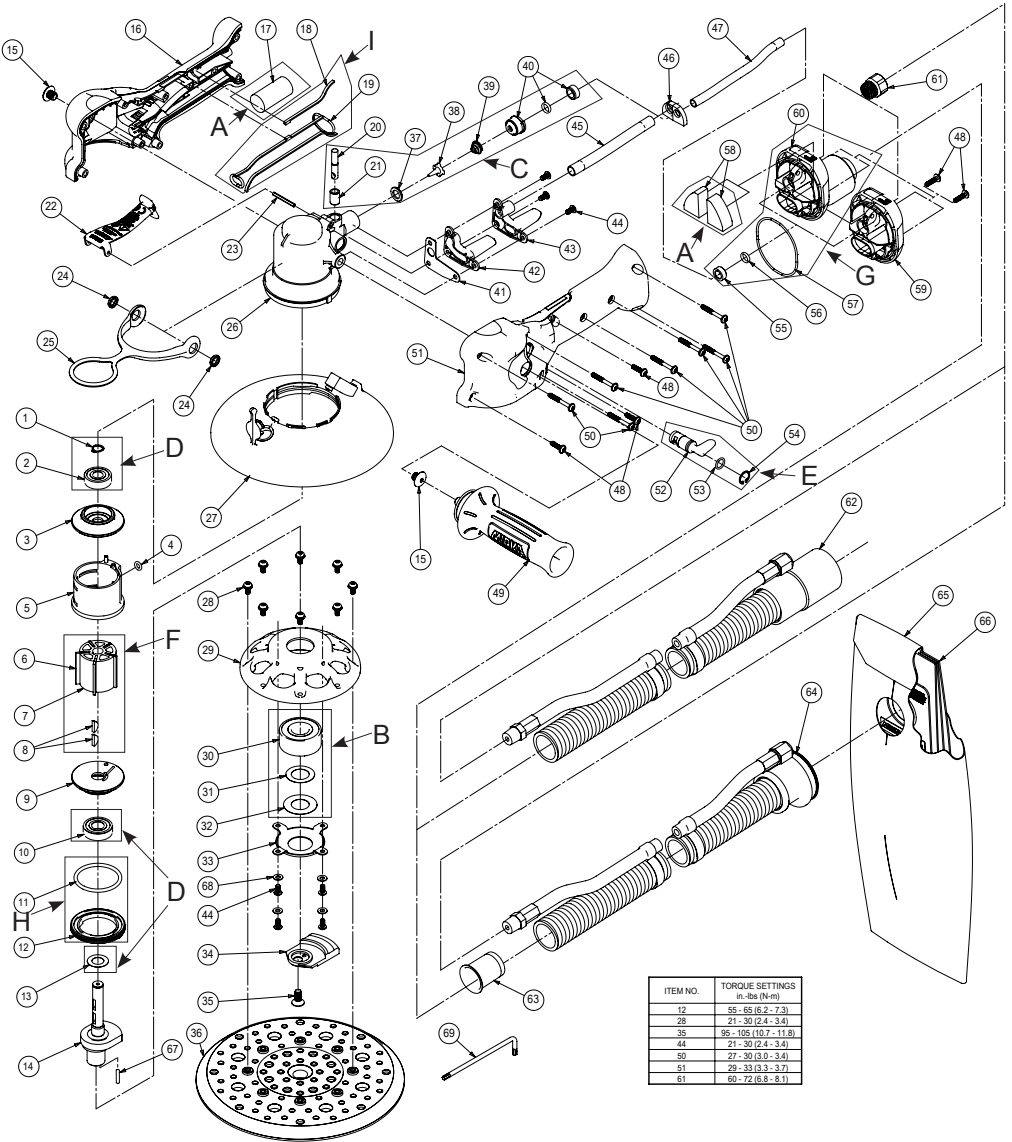

ITEM NO.	TORQUE SETTINGS in-lbs (N-m)
12	55-65 (2.7-3)
28	21-30 (2.4-3.4)
35	95-105 (10.7-11.8)
44	21-30 (2.4-3.4)
50	27-30 (3.0-3.4)
51	29-33 (3.3-3.7)
61	60-72 (6.8-8.1)

## Parts List

Item No.	Part No.	Description	Qty.
1	MPA0040	EXTERNAL RETAINING RING	1
2	MPA0021	BEARING	1
3	MPB0017	REAR ENDPLATE	1
4	MPA0042	O-RING	1
5	MPA0441	CYLINDER ASSEMBLY	1
6	MPA0445	VANE	5
7	MPB0118	ROTOR	1
8	MPA0041	KEY	2
9	MPB0016	FRONT ENDPLATE	1
10	MPA0019	BEARING	1
11	MPA0045	O-RING	1
12	MPA0001	LOCK RING	1
13	MPA2541	FRONT BEARING DUST SHIELD	1
14	MPB0444	MOTOR SHAFT	1
15	MPA1711	THREADED PLUG	2
16	MPB0393	RH HOUSING	1
17	MPA0032	MUFFLER INSERT	1
18	MPA1218	TOP HOUSING SEAL	1
19	MPB0290	MOTOR HOUSING SEAL	1
20	MPA0655	VALVE STEM ASSEMBLY	1
21	MPA0015	VALVE SLEEVE	1
22	MPA2588	5.0 mm (3/16 in.) ORBIT SAFETY LEVER ASSEMBLY	1
23	MPA0004	CYLINDER SPRING PIN	1
24	MPA1865	SPACER RING	2
25	MPB0420	HANGER	1
26	MPB0356	MOTOR HOUSING	1
27	MPD0050	8 in. (200mm) SHROUD	1
28	MPA2379	SCREW	8
29	MPA1902	8 in. ROS PAD BACKING	1
30	MPA2559	DOUBLE ROW BEARING	1
31	MPA2560	SPACER	1
32	MPA2581	SPINDLE BEARING DUST SHIELD	1
33	MPA1875	BELLEVILLE RETAINER	1
34	MPA1980	BALANCER	1
35	MPA0078	SCREW	1
36	NA	8 in. PAD	1
37	MPA0009	VALVE SEAT	1
38	MPA0007	VALVE	1
39	MPA0014	VALVE SPRING	1
40	MPA0730	AIRLINE SEAL ASSEMBLY	1
41	MPA0500	EXHAUST GASKET	1
42	MPB0181	DB EXHAUST NOZZLE (DB Machines)	1
43	MPB0182	NV/CV EXHAUST NOZZLE (NV & CV Machines)	1
44	MPA0664	SCREW	7
45	MPA0517	EXHAUST TUBING (NV & CV Machines)	1
46	MPA0516	TUBING CLAMP (NV & CV Machines)	1
47	MPA0511	INLET TUBING	1
48	MPA1398	SCREW	5
49	MPA1981	SIDE HANDLE - Mirka	1
50	MPA1430	SCREW	7
51	MPB0394	LH HOUSING	1
52	MPB0183	SPEED CONTROL	1
53	MPA0043	O-RING	1
54	MPA0039	INTERNAL RETAINING RING	1
55	MPA0510	INLET CAPTIVE RING	1
56	MPA0509	O-RING	1
57	MPA0628	O-RING (NV & CV Machines)	1
58	MPA0776	MUFFLER (NV & CV Machines)	2
59	MPA0731	INLET/EXHAUST END CAP ASSEMBLY (NV Machines)	1
60	MPA1294	INLET/EXHAUST END CAP ASSEMBLY (DB & CV Machines)	1
61	MPA0013	INLET BUSHING ASSEMBLY	1
62	MPA0392	Ø 28 mm (1 in.) VACUUM HOSE TO Ø 28 mm (1 in.) x 38 mm (1 1/2 in.) ADAPTOR COUPLING & AIRLINE ASSEMBLY (CV Machines)	1
63	MPA0623	Ø 28 mm (1 in.) HOSE SEAL (DB Machines)	1
64	MPA0412	Ø 28 mm (1 in.) VACUUM HOSE TO DOUBLE BAG FITTING AND AIRLINE ASSEMBLY (DB Machines)	1
65	MPA0658	VACUUM BAG (DB Machines)	1
66	MPA0465	10 PACK OF VACUUM BAG INSERTS (DB Machines)	1
67	MPA0123	GEAR SHAFT	1
68	MPA0076	M4 WASHER	4
69	MPA2665	T-20 TORX WRENCH	1

# Sander Spare Parts Kits

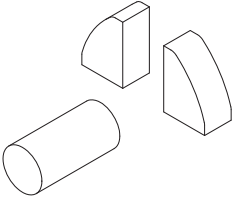

**A** MPA2214 Muffer Kit  
Code: 8994026011

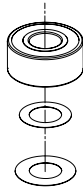

**B** MPA2625 Spindle Bearing Kit  
Code: 8994823011

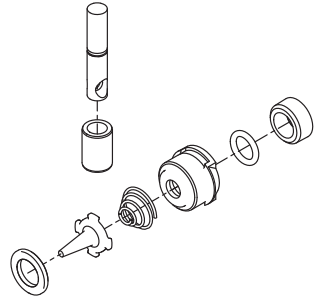

**C** MPA2216 Air Inlet Kit  
Code: 8994024011

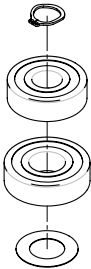

**D** MPA0799 Endplate Bearing Kit  
Code: 8993019811



**E** MPA2218 Speed Valve Kit  
Code: 8994025511

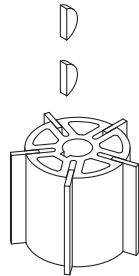

**F** MPA2220; Rotor Vanes and Key Kit  
Code: 8994020611

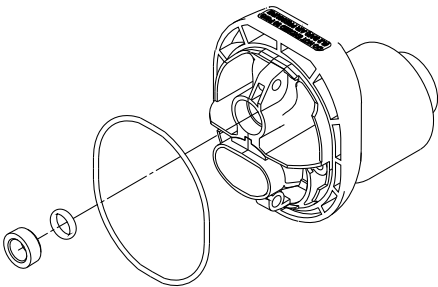

**G** MPA2222 Vacuum Endcap Kit  
Code: 8994026711

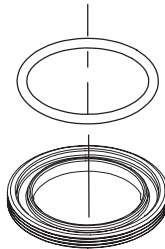

**H** MPA0993 Lock Ring and O-ring Kit  
Code: 8993007911

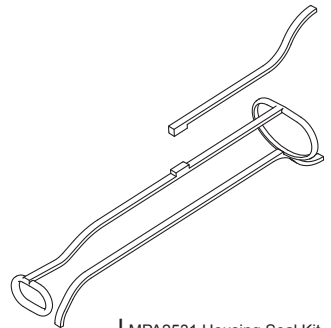

**I** MPA2531 Housing Seal Kit  
Code: 8994012911



**Mirka 10,000 rpm  
Two-handed 200 mm (8 in.)  
RANDOM ORBITAL SANDERS**

**Declaration of conformity**

KWH Mirka Ltd.  
66850 Jeppo, Finland

declare on our sole responsibility that the products 200 mm (8 in.) 10,000 rpm Two-handed Random Orbital Sanders (see "Product Configuration/Specifications" table for particular model) to which this declaration relates are in conformity with the following standard(s) or other normative document(s) EN ISO 15744:2008. Following the provisions of 89/392/EEC as amended by 91/368/EEC & 93/44/EEC 93/68/EEC Directives and consolidating Directive 2006/42/EC

Jeppo 13.06.2016



Stefan Sjöberg, CEO

Place and date of issue

Company

**Operator Instructions**

Includes – Parts Page, Parts List, Sander Spare Parts Kits, Please Read and Comply, Proper Use of Tool, Work Stations, Putting the Tool Into Service, Operating Instructions, Product Configuration/Specifications Tables, Trouble Shooting Guide

**Important**

Read these instructions carefully before installing, operating, servicing or repairing this tool. Keep these instructions in a safe accessible location.



**Manufacturer/Supplier**

KWH Mirka Ltd.  
66850 Jeppo, Finland  
Tel: + 358 20 760 2111  
Fax: +358 20 760 2290

**Required Personal Safety Equipment**

Safety Glasses      Breathing Masks  
Safety Gloves      Ear Protection

**Recommended Airline  
Size - Minimum**

10 mm      3/8 in

**Recommended Maximum  
Hose Length**

8 meters      25 feet

**Air Pressure**

Maximum Working Pressure    6.2 bar    90 psig  
Recommended Minimum      NA      NA

## Please Read and Comply with

- 1) General Industry Safety & Health Regulations, Part 1910, OSHA 2206, available from: Superintendent of Documents; Government Printing Office; Washington DC 20402.
- 2) Safety Code for Portable Air Tools, ANSI B186.1 available from: American National Standards Institute, Inc.; 1430 Broadway; New York, New York 10018.
- 3) State and Local Regulations.

## Proper Use of Tool

This sander is designed for sanding all types of materials i.e. metals, wood, stone, plastics, etc. using abrasive designed for this purpose. Do not use this sander for any other purpose than that specified without consulting the manufacturer or the manufacturer's authorized supplier. Do not use back-up pads that have a working speed less than 10,000 rpm free speed.

## Work Stations

The tool is intended to be operated as a hand-held tool. It is always recommended that the tool be used when standing on a solid floor. It can be used in any position but before any such use, the operator must be in a secure position and have a firm grip and footing, and be aware that the sander can develop a torque reaction. See the section "Operating Instructions".

## Operating Instructions

- 1) Read all instructions before using this tool. All operators must be fully trained in its use and aware of these safety rules. All servicing and repairs must be carried out by trained personnel.
- 2) Make sure the tool is disconnected from the air supply. Select a suitable abrasive and secure it to the back-up pad. Take care to center the abrasive on the back-up pad.
- 3) Always wear the required safety equipment when using this tool.
- 4) When sanding always place the tool on the work then start the tool. Always remove the tool from the work before stopping. This will prevent gouging of the work due to excess speed of the abrasive.
- 5) Always disconnect the air supply from the sander before fitting, adjusting or removing the abrasive or back-up pad.
- 6) Always adopt a firm footing and/or position and be aware of the torque reaction developed by the sander.
- 7) Use only correct spare parts.
- 8) Always ensure that the material to be sanded is firmly fixed to prevent its movement.
- 9) Check hose and fittings regularly for wear. Do not carry the tool by its hose; always take care to prevent the tool from being started when carrying the tool with the air supply connected.
- 10) Dust can be highly combustible. The vacuum dust collection bag should be cleaned or replaced daily or when bag reaches half full or 2.3 kg (5 lbs.). Cleaning or replacing of bag also assures optimum performance.
- 11) Do not exceed maximum recommended air pressure. Use safety equipment as recommended.
- 12) The tool is not electrically insulated. Do not use where there is a possibility of coming into contact with live electricity, gas pipes, water pipes, etc. Check the working area before operation.
- 13) Take care to avoid entanglement of the moving parts of the tool with clothing, ties, hair, cleaning rags, etc. If entangled, it will cause the body to be pulled towards the work and moving parts of the machine and can be very dangerous.
- 14) Keep hands clear of the spinning pad during use.
- 15) If the tool appears to malfunction, remove from use immediately and arrange for servicing and repair.
- 16) Do not allow the tool to free-speed without taking precautions to protect any persons or objects from the loss of the abrasive or pad.

## Putting the Tool into Service

Use a clean lubricated air supply that will give a measured air pressure at the tool of 6.2 bar (90 psig) bar when the tool is running with the lever fully depressed. It is recommended to use an approved 10 mm (3/8 in.) x 8 m (25 ft) maximum length airline. It is recommended that the tool be connected to the air supply as shown in Figure 1.

Do not connect the tool to the airline system without incorporating an easy to reach and operate air shut-off valve. The air supply should be lubricated. It is strongly recommended that an air filter, regulator and lubricator (FRL) be used as shown in Figure 1 as this will supply clean, lubricated air at the correct pressure to the tool. Details of such equipment can be obtained from your supplier. If such equipment is not used then the tool should be manually lubricated.

To manually lubricate the tool, disconnect the airline and put 2 to 3 drops of suitable pneumatic motor lubricating oil such as Fuji Kosan FK-20, Mobil ALMO 525 or Shell TORCULA® 32 into the hose end (inlet) of the machine. Reconnect tool to the air supply and run tool slowly for a few seconds to allow air to circulate the oil. If the tool is used frequently, lubricate it on a daily basis or lubricate it if the tool starts to slow or lose power.

It is recommended that the air pressure at the tool is 6.2 bar (90 psig) while the tool is running. The tool can run at lower pressures but never higher than 6.2 bar (90 psig).

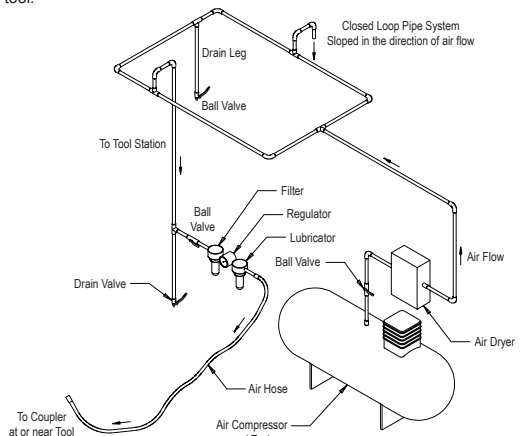



## Product Configuration/Specifications: 10,000 rpm Random Orbital Sander

Orbit	Vacuum Type	Pad Size mm (inch)	Model Number	Product Net Weight kg (pounds)	Height mm (inch)	Length mm (inch)	Power watts (HP)	Air Consumption LPM (scfm)	*Noise Level dBA	*Vibration Level m/s <sup>2</sup>	*Uncertainty K m/s <sup>2</sup>
5mm (3/16 in.)	Central Vacuum	200 (8)	Mirka® ROS2-850CV	1.56(3.42)	126.6 (4.98)	352.2 (13.87)	343 (0.46)	651 (23)	77	4.87	0.98
5mm (3/16 in.)	Self-Gen. Vacuum	200 (8)	Mirka® ROS2-850DB	1.55(3.41)	126.6 (4.98)	352.2 (13.87)	343 (0.46)	651 (23)	90	5.30	1.02

The noise test is carried out in accordance with EN ISO 15744:2008 - Hand-held non-electric power tools - Noise measurement code - Engineering method (grade 2) and EN ISO 11203:2009 Acoustics - Noise emitted by machinery and equipment - Determination of emission sound pressure levels at a work station and other specified positions from the sound power level.

The vibration test is carried out in accordance with EN ISO 28927-3, Hand-held portable power tools – Test method for evaluation of vibration emission – Part 3: Polishers and rotary, orbital and random orbital sanders.

Specifications subject to change without prior notice.

\*The values stated in the table are from laboratory testing in conformity with stated codes and standards, and are not sufficient for risk evaluation. Values measured in a particular work place may be different than the declared values. The actual exposure values and amount of risk or harm experienced to an individual are unique to each situation and depend upon the surrounding environment, the way in which the individual works, the particular material being worked, work station design as well as upon the exposure time and the physical condition of the user. KWH Mirka, Ltd. cannot be held responsible for the consequences of using declared values instead of actual exposure values for any individual risk assessment.

Further occupational health and safety information can be obtained from the following websites:

<https://osha.europa.eu/en> (Europe)

<http://www.osha.gov> (USA)

## Troubleshooting Guide

Symptom	Possible Cause	Solution
Low power and/or low free speed	Insufficient air pressure.	Check air line pressure at the Inlet of the Sander while the tool is running at free speed. It must be 6.2 Bar (90 psig/620 kPa).
	Clogged Muffler(s).	See the "Housing Disassembly" section for Muffler removal. The Item 58 Muffler can be back-flushed with a clean, suitable cleaning solution until all contaminants and obstructions have been removed. If the Muffler can not be properly cleaned then replace it. (See the "Housing Assembly" section).
	Plugged Inlet screen	Clean the Inlet Screen with a clean, suitable cleaning solution. If the Screen cannot be cleaned, replace it.
	One or more worn or broken vanes	Install a complete set of new Vanes (all vanes must be replaced for proper operation). Coat all vanes with quality pneumatic tool oil. See "Motor Disassembly" and "Motor Assembly".
	Internal air leakage in the Motor Housing indicated by higher than normal air consumption and lower than normal speed.	Check for proper Motor alignment and Lock Ring engagement. Check for damaged O-Ring in Lock Ring groove. Remove Motor Assembly and Reinstall the Motor Assembly. See "Motor Disassembly" and "Motor Assembly".
	Motor parts worn	Overhaul Motor. Contact authorized Mirka Service Center.
	Worn or broken Spindle Bearings.	Replace the worn or broken Bearings. See "Motor Disassembly" and "Motor Assembly".
Air leakage through the Speed Control and/or Valve Stem.	Dirty, broken or bent Valve Spring, Valve or Valve Seat.	Disassemble, inspect and replace worn or damaged parts. See "Housing Disassembly" and "Housing Assembly".
Vibration/rough operation.	Incorrect Pad.	Only use Pad sizes and weights designed for the machine.
	Addition of interface pad or other material.	Only use abrasive and/or interface designed for the machine. Do not attach anything to the Sander Pad face that was not specifically designed to be used with the Pad and Sander.
	Improper lubrication or buildup of foreign debris.	Disassemble the Sander and clean in a suitable cleaning solution. Assemble the Sander. (See "Service Manual".)
	Worn or broken Rear or Front Motor Bearing(s).	Replace the worn or broken Bearings. See "Motor Disassembly" and "Motor Assembly".
	For vacuum machines it is possible to have too much vacuum while sanding on a flat surface, causing the pad to stick to the sanding surface.	For DB machines add extra washer(s) to the pad spindle to increase the gap between the pad and shroud. For CV machines reduce vacuum through the vacuum system and/or add extra washer(s) to the pad.

# MIRKA



**KWH MIRKA LTD**

Finland

**Brazil** Mirka Brasil Ltda.

**Canada** Mirka Abrasives Canada Inc.

**China** Mirka Trading Shanghai Co., Ltd

**Finland & Baltics** KWH Mirka Ltd

**France** Mirka Abrasifs s.a.r.l.

**Germany** Mirka Schleifmittel GmbH

**India** Mirka India Pvt Ltd

**Italy** Mirka Italia s.r.l.

**Mexico** KWH Mirka Mexicana, S.A. de C.V.

**Russia** Mirka Rus LLC

**Singapore** Mirka Asia Pacific Pte Ltd

**Spain** KWH Mirka Ibérica S.A.U.

**Sweden** Mirka Scandinavia AB

**Turkey** Mirka Turkey Zımpara Ltd Şirketi

**United Kingdom** Mirka (UK) Ltd

**USA** Mirka Abrasives, Inc

For contact information,  
please visit [www.mirka.com](http://www.mirka.com)

Quality from start to finish

