



750 Series & 1500 Series
Solar Air Heater / Solar Furnace Owner's Manual



V7, Released 05.07.2024 to print

Questions? Issues?

Email: info@arcticasolar.com | Website: www.arcticasolar.com | Phone: (714)-698-9779

Thank you for purchasing the Arctica Solar 750 Series and / or 1500 Series Solar Air Heater / Solar Furnace. This manual will guide you through the set up and installation of your purchased heater.

This heater is a simple product, and with proper installation and maintenance should bring you years of free, renewable, supplemental heating to the adoptive space.

One 750 under full sunlight can generate close to 800 W / 2,500 BTUh of space heating.

One 1500 under full sunlight can generate close to 1,500 W / 5,000 BTUh of space heating.

This manual will guide you through the following Sections about your new solar air heater.

*We recommend you read the entire owner's manual and install guidance before attempting to install your new heater. **Careful installation** is the number one factor in ensuring a long, successful heater lifetime!*

Sections:

1. Items included and not included with the heater purchase – Pg 3
2. Tools required for heater prep and installation – Pg 8
3. Preparation of the heater for installation – Pg 8
4. South Facing Vertical Wall Installation (recommended) – Pg 16
5. Mounting and connection of the 10W Solar Panel – Pg 24
6. Interior vent covers and intake air filtration – Pg 27
7. Connection to the Heat-Only Thermostat – Pg 28
8. Linking 2x 750 Heaters on an Exterior Frame – Pg 29
9. Heater Lifetime Care Guide – Pg 29
 1. Washing intake filter
 2. Cleaning heater front glass
 3. Preparing for off season (summer)
 4. Cleaning the ducting
 5. Replacing the fan
10. Addendum and Additional Information – Pg 31

Section 1.0 - Items Included and *not* Included with the Heater

The following items are included with your heater shipment.

- 1x 1500 SERIES SOLAR AIR HEATER and / or 1x-2x 750 SERIES SOLAR AIR HEATERS



- 4X WALL MOUNTING BRACKETS, 4x 2.5" STAINLESS LAG BOLTS & WASHERS, 4x HEX, STAINLESS, #8 x 1/2" SELF DRILLING SCREWS – For wall attach of mounting brackets supporting the heater and securing mounting brackets to heater side wall.



- 1X HEAT ONLY THERMOSTAT – *(included in the PV Fan Kit)*



- 1X INTAKE COLLAR WITH FAN ASSEMBLY + THERMAL SWITCH + THERMOSTAT WIRE LEADS – draws **COOL** air in. *Once assembled the fan sticker points into the heater! (included in the PV Fan Kit)*



- 1X EXHAUST COLLAR WITH GRAVITY DAMPER – allows **HOT** air out *(included in the PV Fan Kit)*



- 8X SELF PIERCING LATH SCREWS, #8 x 3/4" – 4x per intake and 4x per exhaust collar attachment to the heater metal back sheet. *(included in the PV Fan Kit)*



- 1X 10W SOLAR PANEL WITH MALE DC OUT– for plugging into intake collar assembly power. The 750 comes with a 10W standard panel, the 1500 with a 10W skinny panel *(included in the PV Fan Kit)*



OR



- 1X SOLAR PANEL MOUNTING BRACKET & 4X PHILIPS, STAINLESS, #8 X 3/8" SCREWS AND WASHERS & 2X (standard PV panel) OR 3X (long form PV panel) HEX, STAINLESS, #8 X 3/8" SELF DRILLING SCREWS – to hold and secure solar panel to bottom or side of heater, attach solar panel to the solar panel mounting bracket and attach bracket to the heater side wall. *(included in the PV Fan Kit)*

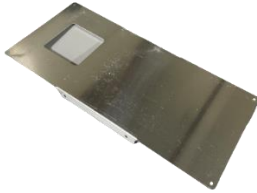

OR



AND

- 1X WASHABLE FOAM INTAKE COLLAR FILTER – to filter the intake air stream before it enters the heater.



- 1X 6' PCS OF METALIZED DUCT TAPE – for securing wiring harness to back of the heater prior to install and covering up unused intake and exhaust duct hole options on heater metal back sheet. *(included in the PV Fan Kit)*
- 1X TEMPLATE PATTERN ON BACK OF THE HEATER BOX– for installer to cut out and use as template for location of chosen intake and exhaust holes in your specific install.



- THIS OWNERS' MANUAL – also available digitally from our website www.arcticasolar.com on the product page

Items Not Included:

These items are likely needed to complete your installation but are NOT provided with the heater itself. They are typically in stock inventory at nearly all big box hardware stores (Lowe's, Home Depot, ect)

- 4" ducting / flexible insulated ducting



- 2x (one for intake, one for exhaust) indoor duct cover / air diffusers, more styles available online. 4" bath drain covers can also make for stylish intake and exhaust duct covers (right most picture).

Section 2.0 – Tools required for heater preparation and installation

These are the tools likely required for preparation and installation of your heater in your application.

Tools:

- For clothes dryer style non-insulated duct routing – Cordless drill, a 4" hole drill bit – available at most hardware stores.
- For insulated / insulated flexible ducting – Cordless drill, a 6^{3/8}" hole drill bit – available at most hardware stores in electrical section, common tool for recessed lighting installation.
- For prepping the heater – Snip pliers, box knife with 1.5" blade, impact driver with Philips bit OR Philips head screwdriver.
- For mounting – Cordless drill, common drill bits (including 5/32" pilot bit), caulking gun, impact driver with hex (including long ¼" hex socket and a 7/16" hex socket) & Philips bits OR Philips head screwdriver.

Section 3.0 – Preparation of the heater for installation

Let us review some overall details and physical dimensions of the heater for the 1500. All steps are similar for the 750 heaters. Guidance for linking multiple 750 heaters is provided in Section 8.0. Figure 1 shows the heater physical size dimensions which may be useful in sizing its permanent location or deciding how many heaters are needed in your application. Figure 2 shows the intake and exhaust punch locations and details (Figure 2a). Figure 3 shows how the 4x mounting brackets interface with the heater to provide mounting support. Figure 3 shows detailed views of the mount bracket and solar panel bracket installation.

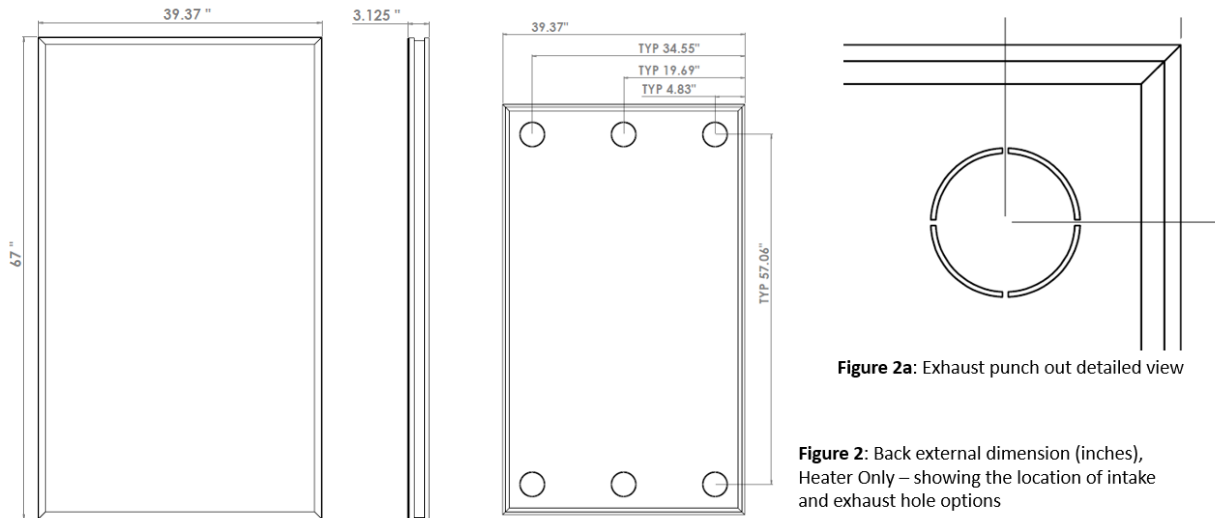

Figure 1: 1500, Gen 3 Heater Physical Dimensions

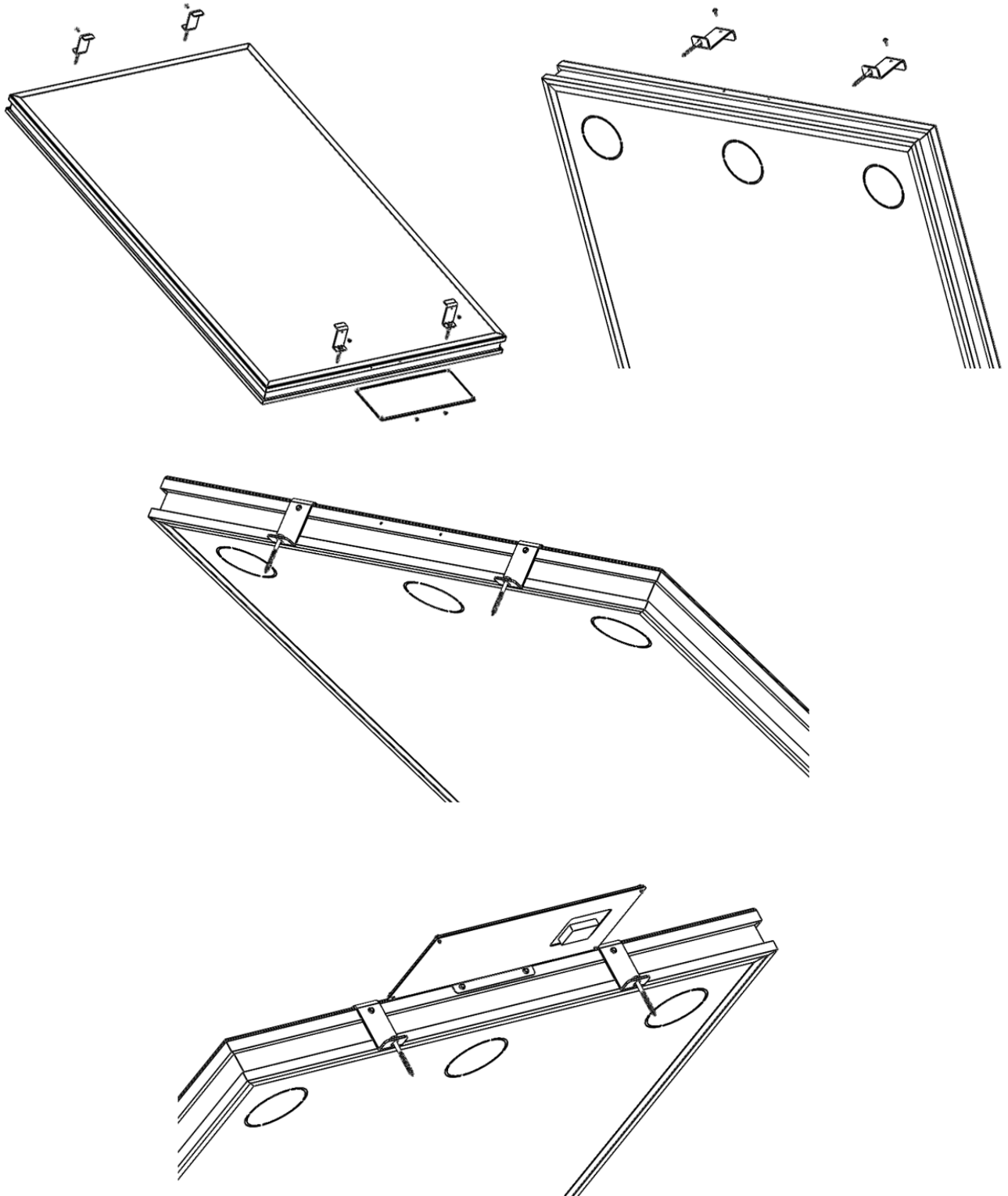

Figure 3: Exploded and collapsed views of the heater mounting brackets and standard solar panel bracket attached to the heater walls.

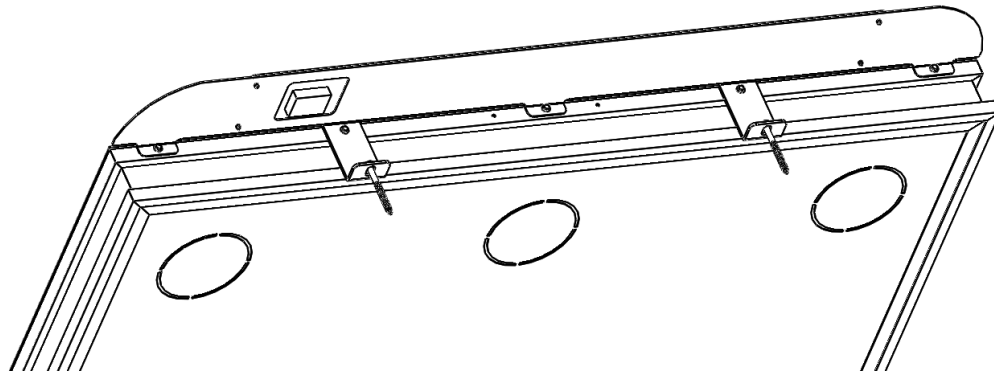

Figure 4: Long form solar panel bracket attached to the 1500 series heater walls.

3.1. Determine where to mount your heater

3.1.1. Using the provided mounting template as a guide, find the location of the wall studs in the area you want to mount the heater. The template is printed onto the back side of the heater cardboard box. Cut out the desired exhaust and intake holes **OUTSIDE** the dashed lines of the template. **BE SURE TO CHECK YOUR TEMPLATE ALIGNMENT TO YOUR SPECIFIC HEATER** by overlaying the template with holes cut onto the back of the heater to make sure the TEMPLATE holes properly align with the desired INTAKE and EXHAUST holes on the heater.

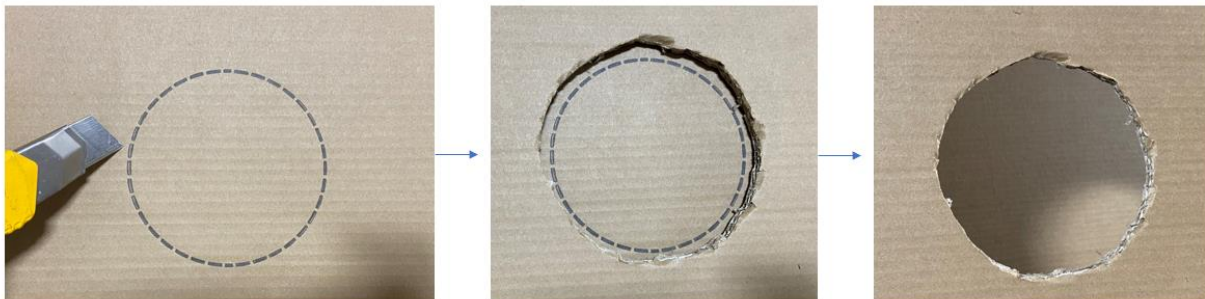
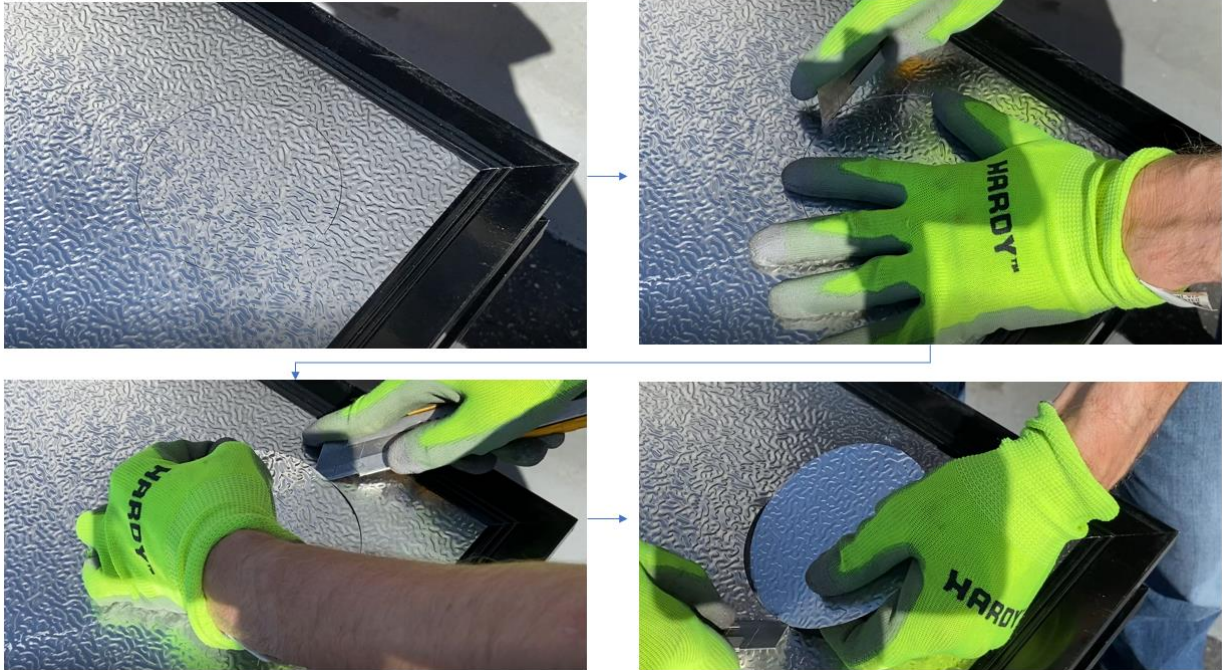

Figure 3.1.1 – Cut the desired intake and exhaust locations from the template outside of the template dotted line. Verify your template aligns well with your heater by placing it over the back of the heater before you use the template to make you wall duct penetrations.

3.1.2. With mounting area and location of the wall studs identified, determine which 1x of the 3x exhaust punchout options you will use, and which 1x of the 3x intake punchout options you will use in your installation. The heater needs to undergo preparation before being ready for permanent installation, namely install of the exhaust collar and intake collar + fan assembly.

3.1.3. We are now going to install the intake and exhaust collars onto the rear of the heater. *We recommend placing the heater glass face down on a table with a soft surface to not damage or scratch the glass.* You can use the heater cardboard box as such a surface. Using hand snips OR a box knife, remove the aluminum punchouts for the exhaust and intake locations you wish to use. Exhaust and intake need to be located on opposing ends of the heater. Heater can be mounted portrait or landscape, as guided in Section 4.0.



3.2. Install heater exhaust and intake collars, thermal switch and wire harness

Watch these steps on our Instruction Video at: <https://www.youtube.com/watch?v=og59R0mGHt0>

3.2.1. Using a box knife or razor with a 1.0-1.5” blade, remove the insulation from behind the selected exhaust and intake punchouts. With a shop vac, vacuum out any loose insulation from the hole and interior of the heater in both locations. Do this step for both the intake and exhaust collar holes.



3.2.2. Remove the intake fan assembly from its bag and untwist the wires. Insert into the thermal switch into the exhaust hole 2-3". Use duct tape to secure switch wiring to the heater wall and backing as shown. The thermal switch is OPEN when the heater is below 30 C and CLOSED when the interior of the heater is above 30 C and ready to deliver useful heating.

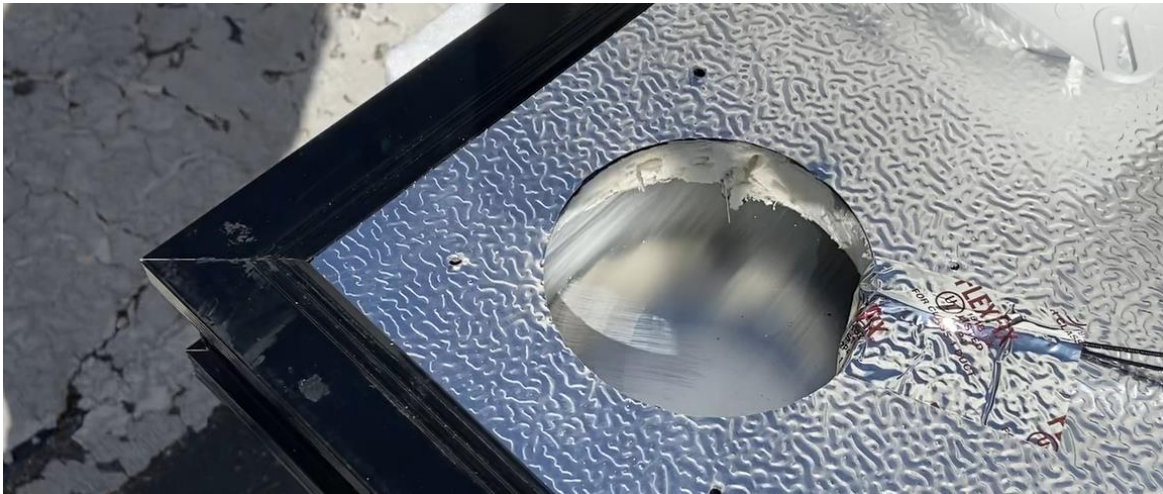

3.2.3. For installing the exhaust collar, place a bead of GE1 silicone sealant (or equivalent) on the back of the heater around the perimeter of the exhaust hole OR on the heater flange of the exhaust collar. Then **with the gravity damper in the proper orientation for your installation**, insert the exhaust collar and secure in place with the 4x provided self-tapping lath screws to the back plane of the heater. Do not over torque the screw as it will strip the heater back material!

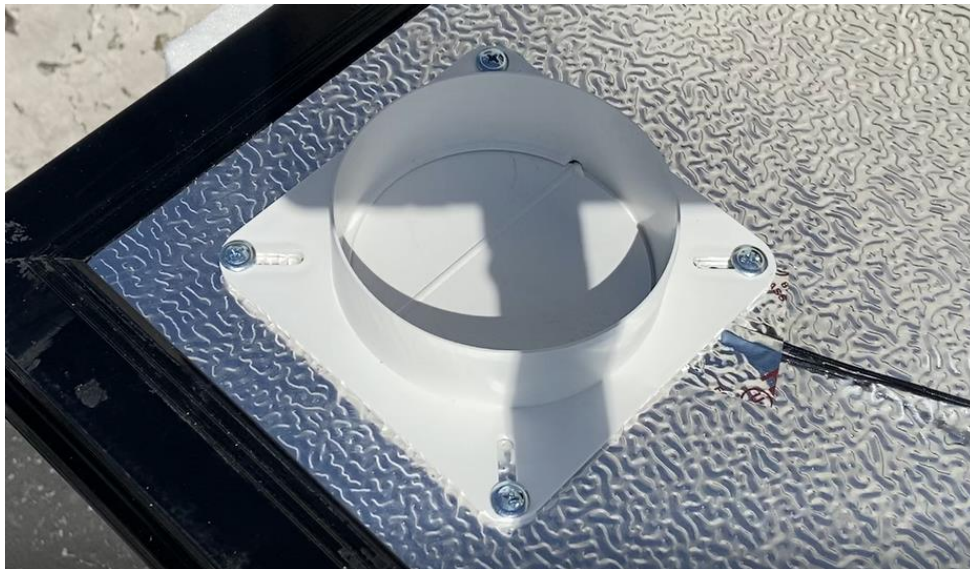
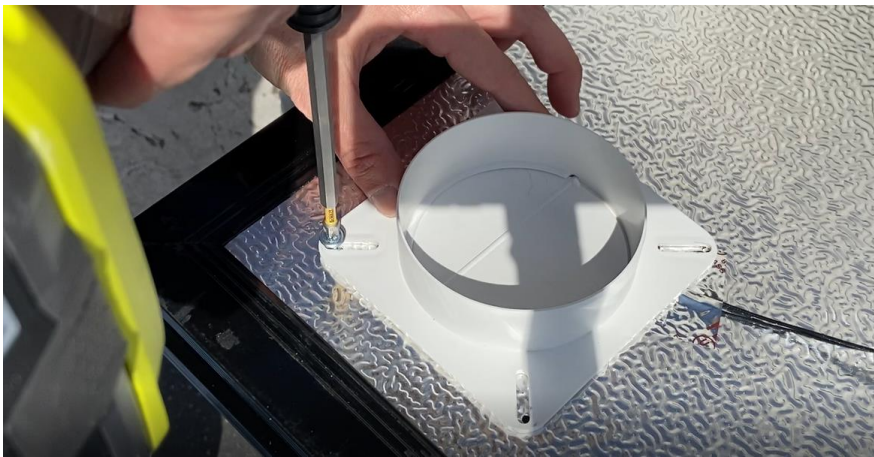

3.2.4. Using the provided duct tape, tape into place the thermal switch wires to the back of the heater and route the wires down to the determined intake collar location. Repeat Step 3.2.3 with the intake collar assembly (**BE SURE** to orient the collar such **THAT THE STICKER ON THE FAN POINTS INTO THE**

INTERIOR OF THE HEATER!). Be sure to route FAN power wires back out of the underside of the collar for connection to the 10W SOLAR PANEL. Use duct tape to guard wires from fraying against the sharp edge of the heater box intake collar hole, as we did with the thermal switch wires in the exhaust hole – bottom right picture of Step 3.2.2.

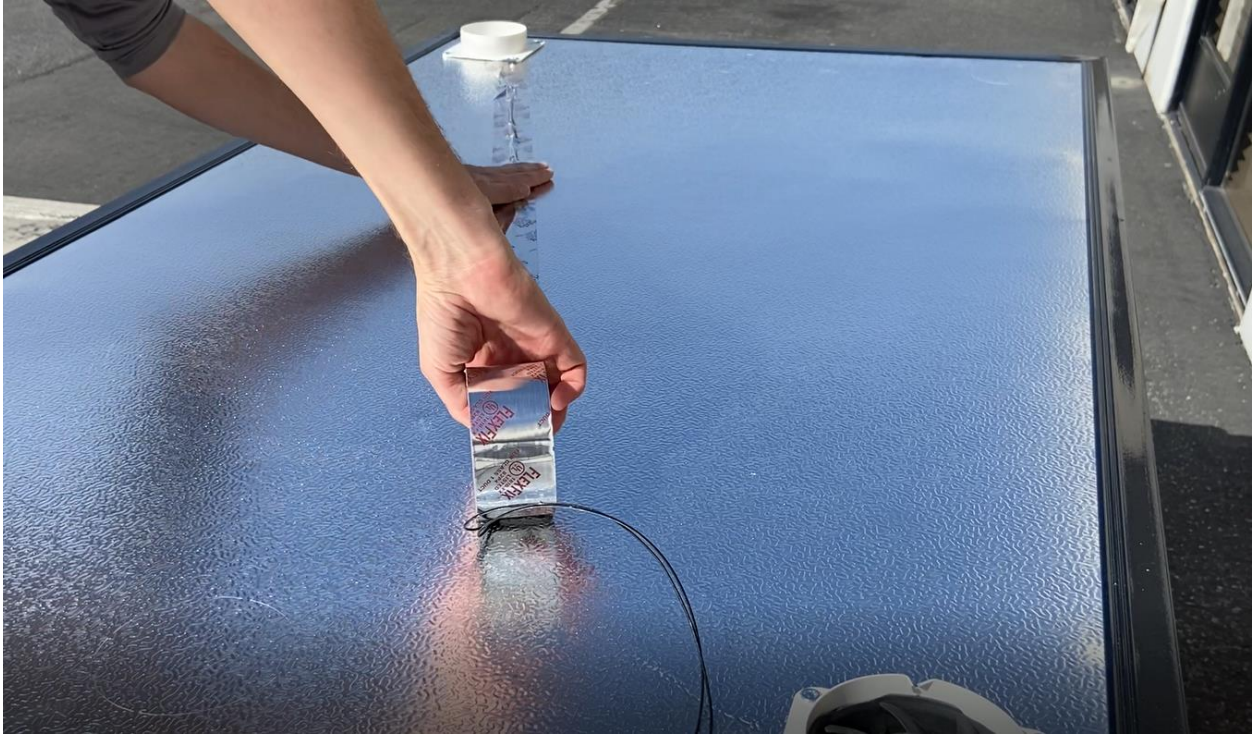

Tape thermal switch wires to the back of the heater using provided 6' of metalized all weather duct tape



Apply silicone to intake collar or the outer diameter of the intake hole on the heater back sheet.



Intake collar after installation with its proper orientation and with proper routing of the fan power lead and thermostat leads to the exterior of the heater. Let the fan power lead dangle near the bottom OR side of the heater, depending on your install orientation. Secure the intake collar with a silicone bead and 4x self-tapping lath sheet metal screws, same process as with the exhaust collar, Step 3.2.3.

3.2.5. Use remaining duct tape to cover the un-used intake and exhaust cut out locations as to prevent unwanted air flow loss (see picture below). The heater is now ready for installation. We recommend installing on a south or southwest facing vertical wall that receives plenty of winter season sunlight, as seen in Section 4.0.

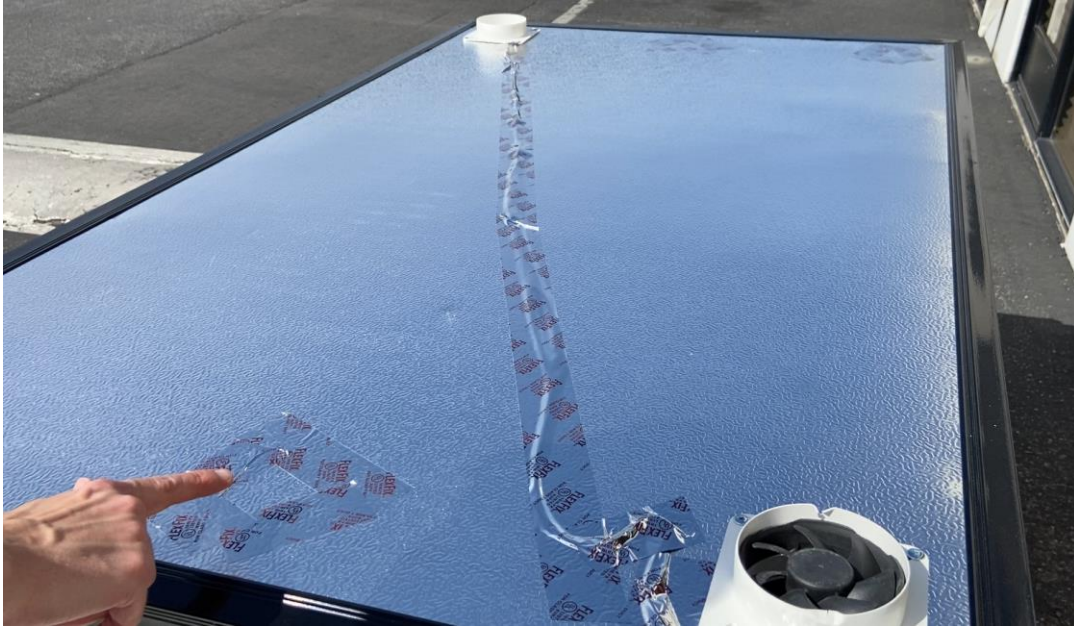

Section 4.0 – South facing vertical wall installation (recommended)

4.1. Making intake and exhaust holes and routing of ducting into the space

An exhaust (**hot air**) hole and intake (**cool air**) hole must be added to the adoptive structure. The cardboard template included with your heater and can be used to locate the selected intake and exhaust ducting holes per Section 3.1.1. Be sure to avoid placing planned intake and exhaust locations over top wall studs.

If routing through a wall with no vapor barrier and no need for insulation of ducting:

The process can be done in two ways. First is like the installation of a 4" dryer duct, as seen in videos referenced below. Locate wall studs prior to drilling to ensure that they will not interfere with the path of the heater ducting. **It is best to mount the heater closest to the point of use as possible** to cut down on heat loss through the transport of air to the use space, and fan pressure head loss due to long duct runs.

These videos can serve as reference to this part of the installation process:



YouTube: [How to install fume hood – link: https://youtu.be/9egwOazPJis](https://youtu.be/9egwOazPJis)



YouTube: [How to install dryer duct – link: https://youtu.be/HjK2ybx8-14](https://youtu.be/HjK2ybx8-14)

If routing through a wall where sealing the vapor barrier is required:

The use of insulated ducting is recommended. We recommend using a 6" ABS riser pipe / tube installed as a conduit for the flexible insulated ducting as seen in the process below.





Use a 6 3/8" hole bit to place a through hole on the exterior wall and opposite interior wall. Create holes such that there is a slight downward angle from interior to exterior to discourage moisture from entering the exterior hole and flowing inwards. Feed a 6" ABS tube and cut leaving 1/4" proud of the interior wall and exterior wall. Seal to interior wall and exterior wall (or vapor barrier) with a vapor barrier membrane or silicone sealant. Secure the conduit physically to the wall as needed. This tube will act as the conduit for the flexible ducting.

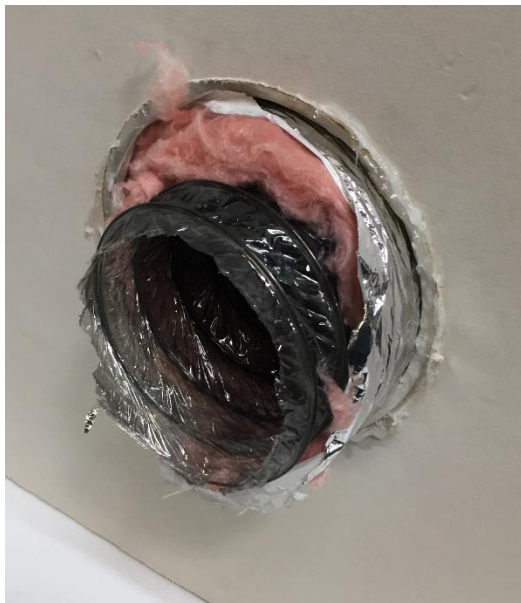

Route 4" insulated ducting into the conduit. Secure the inner membrane of the interior side ducting to the end of a 6" air diffuser with duct tape as shown.



A 6" interior air diffuser can now fit snugly into the 6" PVC conduit. Cut the exterior insulated ducting to the wall thickness (red arrow) but allow for extra interior ducting (which will compress back into the wall) to make connecting to the heater intake and exhaust collars easier.

4.2. Connecting the ducting to the heater exhaust and intake collars

Heater exhaust and intake collars interface with 4" ducting. Secure the duct to the collar using a screw clamp or duct tape. Once connected slide insulation and vapor barrier back over the clamp and wrap with duct tape or an additional screw clamp to secure in place.



Connect the 4" insulated ducting inside liner to the heater intake and exhaust using screw clamps as shown above



Slide duct insulation and foil external cover over the intake and exhaust collars and secure with duct tape or additional screw clamps

4.3. *Mounting the heater to the wall*

Before securing the wall, we recommend placing a strip of appropriately thick weather stripping along the perimeter of the back surface of the heater. This will discourage dust, debris, moisture, ect from accumulating between the heater and the install wall during its lifetime. Select the thickness of weather stripping appropriate for your mounting wall texture or type. Not required but recommended.

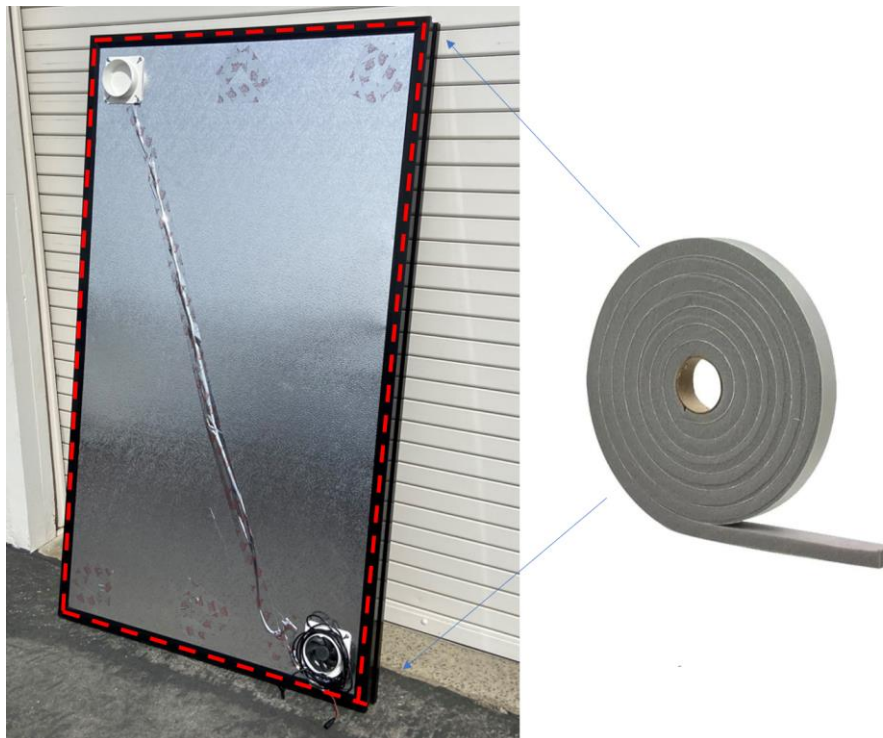

When deciding where to place the heater on the install wall, the selected heater intake and exhaust locations should fit between the structure exterior wall studs, as seen below in a caddy-corner exhaust and intake selection design.

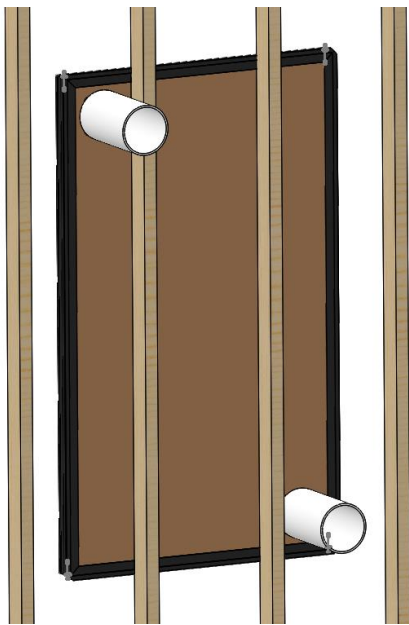

With the heater install location determined, heater prepared for installation, the exhaust and intake holes prepared, and duct routed and connected, we are ready to mount the heater. We recommend using a minimum of 2x people to HOLD IN PLACE the heater level against the installation wall with intake and exhaust collars properly connected to ducting and routed into the use space.

Then using a 3rd person, install one at a time the bottom mounting brackets into the appropriate wall stud. Use a 5/32" bit to the proper depth to establish a pilot hole into the stud for the 1/4" stainless lag bolt with 1/4" washer with a 7/16" hex bit impact driver.

Alternatively, the bottom mounting brackets can be installed prior to heater placement provided the intake duct hole is large enough to accept the intake collar as it is tilted into place against the wall. The heater can then be inserted into the bottom bracket and tilted back vertical against the wall and held in place by the installer until the top brackets are also installed.

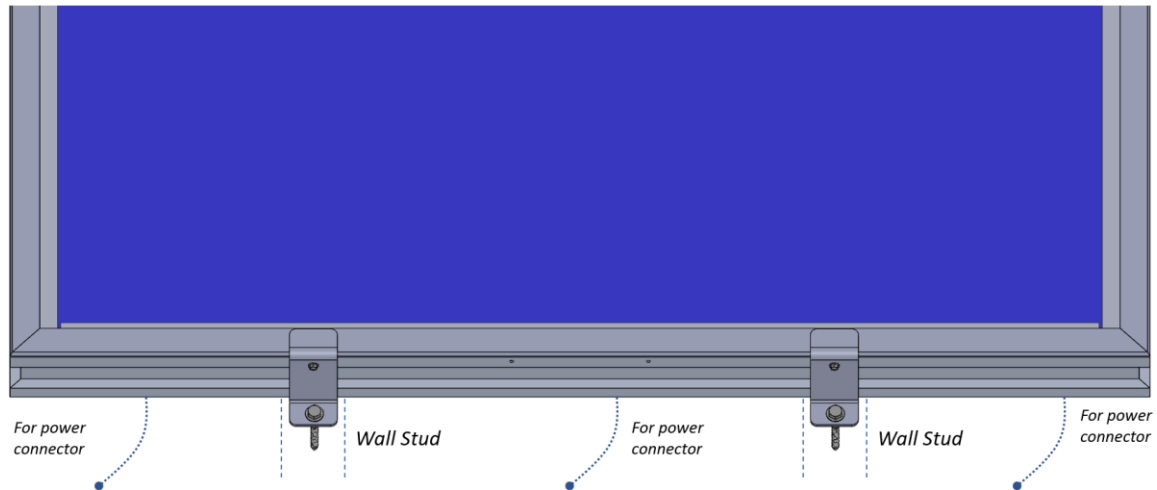

Take care to properly route fan power female lead out the side or bottom of the heater and away from being crimped by the bottom mounting brackets. Secure each bracket to the bottom side wall of the heater using the provided self-drilling #8 stainless, 1/2" length hex head screws as shown in the picture below with a 1/4" socket on an impact driver. This screw will penetrate the heater but will not pass through to the internal area or damage the heater performance. *These side screws are essential to prevent the heater from sliding out of its mounting brackets after installation!*

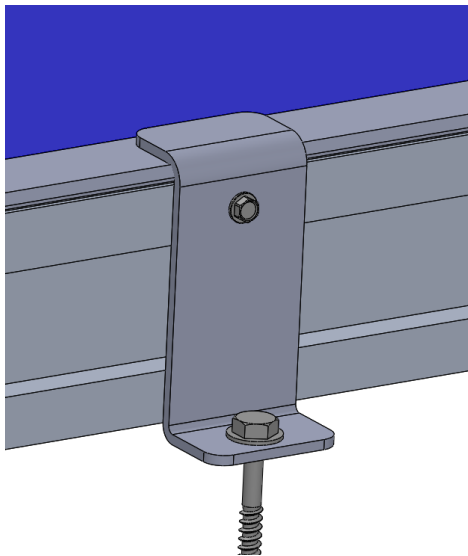

With bottom brackets secured, install the top mounting brackets by repeating the pilot and attachment steps used for the Bottom Mounting Brackets, including the securing of each top bracket to the heater top side wall using the stainless, #8 self-drilling hex head screws. The heater should be snug in its mounting brackets, but do not over torque which may impart too much stress into the heater or its glass.

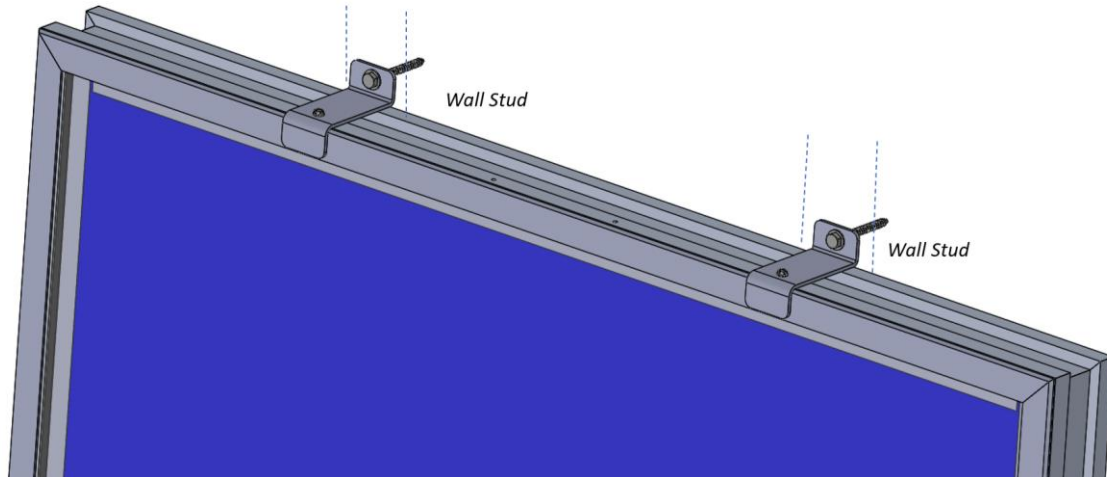

The heater is now properly captured between the 2x top and 2x bottom mounting brackets and should be secured for its operational lifetime. If the heater needs to be removed during its operating lifetime, these steps should be followed in reverse by first removing all 4x of the #8 stainless self-drilling screws before removing the top and then bottom mounting bracket with the heater properly supported.

Other mounting options

The heater can be mounted in a host of configurations, including but not limited to the following. The installation principles are the same as discussed for the portrait vertical wall mount.

1. Landscape wall mounting

When mounting landscape on a vertical wall, *you do not get the benefit of natural convection* helping with air circulation, but since the heater uses a powered fan, this is not required.



2. Roof mounting

Roof mounting is uncommon and comes with concerns of the heater glass being frequently soiled due to its mounting angle and difficulty in reaching it for regular cleaning, and concerns with water leakage through the ducting roof penetrations. We recommend roof mounts be completed by a licensed HVAC or roofing contractor to ensure best practice during the mounting and routing of ducting. Roof

mounting can also use commercially available PV (photovoltaic) solar mounting rails and hardware if desired.

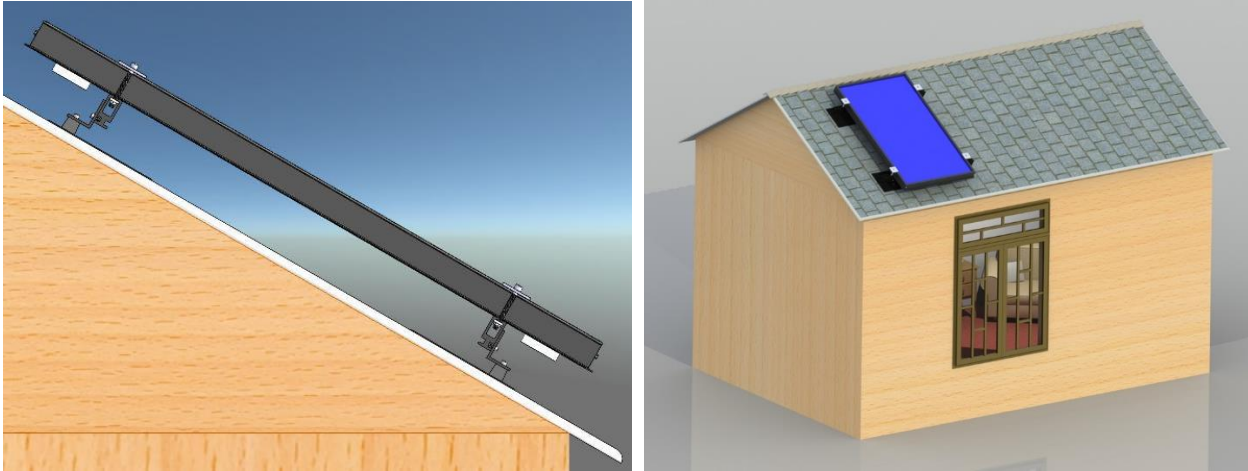

3. *Mounting on an exterior plenum / frame construction*

Some users of the product elect to mount the heaters to a custom exterior plenum or framing commonly made from wood or other construction materials. These plenums are not mounted to the adoptive structure, instead sitting adjacent the structure on the south or southwest side of the heated space. We recommend mounting the panels at a tilt angle ideal for your latitude solar in the winter, which can be determined from a calculator such as this one:

<http://www.solarelectricityhandbook.com/solar-angle-calculator.html>



Section 5.0 – Mounting and connection of the 10W solar panel

The heater is provided with a lightweight 10W PV panel with a DC MALE power out, a solar panel mounting bracket and associated mounting hardware. If you purchased the 750 series heater, the heater comes with a standard PV panel. If you purchased then 1500 series heater, the heater comes with a long form PV solar panel. The standard solar panel is provided with 4x stainless #8 x 3/8" length

Philips sheet metal screws and 4x #8 stainless washers for securing the solar panel to the solar panel mounting bracket. Also included are 2x #8 stainless, 3/8" length hex head self-drilling screws (3x for the long form PV panel) for attaching the solar panel bracket to the heater bottom side wall. Attach the solar panel to the mounting bracket using a hand Philips screwdriver for each screw and washer. Attach the solar panel mounting bracket to the heater bottom side rail as shown with a long 1/4" hex bit on an impact driver, as shown in the images below.

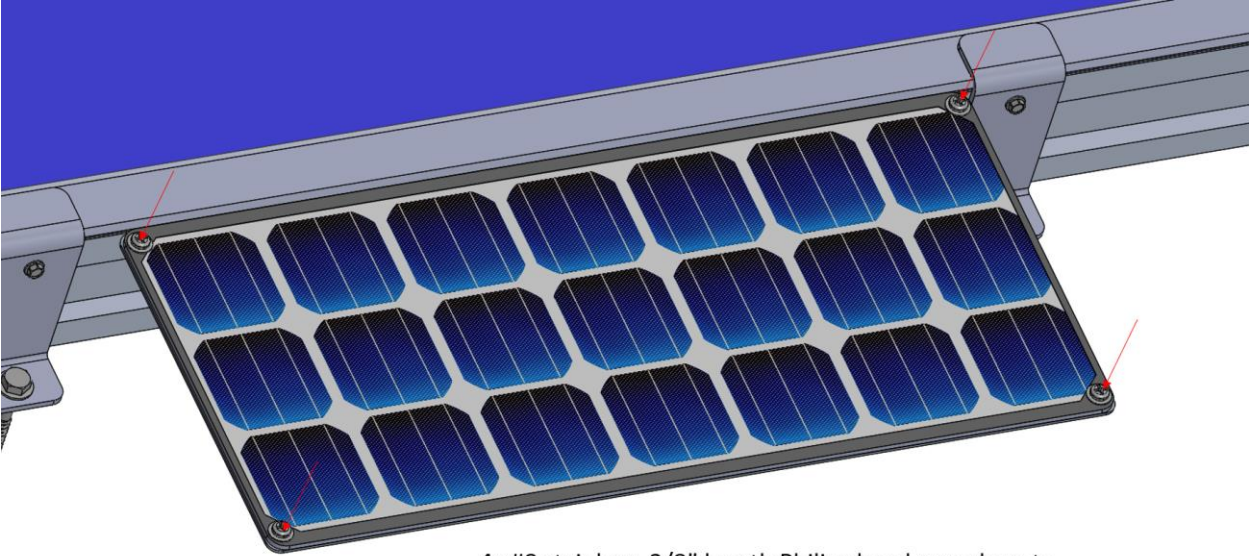

4x #8 stainless, 3/8" length Philips head + washers to connect solar panel to solar panel mounting bracket

2x #8 stainless, 3/8" length hex head bolts to connect solar panel mounting bracket to top of heater bottom side rail

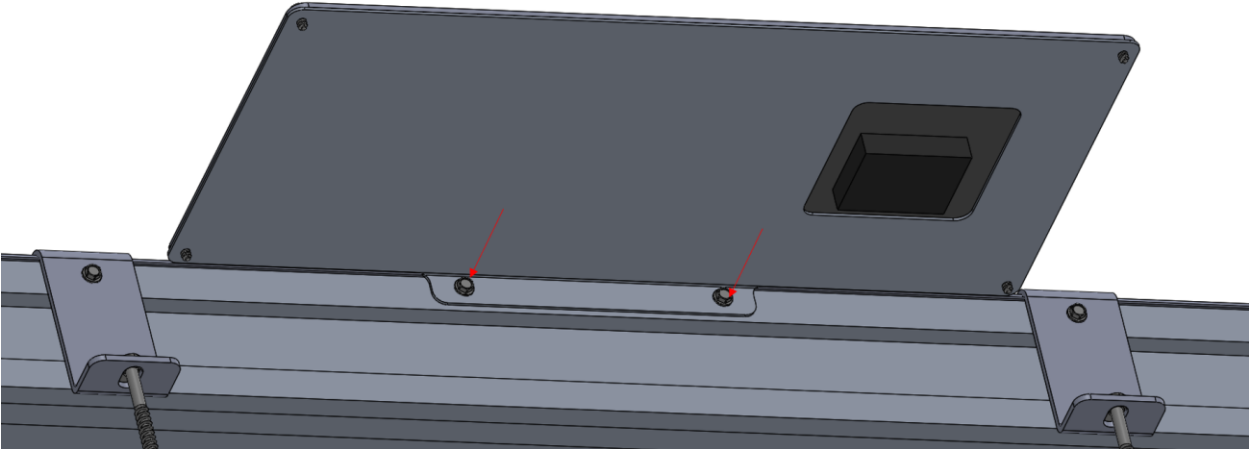

1500 Series long form PV panel:

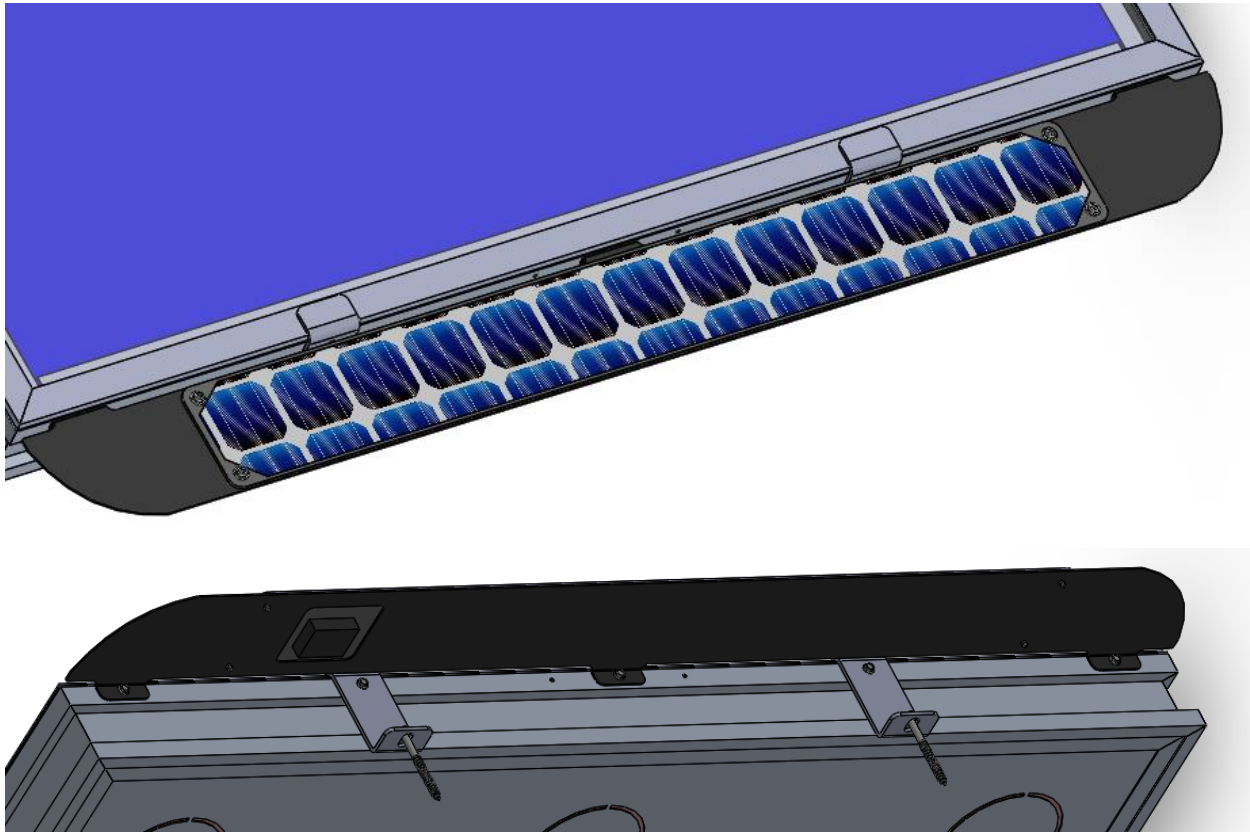

When placing the solar panel on the mounting bracket take care to route the panel wiring and electrical box through and into the hole in the mounting bracket as shown above. When mounting the solar panel to the heater, take care to connect the self-drilling screws into the top of the heater bottom side rail, in the same area as the mounting bracket side screws. This will prevent damage to the heater walls and allow the front surface of the solar panel to be flush with the top of the heater and prevent shading by the heater bottom lip of the solar panel during operation. An installed solar panel + solar panel mounting bracket is shown in the image below (standard on left, long form on right).



The solar panel is provided with a length of wire harness for mounting off the heater if it is necessary to do so. When mounting the solar panel off the heater, **be careful not to place the solar panel in an area where it will be shaded** by the heater panel or other features of the install location, such as a roof overhang, nearby vegetation, ect. Any shading of the solar panel during the day will cause the heater fan to lose power and stop circulating air and heat. Feel free to bend the tab on the solar panel mounting bracket to accommodate other mounting locations if needed for the application.

Be sure to remove the protective plastic cover from the solar panel prior to operation. Connect the MALE power plug from the solar panel to the FEMALE fan power lead at the base of the heater. We recommend securing this electrical interface with electrical tape or duct tape. Secure and route the PV panel wire against the installation wall as needed. Loop and store excess solar panel wire harness length with a zip tie or electrical tape.

Power to the heater can also be provided with a 12V AC to DC wall plug, which has a similar 5.5mm x 2.5 mm MALE power out as the provided solar panel, or another means of 12V DC power such as a battery.

Section 6.0 – Interior vent covers and intake air filtration

The heater is provided with a small, washable intake air filter which we recommend placing downflow of the intake collar, as seen below. This filter can be placed behind the interior intake vent collar for ease of access during the heater’s lifetime. We recommend washing the filter every 3 months to ensure a flow of clean air into the heater. Not filtering the air prior to intake into the heater may lead to excessive fouling of the interior of the heater.

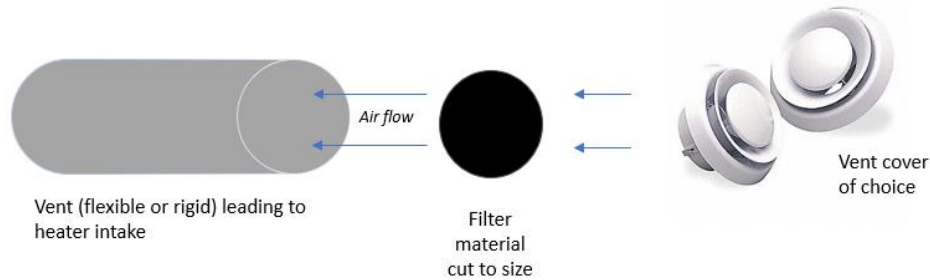

Different indoor intake and exhaust grill options exist at local big box hardware stores and online retailers. New filter material such as is shown below can also be purchased at local and online retailers as well as directly from Arctica Solar’s website.



Section 7.0 – Connection to the Heat-Only Thermostat

The 750 / 1500 heater has the option to be controlled by a heat-only thermostat provided with the heater. The intake collar wire harness includes a 12' wire pair which connects to the heat-only thermostat. Unravel the thermostat wire and route it through the wall(s) as necessary into the living / wheated space. Cut to length and re-strip the wire ends if needed.

Route the wire through the back of the thermostat backplate. Connect one wire to terminal **RH**. Connect the other to terminal **W**. The color of the wire to each terminal does not matter. Mount the thermostat backplate to the wall and reattach the front plate with the provided batteries installed.

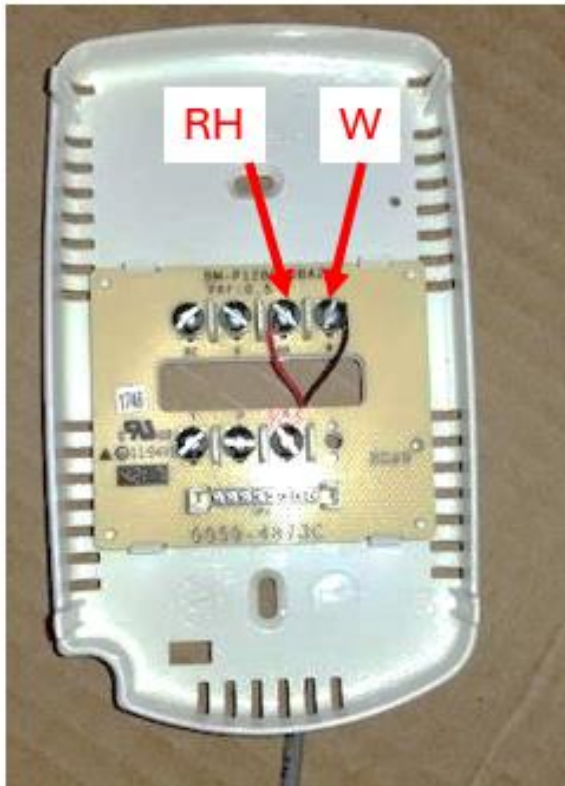

Set the thermostat to the desired room temp. The heater is activated by the thermal switch now internal to the exhaust collar of the heater – Step 3.2.2. When the inside of the heater reaches above 30 C / 86 F the heater will activate and start delivering warm air into the living space if the desired temperature is greater than the thermostat room temperature. Be careful to mount the thermostat a suitable distance from the exhaust of the heater.

If you want the heater to run continuously whenever it is above 30 C / 86 F AND there is enough sunlight on the 10W solar panel to activate the fan, or do not want to use the thermostat, twist the red and black leads from the thermostat wire together to short the circuit.

Section 8.0 – Linking multiple 750 Series Heaters on an exterior framing

This guidance is also provided on the 750 Series product page of our website. This can also be used for multiple 1500 series solar air heaters. The 750 series panels are designed to use ground shipping, and therefore can be linked using an external framing to provide similar heat output to a single 1500 series heater, which must be shipped freight. Using a 2-5" wood framing off the adoptive structure, the heaters can connect using ducting between the structure wall and the rear of the heaters as seen below. The exhaust from the first heater is linked using a 4" flexible duct or box duct connection to the intake of the second heater. The heaters are held in place with the 6x mounting brackets provided.

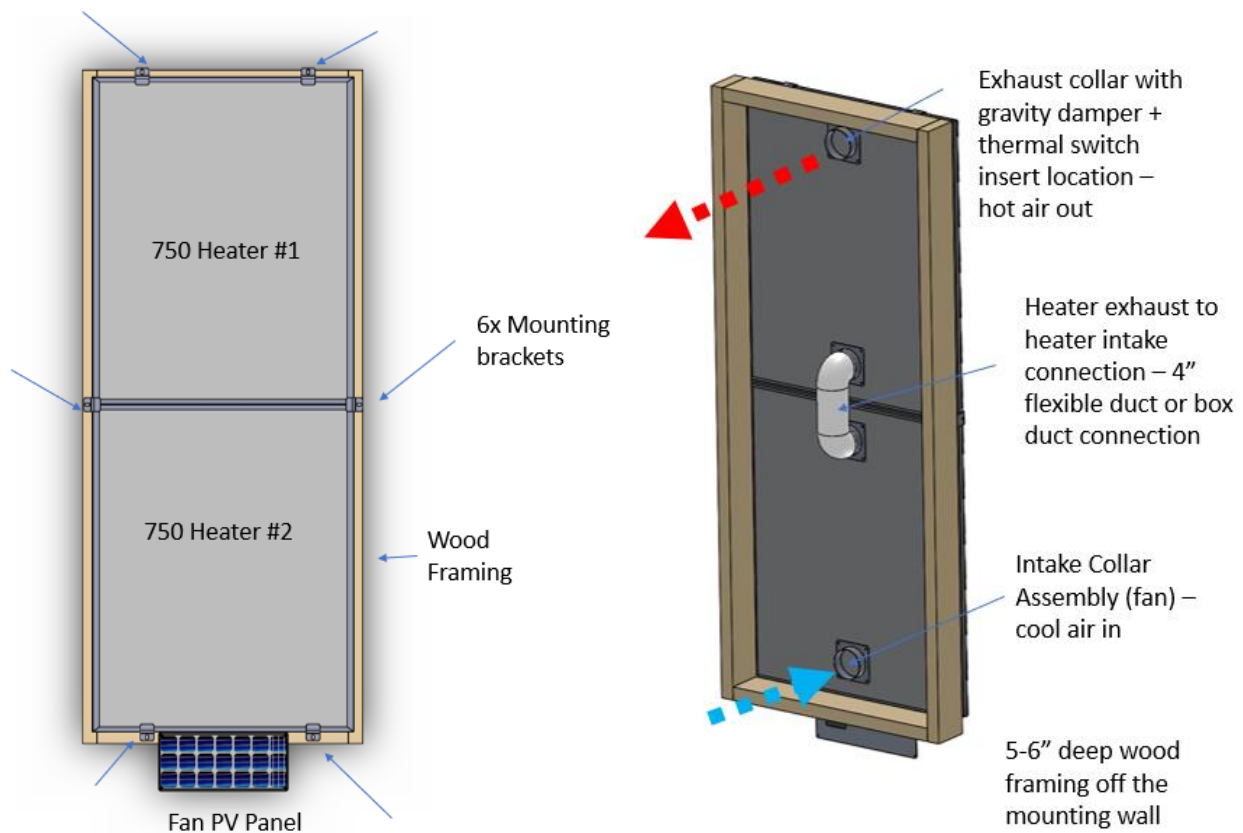

Section 9.0 – Heater lifetime care guide and suggestions

With proper maintenance, your Arctica Solar Air Heater should bring you years of free and renewable supplemental space heating. Here are suggestions for caring for the heater over its lifetime.

8.1. Washing intake air filter – every 3-6 months

With the heater installed, intake air should be filtered through the provided washable filter material. This prevents buildup of dust and debris inside the heater which can reduce performance over time. We

recommend positioning the filter material between the intake grill and the ducting leading to the intake / fan collar and hand washing this material every 3-6 months.

8.2. *Cleaning of heater front glass – every 3-6 months or as needed*

If the heater is mounted in the vertical wall position, it should not need frequent cleaning of the front glass. But cleaning of the glass at regular intervals, like that of home windows, will increase lifetime performance.

We recommend cleaning the front heater glass every 3 – 6 months while the heater is NOT in full sunlight. Clean it during cloudy days, or at dawn or dusk to reduce stress on the glass and potentially cause damage from rapid cooling.

Glass can be cleaned with Windex (or equivalent) and a lint-free rag or wipe, or with soapy water and then wiped clean and dry. Or use a soft sponge to scrub the glass, clean water to rinse and a squeegee and lint free towel to wipe dry.

8.3. *Preparing your heater for the Summer (off) Season – every 12 months*

Care must be taken to set up your heater during the off season as to not cause unwanted heating even with the thermostat off. Summer exposure will not damage the heater. We recommend the following steps:

8.3.1. Tape into place and seal off the gravity damper on the exhaust collar, or the exhaust ducting routed into the living space (see below). If left unsealed, naturally convective heat will bleed into the living space during the off season. We recommend taping the damper shut with duct tape or placing into the exhaust ducting a cut-to-size polyisocyanurate insulation “plug” which will choke any unwanted heat generation.

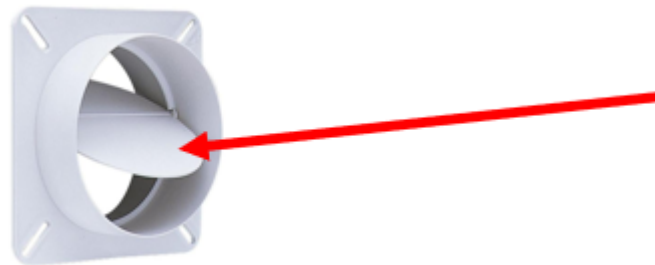

8.3.2. If possible, cover the glass of the heater with an off-season cover such as a piece of cardboard / plywood / ect to prevent collection of sunlight onto the panel.

8.4. *Cleaning of heater ducting – every 12 months or as needed*

Periodically the indoor intake and exhaust grills should be removed from the ducting and a shop vacuum used to vacuum out any collected dust in the ducting. Clean ducting will ensure clean air circulation inside of the heater and reduce dust fowling of the absorber rear surface.

In extreme soiling cases, the heater may need to be removed from the wall, intake and exhaust collars removed and vacuuming out of the interior of the heater itself with proper shop vacuum attachments or vacuum snake.

The front of the absorber is sealed off from airflow, so it should not require removal and cleaning. If, however, the absorber becomes heavily soiled, the glass can be removed (See 8.6) and the absorber serviced or replaced (not recommended).

8.5. *Replacement of the air circulation fan – as needed*

If the air circulation fan dies during service, Arctica keeps in stock a supply of replacement fans for purchase. The user will have to access the intake fan collar and BEND UP the 2x plastic tabs to release the fan (red arrows below). The fan uses a 2-pin electronic clip to connect to the heater wire harness (right picture). Remove the defective fan by squeezing this clip. The new fan can be installed by following this instruction in reverse. Make sure to place the fan in such that the *sticker on the fan is pointing INTO the heater*, so that air will be drawn into the intake.

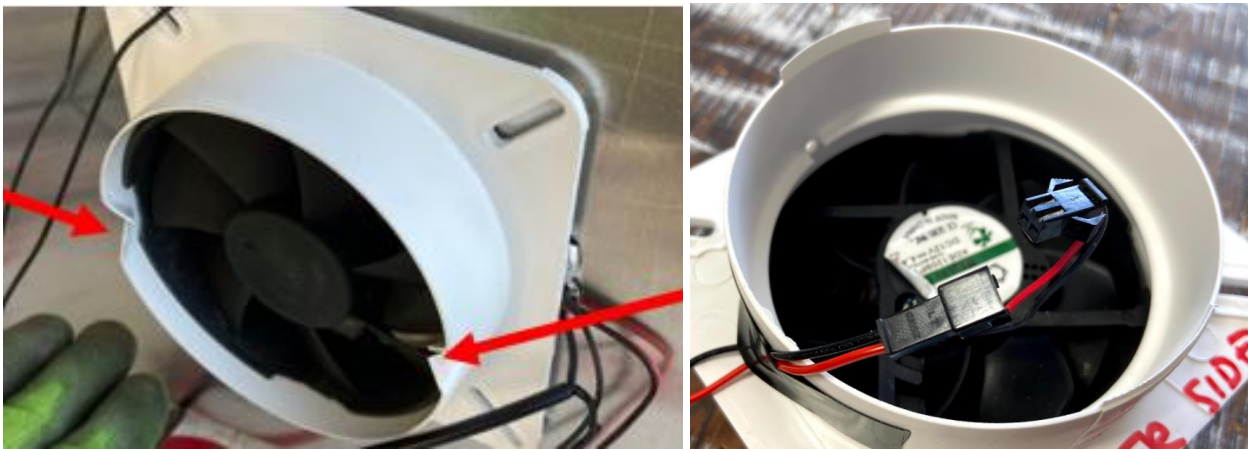

Section 10.0 – Addendum and Additional Information

This manual, all our instructional videos and all relevant product information can be seen at our website

www.arcticasolar.com

V7, Released 05.08.2024 to print

Questions? Issues?

Email: info@arcticasolar.com | Phone: (714)-698-9779