

1. Install Lock Body

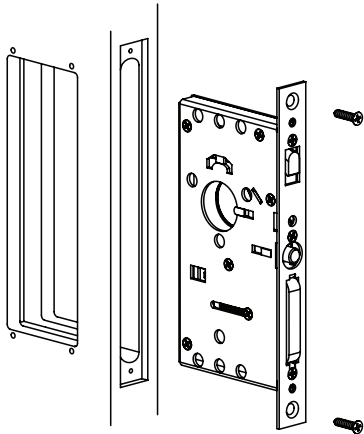

See template for door prep specifications

2. Install Drive Bar Cylinder

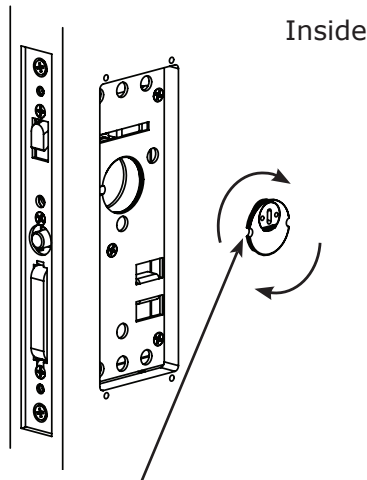

Inside

Note: Notch on cylinder must be in the 9 o'clock position when fully screwed into lock body.

3. Mount Inside Plate

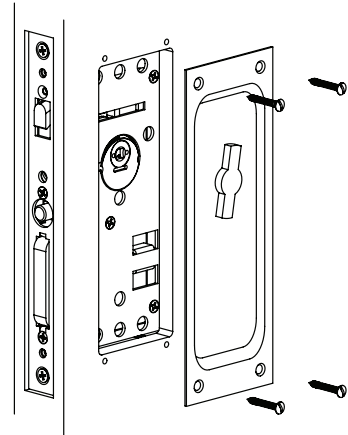

4. Mount Outside Plate

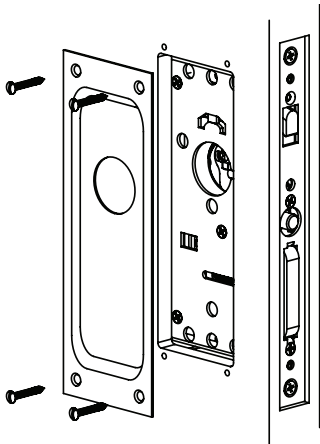

5. Thread Key Cylinder

Install Key Cylinder by threading it clockwise onto lock body plate

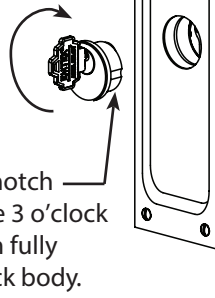

Key Cylinder notch must be at the 3 o'clock position when fully screwed in lock body.

6. Tighten Drive Bar Cylinder

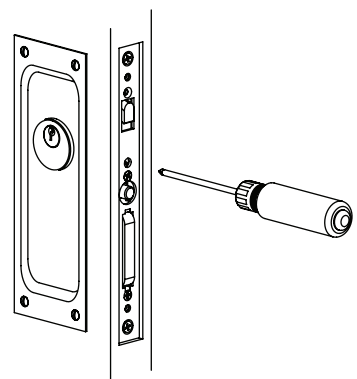

Tighten locking screw to engage notch on cylinder

7. Install Trim Plate

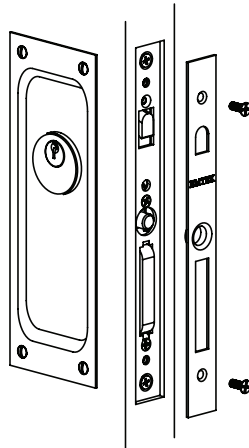

8. Install Door Jamb

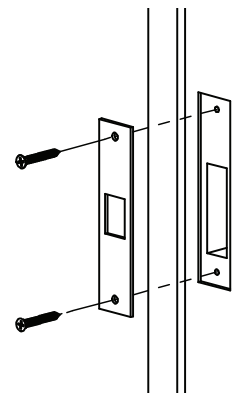

Drill two 7/64" pilot holes

See template for door jamb prep specifications

1. Install Lock Body

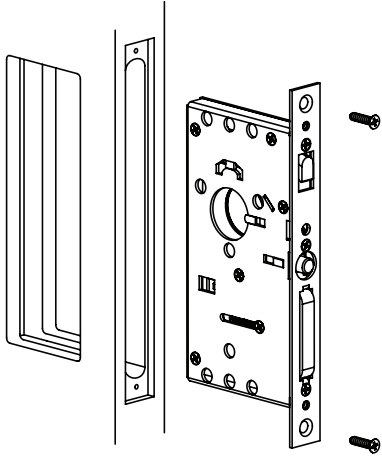

See template for door prep specifications

2. Install Drive Bar Cylinder

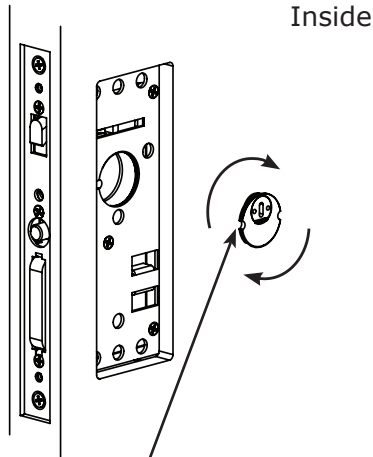

Note: Notch on cylinder must be in the 9 o'clock position when fully screwed into lock body.

3. Mount Inside Plate

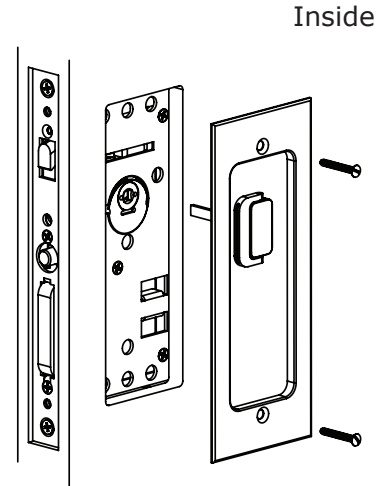

4. Mount Outside Plate and Thread Key Cylinder

Install Key Cylinder by threading it clockwise onto lock body plate

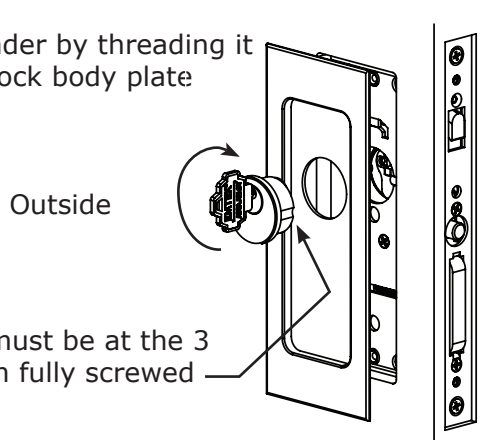

Key Cylinder notch must be at the 3 o'clock position when fully screwed in lock body.

5. Tighten Drive Bar Cylinder

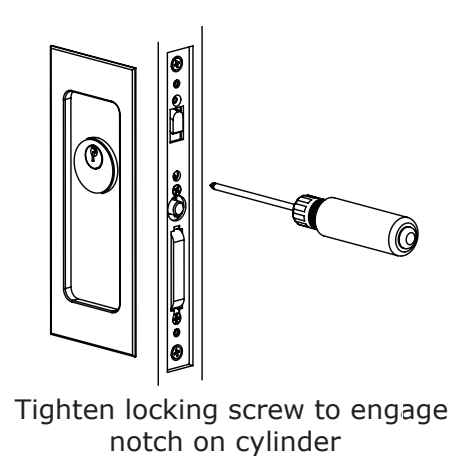

6. Install Trim Plate

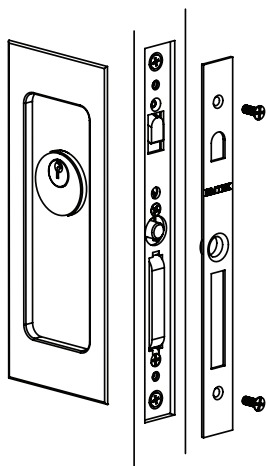

7. Install Door Jamb

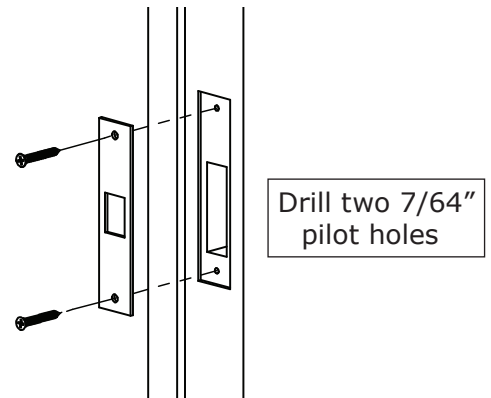

Drill two 7/64" pilot holes

See template for door jamb prep specifications

1. Install Lock Body

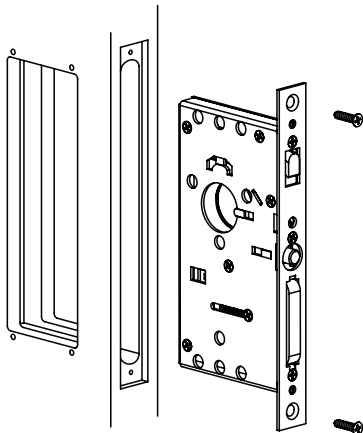

See template for door prep specifications

2. Install Drive Bar Cylinder

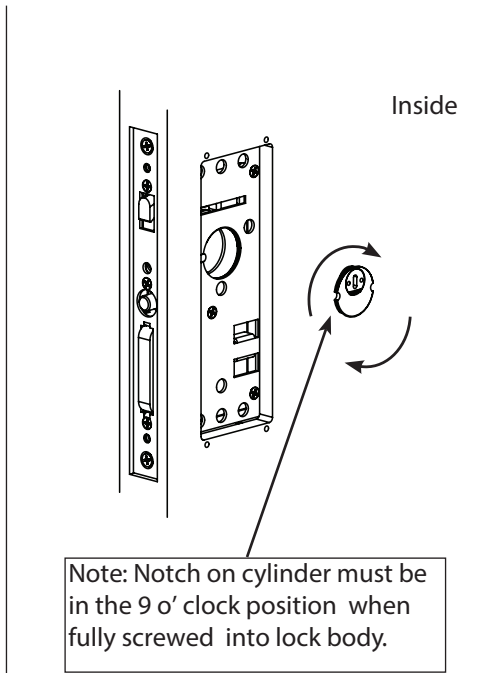

Note: Notch on cylinder must be in the 9 o'clock position when fully screwed into lock body.

3. Tighten Drive Bar Cylinder

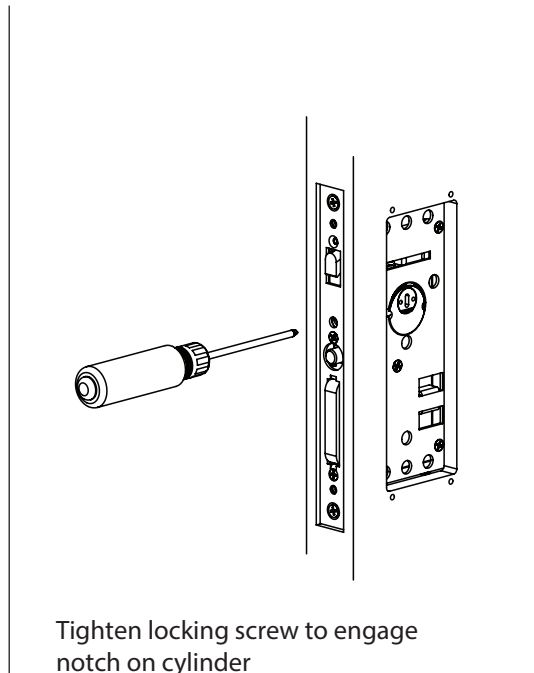

Tighten locking screw to engage notch on cylinder

4. Mount Inside/Outside Plates

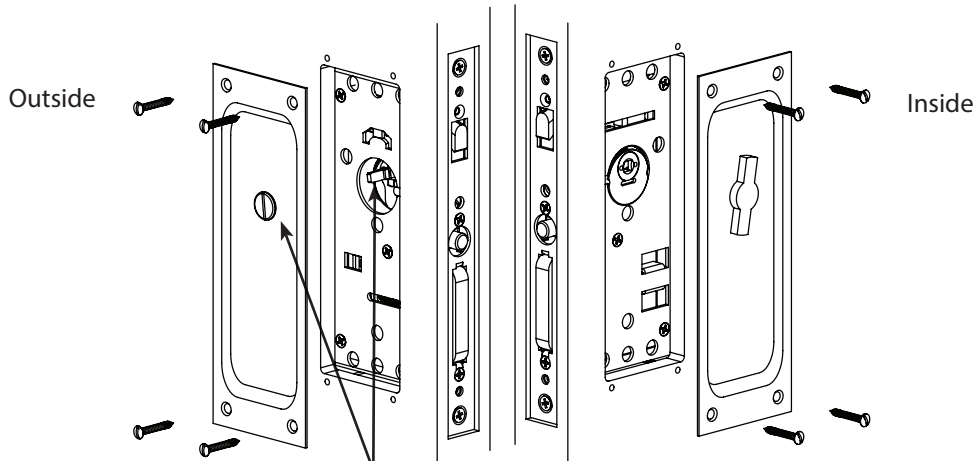

Align Passage/Privacy Button with Thumb-Turn spindle and secure trim plates to door.

5. Install Trim Plate

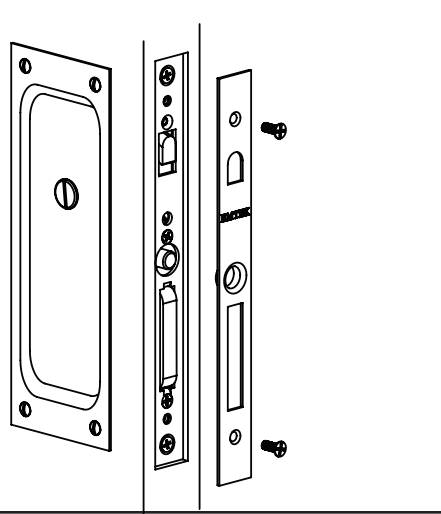

6. Install Door Jamb

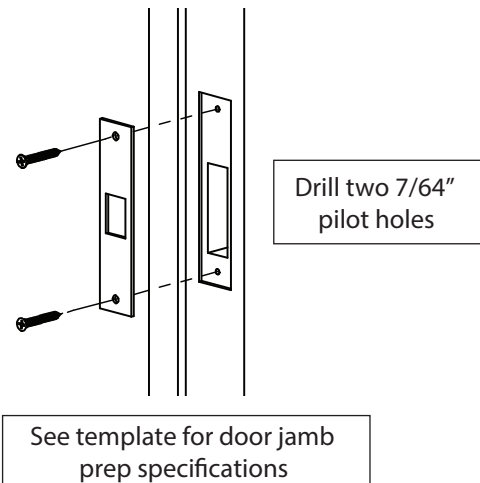

1. Install Lock Body

2. Install Drive Bar Cylinder

3. Tighten Drive Bar Cylinder

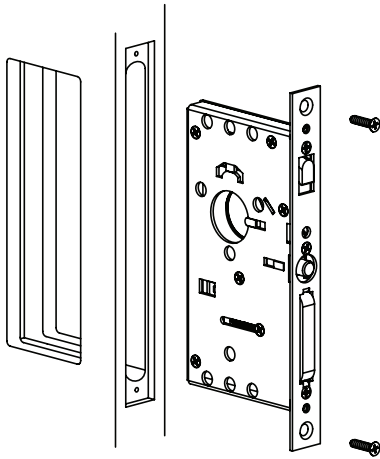

See template for door prep specifications

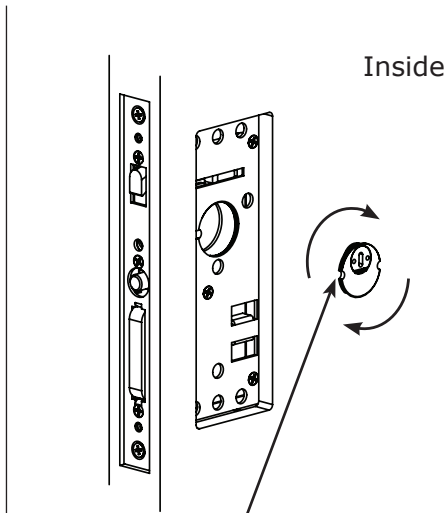

Note: Notch on cylinder must be in the 9 o'clock position when fully screwed into lock body.

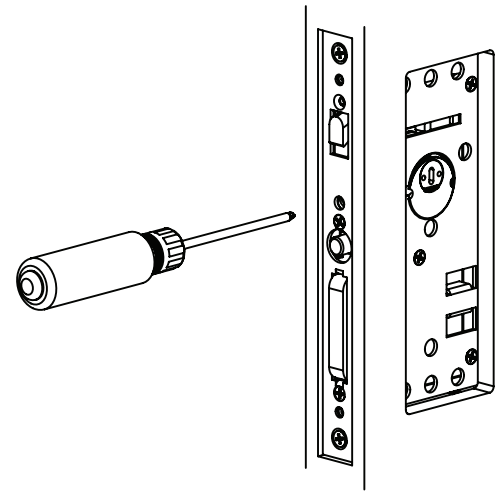

Tighten locking screw to engage notch on cylinder

4. Mount Inside/Outside Plates

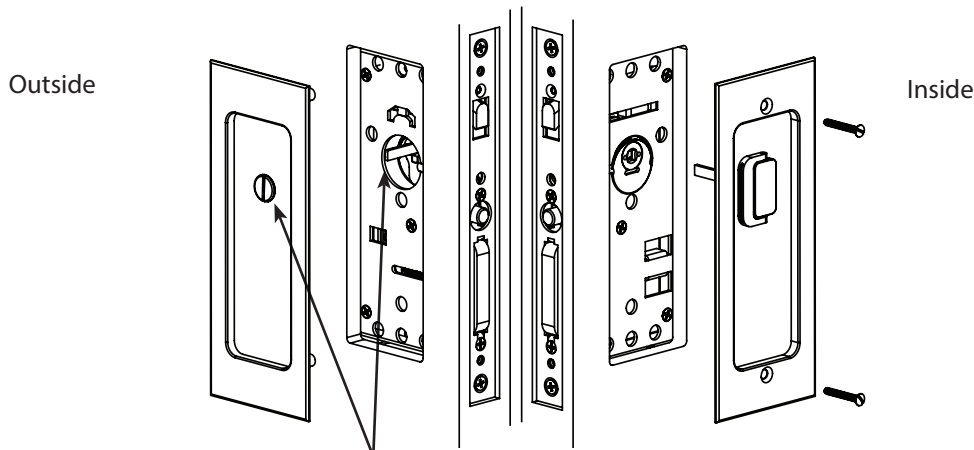

Align Passage/Privacy Button with Thumb-Turn spindle and secure trim plates to door.

5. Install Trim Plate

6. Install Door Jamb

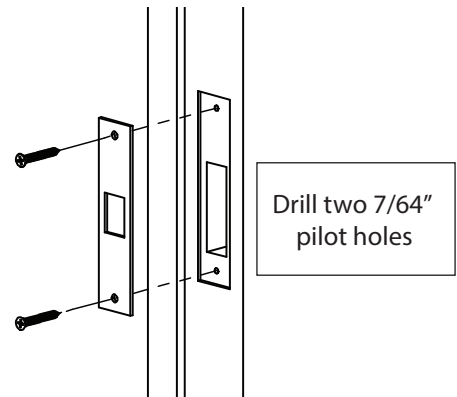
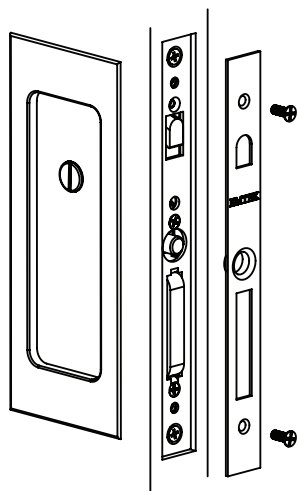

See template for door jamb prep specifications

1. Install Lock Body

2. Install Outside Plate

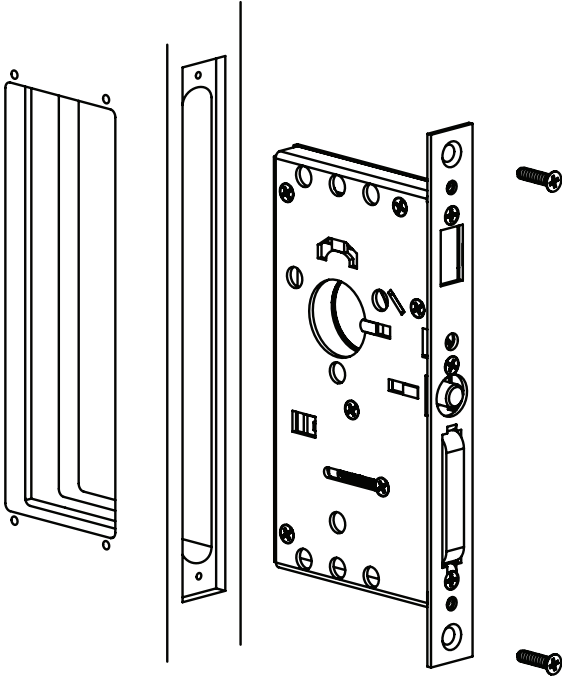

See template for door prep specifications

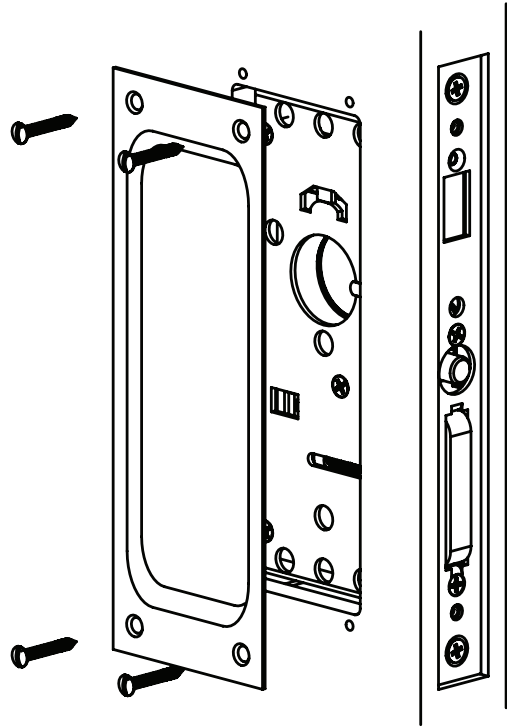

3. Install Inside Plate

4. Install Trim Plate

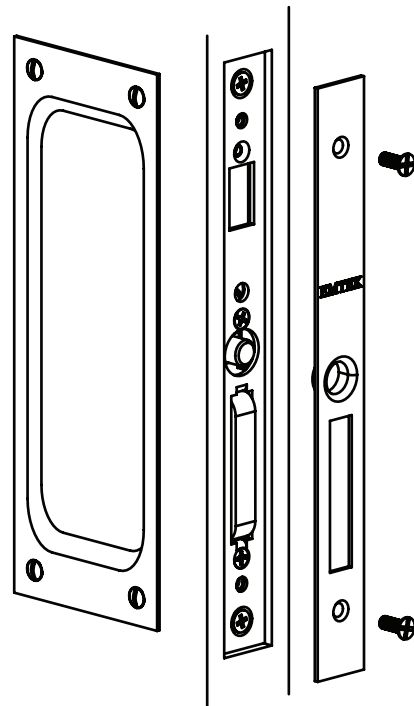
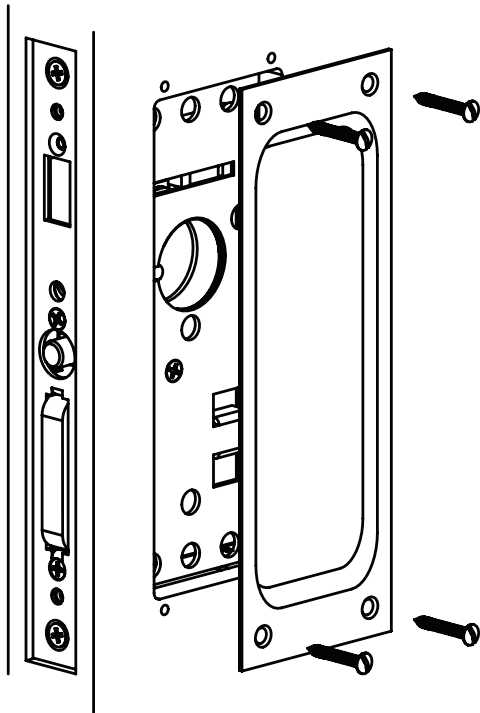

1. Install Lock Body

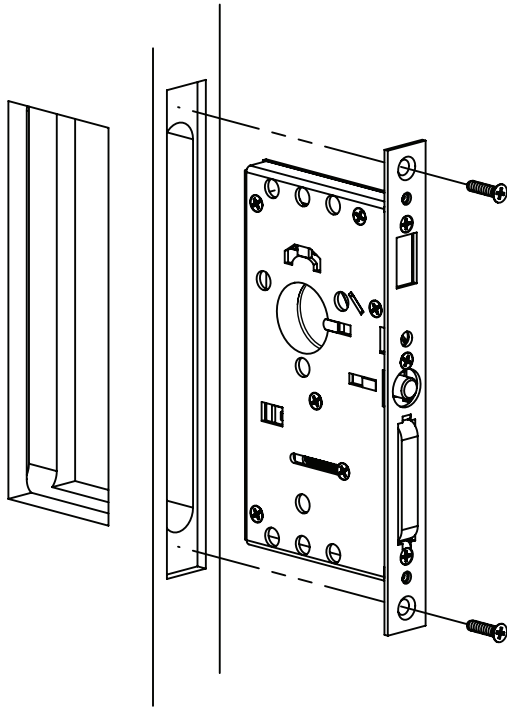

2. Hold Outside plate in place

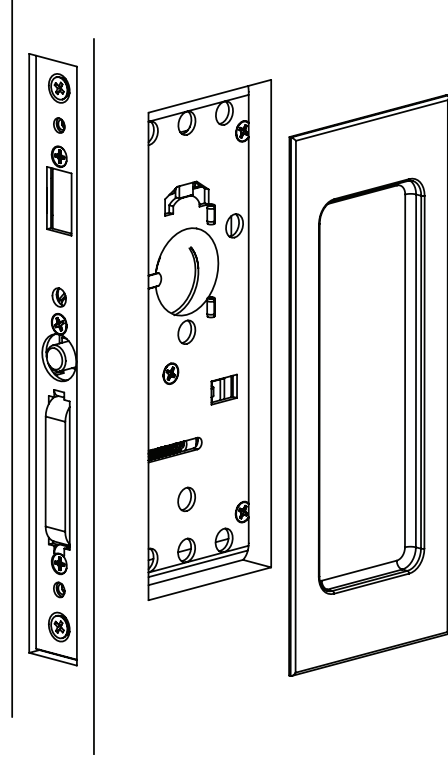

3. Secure both inside & outside Plates

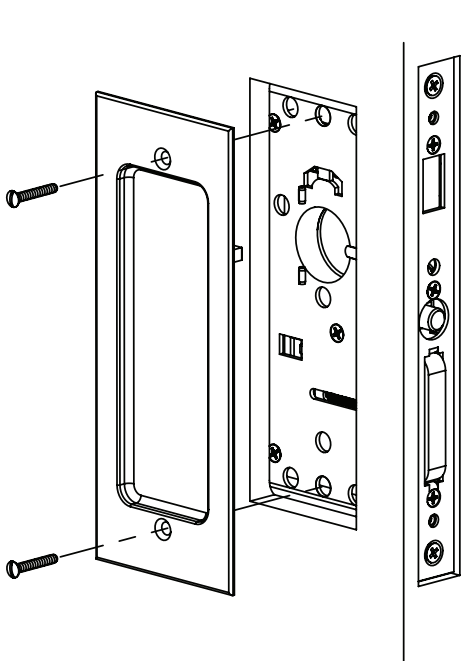

4. Install Trim Plates

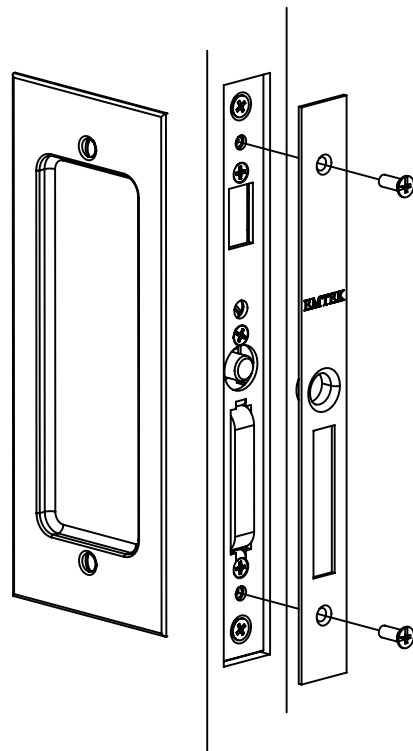

Secure both inside and outside plates using machine screws (provided)