

SUPER DECK Y-DSP SERIES GAS DISPLAY OVENS



Specifications

Bakers Pride Y-DSP Display Ovens are ideal for display cooking and exhibition kitchens. These ovens are designed and engineered to be "built-in" behind brick, stone or tile.

Ovens may be stacked two high. Ovens exteriors are all heavy-gauge steel and are fully insulated up to 5" (127mm) thick for cooler outer temperatures and consistent interior temperatures.

Interior oven frame is constructed of 1/4" (6mm) heavy-duty angle iron frame, completely welded to form a single, unitized section. The oven body and lining are then welded to the framework.

Oven interiors are manufactured of high-heat resistant 16-gauge aluminized steel. Doors are fully insulated, spring balanced with natural black finish and custom wood handles.

Lintel plates support the masonry or tile for ease of installation. Standard features include dome top plus front and side skirts.

All models feature independent, operator-controlled top & bottom heat control dampers and micro slides for perfectly balanced results.

Combination gas control incorporates a manual gas valve, pilot safety and pressure regulator. Easily removable, slide-out, heavy-duty flame diverters distribute the burner flame uniformly in the burner chambers. A 3/4" (19mm) NPT gas connection is located on the left side and left rear of oven – operator/installer may choose.

Heavy-duty, 7-gauge hot rolled steel legs are standard and finished with durable Bakertone.

2 Year limited warranty standard

Standard Features

- Y Series at 120,000 BTUH per deck, natural or LP gas
- 300°-650°F (149° - 343°C) thermostat
- Top and bottom heat control dampers & micro-slides
- Combination gas controls with valve, regulator & pilot safety
- Heavy-duty, slide-out flame diverters
- 8" (203mm) interior deck heights with 2" (50.80mm) thick Fibrament hearth decks
- Black powder coated doors
- Custom hardwood handles
- Dome top
- Front & side skirts
- Aluminized steel interiors
- Spring balanced, fully insulated doors
- Rear gas connections
- 7-Gauge legs
- Fully insulated throughout
- 2 Year limited warranty

Options & Accessories

- Side-mounted controls
- Steel decks
- 150°-550°F (65°-288°C) thermostat
- Automatic oven starter
- Draft flue for direct vent (non available on CE units)
- Without dome
- All stainless steel exterior with stainless steel dome & stainless steel or black powder-coated doors

Certifications



SUPER DECK Y-DSP SERIES GAS DISPLAY OVENS

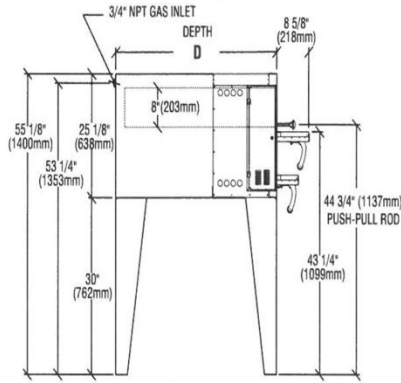

LEFT SIDE VIEW
Single Unit With Side Controls

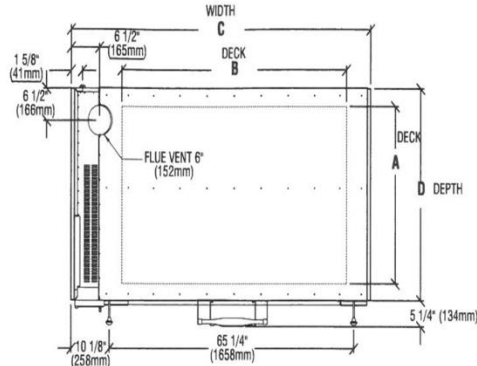

TOP VIEW

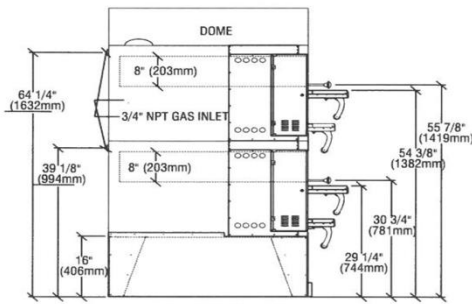

LEFT SIDE VIEW
Stacked Unit With Side Controls

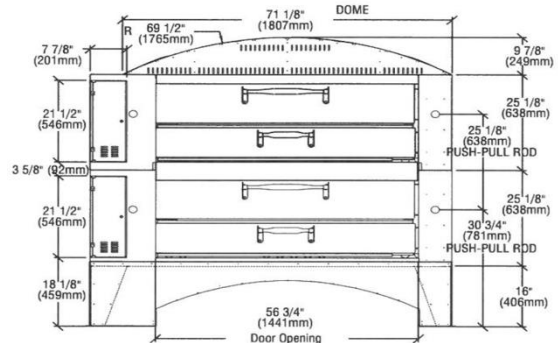

FRONT VIEW
Stacked Unit With Front Controls

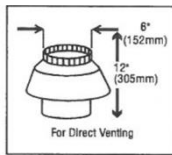

MUST BE SPECIFIED AT TIME OF ORDER

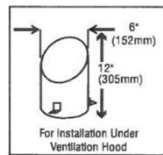

STANDARD

SHIPPING INFORMATION

Model	Shipping Weight		Carton Dimensions				Crate Size	
	Lbs.	Kilos	Width Inches	mm	Depth Inches	mm	Height Inches	mm
Y-600-DSP	1385	626	31	787	53	1364	82	2083
Y-800-DSP	1600	726	31	787	60	1365	86	2184

Each oven ships separately
Hearth Decks and Legs ship in separate cartons

GAS SUPPLY

Model	BTUH	KW	CONNECTION
Y-600-DSP	120,000	35.15	3/4"
Y-602-DSP	240,000	70.30	3/4"
Y-800-DSP	120,000	35.15	3/4"
Y-802-DSP	240,000	70.30	3/4"

CE certification not available in LP gas
Each deck requires a separate gas connection

SPECIFICATIONS

Model	Deck Sizes		# Decks	Overall Dimensions					
	A x B	mm		Inches	mm	Inches	mm		
Y-600-DSP	36 x 60	914 x 1524	1	78	1981	43	1092	55 1/8	1400
Y-602-DSP	36 x 60	914 x 1524	2	78	1981	43	1092	66 1/4	1683
Y-800-DSP	44 x 66	1118 x 1676	1	84	2134	51	1295	55 1/8	1400
Y-802-DSP	44 x 66	1118 x 1676	2	84	2134	51	1295	66 1/4	1683

MINIMUM CLEARANCES

	Noncombustible Construction		Combustible Construction	
	Inches	mm	Inches	mm
Right	0	0	1	25
Left	0	0	3	76
Rear	2	51	3	76