



COMPETITOR SERIES®

PROJECT: _____
 LOCATION: _____
 ITEM#: _____
 QUANTITY: _____



C-U27F



C-U48F



C-U60F

UNDER-COUNTER/WORK TOP FREEZERS

- Beautiful ergonomic construction & rounded corners
- Electro-mechanical thermostat with thermometer read-out. (Mid Year 2015: Digital temperature controller & read out)
- All stainless steel exterior and interior
- Forced air refrigeration system
- Recessed door handles
- Pre-installed casters and shelving
- 90 degree hold open door feature for loading products
- Optional Accessory: Backsplash for Work-Tops for in-the-field installment
- Migali® Protection Plan: 1 Year Parts & Labor Warranty, 5 Years Compressor Warranty

MODEL	DOORS	CU/FT	SHELVES	H/P	AMPS	VOLTAGE	WEIGHT(lbs)	ENERGY CONSUMPTION Kwh/24hr	PLUG TYPE	DIMENSIONS L x D x H	TEMPERATURE RANGE
C-U27F	1	6.5	1	1/4	4.4	115/60/1	195 lbs.	3.4	Nema 5-15P	27.5" x 30" x 36.5"	-7° F (-) 3° F
C-U48F	2	12	2	1/3	6.5	115/60/1	244 lbs.	6.5	Nema 5-15P	48.2" x 30" x 36.5"	-7° F (-) 3° F
C-U60F	2	18.2	2	1/2	6.5	115/60/1	302 lbs.	6.6	Nema 5-15P	60.2" x 30" x 36.5"	-7° F (-) 3° F

* MIGALI® RESERVES THE RIGHT TO CHANGE SPECIFICATIONS WITHOUT NOTICE

* TOTAL HEIGHT INCLUDES CASTERS



TOLL FREE: 800.852.5292

WEB: www.migali.com



MIGALI® REMAINS AN AMERICAN FAMILY COMPANY SINCE 1955

DIMENSIONAL DRAWINGS

C-U27F

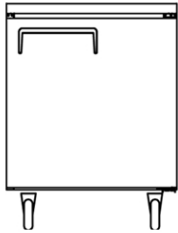

C-U48F

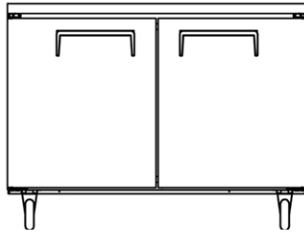

C-U60F

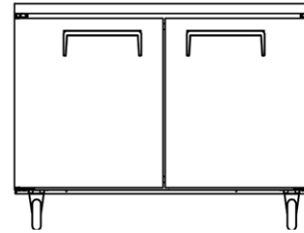

C-U27F TOP VIEW

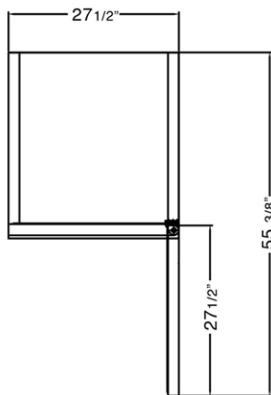

C-U48F TOP VIEW

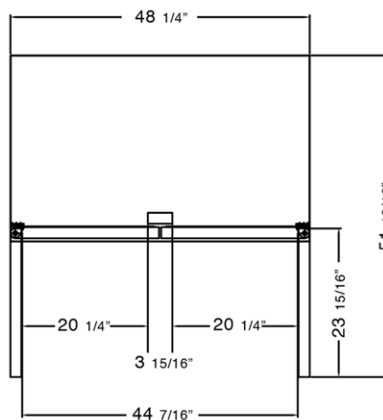

C-U60F TOP VIEW

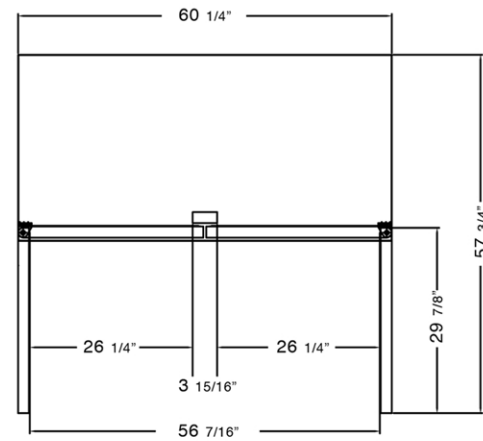

SIDE VIEW (1,2,3) DOORS MODELS

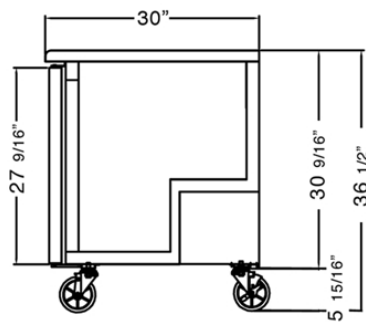

TOLL FREE: 800.852.5292
FAX: 856.963.3604
EMAIL: contact@migali.com
WEB: www.migali.com



MIGALI® REMAINS AN AMERICAN FAMILY COMPANY SINCE 1955