

PROJECT:	_____
LOCATION:	_____
ITEM#:	_____
QUANTITY:	_____

**COMPETITOR SERIES®**

**C-23FM**

**C-49FM**

**C-72FM**

# HINGED GLASS DOOR FREEZERS

- Beautiful ergonomic construction
- Digital temperature controller & read-out
- White powder coated steel exterior and interior
- Forced air refrigeration system
- Bottom mount compressor
- Recessed door handles
- LED interior lighting
- Bright lighted top display sign
- Low-E, Triple pane heated glass
- Heavy duty ABS extruded door frame
- Pre-installed casters and shelving
- 90 degree hold open door feature for loading products
- Door locks
- Migali® Protection Plan: 1 Year Parts & Labor Warranty, 5 Years Compressor Warranty

MODEL	DOORS	Cu/Ft	SHELVES	H/P	AMPS	VOLTAGE	WEIGHT(lbs)	ENERGY CONSUMPTION Kwh/24hr	PLUG TYPE	DIMENSIONS L x D x H	TEMPERATURE RANGE
C-23FM	1	23	4	1/2	7.5	115/60/1	265 lbs.	10	Nema 5-15P	27" x 31.5" x 81"	-10° F (-) 0° F
C-49FM	2	49	8	3/4	12	115/60/1	419 lbs.	12	Nema 5-15P	54.4" x 31.5" x 81"	-10° F (-) 0° F
C-72FM	3	72	12	1 & 1/2	9.6	208-230/115/60/1	630 lbs.	14.4	Nema L14-20P	82" x 31.5" x 81"	-10° F (-) 0° F

\* MIGALI® RESERVES THE RIGHT TO CHANGE SPECIFICATIONS WITHOUT NOTICE

\* TOTAL HEIGHT INCLUDES CASTERS



**TOLL FREE: 800.852.5292**  
**WEB: www.migali.com**



Conforms to NSF 7 Foodservice

**MIGALI® REMAINS AN AMERICAN FAMILY COMPANY SINCE 1955**

# DIMENSIONAL DRAWINGS

**C-23FM**

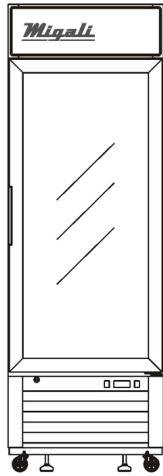

**C-49FM**

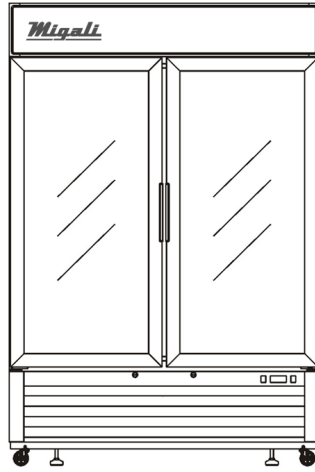

**C-72FM**

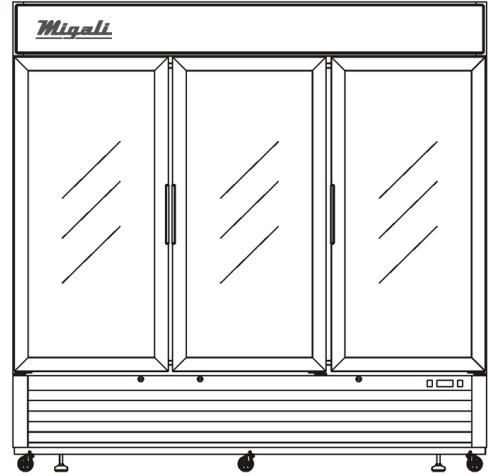

**C-23FM TOP VIEW**

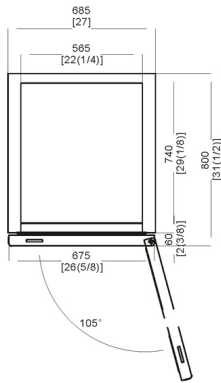

**C-49FM TOP VIEW**

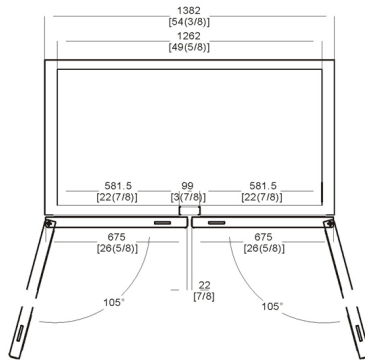

**C-72FM TOP VIEW**

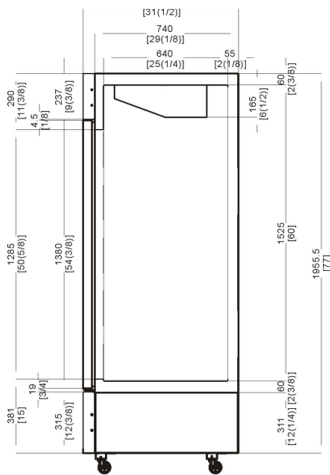
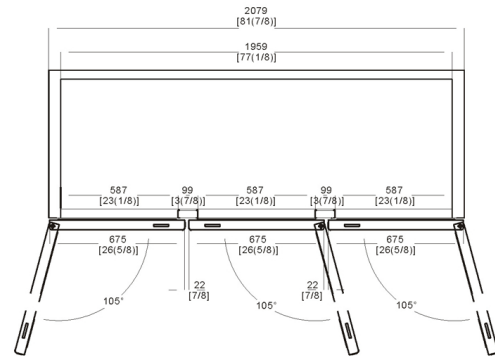

**SIDE VIEW (1,2,3) DOORS MODELS**

**TOLL FREE:** 800.852.5292

**FAX:** 856.963.3604

**EMAIL:** contact@migali.com

**WEB:** www.migali.com



MIGALI® REMAINS AN AMERICAN FAMILY COMPANY SINCE 1955