

MODEL: IRT-UC27P
UNDERCOUNTER:
Sandwich / Salad Prep Tables.

General Strengths

- ✓ **Sanitation.** The interior cabinet is built with rounded corners (extensive radius for easy cleaning). Easy removal off shelves and slides for interior cleaning. Each cabinet has a drain at the bottom of the unit. When cleaning the unit make sure the drain hose is routed to a floor drain.
- ✓ **Doors.** Self-closing door system with permanent pressure. Stay open feature included when door remains open after 95 degrees. All doors and drawers include triple chamber door gaskets, easy to remove and snap in. Doors are field reversible. Parts not included.
- ✓ **Control systems.** Greater ability for the adjustment temperature ranges as per the end user's requirements.
- ✓ **100% Tested.** All condenser units are 100% tested, in helium chambers for refrigerant leak detections.
- ✓ **Certified.** Audited and Certified by **INTERTEK** for compliance with UL 471 and NSF 7. AENOR audited and certified by internationally recognized firm. ISO 9001:2015 (Quality); ISO 14001:2015 (Environmental); OSHAS 18001:2007 (Prevention and Worker Safety)



Revision: 04 Date: 03/05/2019 IRT-UC27P_FT_62_4

MODEL	Dimensions (inches) (mm)			Nº Doors/Pans	Nº Shelves / Slides	Ref.	Ref. Weight (Lbs.) (gr.)	Temp. Range (°F) (°C)	Capacity (Cu. Ft.) (L)	Cond. Unit. H.P.	Case Amps 115 V.	Crated Weight (Lbs.) (Kg.)
	W	D	H									
IRT-UC27P	27-3/4	31-1/4	47-1/4	1 / 8	2 / 2	R290	0.24	35°F/41°F	8	1/4	3.9	300
	700	795	1200									

FTL LISTED TO UL471 STANDARD AND SANITATION CLASSIFIED TO NSF7 - WE RESERVE THE RIGHT TO CHANGE SPECIFICATIONS WITHOUT PRIOR NOTICE

MODEL: IRT-UC27P

UNDERCOUNTER:
Sandwich / Salad Prep Tables.

STANDARD FEATURES

➤ **Exterior**

- AISI 430 Stainless Steel,
- AISI 304 Stainless Steel Top.

➤ **Interior**

- AISI 430 Stainless Steel.

➤ **Doors**

- Polyurethane insulated door,
- Self-closing door with stay open feature,
- Stainless Steel heavy-duty hinges,
- Triple chamber snap in door gaskets for easy removal and cleaning,
- Field reversible door, parts not included,
- Full-height door opening: 23-1/4"x21-7/8" (590x555 mm).

➤ **Insulation**

- CFC-Free polyurethane insulation, entire cabinet structure is foamed-in using a high-density polyurethane insulation,
- Low GWP & Zero ODP effect.

➤ **Casters**

- 4" diameter casters,
- Locks provided on front set.

➤ **Salad Top**

- Stainless Steel insulated lid,
- Top includes 1/6 size polycarbonate food pans (8 pans),
- Pan divider bars included for varying size pan configurations,
- Removable sanitary polyethylene cutting board included.

➤ **Shelving**

- (2) Two plastic coated wire shelves,
- Set of Stainless Steel shelf brackets,
- Easy removal for cleaning,
- Dimensions WxD: 22-1/4"x17" (565x432 mm).

➤ **Refrigeration**

- Temperature regulated by thermostatic control,
- Stainless Steel evaporative pan,
- Evaporator coil coated with anti-corrosion material 100% Polyester,
- Forced air refrigeration system,
- Refrigeration capacity: 867 Btu/h (14[°]F) / 254 W (-10[°]C).

➤ **Electrical**

- 20-amp breaker required,
- Cord and NEMA 5-15P plug.
- Electrical connection is 115V / 1ph / 60 Hz.



➤ **ETL Listed to UL471 Standard and Sanitation classified to NSF7.**

OPTIONAL FEATURES

- ✓ Electrical connection is: 220-230 V / 1ph / 50 Hz (plug type varies).
- ✓ Flat lid,
- ✓ Single Overshelf,
- ✓ Double Overshelf,
- ✓ Set of 2" diameter casters, with lock provided on front set,
- ✓ Drawer kit: 27-1/8"x20"x12-5/8" (689x509x320 mm).

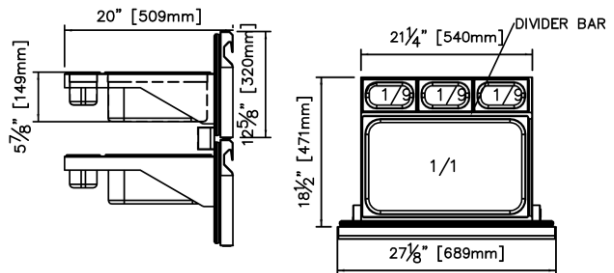

Revision: 04 Date: 03/05/2019 IRT-UC27P_FT_62_4

ETL LISTED TO UL471 STANDARD AND SANITATION CLASSIFIED TO NSF7 - WE RESERVE THE RIGHT TO CHANGE SPECIFICATIONS WITHOUT PRIOR NOTICE



Infrico USA Corp.
1409 N.W. 84th Avenue
Doral, FL 33126
1.305.777.9599 Office
1.305.777.9598 Fax

www.infrico.us
sales@infrico.com

APPROVALS: _____ **AVAILABLE AT:** _____

MODEL: IRT-UC27P

UNDERCOUNTER:
Sandwich / Salad Prep Tables.

PLAN VIEW

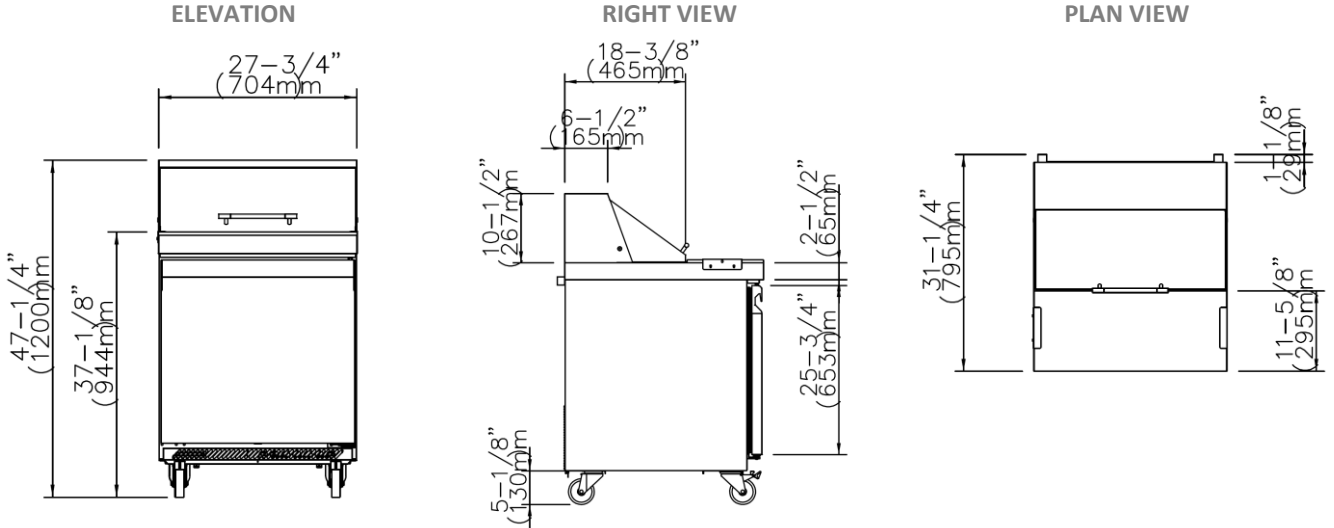

Revision: 04 Date: 03/05/2019 IRT-UC27P_FT_62_4

ETL LISTED TO UL471 STANDARD AND SANITATION CLASSIFIED TO NSF7 - WE RESERVE THE RIGHT TO CHANGE SPECIFICATIONS WITHOUT PRIOR NOTICE



Infrico USA Corp.
1409 N.W. 84th Avenue
Doral, FL 33126
1.305.777.9599 Office
1.305.777.9598 Fax

www.infrico.us
sales@infrico.com

APPROVALS: _____ AVAILABLE AT: _____