

FOTILE

A BREATH OF FRESH ENGINEERING®

Contact Information:

FOTILE AMERICA LLC.

Add: 6 Campus Dr, Suite 210, Parsippany, NJ 07054

Toll Free: 888-315-0366

Web: us.fotileglobal.com

Media Inquiries: marketing@fotile.com

Customer Support: serviceusa@fotile.com

FOTILE



A BREATH OF FRESH ENGINEERING®



FOTILE Website



FOTILE Wechat



FOTILE YouTube

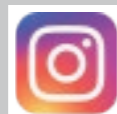

FOTILE_America



NKBA
NATIONAL
KITCHENBATH
ASSOCIATION



Member of HVI, the most
authoritative and credible
institution in North America



reddot



product
design award



Intertek

RANGE HOODS | COOKTOPS | IN-SINK DISHWASHERS | CONVECTION OVENS | STEAM OVENS

ENHANCING YOUR HOME THROUGH INNOVATION

- ◆ Innovation is the core of FOTILE manufacturing
- ◆ More than 4,100 national patents including over 580 invention patents (Dec 2020)
- ◆ Leader in kitchen appliances, FOTILE never stops innovating



GET TO KNOW FOTILE

For more than 24 years, FOTILE is always exceeding kitchen expectations in all around the globe, supporting a happy, healthy lifestyle for families like yours. Currently, FOTILE has 117 sales branches, and FOTILE products are available for purchase in home appliance chains, department stores, exclusive FOTILE stores, and online.

In 2016, FOTILE America established its headquarters in Parsippany, New Jersey. Since then, FOTILE products are available to US consumers through our carefully-selected FOTILE Chartered Agents.

With a brand that's worth \$2.8 billion, FOTILE is more than a kitchen appliance company; we're an industry leader, and the #1 choice among consumers in over 30 different countries. By December 2020, FOTILE holds over 4,100 patents including over 580 invention patents.

Our dedication to ongoing research and development has allowed FOTILE to proudly create innovative technology products, raising the standards for premium built-in kitchen appliances.

Our mission is simple: For the happiness of hundreds of millions of families.

us.fotileglobal.com

FOTILE America LLC

FOTILE America was formed in 2016, based in Parsippany New Jersey, FOTILE also has operating offices in Los Angeles and Houston and is rapidly growing. Becoming a member of the National Kitchen & Bath Association (NKBA) and partnering with the Home Ventilating Institute (HVI), FOTILE has established a well-trusted brand with great ventilation technologies and innovative products. FOTILE currently has over 100 dealers located in major cities in the following states: New York, New Jersey, Pennsylvania, California, Georgia, Florida, Illinois, Maryland, Washington, Massachusetts, Washington, D.C., Texas, etc. FOTILE also actively partners with U.S. major home appliance retailers, including The Home Depot, Lowe's, P.C. Richard & Son, Appliance Connection, etc.

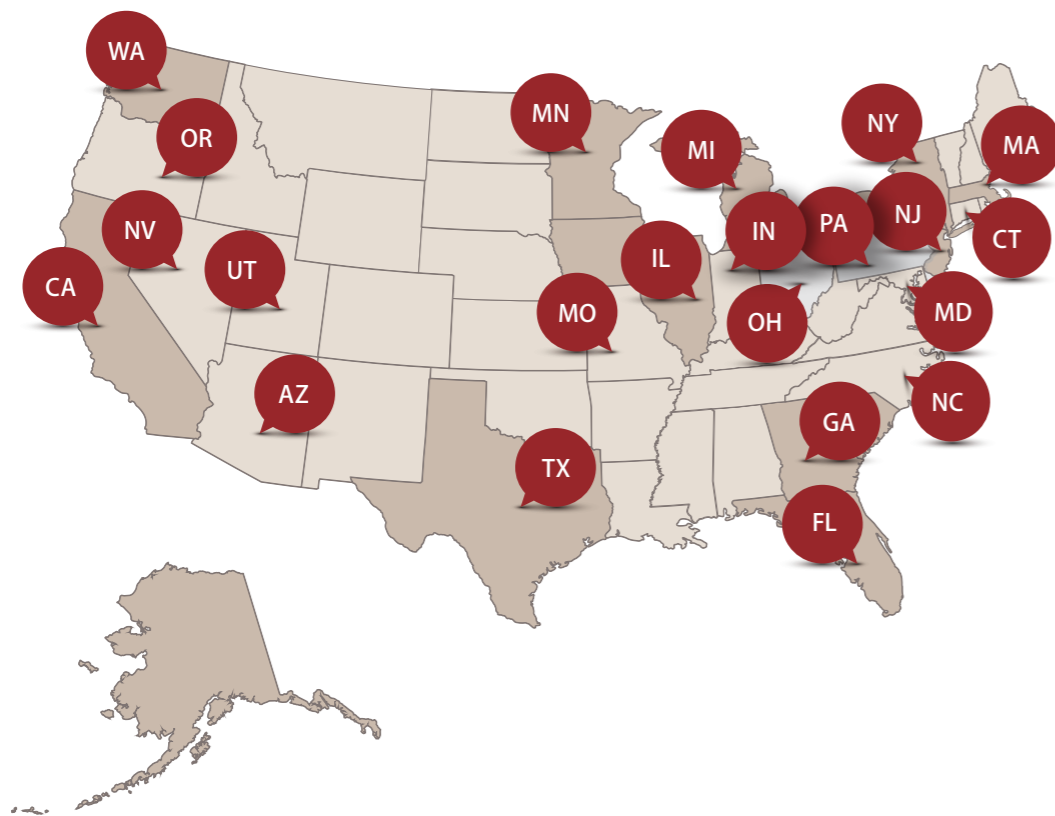

Founded in 1996
5.8 million sq.ft.
Corporate Headquarters



16,000+ Employees,
4 factories,
116 branch offices

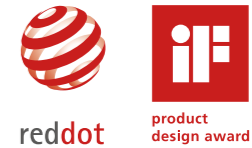

Winner of nearly **50**
Design awards



Sales in over **30+**
countries

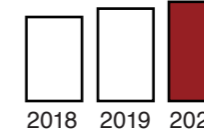

The sales scale
exceeded **\$1.9 billion**
for 3 consecutive years
(2018-2020)



≥ 5% total revenue is
reinvested
back into R&D



86,000 sq.ft.
R&D Facility



43.4%
Chinese high-end
Market Share



Nearly **4100** Patents
580 invention patents.
Leading in the industry

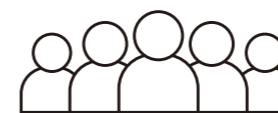

Choice of Appliance for over
17 Million families

In the News



us.fotileglobal.com



FOTILE

Pixie Air™ Series

FOTILE Pixie Air™ features the brand's most quiet range hood that is able to provide strong ventilation power at the same time.



Model: **UQS3001**



Model: **UQG3002**

Featuring WhisPower technology, the motors of Pixie Air™ Series range hoods are more powerful and operates with minimal noise due to lower resistance and better air flow. The two Capture Shields utilize Coanda effect to maximize extraction power and whisk away smoke, steam, and grease more efficiently.

3.0 Capture Shield Technology

Effortlessly Eliminates Smoke and Grease with Minimal Sound

The Pixie Air™ is FOTILE's solution to the common problem with under cabinet range hoods - poor ventilation. FOTILE engineers have gone through thousands of experiments in the R&D lab to develop the 3.0 Capture Shield Technology. Its Capture Shield Technology creates a Coanda Effect guiding smoke and grease directly into the range hood. This process is what leads Pixie Air™'s superior performance to quickly capture smoke while utilizing high efficiency oil filtration.



Capture Shield Technology

Covers a 30" cooktop surface or 6 sq. ft. of cooking space



18mph ultra fast fume intake

Extreme Coanda effect speeds up the extraction process



Integrated Oil Collection Cup

Cleaning the Pixie Air™ is very easy. Simply remove the Capture Shields with integrated oil cups and wipe them clean with a towel and mild dish soap.

WhisPower System

High suction power and low noise levels have always been viewed by the industry experts as opposing forces that are difficult to balance. FOTILE's engineers have innovated and developed the WhisPower System, marking a revolutionary innovation. With the WhisPower System, there is no need to compromise on powerful performance. FOTILE has created a range hood that has superior powerful performance, without the loud noise. Now you can prepare your favorite meal while having a casual conversation or listening to music.



850 CFM*

Enabling the entire kitchen to be refreshed in just 1.5 minutes.

* UQG3002: Equivalent to 850 CFM | UQS3001: Equivalent to 800 CFM



Two Motors, Deliver More Power

Twin-turbine centrifugal fans covering a 30-inch cooking area provide a constant flow of suction power.



Super Quiet Operation, as low as 37dB

The FOTILE Pixie Air™ has quiet operation, allowing you to have a casual conversation while cooking, or listening to your favorite music.

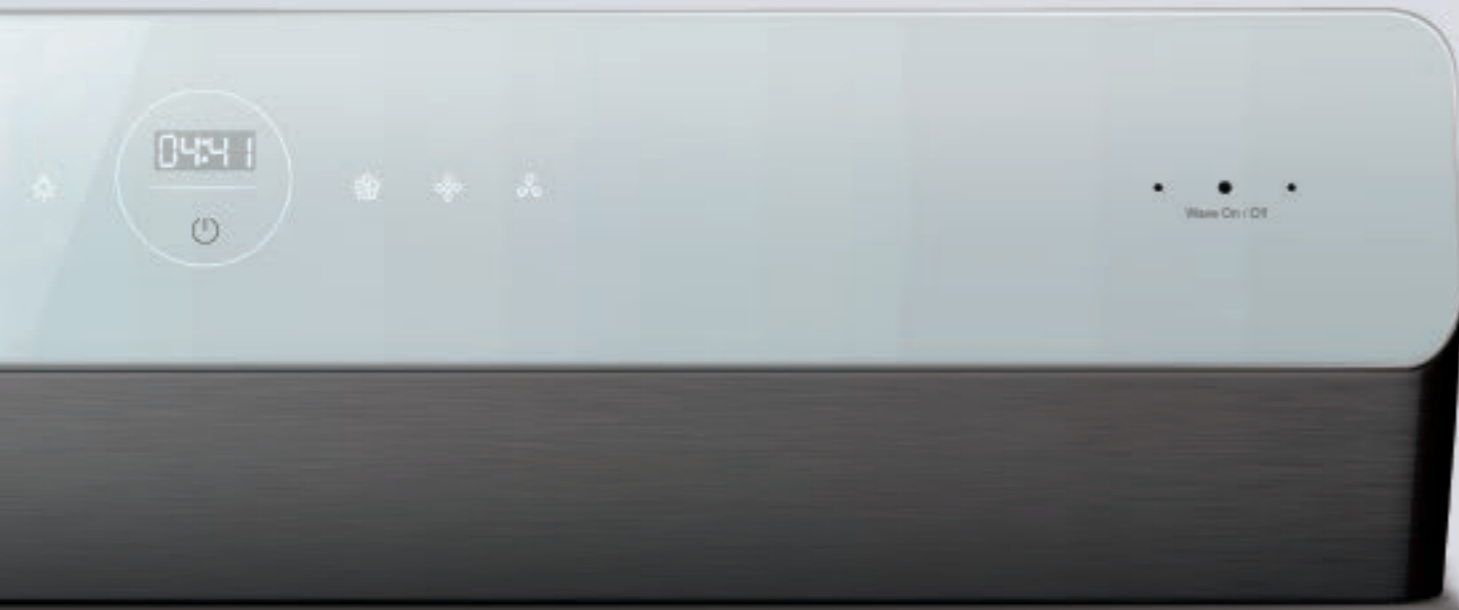

Model: UQG3002

FOTILE Pixie Air™ Series

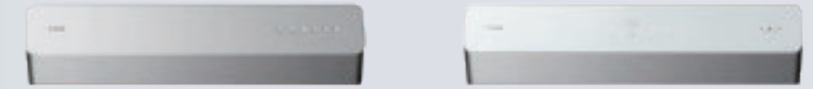

Model	UQS3001	UQG3002	
Size (inch)	Width	29 13/16	29 13/16
	Depth	22 1/16	22 1/16
	Height	8 5/16	8 5/16
Installation	Under-Cabinet	Under-Cabinet	
Duct Type	Horizontal/Vertical	Horizontal/Vertical	
Power Supply	120V/60Hz	120V/60Hz	
Input Power	256W	260W	
Max. Static Pressure(Pa)	350	400	
Max. EQUIV. CFM	800	850	
Min. Noise Level(dB)	37	37	
Speed Setting	3	4	
Illumination	Power	3W × 2 (LED)	3W × 2 (LED)
	Night Mode	N	Y
Motor	Dual AC Motors	Dual AC Motors	
Capture Shield	3.0 w/ One-Piece Grease Tray	3.0 w/ One-Piece Grease Tray	
Operation	Push Buttons	Motion Activation + Touchscreen	
Delay Shutoff	N	5/15/30min	
Intelligent Air Management	Y	Y	

Detail is in Our Design



Motion Activation

Non-contact operation through motion gesture

(UQG3002 Only)



Intelligent Air Management System

Automatically detects and removes harmful gases for peace of mind



Multi-shift Delay Shutoff

Programmable auto delay shut-off, 5/15/30 min

(UQG3002 Only)



600LUX LED Lighting

LED Lighting brightens up your cooktop so you can see the color and texture of your food while you are cooking.

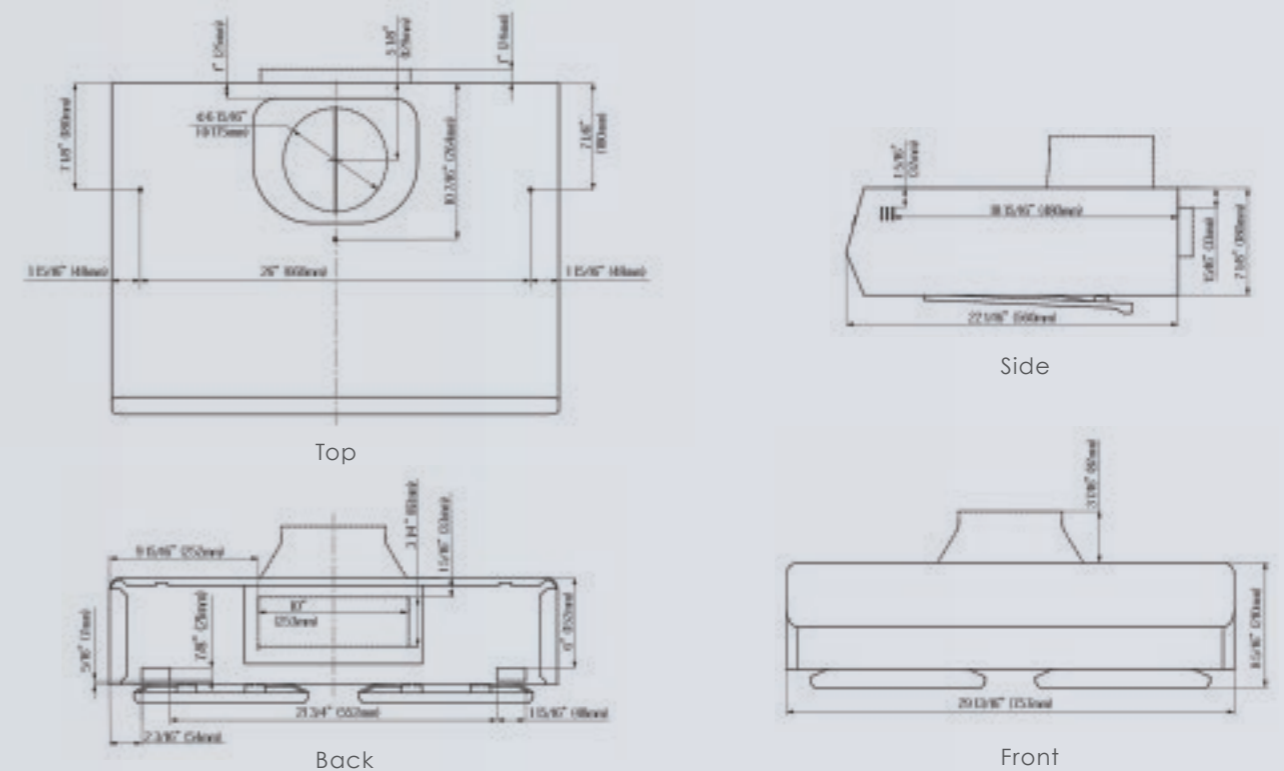

FOTILE

Slant Vent Series



Member of HVI, the most authoritative and credible institution in North America



reddot design award

FOTILE Slant Vent Series range hoods provide not only excellent performance, but looks great in any kitchen design. With closer proximity to the cooking surface, and the capture shield opening to 90 degree angle, the engineering of the range hood maximizes coverage area and extraction power, preventing you and your family from breathing in harmful smoke and grease.

FOTILE Slant Vent Series Range Hoods

Designed to keep up with the busiest home kitchens today!

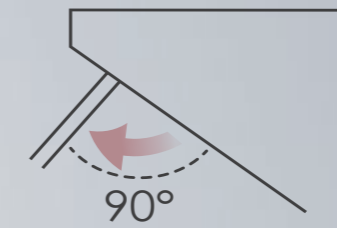

90° Degree Capture Shield

Opens automatically when the range hood is turned on, guiding smoke upwards and creating a barrier to prevent you from breathing in harmful smoke and grease.

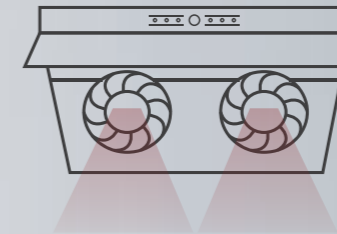

FOTILE's Proprietary Double Centrifugal Fan System

Closer proximity to the cooktop surface than traditional range hoods.

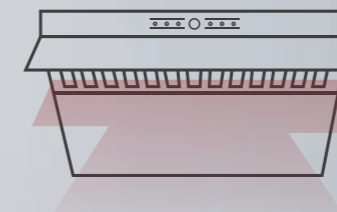

Extended Smoke Intake

Spanning evenly from side to side, FOTILE's range hood effectively covers every burner for a clean, smoke-free kitchen.

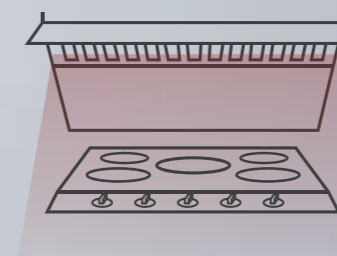

Expanded Coverage Area

The angled design of the side-draft range hoods provides a large ventilation area, proactively drawing in smoke and grease before they can spread. The 30-inch range hood provides coverage for an area measuring 6 square feet, while the 36-inch range hood boasts 7 square feet of coverage.

Everything You Need In A Range Hood



LED Lights

Easily navigate around your stove with up to 500 lux for improved visibility.

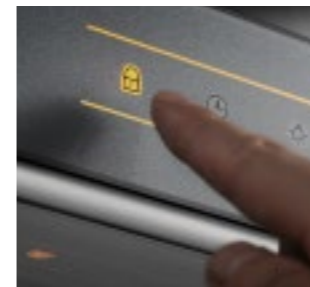

Screen Lock For Easy Cleaning

Hold down the LOCK SCREEN Button for 2 seconds to lock your screen so you can clean the range hood with a damp cloth.

Auto Delay Shutoff

Eliminate lingering smoke and other odors with your range hood's DELAYED SHUTOFF feature, keeping the fan on for an additional 2 minutes after you're ready to leave the kitchen.

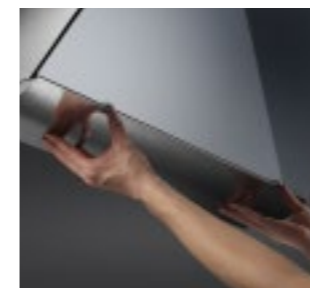

Extra-Large Oil Cup

Collects grease and oil while you are cooking. A large capacity collection cup requires less frequent cleaning.

Removable, Dishwasher-Safe Filter

Cleaning your filter is quick and easy, simply remove it from the range hood and place it in the dishwasher utilizing the convenient folding design.

FOTILE Slant Vent Series



A BREATH OF FRESH ENGINEERING®

Model	JQG7505	JQG9001
Certification	ETL,HVI	ETL,HVI
Product Dimensions (inch)	29 7/8(W) * 18 1/4(D) * 17 7/16(H)	35 7/8(W) * 18 1/4(D) * 17 7/16(H)
Max. EQUIV. CFM	1000	850
Power Supply	120V/60HZ	120V/60HZ
Input Power	210W	256W
Motor	Dual DC Motors	Dual AC Motors
Illumination(W)	3W × 2 (LED)	3W × 2 (LED)
Noise Level(dB)	38-56.5	39-54
Highest Static Pressure(Pa)	540Pa	400Pa
Speed Setting	Stir-Fry & High & Middle & Low	High & Middle & Low
Delay Shutoff	2min	2min
Oil Filtration Rate	95%	95%
Smell Reduction Rate	98%	98%
Color	Onyx Black	Onyx Black
Operation	Motion Activation + Touchscreen	Touchscreen
Capture Shield	Automatically Open to 90°	Automatically Open to 90°
Screen Lock	Y	Y
Oil Filter	Removable & Dishwasher Safe	Removable & Dishwasher Safe
Oil Cup	One Large Oil Cup	Two Oil Cups
Installation	Wall-Mount/Under-Cabinet	Wall-Mount/Under-Cabinet

	JQG7501	JQG7501.G
Certification	ETL,HVI	ETL,HVI
Product Dimensions (inch)	29 7/8(W) * 18 1/4(D) * 17 7/16(H)	29 7/8(W) * 18 1/4(D) * 17 7/16(H)
Max. EQUIV. CFM	850	850
Power Supply	120V/60HZ	120V/60HZ
Input Power	256W	256W
Motor	Dual AC Motors	Dual AC Motors
Illumination(W)	3W × 2 (LED)	3W × 2 (LED)
Noise Level(dB)	39-54	39-54
Highest Static Pressure(Pa)	400Pa	400Pa
Speed Setting	High & Middle & Low	High & Middle & Low
Delay Shutoff	2min	2min
Oil Filtration Rate	95%	95%
Smell Reduction Rate	98%	98%
Color	Onyx Black	Silver Grey
Operation	Touch Screen	Touch Screen
Capture Shield	Automatically Open to 90°	Automatically Open to 90°
Screen Lock	Y	Y
Oil Filter	Removable & Dishwasher Safe	Removable & Dishwasher Safe
Oil Cup	One Large Oil Cup	One Large Oil Cup
Installation	Wall-Mount/Under-Cabinet	Wall-Mount/Under-Cabinet

FOTILE Slant Vent Series



JQG9001/JQG7501/JQG7501.G/JQG7502/JQG7502.G/JQG7505

Unit: inch

Model	JQG7502	JQG7502.G
Certification	ETL,HVI	ETL,HVI
Product Dimensions (inch)	29 7/8(W) * 18 1/4(D) * 17 7/16(H)	29 7/8(W) * 18 1/4(D) * 17 7/16(H)
Max. EQUIV. CFM	850	850
Power Supply	120V/60HZ	120V/60HZ
Input Power	256W	256W
Motor	Dual AC Motors	Dual AC Motors
Illumination(W)	3W × 2 (LED)	3W × 2 (LED)
Noise Level(dB)	39-54	39-54
Highest Static Pressure(Pa)	400Pa	400Pa
Speed Setting	High & Middle & Low	High & Middle & Low
Delay Shutoff	N	N
Oil Filtration Rate	95%	95%
Smell Reduction Rate	98%	98%
Color	Onyx Black	Silver Grey
Operation	Push Buttons	Push Buttons
Capture Shield	Fixed Open	Fixed Open
Screen Lock	N	N
Oil Filter	Removable & Dishwasher Free	Removable & Dishwasher Free
Oil Cup	One Large Oil Cup	One Large Oil Cup
Installation	Wall-Mount/Under-Cabinet	Wall-Mount/Under-Cabinet

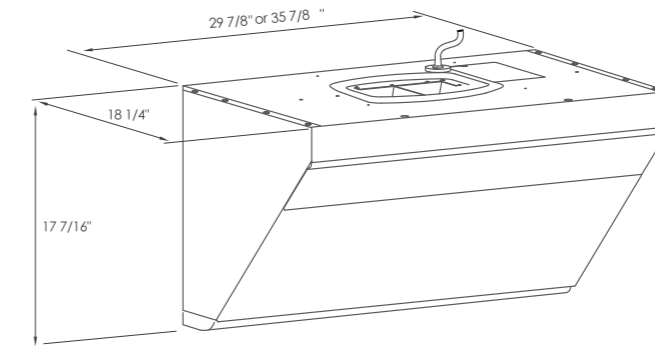

▲ Product Dimensions

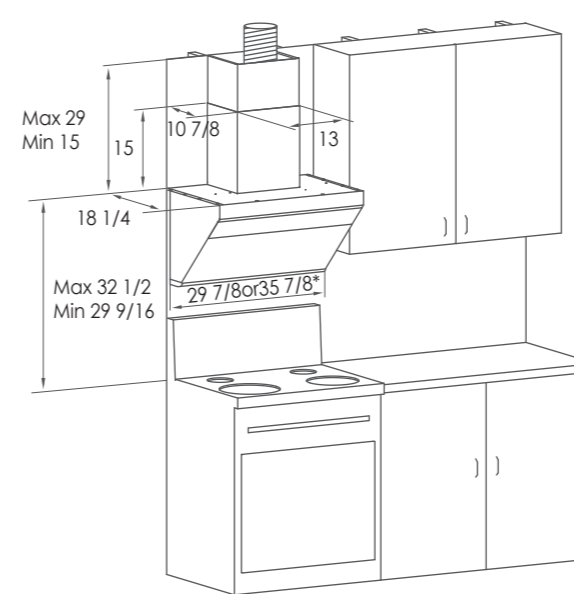

▲ Without upper cabinet+decorative cover

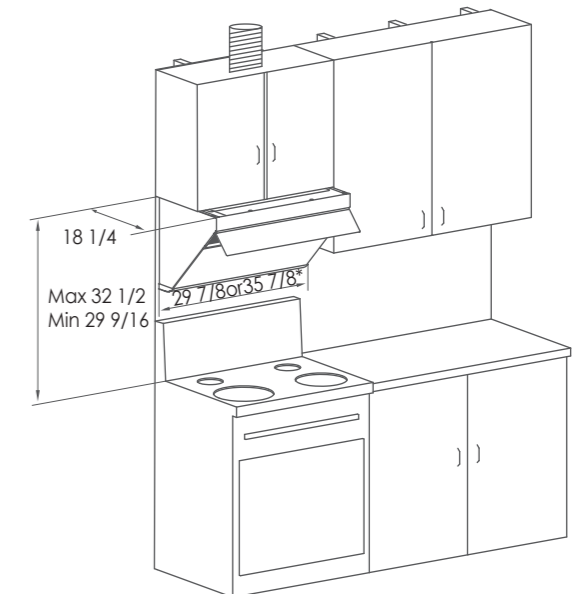

▲ With upper cabinet

* Product Width: 29 7/8 inch = JQG7501/JQG7501.G/JQG7502/JQG7502.G/JQG7505
Product Width: 35 7/8 inch = JQG9001

us.fotileglobal.com

FOTILE

Perimeter Vent Series

A BREATH OF FRESH ENGINEERING®



Model: *EMS9018*



Model: *EMG9030*



Member of HVI, the most authoritative and credible institution in North America



product design award

FOTILE's Perimeter Vent Series features auto-turbo mode that allows the range hood to intelligently adjust the operation to cope with the extraction environment. The innovative Capture Shield Technology provides powerful extraction more evenly. Adapting a three-step purification technique, FOTILE Perimeter Vent Series can achieve a 98% odor reduction from surrounding air and a 92% separation of grease and fumes.



Smart Smoke Detection

For fast, thorough extraction, your FOTILE range hood's Intelligent Capture Shield automatically adjusts its elevation, lowering between 3.2-4.7 inches, based on the volume of smoke, grease, and vapor detected. Smoke has virtually no chance of escaping!

3.2 in / Quiet, Low-Speed Extraction Ideal For Light Frying

Even the simplest recipes sometimes produce smoke and other unpleasant odors. FOTILE's Intelligent self adjusting Capture Shield keeps your kitchen clean and fresh by trapping smoke vapors and removing them. Using smart sensors, the Capture Shield automatically sets fan speed accordingly while lowering the Capture Shield height by 3.2 inches for quick, effortless ventilation.



Sleek, Modern Design

When turned OFF, the self adjusting Capture Shield and the inner smoke chamber are automatically tucked inside the unit's flat configuration, creating an elegant, modern design.



4.7 in / Heavy-Duty Extraction Ideal For Heavy Smoke And Grease

Cooking with high-heat, stir-frying, and deep frying are all great examples of cooking styles that can quickly cause a kitchen to fill up with smoke. Thankfully, FOTILE Perimeter Vent Series Range Hoods are designed to respond to high amounts of smoke by increasing the fan speed and dropping the Capture Shield by 4.7 inches to proactively remove smoke and other harmful odors.

* Adjustable Capture Shield available on EMG9030 only

FOTILE's Innovative, High-Powered DC Inverter Motor

Discover quiet, yet powerful smoke extraction for a peaceful cooking experience.

Astounding 100,000 RPH

Completing 100,000 rounds per hour, the direct-current inverter in your FOTILE Perimeter Vent Series Range Hood ensures smoke and other unpleasant odors are extracted as quickly and thoroughly as possible.

(DC motor is available on EMG9003 only)

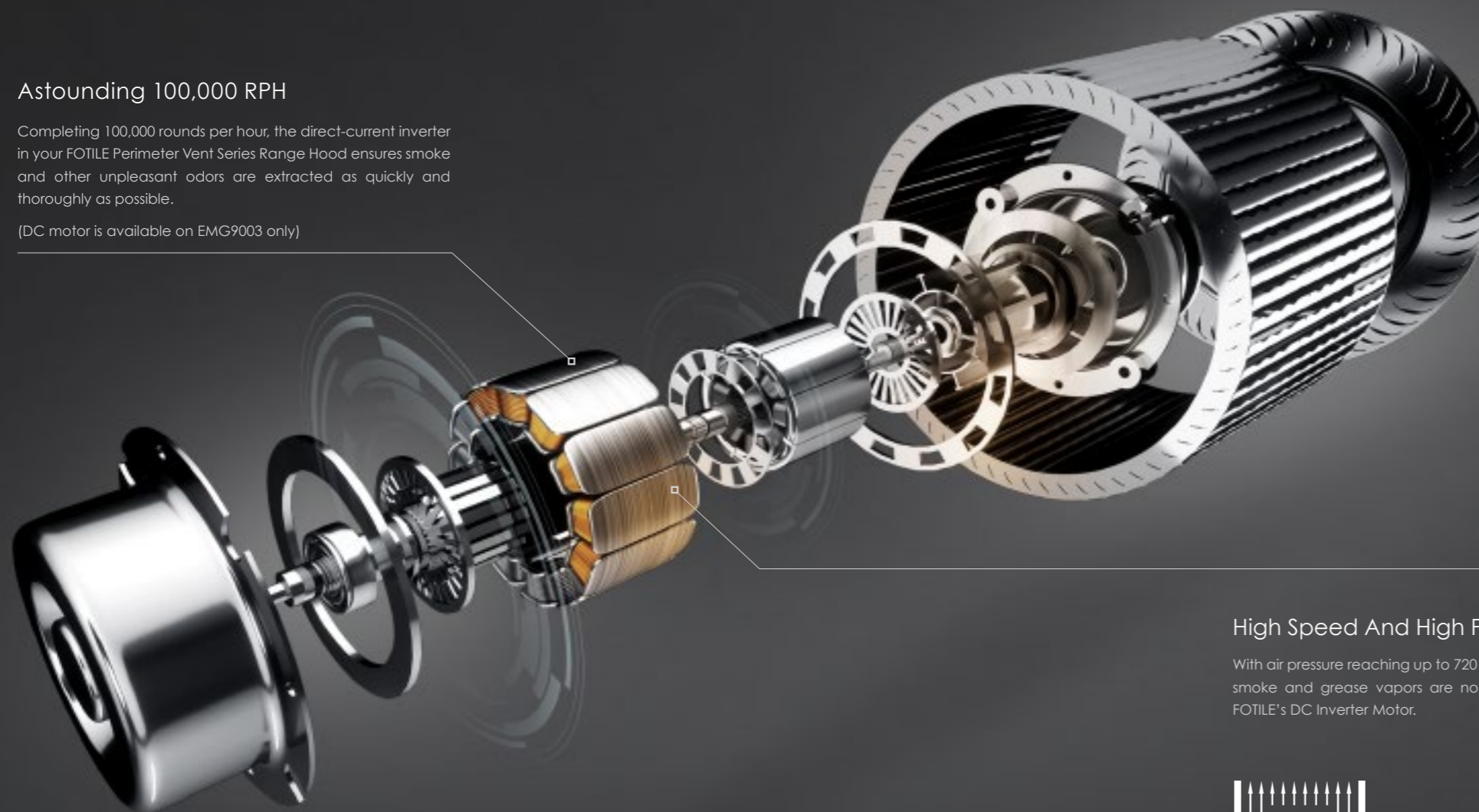

High Speed And High Pressure

With air pressure reaching up to 720 Pa, kitchen smoke and grease vapors are no match for FOTILE's DC Inverter Motor.



FOTILE Perimeter Vent Series **720 Pa**
Traditional Chimney Range Hoods **420 Pa**



Smart Smoke Detection. Intelligent Suction. No More Stray Smoke.

FOTILE Perimeter Vent Series range hoods offer intelligent functionality to adjust speed and height settings automatically, based on the volume of smoke and odors in your kitchen.

* available on EMG9030 only



Auto Turbo System

If, at any point during the ventilation process, the FOTILE range hood detects resistance, the unit will automatically switch to its most powerful mode for maximum extraction capacity.



Intelligent Air Management Protects Your Home From Dangerous Gases

FOTILE's Intelligent Air Management system is designed to keep your home safe and clean at all times. Enjoy peace of mind knowing your range hood is capable of identifying and extracting the following airborne pollutants: Formaldehyde, Ammonia, Carbon monoxide (CO), Benzene, Cigarette smoke, Residual cooking smoke...and more!

Be sure to turn on the Intelligent Air Management system - even when you're not cooking

us.fotileglobal.com

FOTILE

Perimeter Vent Series



Model	EMG9030	EMS9018
Certification	ETL,HVI	ETL,HVI
Product Dimensions (inch)	35 7/16(W) * 20 5/16(D) * 27-38 5/8(H)	35 7/16(W) * 20 5/16(D) * 27-38 5/8(H)
Max. EQUIV. CFM	1100	900
Power Supply	120V/60HZ	120V/60HZ
Input Power	262W	310W
Motor	DC Motor	AC Motor
Illumination(W)	2W x 2 (LED)	2W (LED)
Noise Level(dB)	40.5-57	44-57
Highest Static Pressure(Pa)	720	400
Speed Setting	Auto/Boost & High & Middle & Low	Turbo/Boost & High & Low
Delay Shutoff	2/5/10min	2min
Oil Filtration Rate	92%	92%
Smell Reduction Rate	98%	98%
Operation	Touchscreen	Touchscreen
Capture Shield	Fixed and Intelligent Self-Adjusting	Fixed
Oil Filter&Oil Cup	Removable & Dishwasher Free	Removable & Dishwasher Free
Intelligent Self-Adjusting	Y	N
Auto Smoke Detection	Y	N
Intelligent Air Management	Y	N
Auto Turbo	Y	Y
Installation	Wall-Mount	Wall-Mount

EMG9030

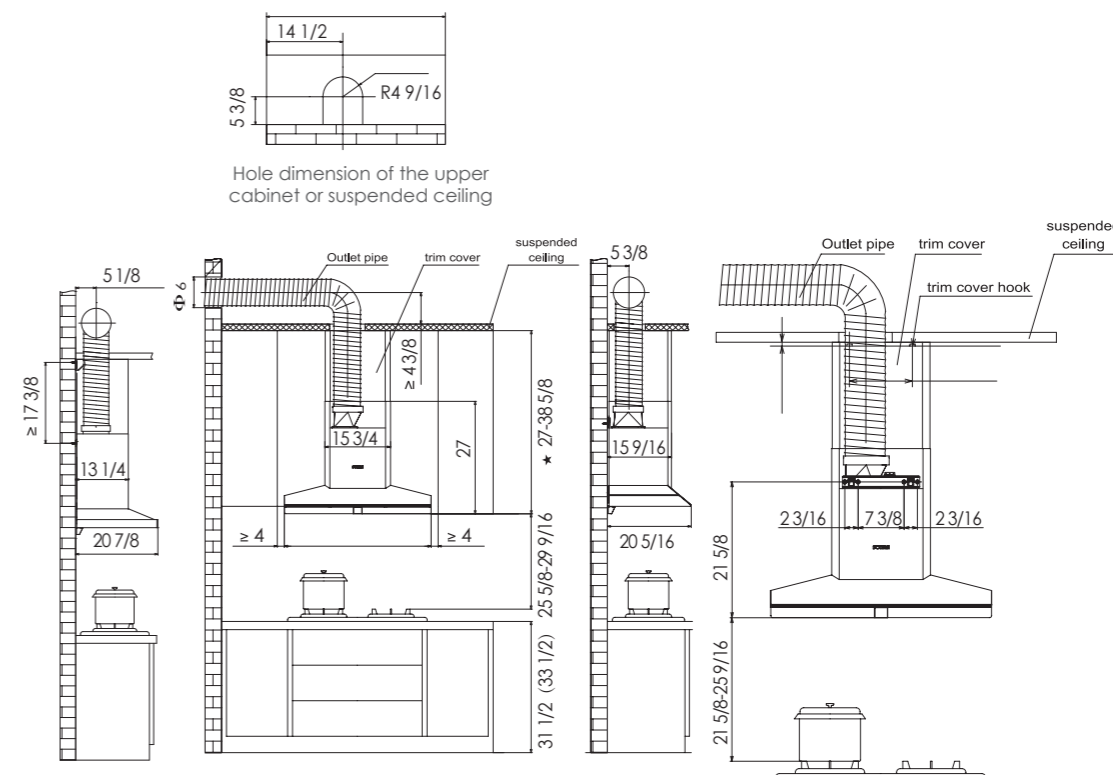

EMS9018

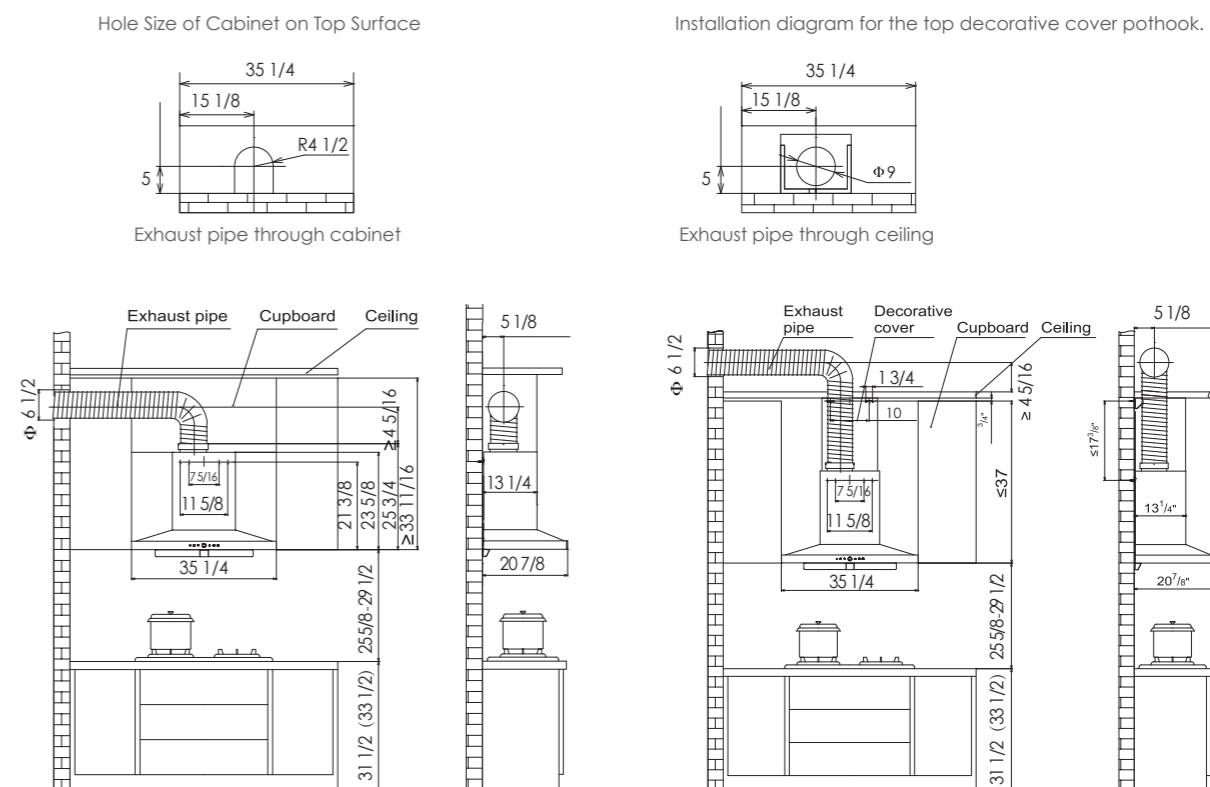

FOTILE

Tri-Ring 5-Burner Gas Cooktop



FOTILE's Tri-Ring gas cooktop is designed for efficient and versatile cooking. A 21,000 BTU center mounted Tri-Ring burner works wonderfully whether you are looking to power boil water, or need high intense heat for sautéing, searing, or stir frying on the included wok grate. A dedicated 3,000 BTU Simmer burner allows for accurate and consistent heat for delicate cuisines, and the two left burners deliver 13,000 BTUs each, offering optional griddle control.

Featuring a Flame Failure Detection System, the safety device in the cooktop will be activated and automatically cut off the gas supply if the flame goes out accidentally.

One Cooktop Meets All Your Cooking Needs

Most burners offering 21,000 BTUs are designed for commercial use and are rare in household appliances.

FOTILE Tri-Ring Cooktop - GLS30501 makes it possible for you to show off masterful cooking skills with household cooktops. The five well-designed burners offer different temperature ranges. Whether you want to cook fish, paella or tacos, Tri-Ring Cooktop can always meet your cooking needs.



Professional Tri-Ring High Output Center Burner

Compared with the double-ring burner, the professional tri-ring burner not only delivers higher heat, but also can heat up the bottom of pots and pans more evenly.

Whether stewing or frying, high or low fire, the tri-ring burner can heat up the food evenly and help you avoid the dilemma of uneven cooked food. You can adjust the three flame rings synchronously by rotating the knob clockwise, and increase or decrease the number of flame rings by rotating the knob counterclockwise. Flexible heat control helps you deliver outstanding cooking results.

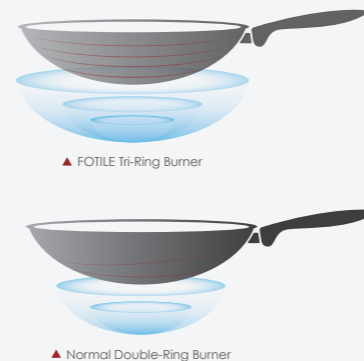

21000BTU high heat + wok grates

Whether you want to make a Chinese-style stir fry, or sear a steak in a hot pan, the Tri-Ring Cooktop can help you deliver outstanding results.



Dedicated simmer burner

Looking to put a soup on simmer, or heating up delicate sauces so they stay hot, but do not burn? The FOTILE Tri-Ring Cooktop has a dedicated Simmer burner capable of 3,000 BTUs. This low power burner is ideal for simmering or heating delicate sauces with accurate consistent low temperature so they will not burn.



Two burners with the same specifications designed to perfectly accommodate a griddle

When cooking food like a whole fish or fillet of steak, a rectangular griddle pan can come in handy. The two left burners of the Tri-Ring cooktop have the same specifications, delivering 13,000 BTUs each. They also accommodate an optional griddle with a pre-set griddle temperature setting on the control knob.



Copper Burner Cap

Copper Burner Head

Copper Burners

Both burner heads and burner caps are made of pure copper, which has better thermal conductivity than aluminum-alloy cast iron.

Burners made of pure copper are not only outstanding in appearance, but also not easy to deform under high temperature, and therefore are much more durable.

us.fotileglobal.com

A Cooktop that Gives You the Peace of Mind



Flame Failure Protection

Are you worrying about gas leakage if the burner flames go out accidentally? The Flame Failure Device will automatically cut off the gas supply in case the flame goes out.



Smooth Slim-Line Surface Finish

The cooktop features a super slim design with round edges for a premium look and feel.



Insulated Materials for Added Safety

The core material of our cooktop knobs are made from insulated material and will never exceed 104 degrees even when you are cooking with high heat. In addition, they are also insulated from electrical shock in case you were to leak any liquids into your cooktop. This insulated material is for your added safety.



Well Thought Out in Every Detail

Easy To Clean

The Tri-Ring Cooktop is super easy to keep clean. All the edges of the cooktop panel are rounded so no food or debris can get trapped underneath and easily be removed. All the cooking knobs, burners, and grates are fully removable for easy cleaning with a damp towel and mild dish soap.

Fast Ignition

The Tri-Ring Cooktop adopts independent fast ignition systems for each burner. Just press, turn, and release the knob and the burner will light immediately.

Edge to Edge Grates

We use Cast Iron cooking grates that run from edge to edge on the cooktop. This means, you will always have space to put small and large pots and pans no matter what size or shape they are. It also allows you to move a hot heavy pot easily and safely from one burner to another if you need to.

Continuous edge to edge cooking grates makes it easier to cook on your cooktop's surface. Simply slide your heavy pots and pans to a different burner without picking them up. Cast Iron grates also offer long lasting performance.



Sophisticated craftsmanship

With a clean look, the cooktop can fit seamlessly into kitchen countertops.



Compatible with many types of pots and pans

Works with all sizes of pots and pans.



Childproof lock

The burner will be ignited when the knob is pressed to the maximum position. The lock is designed to prevent children from turning on the cooktop accidentally.

FOTILE Tri-Ring Cooktop



Model	GLS30501
Certification	ETL
No. of Burners	5
Product Dimensions (W×D×H)(inch)	30 × 21 × 5 1/4
Cut-Out Dimensions (W×D×H)(inch)	28 1/2 x 19 5/8 x 3 1/8
Panel Material	Stainless Steel
Gas Supply	Natural gas, LPG (Conversion kit included)
Power Supply	120V/60Hz
Heating Load (Natural Gas)	Center: 21,000BTU
	LF/LR: 13,000BTUx2
	RF: 6,000BTU
	RR: 3,000BTU
	Total: 56,000BTU
Grate	Cast Iron cooking grates and wok ring attachment included
Fast Ignition	√
Flame Failure Device	√

Installation Information:

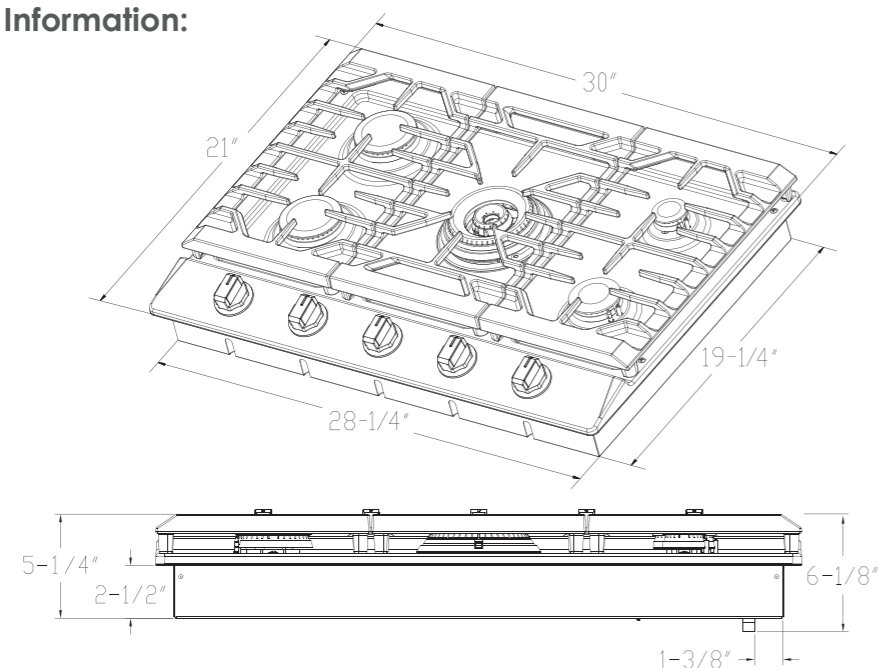

Installing The Cooktop:

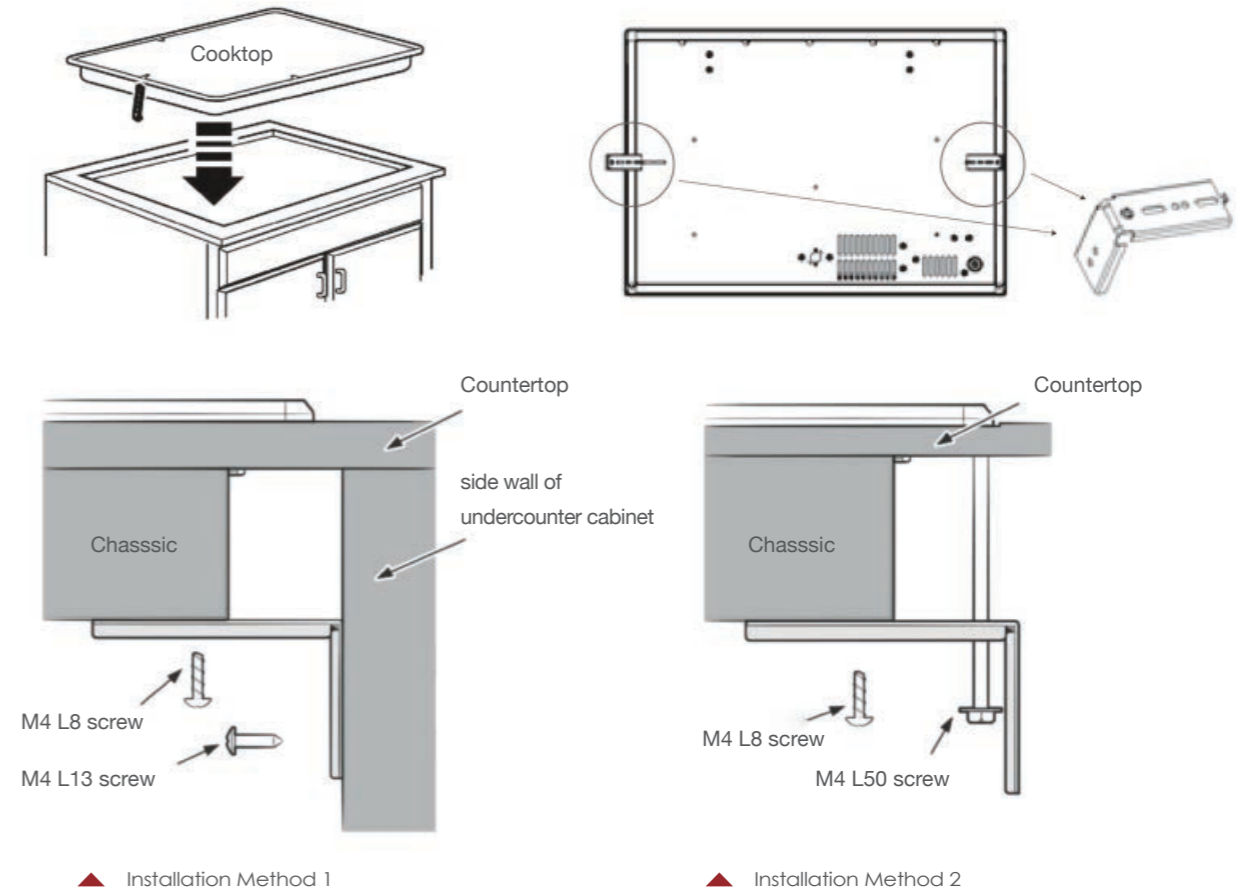

Choose installation method 1 or method 2 shown above to secure the cooktop to the countertop using the two provided hold-down brackets as shown.

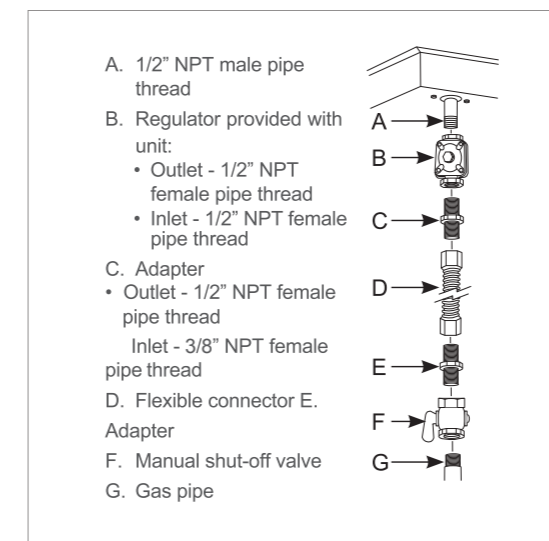

▲ No appliance/obstructions below cooktop

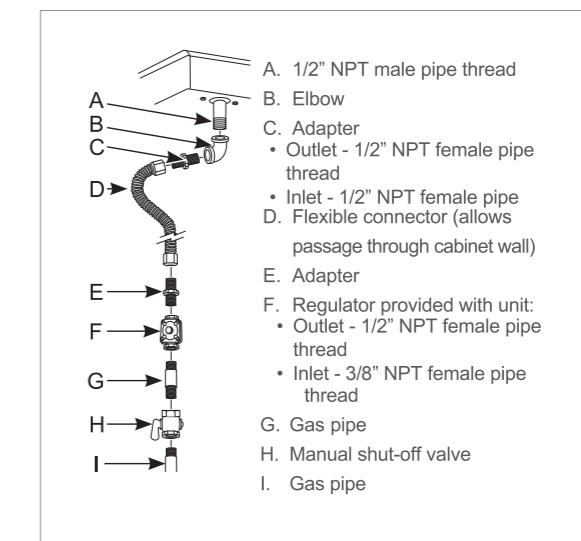

▲ Suggested installation to avoid interference below cooktop

EPS | EFFICIENT

Step 3 | Efficient Combustion

Utilizing larger size flame ports around the burner and oxygen flame cap, this ensures the proper level of air intake through the inlets, maximizing the cooktop's efficiency.



Step 2 | Large Premix Compartment

Acts as a gas reservoir, letting in oxygen to combine with the fuel, and then releasing the mixture in a steady, unbroken stream.



Step 1 | Jet Collision Technology

Initiates a high-speed collision of gas and oxygen within the extended chamber, ensuring thorough mixing for a steady flame.

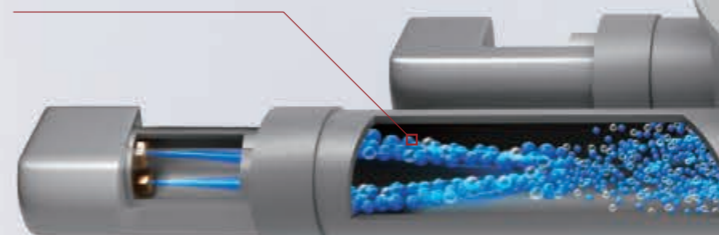
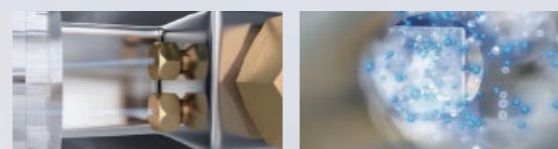

us.fotileglobal.com



FOTILE EPS Series Cooktop

Maximizing Efficiency, Power, and Safety, FOTILE's EPS combines everything you are looking for in a cooktop. Featuring a 12-step safety protection system, FOTILE's EPS cooktops help to prevent fire hazards and harmful gas Leaks from adversely affecting your family's health. The heating efficiencies of our EPS cooktops are about 50% higher than average, making this series an economical choice. Available in stainless steel and black tempered glass, you can always find the unit that suits your kitchen.

EPS | POWERFUL

The perfect burner can meet all types of cooking demands. Your FOTILE burner is suitable for any style of cooking, from stewing to deep-frying, and everything in-between.



Oversized burner ports

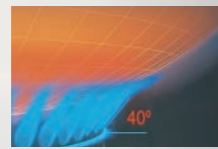

40° flame angle

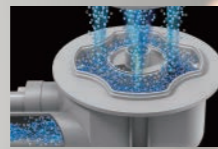

large pre-mix compartment



U5-nozzle injector



Double stabilize flame ring



Jet collision technology

EPS | SAFE

12 built-in safety features for added reliability to ensure the durability and safety of our product.



Integrated silicon aluminum and alloy burner



Anti-flashback shield



Child proof knob



Separation box for gas & electricity



3X reinforced gas leak prevention seal



Copper tubing



Ignition pin protection cover



High-end anti-explosion panel

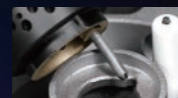

Installation guide positioning pin



Flame failure device



Waterproof cover



Electrical wire wrap shield

A BREATH OF FRESH ENGINEERING®

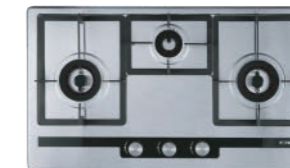

Model	GAG86309	GAS78307	GAG76202
Certification	ETL	ETL	ETL
Product Dimensions(WxD)(inch)	33 7/8 x 19 11/16	30 3/4 x 17 3/4	29 15/16 x 17 9/16
Cut-Out Dimensions(WxD)(inch)	32 3/16 x 18 1/8	27 7/8 x 15 5/16	27 7/8 x 15 5/16
Power Supply	Battery	Battery	Battery
No. of Burners	3	3	2
Panel Material	Tempered Glass	Stainless Steel	Tempered Glass
Grate	Cast Iron	Cast Iron	Cast Iron
Heating Load(BTU)	L: 14800 M: 5800 R: 14800	L: 14800 M: 5800 R: 14800	L: 14800 R: 14800
Heating Efficiency	≥60%	≥60%	≥60%
	Efficient Heating Load nearly 9000BTU, 10% higher than normal products		
Fast Ignition	√	√	√
Net Weight(lbs)	39.7	26.9	24.3
Gross Weight(lbs)	44.1	31.7	28.6
Packing-Box Size (WxDxH)(inch)	35 7/8 x 21 1/2 x 8 5/16	34 1/2 x 20 1/2 x 8 1/2	32 5/16 x 20 5/8 x 8 3/4

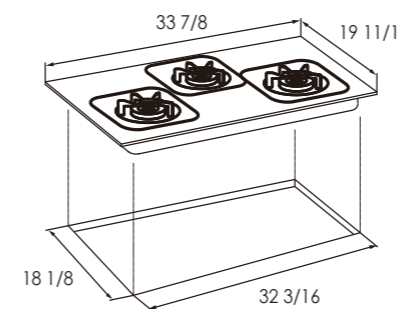

GAG86309

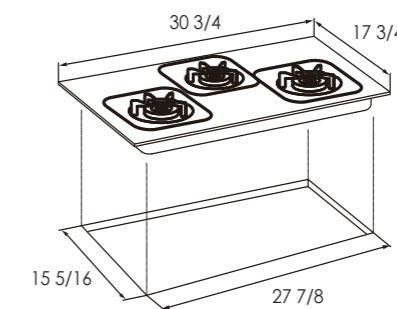

GAS78307

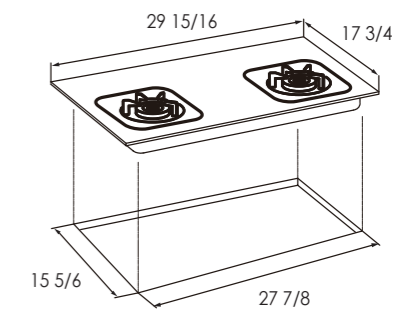

GAG76202

us.fotileglobal.com

FOTILE

3-IN-1 In-Sink Dishwasher



FOTILE's In-Sink Dishwasher is designed for modern living in compact spaces.

It is a sink, a dishwasher, and a produce & seafood cleaner all in one product. It manages to address more kitchen problems with less space and energy consumption. The counter-top mounted design eliminates bending over to load and take out dishes like you would with traditional under the counter appliances, making it suitable for a broader demographic.



Enjoy the delicacy

Brunch for one, wine for two, afternoon tea for three, or lasagna for four ... leave everything else to FOTILE.

Simple Ways to Get Rid of Bacteria Stay Safe and Healthy

If food residues are left for 10 hours at room temperature, the number of staphylococcus and E. coli may increase up to 70,000 times the original amount. A small piece of cloth may host up to 19 types of bacteria and fungus. The FOTILE 3-IN-1 in-Sink Dishwasher eliminates harmful bacteria through high temperature washes and a pasteurization drying process, creating healthy clean dishes for your family.

FOTILE's innovative 3-IN-1 In-Sink dishwasher

Delicate Wash **20min** Standard Wash **45min** Intensive Wash **80min**

Precise water volume from the Rotary Spraying arms enables 360° water shield technology blanketing all the contents inside with a complete hot wash at 158°F. The result is, ultra-clean dishes with no blind spots!

us.fotileglobal.com

Fruit, Vegetables ... and Seafood

Delicate Strawberries, Fresh Broccoli, and Tasty Crabs.
Your fruit, vegetables and seafood can be washed and cleaned in the FOTILE 3-IN-1 In-Sink Dishwasher.

FOTILE Uses Patented Technologies

including Ultrasonic Turbulence for the produce cleaning.
The produce and seafood cleaner can remove dirt and over 90% of harmful pesticides. FOTILE's 3-IN-1 In-Sink Dishwasher is environmentally friendly by eliminating secondary contamination from chemicals in detergent.



Your food must be treated in the healthiest way!

More Possibilities

Home Bars, Home Cafes, Tiny Houses, RVs.....
Installation can be done at places that were once impossible!



FOTILE combines technology with practicality to elevate consumers' lifestyles.

Explore more possibilities with FOTILE.

us.fotileglobal.com

FOTILE In-Sink Dishwasher



Washing Mode and Features

Washing Mode	Dish Washing			Produce Washing		
	Delicate	Normal	Intensive	Delicate	Normal	Intensive
Highest Washing Temperature (°F)	122	158	158	Room Temperature		
Washing Time (min)	20	45	80	8	13	18
Water Consumption(gal/cycle)	1.85	2.4	3.17	Low: 2.91	Low: 3.43	Low: 3.96
				Med: 3.96	Med: 4.49	Med: 5.02
				High: 5.02	High: 5.55	High: 6.08
Number of Wash Steps	3	5	5	1	2	3
Rack Adjustability	Yes			/		
Fan Assisted Drying	Yes			/		
Concealed Heating Plate	Yes			/		
Tube Material	Stainless Steel					
Operation	Touchscreen					
Digital Display	Yes					
Audible Alerts	Yes - End of Wash					
Leak Protection	Yes					
Child Lock	Yes					

Model	SD2F-P1X * Sink strainer & faucet are not included
Wattage(W)	2150
Current (A)	9
Volts (V)	240
Frequency (Hz)	60
Recommended Water Pressure (psi)	20.3 - 145.04
Noise Level (dB)	56.6-62.1
Length of Electrical Wire (ft)	4
Product Dimensions (LxWxH)(in)	39 x 19 5/16 x 22
Height of the Dishwasher Door When Fully Open(in)	16 3/8
Cut-Out Dimensions (LxWxH)(in)	19 5/8 x 14 7/8 x 8 5/8
Cutout Demensions (LxWxH) (in)	38 x 18 1/8 x ≥ 25

Accessories	
Dishwasher Basket	1-INCLUDED
Produce Basket	1-INCLUDED
Secondary Sink Kit	OPTIONAL
Faucet	NOT INCLUDED

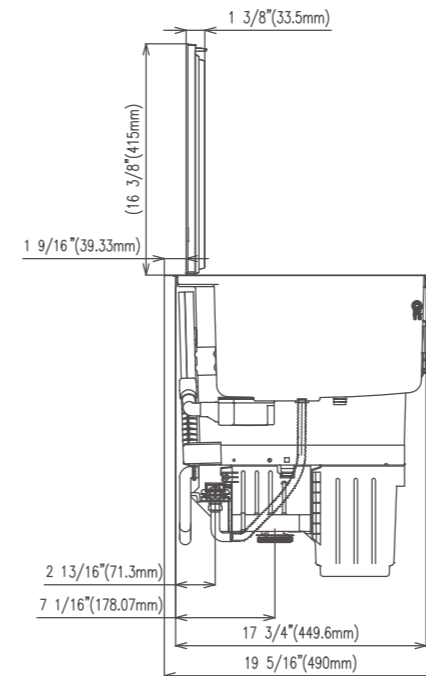

▲ Side

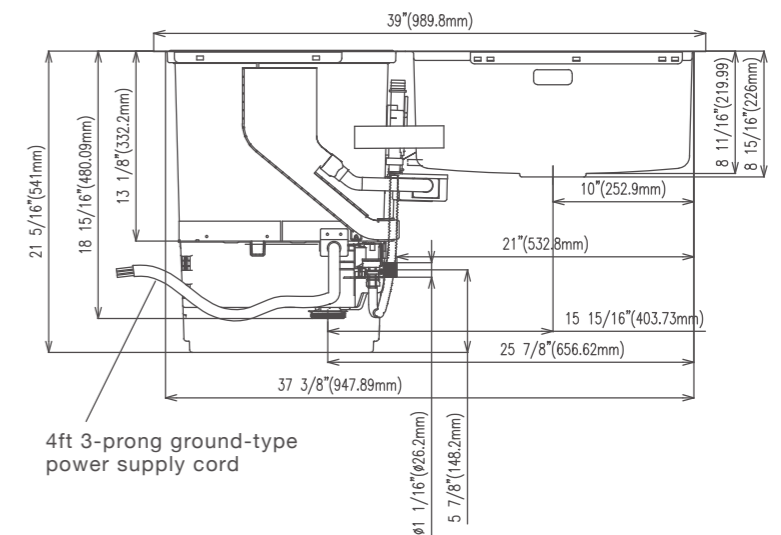

▲ Back

KSG7003A / CONVECTION OVEN

KSS7002A / CONVECTION OVEN



Features

2.47 cu.ft. provides plenty of space for all your baking needs

Elegant tempered glass and large low-E glass window

Hot air filter design allows for a more stable and even temperature.

10 preset cooking modes for easy use and maximum efficiency

Damping hinge for soft closing door.

Rated for high energy efficiency

Features

2.47 cu.ft. provides plenty of space for all your baking needs

Elegant stainless steel and large low-E glass window

Hot air filter design allows for a more stable and even temperature.

10 preset cooking modes for easy use and maximum efficiency

Damping hinge for soft closing door.

Rated for high energy efficiency

Specification

Certification	ETL	Certification	ETL
Product Dimensions (WxHxD)(inch)	23 7/16 x 23 7/16 x 21 3/4	Product Dimensions (WxHxD)(inch)	23 7/16 x 23 7/16 x 21 3/4
Build-in Dimensions (WxHxD)(inch)	Flush Built-in 23 9/16 x 23 9/16 x (≥22 7/8) Standard Built-in 22 1/16 x 23 1/4 x (≥21 11/16)	Build-in Dimensions (WxHxD)(inch)	Flush Built-in 23 9/16 x 23 9/16 x (≥22 7/8) Standard Built-in 22 1/16 x 23 1/4 x (≥21 11/16)
Capacity (cu.ft.)	2.47	Capacity	2.47
Power Supply	220-240V/60Hz	Power Supply	220-240V/60Hz



FOTILE Master Series Convection Oven



10 Preset Cooking Modes for Ease of Use

Baking, Grilling, Proofing, Defrosting & Much More



Uniform Temperature for Accurate Cooking

Five Heating Tubes
3D-Hot-Air Circulation System
Platinum-Alloy Temperature Sensor.



Professional Grade Glass Door

2 Layers of Low-E Glass
1 Layer of Tempered Glass



SCD42-C2T / STEAM OVEN

SCD42-F1 / STEAM OVEN



Features

- Innovative dynamic steam-balance technology
- 8 preset modes
- Precise temperature control system
- Elegant O-Touch design and simple to clean

Features

- Innovative dynamic steam-balance technology
- 6 preset modes
- Precise temperature control system
- Elegant stainless steel series

FOTILE Steam Ovens



Innovative Dynamic Steam-Balance Technology

The perfect amount of fresh steam at a precise temperature, providing delicious taste.



One Touch Cooking

Multifunctional preset options including Meat, Fish, Vegetable, Pasta, Defrost, Self-clean, and much more for easy and effortless operation.



Easy to Clean

Food Grade 304 Stainless Steel is easy to clean with a damp cloth. Detachable oven racks are dishwasher safe.

Specification

Certification	ETL
Product Dimensions (WxHxD)(inch)	23 7/16 x 17 15/16 x 20 1/4
Build-in Dimensions (WxHxD)(inch)	Flush Built-in 23 9/16 x 18 1/8 x (≥21 11/16)
	Standard Built-in 22 1/16 x 17 3/4 x (≥21 11/16)
Wattage (W)	2400
Power Supply	240V/60Hz
Capacity (cu.ft.)	1.48
Temperature Range (°F)	86-212
Preset Modes	8
Material	Tempered Glass

Specification

Certification	ETL
Product Dimensions (WxHxD)(inch)	23 7/16 x 17 15/16 x 20 1/4
Build-in Dimensions (WxHxD)(inch)	Flush Built-in 23 9/16 x 18 1/8 x (≥21 11/16)
	Standard Built-in 22 1/16 x 17 3/4 x (≥21 11/16)
Wattage	2400
Power Supply	240V/60Hz
Capacity	1.48
Temperature Range (°F)	86-212
Cooking Modes	6
Material	Stainless Steel and Tempered Glass

KSG7003A/KSS7002A / Convection Ovens

Flush Built-in

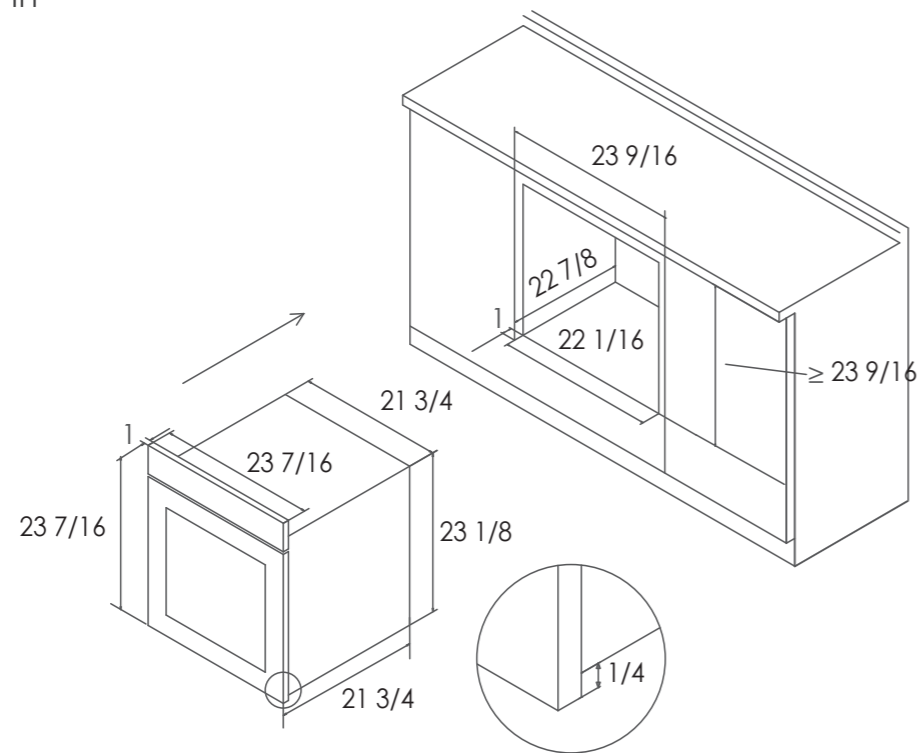

Standard Built-in

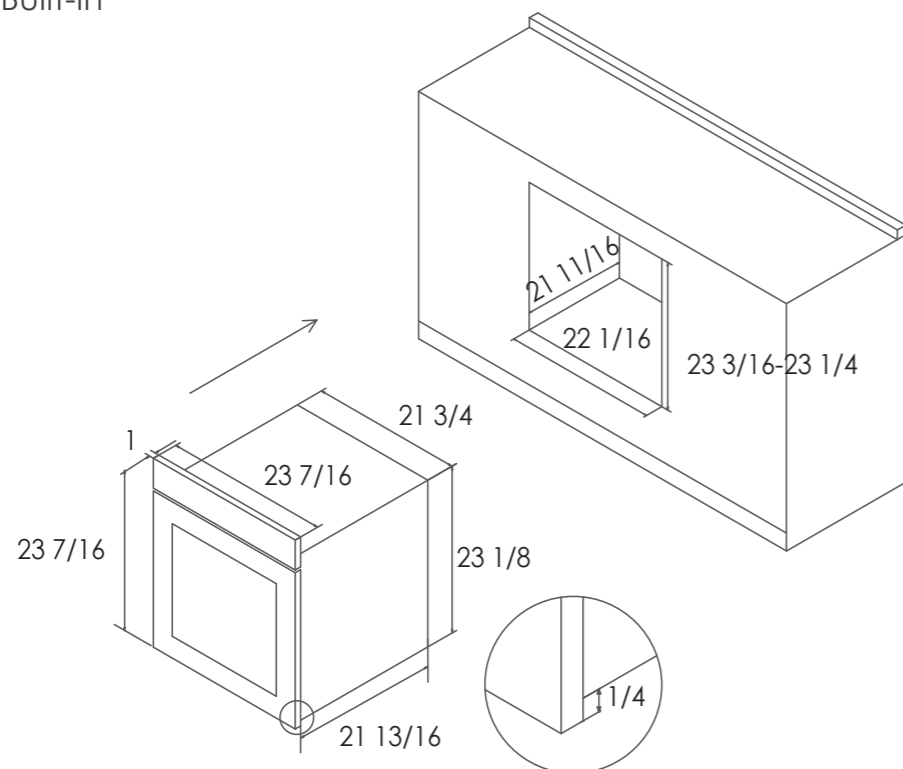

SCD42-C2T/SCD42-F1 / Steam Ovens

Flush Built-in

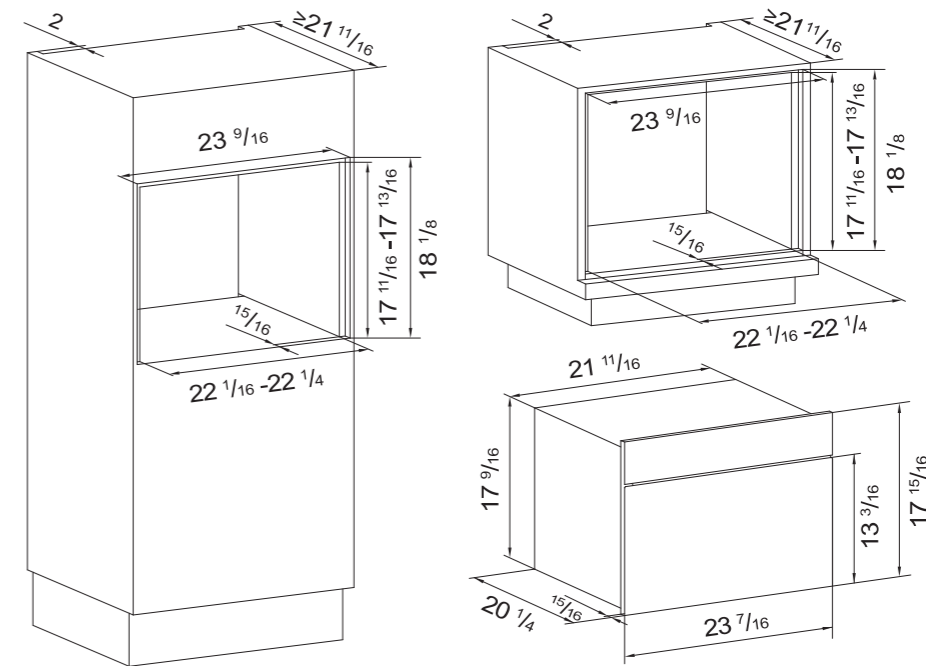

Standard Built-in

