

ARTEC INDUSTRIES JL LICENSE PLATE MOUNT

Thank you for your purchase of our JL License Plate Mount . If you have any questions that are not answered in these instructions, please feel free to contact us directly at sales@artecindustries.com or 855-278-3299 and we will be happy to help you.

Bill Of Materials

ITEM NO.	PART NUMBER	DESCRIPTION	QTY.
1	JL5620-3	JL License Plate Lug Nut	2
2	JL5620-LASER	JL License Plate Bracket - LASER CUT COMPONENTS	1
3	HW0092	1/4"-20 x 1/2 Button Head Socket Cap Screw Zinc Plated	6
4	HW0100	M14 x 1.5 mm Grade 8.8 Hex Bolt ZINC PLATED	2
5	HW0053	9/16 in F436 SAE (Type A Narrow) Flat Washer Yellow Zinc	2



REQUIRED TOOLS

- 5/32 Allen
- 22MM Hex
- Wiring Tools (Plate Light)

STEP 1. Unpack contents of shipment. Make sure that all of the parts required are included with your kit. If any items are missing, and packaging is damaged, report it to the shipping company driver, KEEP ALL ORIGINAL PACKAGING & contact us.

STEP 2. First start by parking the vehicle on level ground and applying the parking brake. Start by removing the top two lug nuts holding the spare tire onto the vehicle. Install the included speciality lug nuts and torque to 80 FT/LBS. Next assemble the license plate brackets prior to installing on the vehicle. Use the provided hardware to fasten your license plate onto the mount.

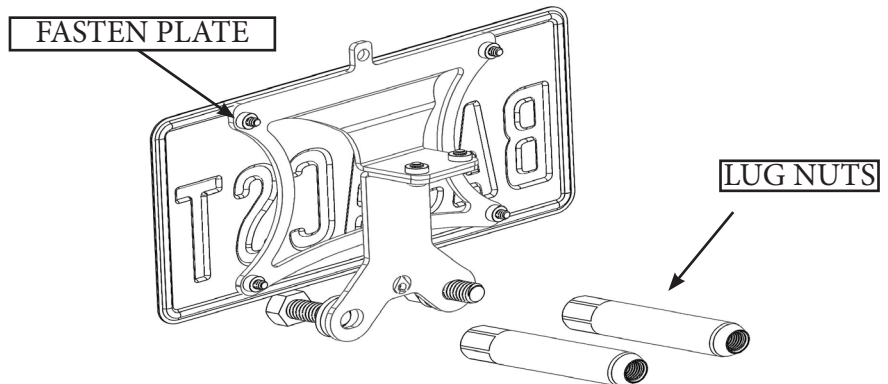

STEP 3. Install the complete assembly using the provided metric bolts. The bolts and specialty lug nuts are intentionally designed to use your factory lug nut wrench. Tighten bolts to 40 FT/LBS. If your license plate is contacting your wheel you can adjust it out by loosening the two bolts holding the brackets together. If you need even more spacing you can flip the bottom bracket to gain more room. To finish the install wire in our optional license plate mount or aftermarket light of your choice.

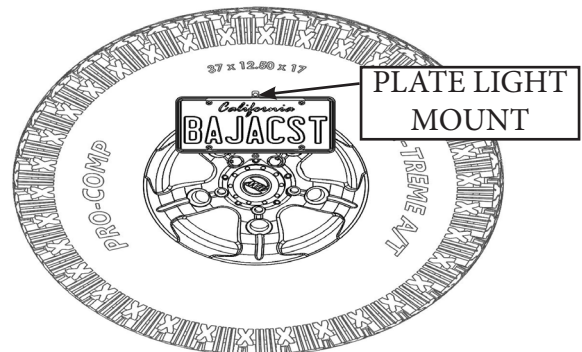

NOTE: THIS KIT INVOLVES VEHICLE MODIFICATION AND MECHANICAL SKILLS. IF YOU ARE NOT CONFIDENT IN YOUR SKILLS, CONTACT A PROFESSIONAL INSTALLER.