

1101 DFB Laser with TEC

DFB-15XXH-PM-YY

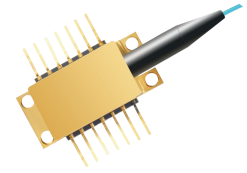

DFB Laser, 1550 nm, Up to 40 mW, PM Output, DM Capable

The Optilab DFB-1550H-PM is a single frequency laser coupled with Polarization Maintaining fiber. Built with Distributed Feed-Back Grating (DFB) as cavity reflector, it provides pure, single longitudinal mode, hopping free and extremely stable wavelength source. This laser diode is fabricated with Multiple Quantum Well (MQW) for excellent reliability and stability. It can be used either in CW operation for seeding the external modulation and coherence interferometry, or directly modulated for signal transmission. This MQW DFB laser features 40 mW of output optical power, high Side Mode Suppression Ratio (SMSR). The standard 14-pin butterfly integrates TEC, thermistor, monitor PD and an output isolator.

FEATURES

- Up to 40 mW Output Power
- Low RIN Noise, -145 dB/Hz max.
- Polarization Maintained Fiber Output
- Wavelengths Range to Select: 1549 nm to 1553 nm
- Built in TEC, Thermistor & Monitor PD

USE IN

- Dense Wavelength Division Multiplex (DWH)
- RF over Fiber (RFoF)
- Hybrid Fiber-Coaxial (HFC)
- General Laboratory and Research Use
- Direct Modulation

FUNCTIONAL DIAGRAM

Pin#	Desc	Pin#	Desc
1	Thermistor	8	Case Ground
2	Thermistor	9	Case Ground
3	LD- (Bias)	10	NC
4	PD+	11	LD+
5	PD-	12	LD RF -
6	TEC+	13	LD+
7	TEC-	14	NC

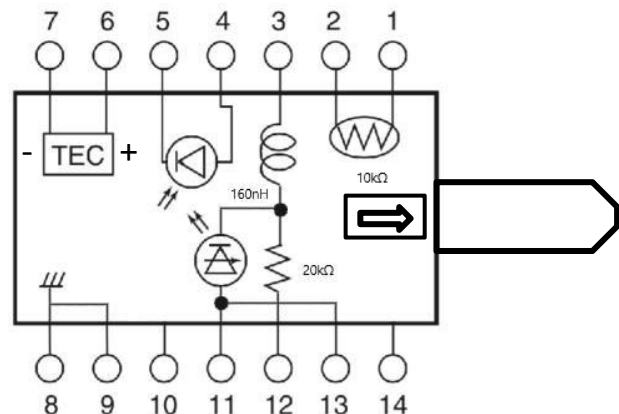

Order notes to our customers: The default parameters are as follows. For special needs, please contact sales.

- 1) Connector FC/APC, 900 um, 1 m by default for all devices except for high power devices.
- 2) Slow axis working, fast axis blocked, connector key is aligned to slow axis by default for PM devices.

1101 DFB Laser with TEC

DFB-15XXH-PM-YY

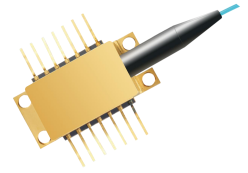

Wavelength Range	1549 nm to 1553 nm
Wavelength Accuracy	±2 nm
Wavelength Tuning	±1.5 nm
Optical Output Power	Up to 40 mW
Operating Current	650 mA
Forward Voltage	2.5 V typ.
Series Resistance	25 Ω typ.
Threshold Current	25 mA typ.
Monitor Current	0.10 mA min.; 1.0 mA max.
Photodiode Dark Current	2 nA typ.; 100 nA max.
Side Mode Suppression	40 dB min.
Linewidth	3 MHz max
Optical Isolation	35 dB typ.
Relative Intensity Noise	-160 dB/Hz max.
Polarization Extinction Ratio	20 dB typ.
Operating Temperature	-10 °C to +60 °C
Storage Temperature	-40 °C to +70 °C
Operating Humidity	95% @ < 30 °C
Optical Fiber Type	PM Fiber
Optical Connector	FC/APC, Other Available
TEC Current	1.0 A max.
TEC Voltage	2.4 V max.
TEC Resistance	2.4 Ω typ.
Thermistor Resistance	7.7 k Ω min.; 12.6 k Ω max.
Thermistor B Constant	3,270 K min.; 3,450 K typ.; 3,630 K max.

Order notes to our customers: The default parameters are as follows. For special needs, please contact sales.
1) Connector FC/APC, 900 um, 1 m by default for all devices except for high power devices.
2) Slow axis working, fast axis blocked, connector key is aligned to slow axis by default for PM devices.

1101 DFB Laser with TEC

DFB-15XXH-PM-YY

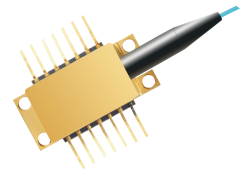

MECHANICAL DRAWING

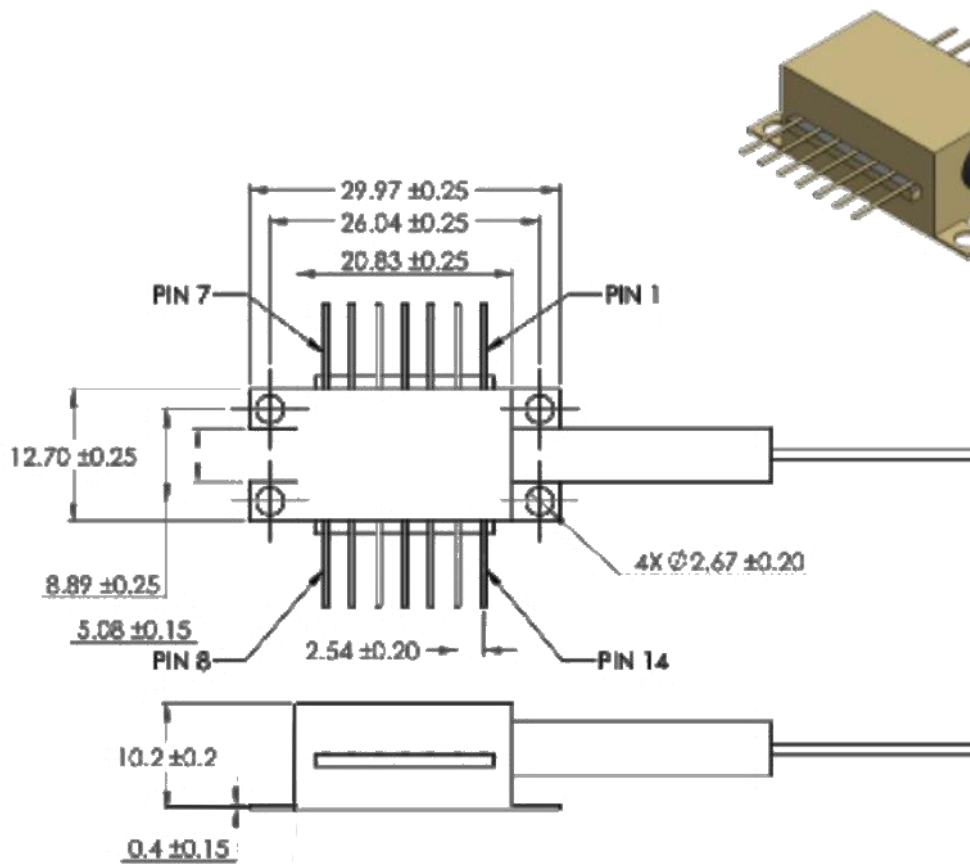

Unit: mm

ORDERING OPTIONS

DFB-15XXH-PM-YY

XX: Wavelength in Nanometer

49 nm, 50 nm, 51 nm, 52 nm, 53 nm

YY: Optical Power in mW

020 mW, 030 mW, 040 mW

Order notes to our customers: The default parameters are as follows. For special needs, please contact sales.

1) Connector FC/APC, 900 um, 1 m by default for all devices except for high power devices.

2) Slow axis working, fast axis blocked, connector key is aligned to slow axis by default for PM devices.